



---

# TUGSAFE CENTRAL

---

Your Online Hub for Subchapter M

OCTOBER 14, 2021

U.S. COAST GUARD  
Towing Vessel National Center of Expertise  
504 Broadway St. Suite 101  
Paducah, KY 42001  
(270) 444-7715

<b>Record of Changes</b>		
<b>Date</b>	<b>Number</b>	<b>Description</b>
12Sep18	1	Updated Manning section and added Determining Manning Levels section
03OCT18	2	Updated Special Consideration section to incorporate guidance per CVC-WI-010
15APR19	3	Added hyperlink to CG-CVC Policy Letter 17-02 (CH-2) Use of Existing Safety Management Systems to Obtain an Initial Certificate of Inspection Under 46 CFR Subchapter M to the Towing Safety Management Systems subparagraph in the TPO and TSMS section.
20JUN19	4	Updated hyperlink to CVC-WI-010(2) OCMI Guidance on Special Consideration for 46 CFR Subchapter M Vessels in the Appeals and Alternate Compliance. Added hyperlink to CG-ENG Policy Letter 01-19 Equivalency Determination – Fire Pumps for Subchapter C and Subchapter M Towing Vessels to the Fire Pumps, Fire Mains, and Fire Hoses subparagraph in the Fire Protection section.
26JUL19	5	Added hyperlink to CVC-WI-03 Towing Vessel COI Inspections under TSMS Option to the Towing Safety Management Systems section.
22JUN2020	6	Updated Oil Pollution Prevention Records/Documents to reflect new PIC/LOD change.
09OCT2020	7	Added hyperlink to CG-CVC Policy Letter 18-04 - Guidance On Implementation Of New Standards For Fire Protection, Detection, and Extinguishing Equipment in the Fire Protection section. Added hyperlink to CG-CVC Policy Letter 19-01 - Enforcement Guidance for Harbor Assist Towing Vessels When Operating Beyond the Boundary Line in the Manning section. Added hyperlinks to CG-CVC Policy Letter 20-01 - Subchapter M Enforcement Posture for Certificate of Inspection Phase-In Requirements, CVC Work Instruction WI 015 - Determinations for a Vessel's Keel Laid Date or Similar Stage of Construction, and CVC Work Instruction WI 018 - Laid up Inspected/Examined Vessels in the Inspection for Certification section.
19FEB2021	8	Added Electronic Certificates topic to the Appeals and Alternate Compliance Options section. Added CG-CVC Policy Letter 19-02 to the Manning topic in the Credentials, Documents and Reports section. Removed the MTSA topic from the Credentials, Documents and Reports section. Added CVC-WI-004 to the International section. Added CVC Work Instruction WI-013 to the Inspection for Certification topic in the Inspections and Surveys for Certification section. Added CVC WI-029 to the Intervals for Drydock, Underwater Survey in Lieu of Drydocking (UWILD) and Internal Structural Examinations (ISE) topic in the Inspections and Surveys for Certification section. Added CG-CVC Policy Letter 17-03 to the TSMS Compliance topic in the Inspections and Surveys for Certification section. Added CVC-WI-011 to the General Requirements for Propulsion, Steering and Related Controls on Vessels that Move Tank Barges Carrying Oil or Hazardous Material in Bulk topic in the Machinery and Electrical section. Added a new Security section with Cybersecurity, MTSA and ISPS topics.
24JUN2021	9	Added Bridge to Bridge inspection and certificate topic to the FCC sub-section under Credentials, Documents and Reports section.
27AUG2021	10	Added link to CG-CVC-PL 21-03 to Intervals for drydock, underwater survey in lieu of drydocking (UWILD) and internal structural examinations (ISE) section in Inspections and Surveys for Certification.

14OCT2021	11	Updated Appeals section in Appeals and Alternate Compliance Options.
-----------	----	--

## Introduction:

Whether you're a CG field inspector, a TPO, or industry, TugSafe Central is your source for Subchapter M compliance requirements and guidance. TugSafe Central combines all TugSafe material and references with applicable Code of Federal Regulations, CVC Policy Letters, Subchapter M FAQs, as well as applicable international requirements (SOLAS and MARPOL) to name a few.

46 CFR subchapter M established safety regulations governing inspection, standards, and safety management systems of towing vessels. This document is a compilation of information to help supplement and provide additional clarification for those requirements. In and of itself, the information contained in this document is not intended, nor adequate, for determining full compliance with 46 CFR Subchapter M and other associated regulations.

Regulations are based on various parameters or breakpoints. As such, some items listed in this document are not applicable to every towing vessel that must comply with Subchapter M. Those utilizing this document should be familiar with, and understand how to determine, regulatory applicability as it relates to individual vessels.

If you would like to generate a custom checklist of requirements for a specific vessel you can do so with the Inspected Towing Vessel Decision Aid (AKA TugSafe). TugSafe is designed to help prepare a towing vessel for inspection and can also be used to inspect a vessel for compliance with Subchapter M.

The TVNCOE strives for continuous improvement and welcomes your feedback (positive and negative) to ensure we meet your needs.

***NOTICE:*** No information herein is intended to supersede or conflict with current laws, regulations, or directives of the United States, U.S. Department of Homeland Security, or the U.S. Coast Guard. If information provided by the "TugSafe Central Your Online Hub for Subchapter M" is inconsistent with law or regulation, then that information is invalid. Please contact the Towing Vessel National Center of expertise, your nearest Coast Guard Towing Vessel Coordinator or Marine Inspector for any questions.

## Table of Contents

<b>Appeals and Alternate Compliance Options</b> .....	1
<b>Alternate Standards</b> .....	1
<b>Alternative Means</b> .....	1
<b>Appeals</b> .....	2
<b>Electronic Certificates</b> .....	3
<b>Equivalents</b> .....	3
<b>Exemptions</b> .....	3
<b>Excepted Vessels</b> .....	3
<b>Special Consideration</b> .....	4
<b>Construction and Arrangement</b> .....	5
<b>Combustibles Insulated From Heated Surfaces</b> .....	5
<b>Crew Spaces</b> .....	5
<b>Design Verification</b> .....	6
<b>Guards in Dangerous Places</b> .....	6
<b>Handrails and Bulwarks</b> .....	7
<b>Lifting Requirements</b> .....	7
<b>Machinery Spaces, Fuel Tank Spaces and Accommodation Spaces</b> .....	7
<b>Markings</b> .....	7
<b>Mattresses</b> .....	8
<b>Means of Escape</b> .....	8
<b>Operating Station Visibility</b> .....	9
<b>Protection Against Hot Piping</b> .....	9
<b>Stability Standards</b> .....	9
<b>Storm Rails</b> .....	10
<b>Structural Standards</b> .....	10
<b>Ventilation</b> .....	10
<b>Waste Receptacles</b> .....	11
<b>Watertight or Weathertight Integrity</b> .....	11
<b>Window or Portlight Strength</b> .....	11

<b>Credentials, Documents and Reports .....</b>	<b>12</b>
<b>Ballast Water Management.....</b>	<b>12</b>
<b>Determining Manning Levels .....</b>	<b>12</b>
<b>Documentation .....</b>	<b>13</b>
<b>Drug and Alcohol Testing.....</b>	<b>14</b>
<b>FCC .....</b>	<b>14</b>
<b>Hazardous Conditions Reporting .....</b>	<b>17</b>
<b>Load Line.....</b>	<b>17</b>
<b>Manning.....</b>	<b>17</b>
<b>Marine Casualty Reporting.....</b>	<b>19</b>
<b>MARPOL ANNEX V .....</b>	<b>19</b>
<b>MARPOL ANNEX VI .....</b>	<b>20</b>
<b>Navigation Publications .....</b>	<b>21</b>
<b>Oil Pollution Prevention Records/Documents .....</b>	<b>21</b>
<b>Records for Towline for Towing Astern.....</b>	<b>22</b>
<b>Registration .....</b>	<b>23</b>
<b>Tests and Inspections.....</b>	<b>23</b>
<b>Fire Protection .....</b>	<b>25</b>
<b>Introduction .....</b>	<b>25</b>
<b>Additional Fire Extinguishing Equipment .....</b>	<b>27</b>
<b>Fire Axe.....</b>	<b>28</b>
<b>Fire-Detecting System .....</b>	<b>28</b>
<b>Firefighter's Outfit.....</b>	<b>29</b>
<b>Fire Hazard Minimized .....</b>	<b>30</b>
<b>Fire Protection Training .....</b>	<b>31</b>
<b>Fire Pumps, Fire Mains, and Fire Hoses.....</b>	<b>31</b>
<b>Hand-Portable Fire Extinguishers .....</b>	<b>33</b>
<b>Heat Detection.....</b>	<b>35</b>
<b>Machinery Space Fire Protection.....</b>	<b>35</b>
<b>Safety Orientation .....</b>	<b>36</b>
<b>Smoke Detection.....</b>	<b>37</b>
<b>SOLAS Chapter II-2 Compliant Vessel .....</b>	<b>37</b>

Storage of Flammables and Combustibles .....	37
International Requirements .....	39
Inspections and Surveys for Certification.....	41
Annual Inspection Fees.....	41
Annual inspections for Coast Guard Inspection Option .....	41
Annual surveys for TSMS External Survey Program .....	41
Annual surveys for TSMS Internal Survey Program.....	42
Approved Equipment .....	42
Certificate of Inspection .....	43
Inspection for Certification.....	43
Intervals for drydock, underwater survey in lieu of drydocking (UWILD) and internal structural examinations (ISE) .....	44
TSMS Compliance.....	45
Lifesaving.....	46
Introduction .....	46
Crew Lifesaving Training Requirements .....	48
Emergency Position Indicating Radio Beacon (EPIRB).....	48
Immersion Suits .....	49
Line Throwing Appliance .....	50
Lifebuoy.....	50
Lifejackets.....	51
SOLAS Chapter III Compliant Vessel.....	53
Survival Craft.....	53
Visual Distress Signals.....	54
Machinery and Electrical.....	56
Alarms and Monitoring.....	56
Bilge Pumps or Other Dewatering Capabilities .....	56
Classed Vessel or Vessel built to Class Rules .....	57
Communication Systems.....	57
Controls and Monitoring .....	57
Electrical Conductors, Connections and Equipment.....	58
Electrical Distribution Panels and Switchboards.....	58

<b>Electrical Grounding and Ground Detection .....</b>	<b>59</b>
<b>Electrical Overcurrent Protection other than Generators and Motors .....</b>	<b>59</b>
<b>Electrical Power Sources, Generators and Motors.....</b>	<b>60</b>
<b>Electrical Systems .....</b>	<b>60</b>
<b>Fuel Shutoff .....</b>	<b>61</b>
<b>Fuel System .....</b>	<b>61</b>
<b>General Alarms .....</b>	<b>62</b>
<b>General Requirements for Propulsion, Steering and Related Controls on Vessels that Move Tank Barges Carrying Oil or Hazardous Material in Bulk .....</b>	<b>63</b>
<b>Pilothouse Alerter System.....</b>	<b>63</b>
<b>Piping Systems and Tanks .....</b>	<b>64</b>
<b>Pressure Vessels .....</b>	<b>64</b>
<b>Pumps, Piping, Valves and Fittings for Essential System.....</b>	<b>65</b>
<b>Readiness and Testing.....</b>	<b>65</b>
<b>Shipboard Lighting.....</b>	<b>67</b>
<b>Steering Systems .....</b>	<b>67</b>
<b>System Isolation and Markings .....</b>	<b>68</b>
<b>Towing Machinery.....</b>	<b>68</b>
<b>Navigation Safety Equipment .....</b>	<b>70</b>
<b>Introduction .....</b>	<b>70</b>
<b>Automatic Identification System (AIS) .....</b>	<b>70</b>
<b>Communications .....</b>	<b>70</b>
<b>Echo Depth-Sounding Device.....</b>	<b>71</b>
<b>Electronic Position-Fixing Device .....</b>	<b>71</b>
<b>Internal Communications.....</b>	<b>72</b>
<b>Magnetic Compass or Swing Meter .....</b>	<b>72</b>
<b>Marine Radar .....</b>	<b>72</b>
<b>Navigation Lights and Shapes.....</b>	<b>73</b>
<b>Searchlight.....</b>	<b>73</b>
<b>Sound Producing Device .....</b>	<b>73</b>
<b>Operations .....</b>	<b>75</b>
<b>Auto Pilot.....</b>	<b>75</b>



<b>Compressed Gasses</b> .....	75
<b>Emergency Drills and Instruction</b> .....	75
<b>Emergency Duties and Duty Stations</b> .....	76
<b>Examinations and Tests</b> .....	76
<b>Fall Overboard Prevention</b> .....	76
<b>First Aid Equipment</b> .....	77
<b>Fuel for Cooking, Heating, and Lighting</b> .....	77
<b>General Vessel Operation</b> .....	77
<b>Hazardous Ships Stores</b> .....	78
<b>Health and Safety Plan</b> .....	78
<b>Inspections and Testing Before Installations, Alterations or Repairs that Involve Hot Work</b> .....	80
<b>Navigation Assessment</b> .....	80
<b>Navigational Safety Equipment</b> .....	81
<b>Navigation Safety Training</b> .....	82
<b>Official Logbook</b> .....	82
<b>Personnel Records</b> .....	83
<b>Refrigerants</b> .....	84
<b>Towing Vessel Record (TVR) or Record Specified by TSMS</b> .....	84
<b>Vessel Stability</b> .....	85
<b>Wearing of Work Vests</b> .....	85
<b>Pollution Prevention Equipment</b> .....	86
<b>Marine Sanitation Device (MSD)</b> .....	86
<b>Oil Pollution Prevention</b> .....	87
<b>Security</b> .....	90
<b>Cybersecurity</b> .....	90
<b>MTSA and ISPS</b> .....	90
<b>Towline and Terminal Gear</b> .....	92
<b>Introduction</b> .....	92
<b>Recordkeeping for Towing Gear</b> .....	92
<b>Terminal Gear</b> .....	93
<b>Towing Gear</b> .....	96

<b>Towline and Terminal Gear .....</b>	<b>100</b>
<b>TPO (Third-Party Organizations) and TSMS (Towing Safety Management System).....</b>	<b>101</b>
<b>Third Party Organizations.....</b>	<b>101</b>
<b>Towing Safety Management Systems .....</b>	<b>101</b>

# Appeals and Alternate Compliance Options

## Alternate Standards

Towing vessels that comply with SOLAS Chapter II-2 (Construction – Fire protection, fire detection and fire extinction) are deemed to be in compliance with Subchapter M fire protection requirements.

Towing vessels that comply with SOLAS Chapter III (Life-saving appliances and arrangements) are deemed to be in compliance with Subchapter M lifesaving requirements. In addition, towing vessels that operate on an international voyage would also need to meet the applicable requirements of 46 CFR Subchapter W.

Objective evidence of compliance with SOLAS Chapter II-2 and III could be a valid SOLAS Safety Equipment Certificate; however, other forms of objective evidence can be considered on a case-by-case basis.

Towing vessels built to meet SOLAS requirements are deemed to be in compliance with 46 CFR Subchapter M Part 144 design and construction standards. Objective evidence of being built to meet SOLAS requirements for design and construction could be a valid SOLAS Cargo Ship Safety Construction Certificate; however other forms of objective evidence can be considered on a case-by-case basis.

Classed towing vessel are deemed to be in compliance with Subchapter M structure, stability and watertight integrity standards outlined in 46 CFR 144 Subparts B and C.

### Regulatory Cites:

[46 CFR 136.112](#) Incorporation by reference

[46 CFR 141.105](#) Applicability

[46 CFR 142.205](#) Alternate standards

[46 CFR 144.120](#) A classed vessel

[46 CFR 144.130](#) A vessel built to the International Convention for the Safety of Life at Sea, 1974, as amended, requirements

## Alternative Means

46 CFR 141.225 allows a Third Party Organization (TPO) to approve alternative means for complying with 46 CFR 141.340 (lifejackets), 141.350 (Immersion suits), and 141.360 (lifebuoys) for vessels that utilize a TSMS. Minimum criteria that must be met before an alternate means of complying with the above listed requirements can be granted by a TPO are found in respective regulatory sections – i.e. 46 CFR 141.340 for lifejackets.

### Regulatory Cites:

[46 CFR 141.225](#) Alternate arrangements or equipment

[46 CFR 141.340](#) Lifejackets

[46 CFR 141.350](#) Immersion suits

[46 CFR 141.360](#) Lifebuoys

## Appeals

Filing a formal appeal is the process for an owner/operator of inspected vessels to follow when there is disagreement concerning the meaning, interpretation, or application of requirements with the Coast Guard Towing Vessel National Center of Expertise (TVNCOE), a Coast Guard District Commander, a Coast Guard Officer in-Charge, Marine Inspection (OCMI), a classification society, or a Third Party Organization (TPO). Efforts to resolve disagreements should always be made at the lowest level possible; however, when resolution cannot be found, the owner/operator has the right to initiate an appeal. The appeal process used is determined by the event, person, or organization that initiated the decision or action being appealed. To avoid delays in processing an appeal, an owner/operator should carefully read the requirements for initiating the same:

1. TVNCOE actions/determination: 46 CFR 1.03-55(c)
2. District Commander or OCMI actions/determination: 46 CFR 1.03-55(d)
3. Vessel surveys: 46 CFR 1.03-55(a)
4. ISM SMS audits: 33 CFR 96.495
5. TSMS audits: 46 CFR 1.03-55(b)
6. RCP SMS audits: The American Waterways Operators Responsible Carrier Program Section III paragraph B Dispute Resolution Policy.

Additional information within Subchapter M related to appeals can be found in [46 CFR 136.180](#) and [139.155](#). Section 136.180 discusses appeals directly related to Coast Guard decisions and Section 139.155 discusses appeals related to the suspension or revocation of a TSMS approval by a TPO.

### Regulatory Cites:

[33 CFR 96.495](#)  
[46 CFR 1.03-55](#)

### Additional Guidance:

[The American Waterways Operators Responsible Carrier Program Roadmap to Successful Submissions: Exemptions, Appeals & Equivalencies - A Guide for Owner/Operators of Commercial Vessels](#)  
[NVIC 16-82 Appeal of Coast Guard Commercial Vessel Decisions and Actions](#)

## Electronic Certificates

Under certain conditions, electronic certificates can be a practical alternative to paper certificates provided there is a reliable method to verify the validity and authenticity of the certificate(s). CG-CVC Policy letter 17-09 has been developed based on the guidance provided in FAL.5/Circ.39 Rev.2 “Guidelines for the Use of Electronic Certificates” and details the provisions under which electronic certificates may be issued by an ACS, RO, or TPO to U.S. Flag vessels.

### Additional Guidance:

[CG-CVC Policy Letter 17-09 - Issuance and Acceptance of Electronic Certificates](#)

## Equivalents

Towing vessel owners who would like to utilize alternate arrangements or equipment for Subchapter M compliance should request an equivalency. In accordance with 46 CFR 136.115, the Coast Guard may approve any arrangement, fitting, appliance, apparatus, equipment, calculation, information, or test that provides an equivalent level of safety established by Subchapter M. Equivalency requests are submitted through the cognizant OCMI.

### Regulatory Cites:

[46 CFR 136.115 Equivalents](#)

### Additional Guidance:

[Marine Safety Center Marine Technical Note MTN 1-17 Roadmap to Successful Submissions: Exemptions, Appeals & Equivalencies – A Guide for Owner/Operators of Commercial Vessels](#)

## Exemptions

Exemptions are written requests to the OCMI for relief from meeting a specific regulation. Not all regulations allow exemptions. Exemptions are very specific and cover only portions of a subpart or section. If an exemption is allowed it will be clearly stated in the regulation. If there is no statement allowing an exemption for a particular regulation or portion of the regulation then there is no exemption allowed in that instance, and another avenue, such as an equivalency must be used to address the issue.

### Additional Guidance:

[Roadmap to Successful Submissions: Exemptions, Appeals & Equivalencies – A Guide for Owner/Operators of Commercial Vessels](#)

## Excepted Vessels

Towing vessels that meet the definition of an “excepted vessel” are exempt by regulation from compliance with certain regulatory sections of Subchapter M. The definition of an excepted vessel can be found in 46 CFR 136.110. Being an excepted vessel does not exempt a vessel from having to comply with Subchapter M in its entirety. Excepted vessels are focused and limited to specific sections within Subchapter M Parts 142 and 143. If an excepted vessel does not need to comply with a section it will explicitly state the same within the section.

**Regulatory Cites:**

[46 CFR 136.110](#) definitions

**Special Consideration**

The cognizant OCMI who issues the COI may give special consideration(s) authorizing departures from specific regulatory requirements. Special considerations are only granted when unusual circumstances or arrangements warrant such departures and when an equivalent level of safety is provided. Special consideration determinations are based on a review of relevant information, including any TSMS applicable to the vessel. See CVC-WI-010(1) *OCMI Guidance on Special Consideration for 46 CFR Subchapter M Vessels* for detailed guidance. As an alternative, for vessels that operate in multiple OCMI zones, the owner/managing operator may seek an equivalency as outlined in 46 CFR 136.115.

**Regulatory Cites:**

[46 CFR 136.115](#) Equivalents

[46 CFR 136.120](#) Special consideration

[46 CFR 144.215](#) Special Consideration

**Additional Guidance:**

[CVC-WI-010\(2\) OCMI Guidance on Special Consideration for 46 CFR Subchapter M Vessels](#)

[Marine Safety Center Marine Technical Note MTN 1-17](#)

[Roadmap to Successful Submissions: Exemptions, Appeals & Equivalencies – A Guide for Owner/Operators of Commercial Vessels](#)

# Construction and Arrangement

## Combustibles Insulated From Heated Surfaces

Engine and galley exhaust ducts, installed on new and existing vessels, must be appropriately insulated. Insulation installations must be to the satisfaction of the OCMI or TPO as appropriate. Compliance with ABYC P-1 or NFPA 302 is objective evidence of compliance with this requirement.

### Items to check:

- Internal combustion engine exhaust ducts, galley exhaust ducts, and similar ignition sources properly insulated if less than 18 inches (450mm) away from combustible material.

### Regulatory Cites:

46 CFR 136.112  
46 CFR 144.415

### Additional Guidance:

ABYC Standard P-1  
NFPA Standard 302

## Crew Spaces

A definition for “rest” can be found in 46 CFR 15.1101(a)(4).

### Items to check:

- Accommodation and work spaces suitable for the size, facilities service, route and modes of vessel operation.
- Accommodation space overhead not located below the deepest load waterline.
- Overnight accommodations if the same crew operates the vessel more than 12 hours in a 24 hour period.
- Provide suitable environment for sleep and off-duty rest.

### Regulatory Cites:

46 CFR 15.1101 General  
46 CFR 144.700 General requirements  
46 CFR 144.710 Overnight accommodations  
46 CFR 144.720 Crew rest consideration

### Additional Guidance:

Marine Safety Manual Volume II

## Design Verification

There is no requirement in Subchapter M for new construction oversight by the Coast Guard or a TPO; however, TPOs who will be providing such oversight should develop their own oversight process and incorporate the same into their Quality Management System.

New towing vessels are required to verify compliance with Subchapter M design standards prior to issuance of the initial COI. Deviations from the verified design standards will need to be corrected before the vessel enters service. Existing towing vessels must have their proposed modifications verified for compliance with design standards prior to the modifications.

Verification of compliance with design standards conducted by a licensed professional engineer (PE) or a classification society are not conducted under the guidance of NVIC 10-82 or NVIC 10-92, so these verifications are not required to be submitted to the Coast Guard for final approval or authorization.

If the owner or managing operator would like the Coast Guard to conduct the design verification, they must first submit Form CG-3752, "Application for Inspection of U.S. Vessel," to the cognizant OCMI where the construction will take place. The local OCMI will then provide guidance as to which plans are required for submission and identify which, if any, will be forwarded to the MSC for review.

### Items to check:

- Required design verification complete IAW 46 CFR Part 144
- No deviations from verified design standards

### Regulatory Cites:

[46 CFR 144.135](#) Verification of compliance with design standards

[46 CFR 144.140](#) Qualifications

[46 CFR 144.145](#) Procedures for verification of compliance with design standards

### Additional Guidance:

[NVIC 10-82, CH-2](#) Acceptance of Plan Review and Inspection Tasks Performed by the American Bureau of Shipping for New Construction or Major Modifications of U.S. Flag Vessels

[NVIC 10-92 CH-2](#) Coast Guard Recognition of Registered Professional Engineer Certification of Compliance with Coast Guard Requirements

[Marine Safety Center Technical Note 01-17](#), Guidance on Design Verification for Subchapter M Towing Vessels

[Marine Safety Center Design Verification Guideline Number H1-18](#), Review of General Arrangements for Towing Vessels

## Guards in Dangerous Places

### Items to check:

- All exposed hazards such as gears and rotating machinery are protected by cover, guard or rail.
- Access to equipment such as towing gear, steering gear, winches, drums and other equipment needed in the operation of the vessel not restricted by guards.

### Regulatory Cites:

[46 CFR 144.820](#) Guards in dangerous places



## Handrails and Bulwarks

Certain towing vessels subject to Subchapter M, handrails will also need to meet minimum height requirements – i.e. Loadline vessels).

### Items to check:

- Rails or equivalent protection installed near periphery of all decks accessible to crew.
- Hand grabs are available in locations where deck rails are impractical.

### Regulatory Cites:

[46 CFR 144.800](#) Handrails and bulwarks

## Lifting Requirements

New Towing vessels must meet the requirements of 46 CFR part 173, Subpart B.

### Regulatory Cites:

[46 CFR 144.310](#) Lifting requirements for a new vessel.

[46 CFR Part 173, Subpart B](#) Lifting

## Machinery Spaces, Fuel Tank Spaces and Accommodation Spaces

### Items to check:

- Bulkheads separate machinery and fuel tank spaces from accommodation spaces.

### Regulatory Cites:

[46 CFR 144.410](#) Separation of machinery and fuel tank spaces from accommodation spaces

## Markings

### Items to check:

- Hull of documented vessel marked as required by 46 CFR Part 67.
- Hull of undocumented vessel marked with its name and hailing port.
- Vessel complying with 144.300(a) or 144.305 must have draft marks that meet requirements of 46 CFR 97.40-10
- Loadline vessel has loadline marks and deck line permanently scribed or embossed as required by 46 CFR Part 69 Subchapter E.
- Watertight doors and hatches marked in accordance with 144.160 (e)
- Emergency and escape hatches marked in accordance with 144.160 (f)

### Regulatory Cites:

[46 CFR 67](#) Documentation of Vessels

[46 CFR 69](#) Measurement of Vessels

[46 CFR 97.40-10](#) Draft marks and draft indicating systems

[46 CFR 144.160](#) Marking

46 CFR 144.300 Stability standards for an existing vessel  
46 CFR 144.305 Stability standards for a new vessel

## **Mattresses**

### **Items to check:**

- Each mattress complies with either:
  - U.S. Department of Commerce Standard for Mattress Flammability (FF 4-72.16) 16 CFR part 1632 Subpart A and not contain polyurethane foam.
  - IMO Resolution A.688 (17) Fire test procedures for ignitability of bedding components.

### **Regulatory Cites:**

46 CFR 144.430

### **Additional Guidance:**

16 CFR Part 1632, Subpart A  
IMO Resolution A.688 (17)

## **Means of Escape**

NVIC 9-97 Ch-1 provides guidance regarding means of escape on commercial vessels.

46 CFR 144.515(b) is one of the parameters (no sources of fire) that must be met in order to utilize one means of escape from a space. For the purposes of this subparagraph, a portable heater with an open flame, resistance coil, or fuel source is considered a source of fire. An installed baseboard or wall-mounted radiator/vent in a space should not be considered a source of fire.

### **Items to check:**

- Each crew living and working space has adequate number of means of escape.
- Located at opposite end or sides of space - may include passageways, stairways, ladders, deck scuttles, doors, and windows.
- If window is used as a means of escape meets requirements of 144.510.
- If utilizing one means of escape from a space meets requirements of 144.515

### **Regulatory Cites:**

46 CFR 144.500 Means of escape  
46 CFR 144.505 Location of escapes  
46 CFR 144.510 Window as a means of escape  
46 CFR 144.515 One means of escape required

### **Additional Guidance:**

NVIC 9-97 Ch-1 Guide to Structural Fire Protection

## Operating Station Visibility

### Items to check:

- Windows at operating station provide clear field of vision for safe operation in any weather condition.
- Windows forward of the operating station in the pilot house have means to ensure safe navigation regardless of weather conditions:
  - Windshield wipers
  - Clear-view Screens
  - Defoggers

### Regulatory Cites:

[46 CFR 144.905](#) Operating station visibility

## Protection Against Hot Piping

### Items to check:

- Exhaust pipes from internal combustion engines within reach of personnel are insulated and/or guarded.
- New vessels each pipe that contain vapor, gas, or liquid that exceeds 150°F or 65.5°C within reach of personnel must be insulated and/or guarded.

### Regulatory Cites:

[46 CFR 144.830](#) Protection against hot piping

## Stability Standards

Further discussion about stability standards can be found in the Part 144 FAQs.

### Items to check:

- Any stability documents issued to the vessel are readily available.
- If a new towing vessel, meets the applicable stability standards of [46 CFR Part 170](#) and [173](#).

### Regulatory Cites:

[46 CFR 144.300](#) Stability standards for an existing vessel

[46 CFR 144.305](#) Stability standards for a new vessel

### Additional guidance:

[Marine Safety Center DVG Number H1-04](#), Review Stability for Towing Vessels (M)

[NVIC 14-81](#), Stability Tests; Waiving of for “Sister Vessels”

[NVIC 10-83](#), Stability Approval and the Issuance of Stability Letters

[NVIC 12-83](#), Intact Stability of Towing Vessel and Fishing Vessels; Research Results

[NVIC 17-91](#), Guidelines for Conducting Stability Tests

[Marine Safety Manual Volume II](#)

[FAQs Part 144](#) – see 144-001, -003, -014, -024

## Storm Rails

Certain towing vessels subject to Subchapter M, handrails will also need to meet minimum height requirements – i.e. Loadline vessels.

### Items to check:

- Storm rails or hand grabs installed in all passageways and deckhouse sides.

### Regulatory Cites:

[46 CFR 144.810](#) Storm rails

## Structural Standards

The OCMI may consider a vessel as “overbuilt” when compared to acceptable construction standard(s), such as ABS Rules for Steel Vessels Under 90 Meters (295 Feet) in Length. Requests for increased wastage allowance based on the vessel being overbuilt may be submitted in writing to the local OCMI. Requests should offer suitable verification, including objective evidence showing the vessel’s scantlings, (frames, girders, plating, etc.). NVIC 7-68 and the Part 144 FAQs may be referenced for further clarification.

### Items to check:

- Meets structural standards for the intended service and route(s) per ABS Rules for Building and Classing Steel Vessels Under 90 Meters (295 Feet) in Length.
- Meets structural standards for the intended service and route(s) per ABS Rules for Building and Classing Steel Vessels for Service on Rivers and Intracoastal Waterways.
- Vessel has been in satisfactory service and has proven structurally adequate.

### Regulatory Cites:

[46 CFR 144.120](#) A classed vessel

[46 CFR 144.125](#) A vessel with a load line

[46 CFR 144.130](#) A vessel built to the International Convention for the Safety of Life at Sea, 1974, as amended, requirements

[46 CFR 144.200](#) Structural standards for an existing vessel

[46 CFR 144.205](#) Structural standards for a new vessel

[46 CFR 144.215](#) Special consideration

### Additional Guidance:

[NVIC 7-68](#) Notes on Inspection and Repair of Steel Hulls

[FAQs Part 144](#) – see 144-013, -023, -048

## Ventilation

An additional hazard in the event of fire is the spread of smoke through ventilation systems. Operation of ventilation dampers and smoke flaps should be verified. The marine inspector should also ensure that the master controls de-energization of ventilation fans operates as intended and that means are available for closing main inlets and outlets of ventilation systems. The requirements of 144.605 are independent of the requirements for fixed fire extinguishing systems in part 142 and are applicable to all vessels, regardless of fire suppression systems onboard.

**Items to check:**

- Means available to stop each fan in a ventilation system serving a machinery space.
- Means of closing each doorway, ventilator, annular space around funnels or other openings in case of fire.
- If vessel is greater than 65 ft in length and has overnight accommodations:
  - Vessel has mechanical ventilation or sufficient natural ventilation available.

**Regulatory Cites:**

46 CFR 144.605 Means to stop fans and close openings

46 CFR 144.610 Ventilation in a vessel more than 65 feet in length

**Waste Receptacles****Items to check:**

- All waste receptacles constructed of non-combustible materials with no openings on sides or bottom.

**Regulatory Cites:**

46 CFR 144.425 Waste receptacles

**Watertight or Weathertight Integrity****Items to check:**

- Scuppers and freeing ports on installed bulwarks not blocked.
- Closer devices for deckhouse or hull penetrations that open to exterior of vessel operate properly.

**Regulatory Cites:**

46 CFR 144.320 Watertight or weathertight integrity

**Additional guidance:**

NVIC 2-62 Watertight Bulkheads in All Inspected Vessels Maintenance of Watertight Integrity

**Window or Portlight Strength****Items to check:**

- Windows, portlights, and its means of attachment to the hull suitable for maximum load expected from wind waves.
- Coverings or protection over a window or portlight used as an escape readily removed or opened from within the space.
- Windows made of materials that will not fracture into dangerous fragments if fractured.

**Regulatory Cite:**

46 CFR 144.920 Window or portlight strength in a new vessel.

## Credentials, Documents and Reports

### Ballast Water Management

Vessels equipped with ballast tanks may elect to retain ballast on board or use an alternative environmentally sound method of ballast water management that has been submitted to and approved by the Coast Guard prior to the voyage. If the alternative environmentally sound method of ballast water management is inoperative, the vessel may discharge only the amount of ballast water operationally necessary to ensure the safety of the vessel.

Many towing vessels on Western Rivers routes use treated city water supplies for ballast. Under most circumstances, the discharge of treated city water should be considered an alternative environmentally sound method of ballast water management.

There are mandatory ballast water reporting and recordkeeping requirements for towing vessels equipped with ballast tanks.

#### Regulatory Cites:

[33 CFR 151.2060](#) Reporting requirements  
[33 CFR 151.2070](#) Recordkeeping requirements

#### Additional Guidance:

[NVIC 01-18](#) Ballast Water Management for Control of Non-Indigenous Species in Waters of the United States

### Determining Manning Levels

The cognizant OCMI is responsible for establishing manning levels for each towing vessel based on statutory and regulatory requirements and with consideration given to factors including, but not limited to, vessel size, service and route.

Manning guidance and sample manning scales for towing vessels inspected under Subchapter M can be found in Parts B and C of Marine Safety Manual Volume III: Marine Industry Personnel. Relevant sections are listed below for ease of reference (not all inclusive):

Chapter B1, General Provisions for Vessel Manning (NOTE: Annex Attachment (1) contains a Suggested Template: Minimum Safe Manning Proposal);  
Chapter B2, Section W: Sample Manning Scales for Towing Vessels Inspected under 46 CFR Subchapter M;  
Chapter B2, Section X: Manning and STCW Certification Reference Tables (Seagoing Vessels);  
Chapter B3, Section B: Impact of International Standards (OCCC '36, STCW, ITC, SOLAS, IMO Resolution A.1047(20));  
Chapter B3, Section C: Masters;  
Chapter B3, Section D: Mates;  
Chapter B3, Section E: Chief Engineer;  
Chapter B3, Section F: Engineers;  
Chapter B3, Section G: Master and Mate (Pilot) of Towing Vessels;  
Chapter B4, Section D: Deck Department Manning;  
Chapter B4, Section E: Engineering Department Manning;  
Chapter B5, Section A: Watchstanding Requirements on U.S. Vessels;

Chapter B5, Section C: Work Hour Limitations;  
Chapter B5, Section E: International Standards Relating to Working Conditions (STCW, ILO 147, ILO MLC);  
Chapter B6, Section A: Manning Requirements  
Chapter C2, Section A: Deck Officer Endorsements (Routes, Tonnage, Grade, Equivalentents, Trade Restrictions);  
Chapter C2, Section B: Engineer Officer Endorsements (Propulsion Power, Grade, Equivalentents, Trade Restrictions);  
Chapter C2, Section C: Deck Ratings;  
Chapter C2, Section D: Engine Ratings;  
Annex Attachment (1): Suggested Template – Minimum Safe Manning Proposal; Annex Attachment (3): Master’s Field Guide – U.S. Vessel manning

**Regulatory Cite:**

[46 CFR 15.501](#) Certificate of inspection

**Additional Guidance:**

[Marine Safety Manual Volume III](#)

**Documentation**

A Certificate of Documentation (COD) is valid for one year from date of issue.

A coastwise endorsement entitles a vessel to employment in unrestricted domestic trade, dredging, towing, and any other employment for which a registry, OR fishery endorsement is not required. If the vessel operates on a foreign voyage it must have a registry endorsement.

The official number of the vessel, preceded by the abbreviation: “NO.” must be marked in block-type Arabic numerals not less than three inches in height on some clearly visible interior structural part of the hull. The number must be permanently affixed so that alteration, removal, or replacement would be obvious. If the official number is on a separate plate, the plate must be fastened in such a manner that its removal would normally cause scarring of or damage to the surrounding hull area.

The name of the vessel must be marked on some clearly visible exterior part of the port and starboard bow and the stern of the vessel. It must be made in clearly legible letters of the Latin alphabet or Arabic or Roman numbers not less than four (4) inches in height. If used, name boards must be rigidly attached. The hailing port of the vessel must be marked on some clearly visible exterior part of the stern of the vessel. For vessels with a square bow, the name of the vessel must be marked on some clearly visible exterior part of the bow in a manner to avoid obliteration. The name and hailing port must be marked on some clearly visible exterior part of the stern.

**Items to check:**

- Properly endorsed and valid Certificate of Documentation (COD) on board.
- Official Number properly marked and clearly visible on an interior structural part of the hull.
- Name of the vessel marked and clearly visible on exterior part of the port and starboard bow and the stern of the vessel.

**Regulatory Cites:**

[46 CFR 67.19](#) Coastwise Endorsement  
[46 CFR 67.121](#) Official Number Marking Requirement

46 CFR 67.123 Name and hailing port marking requirements  
46 CFR 67.313 Requirement to have Certificate of Documentation on board

## Drug and Alcohol Testing

### Items to check:

- Company participates in a drug testing program or consortium.
- Operator knowledgeable about general rules for intoxicant use.
- Employee Assistance Program in place:
  - Display and distribution of informational material:
    - A community service hot-line telephone number for crewmember assistance.
    - Employer's policy regarding drug and alcohol use in the workplace.
  - A training program the includes:
    - The effects and consequences of drug and alcohol use on personal health, safety, and work environment.
    - The manifestations and behavioral cues that may indicate drug and alcohol use and abuse.
- Vessel carries devices or has arrangements to perform alcohol testing w/in 2 hours & drug testing w/in 32hrs after a serious marine incident.

### Regulatory Cites:

46 USC 3301 Vessels subject to inspection  
46 CFR 4.03-1 Marine casualty or accident  
46 CFR 4.03-2 Serious marine incident  
46 CFR 4.06 Mandatory chemical testing following serious marine incidents involving vessels in commercial service  
46 CFR 4.06-1 Responsibilities of the marine employer  
46 CFR 4.06-3 Requirements for alcohol and drug testing following a serious marine incident  
46 CFR 16.105 Definitions of terms used in this part (Chemical Testing)  
46 CFR 16.210 Pre-employment testing requirements  
46 CFR 16.220 Periodic testing requirements  
46 CFR 16.230 Random testing requirements  
46 CFR 16.240 Serious marine incident testing requirements  
46 CFR 16.250 Reasonable cause testing requirements  
46 CFR 16.260 Records  
46 CFR 16.401 Employee Assistance Program (EAP)

## FCC

Towing vessels 26 ft or over in length, while underway on the Navigable Waters of the United States, must have two radiotelephones on board capable of operation from its navigational bridge, and capable of transmitting and receiving on the frequency or frequencies within the 156-162 MHz band for the exchange of navigational information. The radiotelephones must be capable of transmitting and receiving on VHF FM channel 13 (156.65 MHz) while also maintaining a continuous listening watch on the International Distress and Calling Channel, VHF FM Channel 16 (156.800). A single VHF-FM radio capable of scanning or sequential monitoring ("dual watch" capability) will not meet the requirements for two radios. Some towing vessel will also need the capability to transmit and receiving on VHF FM channel 67 (156.375 MHz) – see 33 CFR 166.200. Vessels operating within a Vessel Traffic Service area must meet additional transmitting and receiving capabilities – see 33 CFR Table 161.12(c).

## Credentials, Documents and Reports



## FCC Ships Station License:

Radio stations in the maritime service must be licensed by the FCC individually or by fleet. Licenses will normally be issued for a term of ten years from the date of original issuance, or renewal. On the license under Radio Service, it should read SB – Ship Compulsory Equipped. If it says SA – Ship Recreational or Voluntarily Equipped under Radio Service it should be corrected at once.

## Station Logs:

Details regarding applicable radiotelephone log entries can be found in 47 CFR 409(f). Per 47 CFR 80.409(a)(1), the log must be kept in an orderly manner and may be kept electronically or in writing.

## Regulatory Cites:

- 33 CFR Part 26 Vessel bridge-to-bridge radiotelephone regulations
- 33 CFR 26.03 Radiotelephone required
- 33 CFR 166.200 Shipping safety fairways and anchorage areas, Gulf of Mexico
- 47 CFR 80.13 Station license required
- 47 CFR 80.25 License term
- 47 CFR 80.161 Operator requirements of the Great Lakes Radio Agreement
- 47 CFR 80.163 Operator requirements of the Bridge-to-Bridge Act
- 47 CFR 80.409 Station logs
- 47 CFR 80.951-971 Radiotelephone installation required for vessels on the Great Lakes
- 47 CFR 80.1065 Global Maritime Distress and Safety System (GMDSS) – Applicability

## Bridge to Bridge Certificate:

The Bridge to Bridge Act (BBA) is found in 33 USC Chapter 24 and the purpose is "...to provide a positive means whereby the operators of approaching vessels can communicate their intentions to one another through voice radio...to...exchange... navigational information, on navigable waters of the United States." The Coast Guard equipment carriage requirements for the BBA are found in 33 CFR Part 26. FCC radiotelephone station operating and technical conditions requirements for the BBA are found in 47 CFR Part 80 Subpart U. Per 33 USC 1203(a)(3), 33 CFR 26.03(a)(3) and 47 CFR 80.1001(c), applicability of the BBA includes every towing vessel of 26 feet or over in length while navigating.

47 CFR 80.1005 requires certain bridge-to-bridge radiotelephone stations to be inspected for compliance with the BBA, and outlines when those inspections are to be conducted. All vessels subject to the BBA that are required to conduct regular radiotelephone station inspections under Part II or III of Title III of Communications Act of 1934 (CA), the Safety Convention (SOLAS), or the Great Lakes Agreement (GLA) are required to have the radiotelephone station inspected for compliance with the BBA at the time of those inspections, and to carry a BBA certificate with a valid endorsement while subject to the BBA. Failure to complete the prescribed inspections would invalidate the Bridge to Bridge certificate.

47 CFR 80.1005 also requires bridge-to-bridge radiotelephone stations to "...be inspected from time to time" for compliance with the BBA on towing vessels not subject to regular inspections under Part II or III of Title III of the CA, SOLAS, or the GLA. The FCC and the Coast Guard consider this to be an inspection required for reasonable cause. Evidence showing a radiotelephone station meets the BBA includes labeling on the radios or other documentation (i.e. manufactures specification sheet) indicating the equipment is 47 CFR Part 80 compliant. If the vessel has the proper equipment and the radio passes a radio check, there should be no further inspection requirements needed. If the radiotelephone appears

## Credentials, Documents and Reports

to be malfunctioning, then prompt repairs should be considered per requirements of 33 CFR 164.72(a)(3) and 164.82. If there is reasonable cause to require an inspection of the radiotelephone to certify compliance with the BBA, and the vessel does not pose an immediate hazard to navigation, the FCC should be notified so they can take action as they deem appropriate. As an alternative to conducting a reasonable cause BBA inspection, replacement of the defective equipment with serviceable BBA compliant equipment is acceptable.

Bridge to Bridger Act (BBA) Summary Table				
Towing Vessel	BBA applicable?	BBA inspection required?	BBA inspection interval?	BBA certificate required? <sup>7</sup>
Seagoing <sup>1</sup> => 300 GRT and =>26 ft. in length; Seagoing carrying more than 12 passengers; or SOLAS requirement to survey radio installation	Yes	Yes <sup>2</sup>	12 months	Yes
Authorized to transport more than six passengers for hire in the open sea <sup>1</sup> or any tidewater adjacent or contiguous to the open sea	Yes	Yes <sup>3</sup>	5 years	Yes
Operates on the Great Lakes and => 26 ft. in length	Yes	Yes <sup>4</sup>	13 months	Yes
Seagoing <sup>1</sup> <300 GRT and =>26 ft. in length; or Inland => 26 ft. in length	Yes	As needed <sup>5</sup>	Time to time	No
< 26ft. in length	No <sup>6</sup>	No	No	No
Notes: 1. Seagoing and open sea include operations beyond the boundary line as defined in 46 CFR Part 7. 2. Vessel is subject to regular inspections under Part II of Title III of the CA. The BBA inspection is conducted at the time of the CA inspection or SOLAS survey. 3. Vessel is subject to regular inspections under Part III of Title III of the CA. The BBA inspection is conducted at the time of the CA inspection. 4. Vessel is subject regular inspections under the GLA. The BBA inspection is conducted at the time of the GLA inspection. 5. Vessel is not subject to regular inspections under Part II or III of Title III of the CA, SOLAS, or the GLA. The bridge to bridge radiotelephones is only inspected under the BBA for reasonable cause. If the vessel has had a reasonable cause BBA inspection, there should be an inspecting technician's entry in the station log or a Bridge-to-Bridge certificate. 6. References: 33 USC 24; 33 CFR 26.03; 47 CFR 80.1001. 7. A properly endorsed Bridge to Bride certificate demonstrates successful completion of a BBA inspection. In lieu of endorsing an inspection on the Bridge to Bridge certificate, compliance can be certified in the station log required by section 47 CFR 80.409(f).				

**Regulatory Cites:**

- 33 USC Chapter 24 Bridge to Bridge Act
- 33 CFR Part 26 Vessel bridge-to-bridge radiotelephone regulations
- 47 CFR 80.901 Applicability
- 47 CFR 80.903 Inspection of radiotelephone installation
- 47 CFR 80.951 Applicability
- 47 CFR 80.953 Inspection and certification
- 47 CFR 80.1005 Inspection of station
- Communications Act of 1934
- SOLAS Chapter 1 Reg 9 and Chapter IV Reg 1.

## Hazardous Conditions Reporting

Hazardous Condition means any condition that may adversely affect the safety of any vessel, bridge, structure, or shore area or the environmental quality of any port, harbor or Navigable Water of the United States. It may, but need not, involve collision, allision, fire, explosion, grounding, leaking, damage, injury or illness of a person on board, or manning shortage.

### Regulatory Cites:

[33 CFR 160.113](#) Prohibition of vessel operation and cargo transfers  
[33 CFR 160.204](#) Exemptions and exceptions

## Load Line

Towing vessels that are subject to the load line requirements must have load lines accurately marked amidships, port and starboard; and must have a valid load line certificate to document the load line survey, the proper placement of the load line marks and any restrictions on vessel operations.

### Items to check:

- Valid load line certificate on board
- Hull properly marked.

### Regulatory Cites:

[46 CFR 136.250](#) Load lines  
[46 CFR 42.07-1](#) Load lines required  
[46 CFR 42.50](#) Load Line Certificates – Model Forms

## Manning

It is the responsibility of the owner, managing operator, and master to ensure that their vessels are operated in accordance with safe manning, working hours and watchkeeping requirements of applicable laws & regulations. This includes making certain that their vessels are crewed with personnel of appropriate grades who have been properly trained and certificated.

The COI serves as the Safe Manning Document (SMD) for the vessel and states the minimum numbers and categories of credentialed crewmembers necessary for safe operations. No vessel may be navigated unless it has in its service and onboard the crew complement required by the COI. In certain cases, a vessel is permitted to be navigated without all of the required positions being filled - refer to Marine Safety Manual Volume III.B1.I and 46 CFR 15.725 for details.

Crewmembers filling a position that requires a MMC must hold signed, appropriate and valid credentials for the position in which they are engaged.

Required MMC endorsements for service on towing vessels can be found in Marine Safety Manual Volume III.B3 Figure B3-2: Towing Endorsement Table (2014, 2017).

If the vessel is 26 ft. or more in length and equipped with radar, each Master or Mate (Pilot) must hold an endorsement as radar observer.

Certain towing vessels are also required to employ credentialed mariners in their deck department (i.e. ABs). Refer to Marine Safety Manual Volume III.B4.D for details.

## Watchstanding

The master is responsible for ensuring that adequate watches are established for both underway and in-port operations that require watchkeeping personnel. Refer to Marine Safety Manual Volume III.B5 for details.

Gross Tonnage	Route	Length of Voyage	Watch System
<100 GRT	Domestic-Any	<12 Hours	1
<100 GRT	Domestic-Any	>12 Hours	2
<200 GRT	Any	Any Length	2
>200 GRT	Rivers, L/B/S	Any Length	2
>200 GRT	Oceans/Coastwise/ Great Lakes	<600 Miles	2
>200 GRT	Oceans/Coastwise/ Great Lakes	>600 Miles	3

The master is also responsible to ensure that workhour limitations are not exceeded. Vessels subject to STCW have additional work hour limits & schedule/recordkeeping requirements. Refer to Marine Safety Manual Volume III.B5 for details.

### Items to check:

- For all routes:
  - Vessel manned in accordance with the Certificate of Inspection.
  - Merchant Mariner Credentials for crewmembers.
  - Individual(s) in charge of navigating or maneuvering the vessel hold an appropriate Merchant Mariner Credential with proper endorsement(s) for the vessels size and route.
  - Valid Transportation Worker Identification Credential (TWIC) for crewmembers needing unescorted access.
- For coastwise and oceans routes only:
  - Crewmembers in a position requiring an STCW endorsement have the proper STCW endorsement(s).
  - Crewmembers completed STCW familiarization a basic safety-training.
  - Vessel complies with STCW Principals of Watchkeeping.
  - Crewmembers comply with rest period requirements of STCW.

## Credentials, Documents and Reports

### **Regulatory Cites:**

33 CFR 89.25 Waters specified by the Secretary  
46 CFR 10.107 Definitions in subchapter B  
46 CFR 10.109 Classification of endorsements  
46 CFR 10.203 Requirement to hold a TWIC and a merchant mariner credential  
46 CFR 10.205 Validity of a merchant mariner credential  
46 CFR 15.610 Master and mate (pilot) of towing vessels  
46 CFR 15.705 Watches  
46 CFR 15.720 Use of non-U.S.-credentialed personnel  
46 CFR 15.725 Sailing Short  
46 CFR 15.812 Pilots  
46 CFR 15.815 Radar Observers  
46 CFR 15.840 Able Seaman  
46 CFR 15.1105 Familiarization and basic training (BT)  
46 U.S.C. subtitle II part E Merchant Seamen Licenses, Certificates, and Documents  
46 USC 7110 Exhibiting Licenses  
46 USC 8104 Watches  
46 USC 8304 Implementing the Officers' Competency Certificates Convention, 1936  
46 USC 8702 Certain crew requirements

### **Additional Guidance:**

[CG-CVC Policy Letter 19-01](#) - Enforcement Guidance for Harbor Assist Towing Vessels When Operating Beyond the Boundary Line

[CG-CVC Policy Letter 19-02](#) - Guidance on the Enforcement of Radar Observer Requirements Prior to 22 July 2019

[NVIC 03-16](#) Licensing and Manning for Officers of Towing Vessels

[NVIC 03-07](#) Transportation Worker Identification Credential (TWIC) Program

[Marine Safety Manual Volume III](#) (2017) Marine Industrial Personnel

## **Marine Casualty Reporting**

For State registered towing vessels, a casualty or accident report must be submitted to the reporting authority of the state who issued the state number, or to the state where the casualty or accident occurred.

For all other towing vessels involved in a marine casualty, notification must be made to the nearest Coast Guard Sector office immediately after addressing resultant safety concerns and, within five days, file a written report of any marine casualty required to be reported under 46 CFR 4.05-1.

### **Regulatory Cites:**

33 CFR 173.51 Casualty and accident reporting  
46 CFR 4.03-65 Significant harm to the environment  
46 CFR 4.05-1 Reports of potential vessel casualty  
46 CFR 4.05-10 Written report of marine casualty

## **MARPOL ANNEX V**

### **Items to check:**

- Written record of garbage discharge or disposal operations. (Only required for oceangoing vessels of 400 gross tons and above)

Oceangoing vessels 40 ft or more in length, or equipped with a galley and berthing, must have a written Waste Management Plan. The plan must provide for the discharge of garbage by means that meet Annex V of MARPOL 73/78, and 33 CFR 151.51 through 151.77 describing procedures for collecting, processing, storing, and discharging garbage; and designates the person who is in charge of carrying out the plan.

Vessels 26 ft or more in length must have one or more garbage placards displayed in prominent locations and in sufficient numbers so that they can be read by the crew. Each placard must be at least nine inches wide by four inches high, made of a durable material, and have lettering at least 1/8 inches high.

**Regulatory Cites:**

- 33 CFR 151.51 Applicability – Garbage Pollution and Sewage
- 33 CFR 151.57 Garbage management plans
- 33 CFR 151.59 Placards
- 33 CFR 151.63 Shipboard control of garbage
- 33 CFR 151.77 Exceptions for emergencies and health risks

**MARPOL ANNEX VI**

MARPOL 73/78, Annex VI entered into force for the United States on January 8, 2009. The guidance in enclosure (1) of CG-543 Policy Letter 09-01 should be used during Sub M inspections/surveys respectively, to ensure all inspected or uninspected towing vessels operating in U.S. waters comply with the provisions of MARPOL 73/78, Annex VI. OCMI's should bring this policy to the attention of appropriate individuals in the marine industry.

The table below summarizes the various Annex VI compliance documentation scenarios:

Inspection Status	Gross Tonnage	Route	Annex VI Documentation
Inspected	≥ 400 ITC	International	IAPP Certificate and EIAPP Certificate, if appropriate
Inspected	≤ 400 ITC	International	Annex VI endorsement on COI
Inspected	Any gross tonnage	Domestic	COI
Uninspected	Any gross tonnage	Domestic	None Required

**Items to check:**

- Checklists can be found for specific vessels depending on Gross Tonnage and Route in Appendix A of Enclosure (1) to CG-543 Policy Letter 09-01.

**Credentials, Documents and Reports**

### **Regulatory Cites:**

40 CFR Part 89 Control of Emissions from New and in-use Nonroad Compression-Ignition Engines  
40 CFR Part 94 Control of Emissions from Marine Compression-Ignition Engines  
40 CFR Part 1039 Control of Emissions from New and in-use Nonroad Compression-Ignition Engines  
40 CFR Part 1042 Control of Emissions from New and in-use Marine Compression-Ignition Engines and Vessels

### **Additional Guidance:**

CG-543 Policy Letter 09-01 Guidelines for ensuring compliance with Annex VI to the International Convention of the Prevention of Pollution from ships (MARPOL) 73/78; prevention of air pollution from ships.

## **Navigation Publications**

Towing vessels must carry currently corrected editions of publications for the area to be transited.

### **Items to check:**

- Charts or maps for area of operation
- USCG Light List for area of operation
- ACOE Notices to Navigation or USCG Local Notice to Mariners (LNM)
- River-current tables (if available)National Geospatial-Intelligence Agency (NGA (formerly NIMA)) Notices to Mariners or USCG Local Notice to Mariners (LNM)Tidal-current or river-current tables
- Tide tables
- USCG Coast Pilot
- Copy of VTS Rules
- Inland Navigation Rules on board

### **Regulatory Cites:**

33 CFR 164.72 Navigational-safety equipment, charts or maps, and publications required on towing vessels  
46 CFR 140 Subpart G - Navigation and Communication Equipment

### **Additional Guidance:**

NVIC 01-16 Use of electronic charts and publications in lieu of paper charts, maps and publications

## **Oil Pollution Prevention Records/Documents**

Towing vessels 26 ft or longer must have a placard posted in each machinery space, or at the bilge and ballast pump control station.

The Person-In-Charge of any transfer of oil requiring a Declaration of Inspection must hold a valid credential authorizing service as a master, mate, pilot, engineer or hold a valid MMC endorsed as Tankerman-PIC or carries a letter satisfying the requirements of 33 CFR 155.715 and designating him or her as a PIC.

Vessels with a capacity of 250 or more barrels (10,500 gallons) of oil must have transfer procedures that meet the requirements of 33 CFR Parts 155 and 156 for transferring oil to or from the vessel, and from tank to tank within the vessel. The procedures must be permanently posted or available at a place where

## **Credentials, Documents and Reports**

the procedures can be easily seen and used by members of the crew when engaged in transfer operations.

Written records must be available with the name of each person currently designated as PIC of transfer operations, the date and result of the most recent tests and inspections, the hose information if not marked on the hose, and declarations of inspection for transfer operations completed during the most recent month.

Vessels carrying oil as a secondary cargo must have an approved Vessel Response Plan divided into sections described in 33 CFR 155.1030, and a geographic-specific appendix for each COTP zone the vessel operates in. Vessels over 400 ITC or that have a fuel capacity of over 2,500 barrels must have a response plan.

### **Regulatory Cites:**

33 CFR 138.100 Non-owning operator's responsibility for identification  
33 CFR 154.500 Hose assemblies  
33 CFR 155.450 Placard  
33 CFR 155.710 Qualifications of person in charge  
33 CFR 155.715 Contents of letter of designation as a person-in-charge of the transfer of fuel oil  
33 CFR 155.720 Transfer procedures  
33 CFR 155.740 Availability of transfer procedures  
33 CFR 155.750 Contents of transfer procedures  
33 CFR 155.820 Records  
33 CFR 155.1030 General response plan requirements  
33 CFR 155.1045 Response plan requirements for vessels carrying oil as a secondary cargo  
33 CFR 155.1065 Procedures for plan submission, approval, requests for acceptance of alternative planning criteria, and appeal  
33 CFR 156.150 Declaration of inspection  
33 CFR Part 155 Oil or hazardous material pollution prevention regulations for  
33 CFR Part 156 Oil and hazardous material transfer  
46 CFR Part 10 Merchant mariner credential

### **Additional Guidance:**

NVIC 01-05 change 1 Interim guidance for the development and review of response plans for nontank vessels

## **Records for Towline for Towing Astern**

### **Items to check:**

- Towline inspection records documented in the TVR, official logbook, or in accordance with TSMS:
  - Type of towline
  - Size of towline
  - Size and service of each towline
  - Initial minimum breaking strength
  - Record of each retest of the towline's minimum breaking strength Visual inspection of towline in accordance with manufacturer's recommendations, or at least monthly, and whenever the serviceability of the towline is in doubt
  - Dates when examinations were performed
  - Identification of each item of towing gear examined



- Name(s) of the person(s) conducting the examinations

**Regulatory Cites:**

46 CFR 140.820 Recordkeeping for towing gear

33 CFR 164.74 Towline and terminal gear for towing astern

33 CFR 164.76 Towline and terminal gear for towing alongside and pushing ahead

**Additional Guidance:**

NVIC 5-92 Guidelines for Wire Rope Towing Hawsers

**Registration**

The vessel must be marked on each side of the forward half of the vessel with a number issued on a certificate of number by the issuing authority in the State in which the vessel is principally used. The number must be in plain vertical block characters of not less than 3 inches in height; contrast with the color of the background and be distinctly visible and legible; must have spaces or hyphens that are equal to the width of a letter between letter and number groupings (Example: DC 5678 EF or DC-5678-EF); and read from left to right. Some states require a commercial endorsement on the certificate of number.

**Items to check:**

- Valid state (commercial) Certificate of Number on board.
- Hull properly marked.

**Regulatory Cites:**

33 CFR 173.15 Vessel number required

33 CFR 173.21 Certificate of number required

33 CFR 173.27 Numbers: Display; size; color

**Tests and Inspections****Items to check:**

- Pre departure records of visual inspections (required for a vessel embarking on a voyage of more than 24 hours or when a new master/operator assumes command):
  - Steering Systems:
    - Main steering gear from alternative power supply (if installed)
    - Verify accuracy of rudder-angle indicator
    - Visual inspection of steering gear and linkage
  - Navigational Equipment.
  - Communications:
    - Internal vessel control communications
    - Vessel-control alarms (if installed)
  - Lights:
    - Navigation lights
    - Search lights
  - Terminal Gear:

- Tackle
- Connections of bridle and towing pendant (if applicable)
- Chafing gear
- Winch brake (if installed)
- Propulsion Systems:
  - Main propulsion machinery
  - Machinery
  - Devices for monitoring machinery
- Records of lifesaving equipment tests and inspections:
  - Date of inspection
  - Number or other identification of each unit tested or inspected
  - Result of inspection or test
  - Name of crewmember, surveyor or auditor conducting inspection or test
  - Receipts and or records of tests/inspections maintained for one year
- Records of firefighting equipment tests, inspections, and maintenance:
  - Inspection and test records (at least every 12 months) for the following:
    - Hand portable fire extinguishers
    - Semi portable fire-extinguishing systems
    - Fire detection systems
    - Fixed fire-extinguishing systems:
      - Ventilation
      - Machinery shutdowns
      - Pressure-operated dampers
  - Date of inspection and tests performed
  - Number or other identification of each unit tested or inspected
  - Name of crewmember, surveyor or auditor conducting inspection or test
  - Receipts and or records of tests/inspections maintained for one year

**Regulatory Cites:**

33 CFR 164.80 Tests, inspections, and voyage planning

46 CFR 140.615 Examinations and tests

46 CFR 141.235 Inspection, testing, and maintenance (lifesaving equipment)

46 CFR 142.240 Inspection, testing, maintenance, and records (firefighting equipment)

46 CFR 199.190 Operational readiness, maintenance, and inspection of life saving equipment

# Fire Protection

## Introduction

Fire detection and suppression systems are considered essential systems – see 46 CFR 136.110. All deficiencies related to fire protection requirements will, in most cases, have to be resolved prior to the vessel getting underway or issuing/endorsing the Certificate of Inspection (COI). All fire equipment or arrangement details not covered within 46 CFR Part 142 must be to the satisfaction of the cognizant Officer in Charge, Marine Inspection (OCMI).

It is critical that fire protection systems and equipment function as designed when needed. Improper fire protection system and equipment testing can cause system/equipment degradation or complete failure, crewmember injury(s), death(s) and/or catastrophic damage to the vessel. Testing to verify compliance should only be conducted by properly trained personnel using procedures outlined in the approved equipment manufacturer's nameplate and/or the approved operations manual. Inspectors and TPOs can require the vessel owners and/or operators provide notification prior to conducting any fire protection system tests so they can attend the vessel to witness the test(s). To avoid delays in the inspection/survey process the owner/operator and the inspector/TPO should discuss which fire protection systems and equipment will need to be tested during the inspection/survey.

Some fire protection systems and equipment requirements are found in standards that have been incorporated by reference (IBR) in accordance with 46 CFR 136.112. IBR allows Federal agencies to establish requirements using standards already published elsewhere. This means all applicable parts of the IBR standards have the full force of regulation. 46 CFR Part 142 contains numerous sections that utilize IBR standards that come from various organizations such as the National Fire Protection Association (NFPA) and Underwriters Laboratories (UL). The inspector or TPO should have access to, become familiar with, and use these IBR standards when and where applicable to ensure full vessel compliance.

The flowchart contained in this enclosure provides a visual high-level representation of the towing vessel fire protection equipment requirements contained in 46 CFR Part 142. It should not be used as a standalone tool for determining vessel compliance. Flowchart notes:

1. The carriage requirements listed are for domestic routes.
2. Carriage requirements will need to be adjusted if specialized or additional equipment has been required by the OCMI.

## General Fire Protection Equipment Requirements

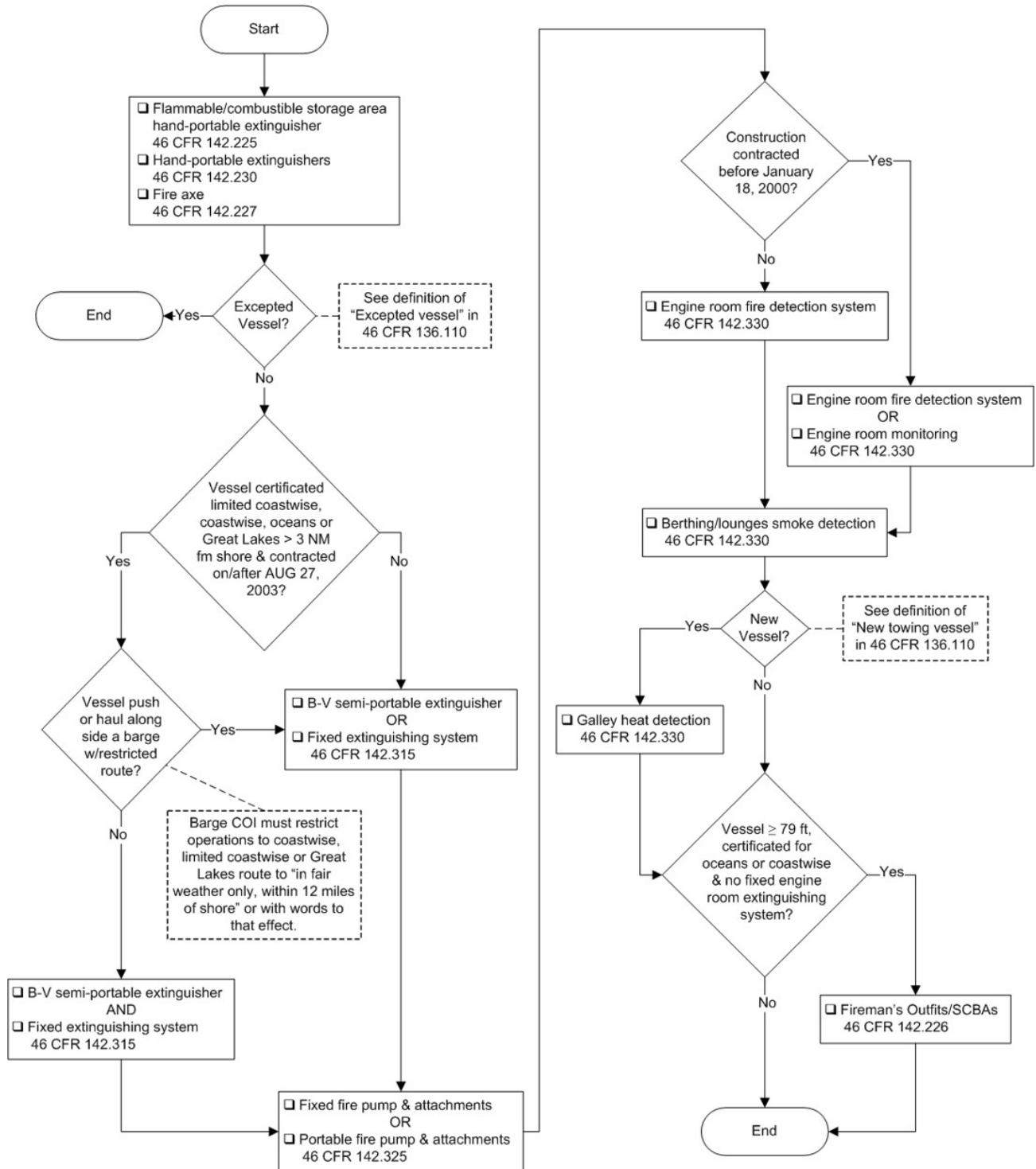

**Fire Protection**

## Additional Fire Extinguishing Equipment

46 CFR Table 142.240 summarizes the minimum tests and inspections required for semi-portable and fixed fire-extinguishing systems.

46 CFR 142.231(a) allows the OCMI to permit existing towing vessels to continue to utilize previously installed fire extinguishers with extinguishing capacities smaller than what is required so long as they are maintained in good condition to the satisfaction of the OCMI. All new equipment and installations must meet the applicable requirements for new vessels.

Semi-portable extinguishers fitted with wheels must be properly secured.

Towing vessels can carry more fire suppression equipment than the minimum carriage requirements as excess equipment provided the equipment meets the same approval standard(s) as those outlined for the required equipment and the equipment is maintained in good and serviceable condition. Guidance on excess equipment can be found in MSM Vol. II.

### Items to check:

- As required, vessel is equipped with a 160-B semi-portable fire-extinguishing system and/or a fixed fire extinguishing system.
- If equipped, semi-portable fire-extinguishing systems Coast Guard approved under approval series 46 CFR 162.039.
- If equipped, fix fire-extinguishing system approved by Commandant and meets:
  - [46 CFR 76.15](#), [78.47-9](#) and [78.47-11](#) if a carbon dioxide system.
  - [46 CFR 95.16](#) and [97.37-9](#) if a clean agent system.
  - NFPA 750 if a water mist system.
- System inspected and tested annually by a qualified person.
- Records of inspections and tests recorded in the TVR, official logbook, in accordance the TSMS or, for a semi-portable fire-extinguishing system, on a tag attached to the unit. Records contain the following information:
  - Dates when inspections and tests were performed.
  - The number and any other identification of each unit inspected and tested.
  - Results of the inspections and tests.
  - The name of the person(s) who conducted the inspections and tests.
- Receipts and other records generated by inspections and tests retained for at least 1 year.

### Regulatory Cites:

[46 CFR 136.110](#) Definitions

[46 CFR 142.215](#) Approved equipment

[46 CFR 142.230](#) Hand-portable fire extinguishers and semi-portable fire-extinguishing systems

[46 CFR 142.231](#) Exception for portable and semi-portable fire extinguishers required for existing vessels

[46 CFR 142.240](#) Inspection, testing, maintenance, and records

[46 CFR 142.315](#) Additional fire-extinguishing equipment requirements

[46 CFR 147.60](#) Compressed Gasses

[46 CFR 147.65](#) Carbon dioxide and halon fire extinguishing systems

[46 CFR 147.67](#) Halocarbon fire extinguishing systems

### Additional Guidance:

Commandant (CG-ENG-4) Lifesaving and Fire Safety Division  
Marine Safety Manual Volume II

CG-CVC Policy Letter 18-04 - Guidance On Implementation Of New Standards For Fire Protection, Detection, And Extinguishing Equipment  
NVIC 6-72 Guide to Fixed Fire-Fighting Equipment Aboard Merchant Vessels  
NVIC 3-95 Periodic Inspection and Testing of Fixed Halon Fire Fighting Equipment Aboard Merchant Vessels  
NVIC 9-00 Change 1 Carbon dioxide fire extinguishing system safety

## Fire Axe

### Items to check:

- At least one (1)
- Fire axe readily accessible.
- Located on the exterior of the vessel.

### Regulatory Cites:

46 CFR 142.227 Fire axe

## Fire-Detecting System

It is acceptable to install additional zones on the engine room detection system control panel to cover other areas where detection is not required by the regulations. A separate system is not needed for the protection of areas outside the engine room.

Non-Coast Guard approved detection equipment must be listed/approved by a nationally recognized testing laboratory such as UL or FM, and installed in accordance with the manufacturers approved design manual. The system may use heat detectors, smoke detectors, or a combination of the two. Optical flame detectors can also be used.

Engine room monitoring systems may be modified by a qualified technician to meet alarm or indication requirements.

HillerSAFE Fire and Bilge Flooding Alarm systems are not acceptable as an engine room fire-detection system aboard commercial towing vessels.

The system certifying entity must have experience in fire detection system design.

Only manufacturer approved system control panel(s) and remote indicator panel(s) such as a control panel repeater can be used on a required fire-detection system. Installation of any unapproved component(s) will void the system approval and certification.

Fire detection systems and equipment can be installed in other spaces as excess equipment. Existing fire detection systems and equipment designated by the owner/operator as excess are must be listed by an independent testing laboratory and is designed, installed, tested and maintained in accordance with the equipment manufacturer's recommendations and relevant NFPA standard(s).

### Items to check:

- As appropriate, an installed fire-detection system or an existing engine room monitoring system with fire-detection capability to detect engine room fires.
- If a fire-detection system is installed, the following components are approved under approval series 161.002 or listed by a NRTL:

- Detector(s)
- Control panel(s)
- Remote indicator panel(s)
- Fire alarm
- If an existing engine room monitoring system is installed, it uses detectors listed by a NRTL.
- For both fire-detection systems and existing engine room monitoring systems:
  - System is installed, tested, and maintained in accordance with the manufacturer's design manual
  - System is arranged and installed so a fire in the engine room automatically sets off alarms on:
    - A fire detection control panel at the primary operating station.
    - On a fire detection control panel or a remote indicator panel at any other operating station(s).
  - The control panel includes:
    - Power available light
    - Audible alarm
    - Visual zone indication to identify the location of the fire
    - Means to silence the audible alarm while maintaining visual alarms
    - Circuit-fault detector test-switch or internal supervision of circuit integrity
    - Function Identifying labels for all switches and indicator lights
- System draws power from two sources.
- System serves no other purpose, unless it is an engine room monitoring system.
- System certified by a registered professional engineer, a NICET level IV engineering technician or an authorized classification society.

#### **Regulatory Cites:**

46 CFR 136.110 Definitions

46 CFR 142.240 Inspection, testing, maintenance, and records

46 CFR 142.330 Fire-Detection System Equipment Requirements

29 CFR 1910.7 Definition and requirements for a nationally recognized testing laboratory

#### **Additional Guidance:**

Commandant (CG-ENG-4) Lifesaving and Fire Safety Division

Marine Safety Manual Volume II

NVIC 7-80 Use of Fire Detection Systems Which are Not Approved Under 46 CFR 161.002

NFPA 72 National Fire Alarm and Signaling Code

### **Firefighter's Outfit**

An improperly sized firefighter's outfit could be physically detrimental to the wearer and reduce a crew's ability to respond to emergencies. Firefighter's outfits are manufactured in various sizes and one size does not fit all. The vessels operating company and the master must consider the crew complement and the emergency duties assigned to each crewmember to ensure appropriately sized firefighter's outfits are carried on board the vessel at all times. This may require the company to provide a means to change out firefighter outfits when the crews compliment changes.

#### **Items to check:**

- Sufficient number of firefighters outfits.
- Firefighter's outfits meet NFPA 1971, Protective Ensemble for Structural Fire Fighting.
- Sufficient number of self-contained breathing apparatus (SCBAs)

- SCBAs are:
  - Approved by NIOSH, under 42 CFR part 84.
  - Have a minimum 30-minute air supply
  - Full facepiece
  - Pressure demand
  - Open circuit type

**Regulatory Cites:**

42 CFR Part 84 Approval of Respiratory Protective Devices  
 46 CFR 136.110 Definitions  
 46 CFR 142.226 Firefighter's outfit

**Additional Guidance:**

Commandant (CG-ENG-4) Lifesaving and Fire Safety Division  
 NVIC 6-01 Protective Equipment Required for Firefighter's Outfit

**Fire Hazard Minimized**

Small amounts of combustible and/or flammable liquids such as oil are likely to be present in the bilges of operating towing vessels. While small amounts of combustible and/or flammable liquids in the bilges due to normal operations is acceptable, any accumulation(s) of combustible and/or flammable liquids that present a fire hazard is not acceptable and must be removed. For further guidance see MSM Vol. II.

Likewise, accumulations of combustible and/or flammable materials (i.e. wood, paper, cardboard, oily rags, etc.) could present a fire hazard onboard the vessel and should be minimized. All excess combustible and/or flammable material which are not required for normal vessel operations should be removed from the vessel.

**Items to check:**

- Bilges and void spaces free from excess accumulation of combustible and flammable materials.
- Storage areas free from excess accumulation of combustible and flammable materials.

**Regulatory Cites:**

46 CFR 136.110 Definitions  
 46 CFR 140.665 Inspection and testing required when making alterations, repairs, or other such operations involving riveting, welding, burning or like fire-producing actions  
 46 CFR 142.220 Fire hazards to be minimized  
 46 CFR 143.220 Machinery space fire prevention

**Additional Guidance:**

Commandant (CG-ENG-4) Lifesaving and Fire Safety Division  
 Marine Safety Manual Volume II



## Fire Protection Training

The master of the vessel is required to conduct monthly firefighting drills and training. The drills are intended to familiarize the crew with the location and operation of all the fire protection equipment installed onboard the vessels and what their duties are in the event of a fire. Video training supplemented with a discussion may be used to instruct the crew, however, crew participation in actual drills is required on a monthly basis.

During drills, the master or other qualified trainer is expected to instruct the crew in the operation of all fire protection equipment installed onboard the vessel. For example, if a fixed fire extinguishing system is installed on board the vessel, the drills must show the crewmembers how to discharge the system by the remote controls and locally at the storage cylinders. The operation of any fire protection equipment, such as breathing apparatus, that is carried onboard the vessel should be included in regularly scheduled drills.

The location of the monthly fire drills should be varied to eventually cover all areas on the vessel. During these drills, the crew should evaluate equipment limitations or other problems that may be encountered during an actual fire in that location. The drills should also address potential problems from transporting differing cargoes, traveling differing routes, and incapacitation of key crewmembers.

### Items to check:

- Crewmembers participate in fire-fighting drills and receive instruction at least once each month.
- All crewmembers familiar with:
  - Fighting a fire in the engine room and elsewhere onboard the towing vessel:
    - Operation of all fire-extinguishing equipment.
    - How to stop any mechanical ventilation system for the engine room and effectively seal all natural openings to the space.
    - Operation of fuel shut-off(s) for the engine room.
  - Activating the general alarm.
  - How to report inoperative alarm systems and fire-detection systems.
  - Donning a firefighter's outfit and a self-contained breathing apparatus, if the vessel is so equipped.
- Records of fire-fighting drills and receive instruction recorded in the TVR, official logbook or in accordance the TSMS.

### Regulatory Cites:

[46 CFR 136.110](#) Definitions

[46 CFR 140.915](#) Items to be recorded

[46 CFR 142.245](#) Requirements for training crews to respond to fires

### Additional Guidance:

[Commandant \(CG-ENG-4\) Lifesaving and Fire Safety Division](#)

[Marine Safety Manual Volume II](#)

[NVIC 6-91](#) Fire Drills and On-Board Training

## Fire Pumps, Fire Mains, and Fire Hoses

If a fire main supplies water for services in addition to firefighting, pump performance criteria requirements must be met while simultaneously providing the additional water. If performance criteria of a fixed or portable fire pump(s) are suspect during an inspection or survey, see NVIC 6-72 for procedures to properly calculate fire pump capacities.

The term “self-priming” means the fire pump is able to create its own suction by priming itself independently without adding water to the pump casing or the suction hose. Portable self-priming pumps which have a manufacturer designed/installed device attached to the pump such as an exhaust primer or hand primer that requires the operator to pull the air out of the pump or suction hose are acceptable. Self-priming pumps that are not fitted with an exhaust primer or hand primer will typically have a water reservoir built into the casing that allows the pump to self-prime by recirculation of water within the pump when it is started. These pumps only have self-priming capability if the pump retains priming water from the previous pumping cycle within the reservoir. Self-priming pumps with a water reservoir that have been stored for a long period of time, or which are used in below-freezing weather, may not be able to self-prime if the reservoir is low on water or the reservoir water is frozen.

Objective evidence of an acceptable fire hose would be a hose that meets UL 19 or is constructed in accordance with NFPA 1961; however, fire hoses used to meet this section are not required to meet UL or NFPA standards. Other fire hoses can be considered on a case-by-case basis. Any lined commercial fire hose that meets size and length specifications and is in serviceable condition is acceptable. Acceptable “lined” hoses include single or double jacket woven cotton/polyester hose or rubber covered fire hose. Woven jacket fire hose has a single or double layer of outer woven fabric with an internal rubber lining. Rubber covered fire hose is constructed with the rubber covering integral with the weave. This hose appears homogeneous and does not have separate layers. Hose fittings should be brass or other suitable corrosion-resistant materials which comply with NFPA or standards otherwise acceptable to the cognizant OCMI. Further Guidance on fire hoses can be found in MSM Vol. II.

Objective evidence of an acceptable fire hose nozzle would be a nozzle that meets approval series 162.027 or ASTM F 1546; however, nozzles used to meet the requirements of this section are not required to meet those standards. Other nozzles can be considered on a case-by-case basis. Any nozzles made of corrosion-resistant material capable of providing a solid stream and a spray pattern is acceptable. Fire hose fittings and nozzles made of brass or bronze are acceptable for any service. Anodized aluminum fittings and nozzles should only be used for fresh water service.

#### **Items to check:**

- If equipped with a fixed fire pump:
  - The pump must be:
    - Power driven.
    - Self-priming.
    - Capable of delivering water simultaneously from the two highest hydrants or from both branches of the fitting if the highest hydrant has a Siamese fitting at:
      - Pitot-tube pressure of at least 50 psi.
      - Flow rate of at least 80 gpm.
  - Capable of being energized remotely and at the pump.
  - All suction valves necessary for the operation of the fire main in the open position or capable of operation from the same place where the remote fire pump control is located.
  - Isolation valves marked or color coded.
  - Sufficient number of fire hydrants to allow a stream of water to reach any part of the machinery space using a single length of fire hose.
  - Hose(s) attached to fire main.
- If equipped with a portable fire pump:
  - The pump must:
    - Power driven.
    - Self-priming.
    - Capable of delivering water of at the pump discharge at:
      - Discharge gauge pressure of at least 60 psi.
      - Flow rate of at least 80 gpm.

- Sufficient amount of fire hose to so that a stream of water will reach any part of the vessel
- Fire hose(s) immediately available to attach to the fire pump.
- Pump stowed with its hose(s) and nozzle(s) outside of the machinery space.
- Fire hoses are:
  - Lined commercial fire hose(s)
  - 50 feet in length
  - At least 1.5 inches in diameter
- Fire nozzle(s) are:
  - Made of corrosion-resistant material
  - Capable of providing a solid stream and a spray pattern.

**Regulatory Cites:**

46 CFR 136.110 Definitions  
 46 CFR 142.240 Inspection, testing, maintenance, and records  
 46 CFR 142.325 Fire pumps, fire mains, and fire hoses  
 46 CFR 143.250 System Isolation and marking

**Additional Guidance:**

Commandant (CG-ENG-4) Lifesaving and Fire Safety Division  
 Equivalency Determination – Fire Pumps for Subchapter C and Subchapter M Towing Vessels  
 Marine Safety Manual Volume II  
 NVIC 6-72 Guide to Fixed Fire-Fighting Equipment Aboard Merchant Vessels

**Hand-Portable Fire Extinguishers**

The extinguishers required by 46 CFR Table 142.230(a) and (b) should be dispersed throughout the vessel outside the engine room so they are readily available to the crew during an emergency.

Towing vessels greater than 65 feet in length are also required to carry additional 40-B hand portable extinguishers based on the vessels brake horsepower – one per 1000 BHP up to a maximum of six. These extinguishers should be dispersed throughout the engine room.

46 CFR 142.231(a) allows the OCMI to permit existing towing vessels to continue to utilize previously installed fire extinguishers with extinguishing capacities smaller than what is required so long as they are maintained in good condition to the satisfaction of the OCMI. All new equipment and installations must meet the applicable requirements for new vessels.

Some vessels carry K-rated extinguishers in the galley to protect against deep fat fryer fires. These extinguishers may be carried as excess equipment.

Towing vessels can carry fire extinguishers above the minimum carriage requirements as excess equipment provided the equipment meets the same approval standards as those outlined for the required equipment and the equipment is maintained in good and serviceable condition.

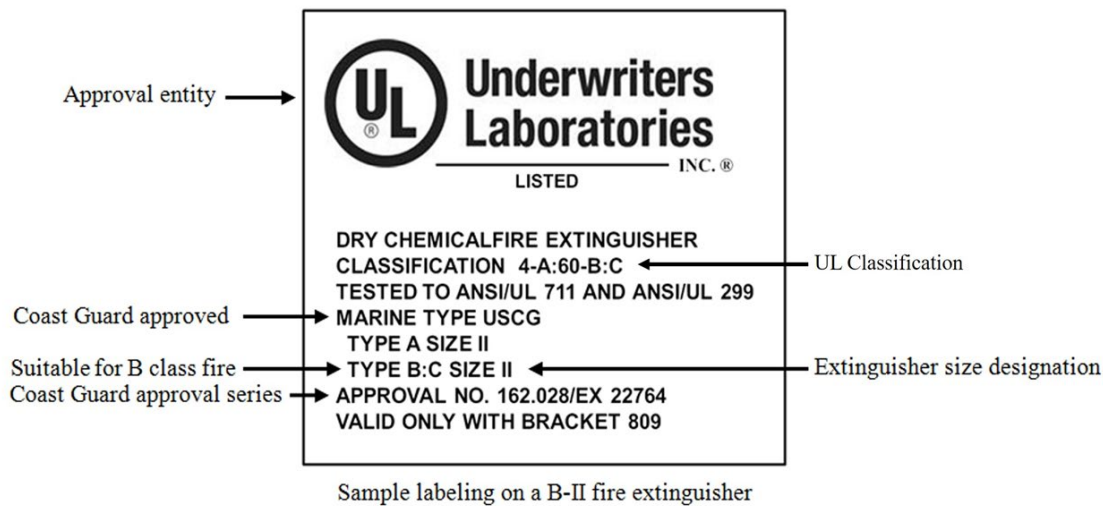

A non-approved bracket must be designed and function the same as an approved bracket and professionally manufactured. “J” hooks are not acceptable.

**Items to check:**

- Sufficient number of hand-portable fire extinguishers.
- Proper type – suitable for class B fires.
- Proper size for the vessel.
- Coast Guard/UL approved under approval series 46 CFR 162.028.
- Conspicuously located. If in a location where visual obstructions cannot be avoided, there is means to indicate the extinguisher location – i.e. signage.
- Readably accessible and immediately available.
- Secured in an approved bracket or suitably secured to prevent chaffing or dismounting.
- Tamper seal properly attached to the operating mechanism pull pin or locking device. In serviceable condition.
- Hydrostatically tested.
- Inspected annually by a qualified person.
- Records of inspections and tests recorded in the TVR, official logbook, in accordance the TSMS or on a tag attached to each unit.
- Records contain the following information:
  - Dates when inspections and tests were performed.
  - The number and any other identification of each unit inspected and tested.
  - Results of the inspections and tests.
  - The name of the person(s) who conducted the inspections and tests.
- Receipts and other records generated by inspections and tests retained for at least 1 year.

**Regulatory Cites:**

- 46 CFR 136.110 Definitions
- 46 CFR 142.215 Approved equipment
- 46 CFR 142.230 Hand-portable fire extinguishers and semi-portable fire-extinguishing systems

46 CFR 142.231 Exception for portable and semi-portable fire extinguishers required for existing vessels  
46 CFR 142.240 Inspection, testing, maintenance, and records

**Additional Guidance:**

Commandant (CG-ENG-4) Lifesaving and Fire Safety Division  
Marine Safety Manual Volume II  
CG-CVC Policy Letter 18-04 - Guidance On Implementation Of New Standards For Fire Protection,  
Detection, And Extinguishing Equipment  
NVIC 13-86 Use of Underwriters Laboratories (UL) Listed Fire Extinguishers  
NFPA 10 Standard for Portable Fire Extinguishers

## Heat Detection

A heat-detection system with restorable heat-sensing detectors to detect fires in the galley.

Restorable heat-sensing detectors means the detectors automatically reset when the heat source is removed.

Galley heat detection can be provided by an approved standalone detection system or it can be incorporated into the engine room fire detection system as a separate zone.

**Items to check:**

- Heat-detection system in galley.
- System has one or more restorable heat-sensing detectors to detect fires in the galley.
- System sounds an audible alarm at each operating station.

**Regulatory Cites:**

46 CFR 136.110 Definitions  
46 CFR 142.240 Inspection, testing, maintenance, and records  
46 CFR 142.330 Fire-Detection System Equipment Requirements  
29 CFR 1910.7 Definition and requirements for a nationally recognized testing laboratory

**Additional Guidance:**

Commandant (CG-ENG-4) Lifesaving and Fire Safety Division  
Marine Safety Manual Volume II

## Machinery Space Fire Protection

Oily mixtures/residues are commonly seen in a vessel's bilge. Determining if the amount is "excessive" is on a case-by-case basis.

IAW 33 CFR 155.330 and 155.350 oily mixtures/residues are permitted to be stored in a vessel's bilge; however, IAW 46 CFR 155.770 no oil or hazardous material can intentionally be drained into the vessel's bilge from any source.

**Items to check:**

- Seals and gaskets properly maintained to prevent leaks of combustible or flammable liquids.

- Piping and machinery components that exceed 220° C (428°) F properly insulated and protected against contact with flammable or combustible fluids.
- Flammable and combustible products not stored in machinery space.
- Flammable and combustible products stored in a suitable container if located in any machinery space.

**Regulatory Cites:**

46 CFR 30.10 Definitions (combustible and flammable liquids)  
 46 CFR 136.110 Definitions  
 46 CFR 143.220 Machinery space fire protection

**Additional Guidance:**

Commandant (CG-ENG-4) Lifesaving and Fire Safety Division  
 Marine Safety Manual Volume II

**Safety Orientation**

Crewmembers who have not participated in the required monthly drills must undergo a safety orientation within 24 hours of reporting on board. This orientation must include a review of basic fire response procedures, the crewmembers duties during an emergency, how to operate the fire protection equipment installed on the vessel and instruction on how to operate the fuel shutoffs and ventilation controls.

**Items to check:**

- Crewmembers safety orientation includes:
  - Fighting a fire in the engine room and elsewhere onboard the towing vessel:
    - Operation of all fire-extinguishing equipment.
    - How to stop any mechanical ventilation system for the engine room and effectively seal all natural openings to the space.
    - Operation of fuel shut-off(s) for the engine room.
  - Activating the general alarm.
  - How to report inoperative alarm systems and fire-detection systems.
  - Donning a firefighter's outfit and a self-contained breathing apparatus, if the vessel is so equipped.
- Records of safety orientations recorded in the TVR, official logbook or in accordance the TSMS.

**Regulatory Cites:**

46 CFR 136.110 Definitions  
 46 CFR 140.915 Items to be recorded  
 46 CFR 142.245 Requirements for training crews to respond to fires

**Additional Guidance:**

Commandant (CG-ENG-4) Lifesaving and Fire Safety Division  
 Marine Safety Manual Volume II  
 NVIC 6-91 Fire Drills and On-Board Training

## Smoke Detection

A means to detect smoke in berthing areas and lounges that alerts individuals in those spaces.

### Items to check:

- Smoke detection provided in berthing spaces.
- Smoke detection provided in lounges.
- Smoke detection accomplished by either:
  - An installed detection system
  - Individual battery-operated detectors meeting UL 217
- Detection systems or individual detectors operational.

### Regulatory Cites:

[46 CFR 136.110](#) Definitions

[46 CFR 142.240](#) Inspection, testing, maintenance, and records

[46 CFR 142.330](#) Fire-Detection System Equipment Requirements

### Additional Guidance:

[Commandant \(CG-ENG-4\) Lifesaving and Fire Safety Division](#)

[Marine Safety Manual Volume II](#)

[NFPA 72 National Fire Alarm and Signaling Code](#)

## SOLAS Chapter II-2 Compliant Vessel

Towing vessels that operate on international/foreign voyages may be subject to increased fire protection requirements and require issuance of SOLAS certificates in order to engage in foreign trade. Failure to properly maintain and/or have on board any fire protection equipment required by an international certificate, regardless of the vessels compliance with 46 CFR Part 142, will invalidate the international certificate(s).

### Regulatory Cites:

[46 CFR 136.110](#) Definitions

[46 CFR 142.205](#) Alternative standards

## Storage of Flammables and Combustibles

Combustible and/or flammable products include items commonly considered to be combustible or flammable and items that are specifically labeled as combustible or flammable - i.e. on the product label, on the Material Safety Data Sheet (MSDS), etc.

A combustible and/or flammable products storage room can be any room or compartment on the vessel if the area is free of ignition sources. To be considered free of ignition sources procedures should be in place to ensure no ignition sources such as hot work, open flames or smoking are introduced into the space. Electrical and machinery installations in these spaces should be kept to a minimum. Possible ignition sources within the space such as wiring, lighting, electrical outlets, electrical motors, etc. should employ suitable protection techniques - i.e. spark ignition proof, explosion-proof, intrinsically safe, etc.

The 40-B:C portable fire extinguisher required to be located near the storage area or cabinet is in addition to the portable fire extinguishers required by Tables 142.230(d)(1) and 142.230(d)(2) of this part. In lieu

of the additional 40-B:C portable fire extinguisher, use of an approved semi-portable or approved/appropriately sized fixed fire-extinguishing system is acceptable for the storage area, cabinet.

Other hazardous ships stores need to be stored in accordance with 46 CFR Part 147 (Subchapter N) which is applicable to towing vessels subject to inspection.

**Items to check:**

- Flammable or combustible products stored in a designated storage room or cabinet.
- If a storage room is provided, free of ignition sources.
- If a dedicated storage cabinet is provided, secured to the vessel so that it does not move and is:
  - A flammable liquid storage cabinet that satisfies UL 1275; or
  - A flammable liquid storage cabinet that satisfies FM Approvals Standard 6050; or
  - A suitable steel container that provides an equivalent level of protection.
- A 40-B:C portable fire extinguisher located near the storage room or cabinet.

**Regulatory Cites:**

46 CFR 136.110 Definitions

46 CFR 142.220 Fire hazards to be minimized

46 CFR 142.225 Storage of flammable or combustible products

**Additional Guidance:**

Commandant (CG-ENG-4) Lifesaving and Fire Safety Division

Marine Safety Manual Volume II

NVIC 2-89 Guidance for Electrical Installations on Merchant Vessels and Mobile Offshore Drilling Units

NFPA 70 National Electric Code.



## International Requirements

Towing vessels that engage in international (foreign) voyages must be in compliance with all applicable international requirements. Determining applicability of international requirements can be a complex and confusing process. Each vessel is evaluated on a case by case basis taking into account the vessels build date, the application of the proper tonnage system and when the provisions of the international conventions became effective. Key to making certificate and equipment carriage determinations is being able to apply the proper tonnage system to the vessel. The Coast Guards primary document to determine the applicability of tonnage measurement systems to a vessel is NVIC 11-93 Ch-3.

Vessels built on or after July 18, 1994, must comply with ALL international requirements using their GT ITC and should have a complete suite of international certificates to engage in foreign voyages.

Vessels built before July 18, 1994 can use their GRT for many international requirements, but they must comply with certain international requirements using their GT ITC:

A vessel built before 18JUL1994 can use GRT for:

- GMDSS
- MARPOL (currently all annexes except Annex VI)
- SOLAS (with the exception of ISM and ISPS)
- Safe Manning Document.

A vessel built before 18JUL1994 must use GT ITC for:

- LRIT
- ISM
- ISPS
- MARPOL Annex VI
- STCW

There have been instances of foreign governments requiring certain certificates/documents to be onboard U.S. flagged vessels while in their ports even when those certificates/documents are not required by an international convention – i.e Safe Manning Documents (SMD) and International Ship Security Certificates (ISSC). To facilitate the operation of the U.S. maritime industry, upon request, the CG can issue international certificates to a U.S. flag vessel even when an international convention does not apply to the vessel. Owners and operators of towing vessels that engaged on international (foreign) voyages should be encouraged to take advantage of this opportunity to avoid delays while conducting business in a foreign port.

### Items to check:

- All applicable certificates current and valid.
- Vessel meets carriage requirements of certificates.
- All required equipment is properly maintained, in serviceable condition and ready for immediate use.

### Additional Guidance:

[NVIC 11-93 Ch-3](#) Applicability of Tonnage Measurement Systems to U.S. Flag Vessels  
[CVC-WI-004](#) U.S. Flag Interpretations on ISM Code

## General International Compliance

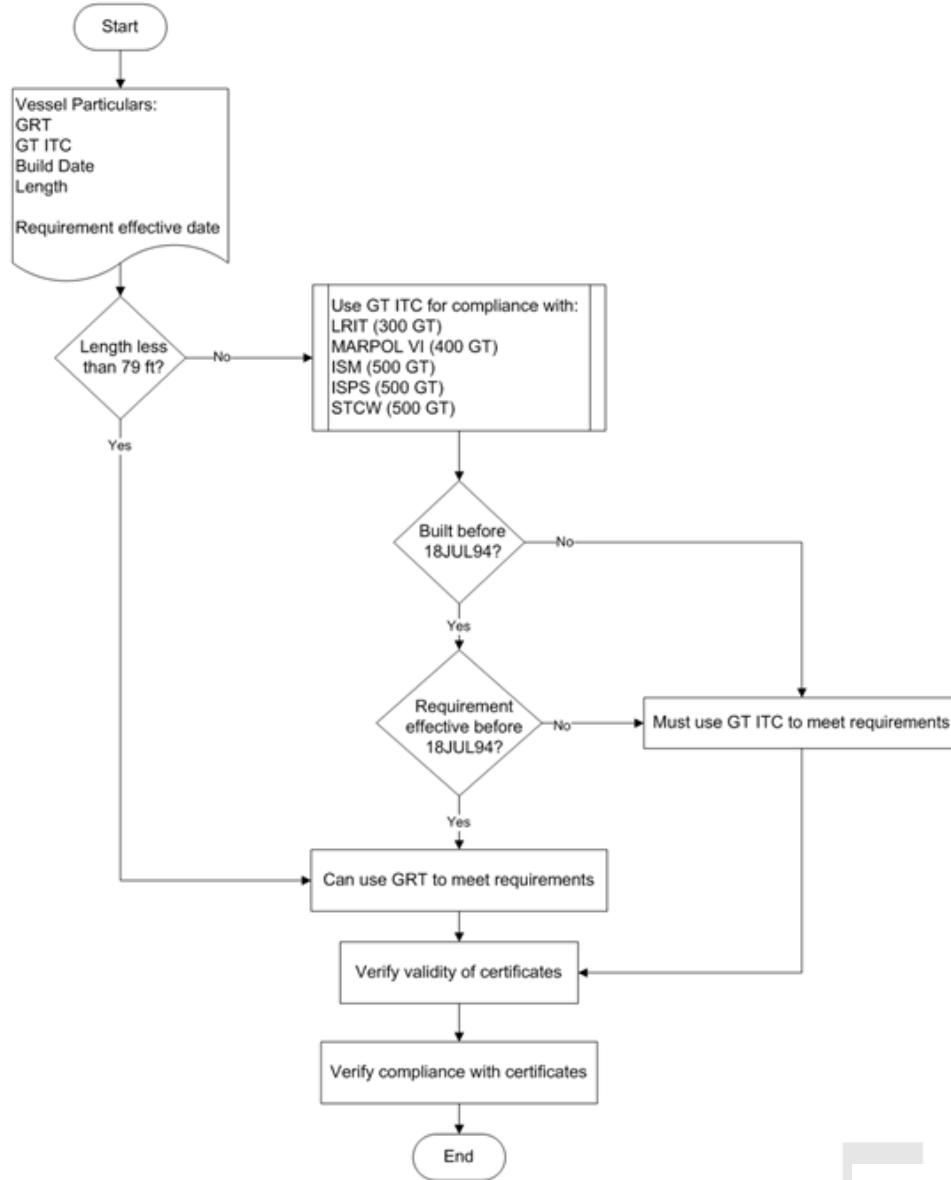

## Inspections and Surveys for Certification

### Annual Inspection Fees

46 CFR 2.10-20 requires a vessel owner to pay an annual inspection fee before inspection or examination services are provided. Annual inspection fees are listed in 46 CFR Table 2.10-101. Failure to pay the required fees can result in vessel inspection delays and/or penalties as outlined in 46 CFR 2.10-135.

#### Items to check:

- Annual inspection fees paid
- Delinquent inspection fees, if any, paid.

#### Regulatory Cites:

[46 CFR 2.10-20](#) General requirements

[46 CFR Table 2.10-101](#) Annual Vessel Inspection Fees for U.S. and Foreign Vessels Requiring a Certificate of Inspection

[46 CFR 2.10-135](#) Penalties

### Annual inspections for Coast Guard Inspection Option

#### Items to check:

- Annual inspections completed within three (3) months of the COI anniversary date.
- Inspection completed by cognizant OCMI.
- Coast Guard Endorsement on current COI after satisfactory Annual Inspection, or CG-835 retained for correction of deficiencies.

#### Regulatory Cite:

[46 CFR 137.200](#) Documenting Compliance for the Coast Guard Inspection Option

### Annual surveys for TSMS External Survey Program

#### Items to check:

- Annual survey completed within three (3) months before or after the COI anniversary date.
- Surveys completed by Surveyor from a TPO.
- TSMS procedures followed for survey.
- Conduct of survey follows 46 CFR 137.215.
- Applicable TSMS sections available to Surveyor.
- TPO issued a survey report as required by 46 CFR 137.205(b).

#### Regulatory Cites:

[46 CFR 137.202](#) Documenting compliance for the TSMS inspection option

[46 CFR 137.205](#) External survey program

46 CFR 137.215 General conduct of survey  
46 CFR 137.220 Scope

## Annual surveys for TSMS Internal Survey Program

### Items to check:

- Annual survey conducted as one event or scheduled so that each required item is surveyed with successive surveys not exceeding one (1) year on an individual item.
- Company issued a report that meets requirements in 46 CFR 137.135.
- TSMS includes:
  - Procedures for survey and testing that follow 46 CFR 137.215.
  - Equipment, systems and onboard procedures to be surveyed.
  - Identification of items that would keep the vessel out of service; deficiencies, non-conformities, survey deficiencies, corrective action reports.
  - Procedures for documenting and reporting non-conformities and deficiencies.
  - Procedures for reporting and correcting major non-conformities.
  - Responsible person in management who can:
    - Stop vessel operations pending correction of non-conformities and deficiencies.
    - Oversee compliance activities.
    - Track and verify that non-conformities and deficiencies were corrected.
  - Procedures for recordkeeping.
  - Procedures for assigning competent personnel as surveyors.

### Regulatory Cites:

46 CFR 137.135 Reports and documentation required for the TSMS option.  
46 CFR 137.202 Documenting compliance for the TSMS inspection option  
46 CFR 137.210 Internal survey program  
46 CFR 137.215 General conduct of survey  
46 CFR 137.220 Scope

## Approved Equipment

Certain types of equipment are required to be approved by the Coast Guard to meet specific standards. Typically lifesaving and fire protection equipment fall under this category. If a piece of equipment is "Coast Guard Approved" it will list its approval series, typically a six digit number. A searchable list of Coast Guard Approved equipment and approval series can be accessed through the Coast Guard Maritime Information Exchange, [USCG Approved Equipment Listing Database \(EQList\)](#).

### Items to check:

- Lifesaving equipment Coast Guard approved.
- Portable extinguishers, semi-portable fire extinguishers and fixed fire extinguishing systems Coast Guard approved.

### Regulatory Cites:

46 CFR 136.110 Definitions: "Approval Series" and "Fixed fire-extinguishing system"  
46 CFR 136.175 Approved Equipment  
46 CFR 141.200 Approved Equipment "Lifesaving"  
46 CFR 142.215 Approved Equipment "Firefighting"

## Certificate of Inspection

### Items to Check:

- Valid COI on board vessel.
- Vessel in compliance with terms of the COI.
- Original COI on board and properly posted or, if posting is impracticable, properly stored and readily available.

### Regulatory Cites:

[46 CFR 136.200](#) Certificate Required  
[46 CFR 136.220](#) Posting  
[46 CFR 136.230](#) Routes Permitted  
[46 CFR 140.205](#) General Vessel Operation

## Inspection for Certification

When submitting an application for inspection, the owner or managing operator will need to specify which inspection option (TSMS or Coast Guard) will be implemented on the vessel.

### Items to check:

- Please see CVC WI-013 Towing Vessel COI Inspection under TSMS Option for amplifying information when submitting a COI application for TSMS Option.
- Schedule Inspection for Initial Certification with cognizant OCMI at least 3 months (90 days) before inspection for certification.
- Submit Form CG-3752 "Application for inspection of U.S. Vessel" at least 30 days prior to inspection for certification.
- For Initial Certification:
  - Vessel Particular Information.
  - Number of Persons in addition to crew.
- For Renewals:
  - Any changes to the information provided on the previous CG-3752 (application for inspection).
  - A description of any modifications to the vessel.

### Regulatory Cite:

[46 CFR 136.130](#) Options for documenting compliance to obtain a Certificate of Inspection  
[46 CFR 136.210](#) Obtaining or renewing a COI

### Additional Guidance:

[CG-CVC Policy Letter 20-01](#) - Subchapter M Enforcement Posture for Certificate of Inspection Phase-In Requirements

[CVC Work Instruction WI-013](#) - Towing Vessel COI Inspection under TSMS Option

[CVC Work Instruction WI 015](#) - Determinations for a Vessel's Keel Laid Date or Similar Stage of Construction

[CVC Work Instruction WI 018](#) - Laid up Inspected/Examined Vessels

## Intervals for drydock, underwater survey in lieu of drydocking (UWILD) and internal structural examinations (ISE)

Regardless of the option chosen to obtain a COI, upon obtaining the initial COI each towing vessel must conduct drydock and Internal structural examinations (ISE) at the appropriate interval based on Fresh or Saltwater Service:

- For freshwater service (exposed to saltwater less than 6 months in any 12-month period since last examination) at least once every 5 years.
- For saltwater service (exposed to saltwater more than 6 months in any 12-month period since last examination) at least twice every 5 years, with not more than 36 months between examinations.

As an alternative, a towing vessel can comply with drydock and ISE requirements by:

- Maintaining a valid load line certificate – see 46 CFR 137.320; or,
- Maintaining class by ABS or another recognized classification society accepted by the Coast Guard – see 46 CFR 137.322.

***Note:** In instances where a vessel is required to conduct two drydocks and ISEs for salt water service, the allowance to accept load line or class drydock and ISEs only counts for one of the required two examinations.*

U.S. vessel owners and operators desiring to utilize an underwater survey in lieu of drydocking (UWILD) should review the guidance in NVIC 1-89, Underwater Survey Guidance. UWILD is an optional compliance option and, if utilized, permits the owner to alternate drydocks with underwater surveys. For instance, a vessel in salt water service that would normally be drydocked at years 2.5, 5, 7.5, 10, 12.5, and 15 could conduct these alternate underwater surveys instead of drydocking at years 2.5, 7.5, and 12.5.

### Items to check:

- Valid Load Line Certificate.  
OR
- Vessel maintains class and meets RCS rules on drydocking and ISE requirements.  
OR
- Complete drydock (or Coast Guard approved UWILD) and ISE at the correct interval:
  - Salt-Water: Twice every five (5) years, with not more than thirty six (36) months between examinations.
  - Fresh-Water: At least once every five (5) years.

### Regulatory Cites:

[46 CFR 137.300](#) Intervals for drydock and internal structural examinations

[46 CFR 137.320](#) Vessels holding a valid load line certificate

[46 CFR 137.322](#) Classed Vessels

[46 CFR 137.335](#) Underwater survey in lieu of drydocking

### Additional Guidance:

[NVIC 1-89](#), Underwater Survey Guidance

[CVC WI-029](#) - Drydock Exams, Underwater Survey in Lieu of Drydocking and Drydock Extension Policy Clarifications

## TSMS Compliance

### Items to check:

- Additional documentation submitted with Form CG-3752 “Application for inspection of U.S. Vessel”:
  - Valid TSMS Certificate.
  - Report of a Survey, per 46 CFR 137.215 that vessel complies with Sub-M.
  - Objective Evidence that operator and vessels are in compliance with TSMS.
  - Objective Evidence of External or Internal survey program.
  - Objective Evidence that vessel has undergone drydock and internal structural examination.
- Copy of valid TSMS certificate on board vessel.
- External vessel audit conducted prior to issuance of initial COI for vessels operated for six (6) months or more by owner or managing operator.
- External vessel audit conducted no later than six (6) months after issuance of initial COI for vessels operated for six(6) months or less prior to receiving the initial COI.
- External vessel audit conducted at least once during the five (5) year period of validity of the TSMS certificate.
- Results of external vessel audits submitted to cognizant OCMI within 30 days of completion.

### Regulatory Cites:

46 CFR 136.210 Obtaining or renewing a COI  
46 CFR 137.202 Documenting compliance for the TSMS option  
46 CFR 137.305 Documenting compliance for the TSMS option  
46 CFR 138.305 TSMS Certificate  
46 CFR 138.315 External audits for TSMS certificate  
46 CFR 138.505 Submittal of External Audit Results

### Additional Guidance:

CG-CVC Policy Letter 17-03 Certificate of Inspection (COI) Phase-In Period for Existing Towing Vessels Using the TSMS Option Under 46, Code of Federal Regulation (CFR) Subchapter M

# Lifesaving

## Introduction

Lifesaving systems are considered essential systems – see [46 CFR 136.110](#). All deficiencies related to lifesaving requirements will, in most cases, have to be resolved prior to the vessel getting underway or issuing/endorsing the Certificate of Inspection (COI). All lifesaving equipment or arrangement details not covered within 46 CFR Part 141 must be to the satisfaction of the approved third-party organization (TPO) that issued the Towing Safety Management System (TSMS) Certificate and/or the cognizant Officer in Charge, Marine Inspection (OCMI), as appropriate.

Lifesaving equipment and systems are very important in the protection of the vessel's occupants so they need to be properly maintained and immediately available to provide protection if and when needed. Inspections and vessel surveys will verify lifesaving equipment and installations readiness and compliance with Subchapter M, the TSMS, Subchapter W and SOLAS as applicable.

In addition to the master of the vessel, proper installation and maintenance of lifesaving equipment is also the responsibility of the owner and/or managing operator. Improperly installed lifesaving equipment, equipment that has not been maintained and/or expired equipment would not be considered ready for use.

The below flowchart provides a visual high-level representation of the towing vessel lifesaving equipment requirements. It should not be used as a standalone tool for determining vessel compliance.

### Notes:

1. The carriage requirements listed are for domestic routes.
2. During an inspection for certification the vessel must be equipped for the highest route authorized on the COI.
3. Carriage requirements will need to be adjusted if specialized or additional equipment has been required by the OCMI.



# General Lifesaving Equipment Requirements

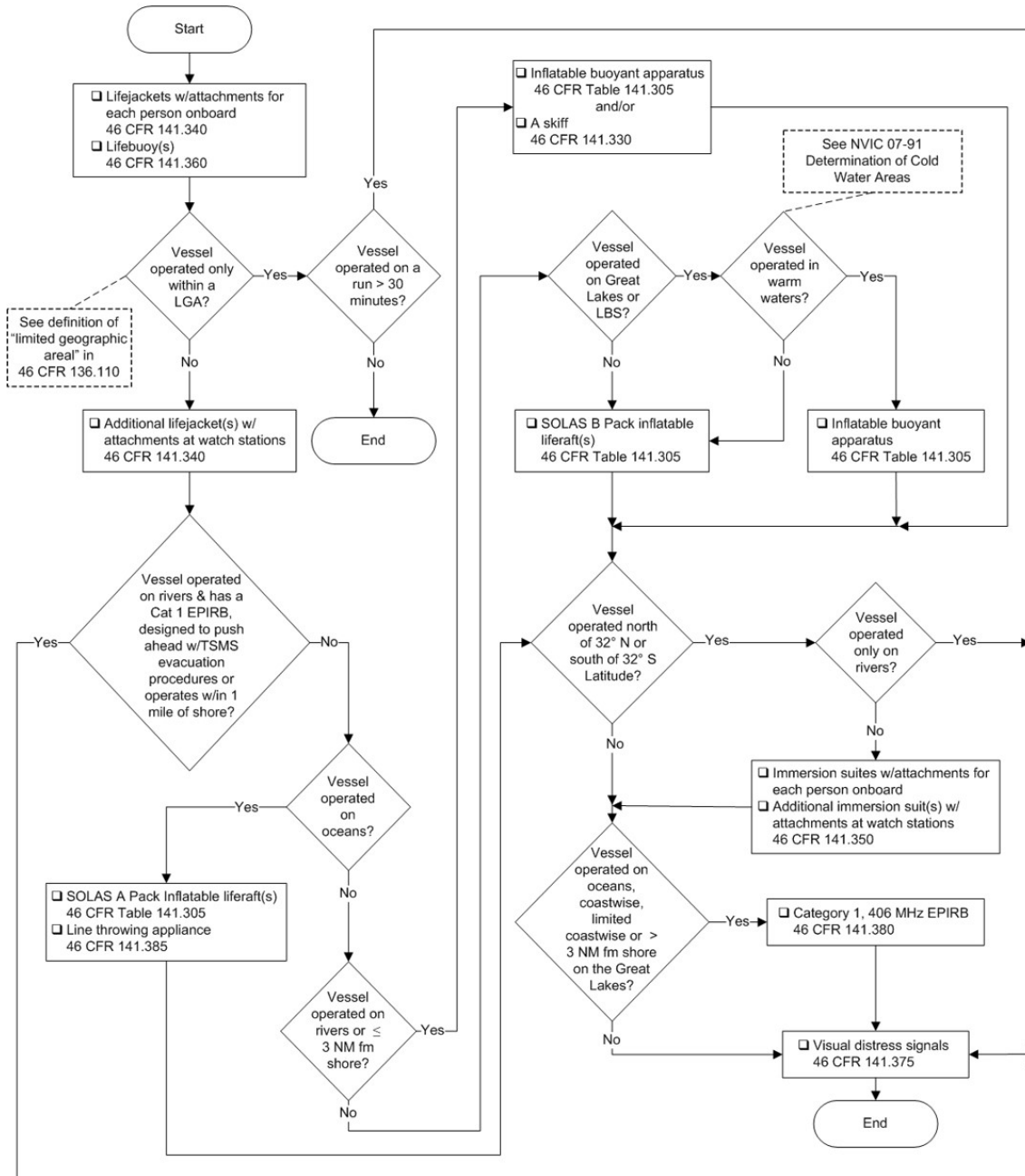

## Crew Lifesaving Training Requirements

46 CFR Part 140 lists minimum lifesaving training requirements. The lifesaving portion of an inspection or survey is not complete until both the physical lifesaving equipment or system is inspected and the competency of the crew is evaluated. Drills can be used by the inspector/TPO to evaluate crew competency. By observing lifesaving drills, the inspector/TPO can gauge whether or not the master and crew are familiar with the vessel and its lifesaving equipment and possess the skills necessary to deal with an emergency.

### Regulatory Cites:

46 CFR 141.240 Requirements for training crews.

## Emergency Position Indicating Radio Beacon (EPIRB)

Category 1 EPIRBs are designed to float-free and activate automatically. A manually activated Category 2 406 MHz EPIRB is not an acceptable substitute on a vessel required by this part to carry a Category 1 EPIRB.

EPIRBs have proven their effectiveness in saving lives by providing an additional means to quickly locate a vessel and/or the crew during an emergency. Towing vessels that are not required by this part to carry an EPIRB may carry a Category 1 or Category 2 406 MHz EPIRB as excess equipment provided the EPIRB is maintained in good and serviceable condition and is registered with NOAA.

Except for an EPIRB installed in inflatable survival craft that is tested during the annual servicing of the survival craft, the EPIRB is required to be tested immediately after installation and at least once each month thereafter. The test must be conducted in accordance with the manufacturer's instructions. If the EPIRB is not operating, it must be repaired or replaced with an operating EPIRB prior to the vessel getting underway.

The EPIRB battery must be replaced immediately after the EPIRB is used (except for testing) and before the battery's expiration date.

### Items to check:

- EPIRB is a Category 1 406 MHz.
- EPIRB has been tested and test results were satisfactory.
- EPIRB marked with the vessel's name.
- EPIRB properly stowed in a float-free arrangement.
- If the EPIRB uses a hydrostatic release, hydrostatic release not expired.
- EPIRB battery not expired.
- Valid EPIRB registration.

### Regulatory Cites:

46 CFR 141.230 Readiness

46 CFR 141.235 Inspection, testing, and maintenance

46 CFR 141.380 Emergency position indicating radio beacon (EPIRB)

46 CFR 199.190 Operational readiness, maintenance, and inspection of lifesaving equipment

47 CFR 80.1061 Special requirements for 406.0-406.1 MHz EPIRB stations

47 CFR 80.1085 Ship radio equipment—General

### **Additional Guidance:**

Commandant (CG-ENG-4) Lifesaving and Fire Safety Division  
Marine Safety Manual Volume II

## **Immersion Suits**

Based upon the vessel arrangement and to facilitate immediate accessibility to immersion suit(s) at normally manned spaces such as work station(s), watch station(s) or work site(s), the OCMI/TPO has the discretion to require additional immersion suits. If additional immersion suits are required, the number of additional suits for the space should equal the number of persons normally on watch or working in the space.

The total number of immersion suits should not be lower than the total persons allowed to be carried by the COI plus any additional suits required by the OCMI.

Whistle do not have an approval series; however, MSM Vol. II contains guidance on acceptable whistles.

### **Items to check:**

- Sufficient number of appropriately sized immersion suits.
- All immersion suits Coast Guard approved under approval series [46 CFR 160.171](#)
- Immersion suits properly stowed and readily accessible.
- Immersion suit stowage location(s) properly marked.
- Immersion suits properly marked with the vessel or persons name.
- Immersion suits properly fitted with retro-reflective material.
- Immersion suits fitted with an approved and serviceable lifejacket light.
- Immersion suits fitted with a serviceable whistle.
- Immersion suits in sound (serviceable) material condition – free of defects and/or unauthorized repairs.

### **Regulatory Cites:**

[46 CFR 141.230](#) Readiness  
[46 CFR 141.235](#) Inspection, testing, and maintenance  
[46 CFR 141.350](#) Immersion suits  
[46 CFR 161.012](#) Personal Flotation Device Lights  
[46 CFR 164.018](#) Retroreflective Material for Lifesaving Equipment  
[46 CFR 199.70](#) Personal lifesaving appliances

### **Additional Guidance:**

Commandant (CG-ENG-4) Lifesaving and Fire Safety Division  
Marine Safety Manual Volume II  
NVIC 01-08 Shipboard Inspection and Testing of Immersion Suits  
NVIC 03-10 New SOLAS Requirements for Lifejackets and Immersion Suits Effective 1 JULY 2010

## Line Throwing Appliance

Towing vessels can carry line throwing appliance(s) above the minimum carriage requirements as excess equipment provided the equipment meets the same approval standards as those outlined for the required equipment and the equipment is maintained in good and serviceable condition.

### Items to check:

- Line throwing appliance Coast Guard approved under approval series [46 CFR 160.040](#).
- Line throwing appliance readily accessible.
- All equipment listed on the manufacturer's equipment list/instruction placard packed with the line throwing appliance.
- An appropriate (length, breaking strength and color) auxiliary line provided.

### Regulatory Cites:

[46 CFR 141.230](#) Readiness  
[46 CFR 141.235](#) Inspection, testing, and maintenance  
[46 CFR 141.385](#) Line throwing appliance

### Additional Guidance:

[Commandant \(CG-ENG-4\) Lifesaving and Fire Safety Division](#)  
[Marine Safety Manual Volume II](#)

## Lifebuoy

The minimum number required, the minimum size required, attachments required and stowage location requirements are based on the length of the vessel. The cognizant OCMI can require additional lifebuoys as deemed necessary based on the vessels operating area.

Length (Feet)	Lifebuoy Size (inches)	Number required
=< 26	20	1
>26 to <79	24	2
=>79	24	4

In accordance with [46 CFR 141.360\(b\)\(1\)](#) the lifebuoy must be approved under approval series [160.050](#) or [160.150](#). There is no specific regulatory requirement for a lifebuoy approved under approval series [160.050](#) to have retro-reflective material; however, a lifebuoy approved under approval series [160.150](#) must be fitted with approved retro-reflective material in accordance with [46 CFR 160.150-3\(f\)](#). Towing vessels on international routes must ensure retro-reflective material is fitted in accordance with [IMO Resolution A.658\(16\)](#). When retro-reflective material is required, the lifebuoy must be fitted with approved

retro-reflective material (tape) with a minimum of 5 cm (2 inches) width around the lifebuoy at four locations spaced equally around the circumference of the lifebuoy.

Detectability is a key component in minimizing the time it takes to rescue a person once they enter the water. International orange lifebuoys are preferred because they are more visible in white caps and glare; however, lifebuoys can be white or international orange in color unless the vessel is on an ocean, coastwise or international voyage. A vessel on an ocean, coastwise or international voyage must carry lifebuoys that are international orange in color. Lifebuoys with properly fitted and serviceable lights and/or smoke signals further enhances the likelihood that a person in the water will be located quickly for a prompt rescue in all operating areas and conditions.

If a towing vessel only carries one lifebuoy with attached floating electric water light, the water light must not be permanently attached to the lifebuoy. The water light should be attached by a lanyard and corrosion-resistant clip as required by this section to allow the water light to be quickly disconnected.

A vessel greater than 79 feet in length must have a lifebuoy located on each side of the primary operating station.

#### **Items to check:**

- Sufficient number of lifebuoys.
- Lifebuoys Coast Guard approved under approval series [46 CFR 160.050](#) or [160.150](#).
- Lifebuoys the proper color.
- Lifebuoys properly stowed.
- Lifebuoys properly marked with the vessel name.
- Lifebuoys properly fitted with retro-reflective material.
- Proper number of lifebuoys fitted with approved water lights and lanyards.
- Proper number of lifebuoys fitted with buoyant life-line(s).
- Lifebuoy in sound (serviceable) material condition – free of defects and/or unauthorized repairs.

#### **Regulatory Cites:**

[46 CFR 141.230](#) Readiness

[46 CFR 141.235](#) Inspection, testing, and maintenance

[46 CFR 141.360](#) Lifebuoys

[46 CFR 161.010](#) or [161.110](#) Floating Electric Waterlight

[46 CFR 164.018](#) Retroreflective Material for Lifesaving Equipment

#### **Additional Guidance:**

[Commandant \(CG-ENG-4\) Lifesaving and Fire Safety Division](#)

[Marine Safety Manual Volume II](#)

[IMO Resolution A.658 \(16\) Use and Fitting of Retroreflective material on lifesaving appliances](#)

[NVIC 02-63 Guide for Inspection and Repair of lifesaving Equipment](#)

## **Lifejackets**

Some lifejacket and lifejacket stowage requirements are found in International Maritime Organization (IMO) standards that have been incorporated by reference (IBR). This means all applicable parts of the IMO resolutions have the full force of regulation.

Work vests are considered safety equipment not lifesaving equipment and are not authorized, or an appropriate substitution for a lifejacket(s). Work vests must be stowed in locations separately from

lifejackets. The stowage location(s) for work vest and the stowage location(s) for approved lifejackets need to be such as not to be easily confused.

The total number of lifejackets should never be lower than the total persons allowed to be carried by the COI plus the number of additional lifejackets required at the watch stations. If the COI allows persons in addition to the crew to be carried, there must also be enough Coast Guard approved lifejackets of a suitable size for the additional persons.

Lifejacket lights that have a non-replaceable power source must be replaced on or before the expiration date of the power source. If the light has a replaceable power source, the power source must be replaced on or before its expiration date.

Lifejacket must be fitted with approved retro-reflective material in accordance with IMO Resolution A.658 (16). Each lifejacket is required to have at least 400 cm<sup>2</sup> (62 square inches) of retro-reflective material. If the lifejacket is reversible, an additional 400 cm<sup>2</sup> of properly fitted retro-reflective material would be required on the reversible side.

Other than on a vessel operating solely within a limited geographic area (LGA), all vessels with berthing must also carry additional approved lifejacket(s) at each watch station for every watch stander. The term "watch station" used in this section is not defined however; the intent is to have a lifejacket readily accessible at all times for persons standing watch(s) so they will be able to get a lifejacket quickly when needed. The bridge is one example of a watch station. Additional lifejacket(s) would need to be readily available for watch stander(s) on the bridge as well as other manned watch stations. Watch station determinations, and the need for additional lifejackets at those workstations, are at the discretion of the OCMI/TPO based upon the vessel arrangement and the operational area.

Whistle do not have an approval series; however, MSM Vol. II contains guidance on acceptable whistles.

#### **Items to check:**

- Sufficient number of lifejackets.
- All lifejackets Coast Guard approved.
  - Kapok lifejacket: [46 CFR 160.002](#)
  - Fibrous glass lifejacket: [46 CFR 160.005](#)
  - Unicellular plastic foam lifejacket: [46 CFR 160.055](#)
  - SOLAS lifejacket: [46 CFR 160.155](#)
  - Inflatable lifejacket: [46 CFR 160.176](#)
- Lifejackets properly stowed and readily accessible.
- If using inflatable lifejackets, all are a similar design and mode of operation.
- Lifejackets properly marked with the vessel name and retro-reflective material.
- Lifejackets fitted with an approved and serviceable lifejacket light.
- Lifejackets fitted with a serviceable whistle.
- Lifejacket in sound (serviceable) material condition – free of defects and/or unauthorized repairs.

#### **Regulatory Cites:**

[46 CFR 141.230](#) Readiness

[46 CFR 141.235](#) Inspection, testing, and maintenance

[46 CFR 141.340](#) Lifejackets

[46 CFR 164.018](#) Retroreflective Material for Lifesaving Equipment

[46 CFR 161.012](#) or [161.112](#) Personal Flotation Device Lights. Approval series 161.012 lights can only be used on domestic routes.

### **Additional Guidance:**

Commandant (CG-ENG-4) Lifesaving and Fire Safety Division

Marine Safety Manual Volume II

IMO Resolution A.658 (16) Use and Fitting of Retroreflective material on lifesaving appliances

IMO Resolution A.760 (18) Symbols related to life-saving appliances and arrangements

NVIC 02-63 Guide for Inspection and Repair of lifesaving Equipment

NVIC 01-94 Marking of Life Preservers and PFDs

NVIC 03-10 New SOLAS Requirements for Lifejackets and Immersion Suits Effective 1 JULY 2010

## **SOLAS Chapter III Compliant Vessel**

A towing vessel is allowed to reduce lifesaving equipment carriage requirements while operating on routes subordinate to the highest route authorized by the vessels COI. The equipment carriage reduction(s) are only allowed on towing vessels that operate on domestic routes and do not maintain international certificates – i.e. SOLAS certificates. Failure to properly maintain and/or have on board any lifesaving equipment required by an international certificate, regardless of the authorized route or the operational area, will invalidate the international certificate(s).

### **Regulatory Cites:**

46 CFR 141.105(c) Applicability and delayed implementation for existing vessels

## **Survival Craft**

Towing vessel survival craft carriage requirements are based on warm or cold water operation. Definitions for warm and cold water can be found in 46 CFR 136.110.

Substituting survival craft of higher precedence is allowed – i.e. an approved lifeboat can be substituted for any survival craft. The hierarchy of survival craft, from most protective to least protective, is lifeboat, inflatable liferaft, inflatable buoyant apparatus (IBA), life float, and rigid buoyant apparatus.

### **Items to check:**

- All survival craft Coast Guard approved:
  - Lifeboats: 46 CFR 160.135
  - Inflatable liferaft: 46 CFR 160.151
  - Inflatable liferaft: 46 CFR 160.051 (only allowed as a substitute for an inflatable buoyant apparatus)
  - Inflatable buoyant apparatus: 46 CFR 160.010
  - Life float: 46 CFR 160.027
  - Rigid buoyant apparatus: 46 CFR 160.010
- Survival craft readily accessible.
- Survival craft have enough capacity to accommodate the total number of persons authorized on the vessel's COI.
- Survival craft provide a means of sheltering appropriate for the route.
- Survival craft properly equipped.
- Survival craft fitted with retro-reflective material.
- Survival craft inspections, testing and maintenance completed and current.
- Survival craft in serviceable condition free of defects, deformities and/or unauthorized repairs.
- Survival craft properly stowed.
- Survival craft and stowage location(s) properly marked.

- If equipped with inflatable survival craft, instruction placards in place.
- If using a skiff to meet survival craft requirements:
  - Skiff is an authorized substitute
  - Adequate for the vessel's route
  - Can accommodate all persons on board the vessel
  - Properly marked

### **Regulatory Cites:**

[46 CFR 136.110](#) Definitions  
[46 CFR 141.230](#) Readiness  
[46 CFR 141.235](#) Inspection, testing, and maintenance  
[46 CFR 141.305](#) Survival craft requirements for towing vessels  
[46 CFR 141.310](#) Stowage of survival craft  
[46 CFR 141.315](#) Marking of survival craft and stowage locations  
[46 CFR 141.320](#) Inflatable survival craft placards  
[46 CFR 141.325](#) Survival craft equipment  
[46 CFR 141.330](#) Skiffs as survival craft  
[46 CFR 164.018](#) Retroreflective Material for Lifesaving Equipment  
[46 CFR 199.130](#) Stowage of survival craft  
[46 CFR 199.175](#) Survival craft equipment  
[46 CFR 199.176](#) Markings on lifesaving appliances  
[46 CFR 199.178](#) Marking of stowage locations

### **Additional Guidance:**

[Commandant \(CG-ENG-4\) Lifesaving and Fire Safety Division](#)  
[Marine Safety Manual Volume II](#)  
[IMO Resolution A.658 \(16\) Use and Fitting of Retroreflective material on lifesaving appliances](#)  
[IMO Resolution A.760 \(18\) Symbols related to life-saving appliances and arrangements](#)  
[NVIC 02-63 Guide for Inspection and Repair of lifesaving Equipment](#)  
[NVIC 04-86 Hydraulic Release Units for Life Rafts, Life Floats and Buoyant Apparatus, and Alternate Float-Free Arrangements](#)  
[NVIC 07-91 Determination of Cold Water Areas](#)

### **Visual Distress Signals**

Flare type signals are considered appropriate for both day and night use. Smoke type signals are only appropriate for use as day signals. Visual distress signal carriage requirements are based on the vessel's area of operation. The vessel will be required to carry a combination of either 3 day and 3 night signals or 6 day and 6 night signals. Vessels that carry visual distress signals that are approved as both day and night signals would only need to carry 3 or 6 visual distress signals, respectively. For example, if the vessel is required to carry 3 day and 3 night signals, then a total of 3 signals suitable for both day and night would satisfy the requirement.

The stowage and safe handling of distress signals is very important. Distress signals must be stored in a portable, watertight, brightly colored container marked "DISTRESS SIGNALS" in contrasting letters at the operating station or in a pyrotechnic locker located near the operating station.

A limited number of expired (outdated) distress signals may be carried aboard the vessel for training purposes. The expired signals must be stored in an appropriate container marked "OUTDATED – FOR DRILLS" and stored separately from the in service visual distress signals.



**Items to check:**

- Appropriate number of day and night signals for the vessels route.
  - All distress signals Coast Guard approved.
    - Day and night visual distress signals:
      - Hand-held red flare [46 CFR 160.021](#) or 160.121
      - Hand-held red rocket-propelled parachute red flare: [46 CFR 160.036](#) or 160.136
    - Day only visual distress signals:
      - Floating orange smoke: 46 CFR [160.022](#), 160.122 or 160.157
      - Hand-held orange smoke: [46 CFR 160.037](#)
  - Distress signals not expired.
  - Distress signals properly stowed and the stowage location properly marked.
  - Distress signals in serviceable condition.

**Regulatory Cites:**

[46 CFR 141.230](#) Readiness

[46 CFR 141.235](#) Inspection, testing, and maintenance

[46 CFR 141.375](#) Visual distress signals

**Additional Guidance:**

Commandant (CG-ENG-4) Lifesaving and Fire Safety Division

Marine Safety Manual Volume II

NVIC 02-63 Guide for Inspection and Repair of lifesaving Equipment

# Machinery and Electrical

## Alarms and Monitoring

A “reliable means” should be interpreted as having an adequate source of power for normal conditions as well as adequate power when vessel is operating on emergency power, if equipped.

### Items to check:

- Alarm for main engine low lubricating oil pressure.
- Alarm for main engine high cooling water temperature.
- Alarm for auxiliary generator engine low lubricating oil pressure.
- Alarm for auxiliary generator engine high cooling water temperature.
- Alarm for high bilge levels.
- Alarm for low hydraulic steering fluid levels, (if applicable).
- Alarm for high and low fuel levels if vessel equipped with day tanks.
- Alarm is visible and audible at each operating station.
- If alarm at operating station is a summary alarm, specific alarm is indicated at machinery or bilge location.
- Alarm has means to test at operating station or is continuous self monitoring and activates if there is an alarm point failure or it becomes disabled.

### Regulatory Cites:

[46 CFR 143.230](#) Alarms and monitoring

### Additional Guidance:

[NVIC 2-89](#), Guide for Electrical Installation on Merchant Vessels and MODUs - see 3.4 Battery and Battery Installations

[Marine Safety Manual Volume II](#) - see Sect B CH-1 Part L Emergency Lighting and Power Systems

## Bilge Pumps or Other Dewatering Capabilities

### Items to check:

- If vessel has installed bilge pump:
  - Installed bilge pump piping has foot valve or check valve at each bilge suction.
- If vessel has portable bilge pump:
  - Portable bilge pump has sufficient hose length and pumping capability.

### Regulatory Cites:

[46 CFR 143.275](#) Bilge pumps or other dewatering capability

### Additional Guidance:

[FAQs Part 143](#) - see FAQ 143-028

## Classed Vessel or Vessel built to Class Rules

### Items to check:

- Maintain vessel in class.
- Maintain vessel in accordance with applicable classification society rules.

### Regulatory Cites:

[46 CFR 136.110](#) Definitions - see "objective evidence

[46 CFR 143.215](#) Existing vessels built to Class

### Additional Guidance:

[FAQs Part 136](#) - see FAQ 136-011

[Marine Safety Center Plan Review Guidelines](#) - see E1-36, Design Verification of Machinery Systems-Towing Vessels and E2-31, Design Verification of Electrical Systems-Towing Vessels

## Communication Systems

### Items to check:

- This section does not apply to excepted vessels or those with more than one propulsion units.
- Pilothouse engine controls and engine room access are within 10 feet of each other, direct voice communications are acceptable in lieu of a communication system.
- Vessel is fitted with communication system between pilothouse and engine room.
- System has its own power supply and is independent of vessel electrical system.
- Provides two way communications between pilot house and engine room or location immediately adjacent to an exit from the engine room.

### Regulatory Cites:

[46 CFR 143.240](#) Communication requirements

### Additional Guidance:

[33 CFR 164.80](#) Tests, inspections, and voyage planning

[NVIC 2-89](#), Guide for Electrical Installation on Merchant Vessels and MODUs - see Chapter 5.

## Controls and Monitoring

### Items to check:

- Means to monitor and control thrust, rudder angle, and if applicable direction of thrust at each control station.
- If equipped with rudders has means of control and monitoring the position of the rudders at each operating station.

### **Regulatory Cites:**

46 CFR 136.110 Definitions (Operating station)  
46 CFR 143.225 Control and monitoring requirements  
46 CFR 143.230 Alarms and monitoring

### **Additional Guidance:**

FAQs Part 143 - see FAQs 143-004, -005, -006, -020, -023, -025, -030 and, -034.

## **Electrical Conductors, Connections and Equipment**

### **Items to check:**

- Conductors are properly sized for their current carrying load.
- Overhead and vertical cable runs are supported with metal supports and retention devices at least every 48 inches.
- Cables installed to reduce radio and magnetic compass interference.
- Cables are protected from weather.
- Cables supported to avoid chafing.
- Cables protected by metal covering or other suitable means if subject to mechanical abuse.
- Cables in refrigerated spaces suitable for low temperature and high humidity.
- Cables located outside of tanks.
- Cables located in tanks suitable for fluids in tank.
- No extension cords or multiple outlet adapters installed as a permanent power source.

### **Regulatory Cites:**

46 CFR 143.575 Electrical conductors, connections, and equipment

### **Additional Guidance:**

Marine Safety Manual Volume II see - Sect B Ch-1  
FAQs Part 143 - see FAQs 143-012, -013, -019, -021, -022, -026 and, -032  
ASTM F1507 (Standard Specifications for Surge Suppressors for Shipboard Use)  
UL 1449 (Safety Standards for Surge Protective Devices)

## **Electrical Distribution Panels and Switchboards**

### **Items to check:**

- Switchboards are accessible, insulated, and protected.
- Constructed properly to prevent accidental contact with energized parts.
- Non-conductive mats present on the deck in front of switchboard and at the rear if accessible.
- Current carrying parts properly insulated

### **Regulatory Cites:**

46 CFR 143.400 Electrical systems, general  
46 CFR 143.560 Electrical distribution panels and switchboards  
46 CFR 143.565 Electrical overcurrent protection other than generators and motors  
46 CFR 143.570 Electrical grounding and ground detection

### **Additional Guidance:**

[NVIC 2-89](#) Guide for Electrical Installations on Merchant Vessels and Mobile Offshore Drilling Units - see Chapter 3 - 5

[Marine Safety Manual Volume II](#) - see Section B Ch-1

[FAQs Part 143](#) - See FAQs 143-012, -013, -019, -021, -022, -026 and, -032

## **Electrical Grounding and Ground Detection**

### **Items to check:**

- Ungrounded distribution system has ground detection at main switchboard or distribution panel.
- Ungrounded distribution system is continually monitored for circuit status to ground.
- Dual voltage or grounded electrical system has neutral suitably grounded at main switchboard or distribution panel.
- Metallic vessel, grounded distribution system grounded to hull.
- Non metallic vessel, all electrical equipment grounded to common ground.

### **Regulatory Cites:**

[46 CFR 143.570](#) Electrical grounding and ground detection

### **Additional Guidance:**

[NVIC 2-89](#) Guide for Electrical Installations on Merchant Vessels and Mobile Offshore Drilling Units - see Chapter 3

NFPA NEC 2002 Section 250.119 and 250.122

[Marine Safety Manual VOL II](#) Section B Ch-1

[FAQs Part 143](#) - see FAQs 143-012, -013, -019, -021, -022, -026 and, -032[DSTC3]

## **Electrical Overcurrent Protection other than Generators and Motors**

### **Items to check:**

- Suitable overcurrent protection is available for vessel power and lighting systems.
- Essential systems and non-essential systems not on same circuit or sharing same overcurrent devices.

### **Regulatory Cites:**

[46 CFR 143.565](#) Electrical overcurrent protection other than generators and motors

### **Additional Guidance:**

[NVIC 2-89](#) Guide for Electrical Installations on Merchant Vessels and Mobile Offshore Drilling, Chapter 3

National Electrical Code (NEC) article 240

National Electrical Code (NEC) article 310.15(B)

National Electrical Code (NEC) article 450

[Marine Safety Manual Volume II](#) Chapter 1, Section B

[FAQs Part 143](#) - see FAQs 143-012, -013, -019, -021, -022, -026 and, -032

## Electrical Power Sources, Generators and Motors

### Items to check:

- Power source requirements adequate for all essential loads.
- Two independent sources for essential loads.
- Verify load analysis.
- Inspect condition and installation of generator(s) and prime mover(s) components and insure data plates are attached and legible.
- Protective covers and guards installed properly.
- Verify overcurrent protection at <115% of rated current.
- Battery installation installed as second source adequate for supplying essential loads.

### Regulatory Cites:

46 CFR 136.110 Definitions - see "Essential systems"  
46 CFR 143.220 Machinery space fire protection  
46 CFR 143.400 Electrical systems, general  
46 CFR 143.555 Electrical power sources, generators, and motors  
46 CFR 143.580 Alternative electrical installations  
46 CFR 144.820 Guards in dangerous places  
46 CFR 144.830 Protection against hot piping

### Additional Guidance:

NVIC 2-89 Guide for Electrical Installations on Merchant Vessels and Mobile Offshore Drilling Units - see Chapter 3-4  
Marine Safety Manual Volume II Section B Ch-1  
National Electrical Code (NEC) Parts I-VII, Article 430  
ABS Rules for Building and Classing Steel Vessels under 90 Meters in Length, Regulation 11  
FAQs Part 143 - see FAQs 143-012, -013, -019, -021, -022, 026 and, -032

## Electrical Systems

In general, minimizing shock and fire hazards for electrical systems means all current-carrying conductors must be protected by appropriately-sized protection device(s) to minimize shock and fire hazards. Warning signs as described in 143.250 (b) should be made of durable material, written in the language understood by all crew members and affixed as not to easily or mistakenly be removed.

### Items to check:

- Electrical equipment is marked with respective current and voltage ratings.
- Circuit breakers on switchboards and distribution panels are labeled with description of loads they serve.
- Electrical connections properly installed and secured from vibration.
- Electrical connections are protected from wet and corrosive environments.
- Electrical components that pose a hazard are enclosed.
- Electrical conductors that pass through watertight bulkheads are installed so that bulkhead remains watertight.
- Flexible cable plugs and sockets designed to prevent unintended separation.

### **Regulatory Cites:**

46 CFR 111.79 Receptacles  
46 CFR 129.220 Basic safety  
46 CFR 143.400 Electrical systems, general

### **Additional information:**

Marine Safety Manual Volume II Section B Ch-1  
FAQs Part 143 - see FAQs 143-012, -013, -019, -021, -022, 026 and, -032

## **Fuel Shutoff**

### **Items to check:**

- Vessel is not an excepted vessel.
- Fuel shutoff valve on any fuel line that is directly connected to propulsion engine or generator prime mover.
- Valve installed directly outside fuel supply tank.
- Valve is operable from a safe space outside of space where valve installed.
- Remote valve control is clearly marked IAW 143.260 (e).

### **Regulatory Cites:**

46 CFR 143.260 Fuel shutoff requirements

### **Additional Guidance:**

Commandant (CG-ENG-4) Lifesaving and Fire Safety Division  
SAE J1942  
FAQs Part 143 - see FAQ 143-018

## **Fuel System**

### **Items to check:**

- Fuel system for main engines and generators have documented maintenance plan.
- Fuel system has either filters or purifiers for a continuous supply of clean fuel.
- Adequate supply of spare clean filters available.
- Fuel filters replaced in accordance with manufactures requirements of or vessel TSMS.
- No other fuel sources used except those permitted under 143.210 or 143.520.
- No portable fuel systems except when used for outboard engines or portable bilge or fire pumps:
  - Portable tanks, fuel lines and accessories for those items list above, comply with ABYC (American Boat and Yacht Council) H-25.
- Integral fuel tanks properly vented:
  - Vent pipe(s) at the highest point on the tank(s).
  - Vent pipe(s) discharges on weather deck through a 180° bend.
  - Vent pipe(s) has 30-by-30 corrosion resistant flame screen.
  - Vent pipe(s) has cross sectional area > 312.3 square millimeters (0.484) for gravity filled tanks.
  - Cross sectional area for vent pipe(s) is not less than the cross sectional area of the fill pipe if tank filled by pump pressure.

- Fuel piping meets minimum standard:
  - Constructed of seamless steel, annealed copper, nickel-copper, or copper nickel.
  - Wall thickness of no less than 0.9 millimeters (0.035 inches).
  - If vessel is aluminum hull and fuel lines are aluminum piping of at least Schedule 80.
  - All non-metallic fuel hoses:
    - Less than 30 inches (0.76meters) in length.
    - Visible and easily accessible.
    - Fabricated with an inner tube and cover of synthetic rubber or other suitable material reinforced with wire braid.
    - If designed for use with compression fittings, is fitted with suitable corrosion resistant compression fittings or fittings compliant with SAE J1475-1996.
    - If designed for use with clamps, is installed with two clamps at each end of the hose.
    - Clamps:
      - Do not rely on spring tension.
      - Installed beyond the bead or flare or serrations of the mating spud, pipe, or hose fitting.
  - Hose meets SAE J1942-2005.

**Regulatory Cites:**

46 CFR 143.210 Alternate design or operational considerations  
 46 CFR 143.255 Fuel system requirements  
 46 CFR 143.265 Additional fuel system requirements for towing vessels built after January 18, 2000  
 46 CFR 143.520 Towing vessels built to American Boat and yacht Council standards

**Additional Guidance:**

American Boat and Yacht Council ABYC H-25  
 Marine Safety Manual Volume II Sect B CH-1  
 FAQs Part 143 - see FAQ 143-008 and -015

**General Alarms**

**Items to check:**

- Can be activated from each control station.
- Capable of notifying persons in any accommodations, work space, and engine room.
- Has flashing red light in engine room or other high noise spaces.
- Red light is identified with sign that reads: “Attention General Alarm – When Alarm Sounds or Flashes Go to your Station”.
- If General Alarm not installed, a public address system may be used that meets requirements of (b) (2) and (b) (3) of this section.

**Regulatory Cites:**

46 CFR 143.235 General alarms

**Additional Guidance:**

NVIC 2-89 Guide for Electrical Installations on Merchant Vessels and Mobile Offshore Drilling Units - see Chapter 5  
 Marine Safety Manual Volume II  
 FAQs Part 143 - see FAQ 143-016



## **General Requirements for Propulsion, Steering and Related Controls on Vessels that Move Tank Barges Carrying Oil or Hazardous Material in Bulk**

Subpart C, beginning with 46 CFR 143.500, is applicable to new towing vessels only.

### **Items to check:**

- Alternative means to control propulsion and steering.
- Alternative controls independent from primary system.
- Readily accessible and suitable for prolonged operations.
- Communication available between alternative and primary operating station(s)
- Means to stop propulsion engines and steering motors from each station.
- Means to monitor thrust, direction ahead or astern, and rudder angle.
- Control system designed so that in the event of single component failure propeller speed and direction of thrust are maintained or reduced to zero.
- Integrated steering and propulsion system (Z-Drive) designed so that in the event of any component failure of the system, propeller speed and direction of thrust are maintained or reduced to zero.
- Audible and visual alarms operate if:
  - Propulsion control system fails.
  - Non-follow up steering controls failed, if installed.
  - Ordered rudder angle does not match actual rudder position.
  - System properly designed to eliminate nuisance alarms.
  - Alarms separate and independent of system controls required by 143.225.
- Communication available between each operating station.
- Two electrical sources available to power electrical loads to maintain propulsion, steering and related controls for three hours.
- Second source automatically comes on line in event of main power failure.
- Propulsion, steering and controls that rely on stored energy such as batteries, hydraulic pressure, or compressed air must have two independent stored energy systems.
- Motors used to maintain propulsion and steering must automatically restart after power failure.
- Remote control restart available at operating stations.

### **Regulatory Cites:**

[46 CFR 136.110](#) Definitions, (New towing vessel)

[46 CFR 143.225](#) Control and monitoring requirements

[46 CFR 143.555\(a\)\(3\)\(b\)\(8\)](#) Electrical power sources, generators, and motors

[46 CFR 143.585](#) General requirements for propulsion, steering, and related controls on vessels that move tank barges carrying oil or hazardous materials in bulk

[46 CFR 143.590](#) Proposer redundancy on vessels that move tank barges carrying oil or hazardous material in bulk

[46 CFR 143.595](#) Vessels with one proposer that move tank barges carrying oil or hazardous material in bulk

Additional Guidance:

[FAQs Part 143](#) - see FAQ 143-033

[CVC-WI-011](#) Guidance on Overspeed Protection and Testing of Electronically-Controlled Engines

## **Pilothouse Alerter System**

Pilot house alerter system requirements on an existing towing vessel must be met no later than 5 years after the issuance of the initial COI.

The pilothouse alerter system acknowledgement time cannot exceed ten (10) minutes. The CG highly recommends that the acknowledgement time be reduced as appropriate for the route and service.

**Items to check:**

- Vessel has pilot house alerter system that meets the requirements of 46 CFR 143 (a) (1-3), (b), (c).
  - Alerter not needed if:
    - Vessel manned with second person in pilothouse while underway; or
    - Vessel is < 65 ft LOA.

**Regulatory Cites:**

46 CFR 143.200 Applicability  
46 CFR 143.450 Pilothouse alerter system

**Additional Guidance:**

SOLAS 14V/19.2.2.4

## **Piping Systems and Tanks**

Items to check:

- External piping is metal and leak free.

Regulatory Cites:

46 CFR 143.270 Piping systems and tanks

## **Pressure Vessels**

On existing vessels, these regulations are applicable for pressure vessels over 5 cubic feet in volume and over 15 PSI MAWP.

Pressure vessels installed on new towing vessels that are over 5 cubic feet in volume and over 15 PSI must meet ABS Rules for Building and Classing Steel Vessels under 90 feet in Length.

**Items to check:**

- Pressure vessel has visible working gauge.
- Pressure vessel has relief valve that prevents system pressure to never exceed MAWP by more than 10%.
- MAWP is stamped or on data plate and is visible to crew.

**Regulatory Cites:**

46 CFR 61.10 Tests and Inspection of Pressure Vessels  
46 CFR 143.245 Readiness and testing  
46 CFR 143.300 Pressure vessels  
46 CFR 143.545 Pressure vessels

**Additional Guidance:**

[Marine Safety Manual Volume II](#)

[NVIC 11-92](#) Guidance for Acceptance of the National Board of Boiler and Pressure Vessel Inspectors (NBBI) National Board Inspection Code (NBIC) for Repairs and Alterations to Boilers and Pressure Vessels

The National Board of Boiler and Pressure Vessel Inspectors, Recommended Administrative Boiler and Pressure Vessel Safety Rules and Regulations NB-132 Revision 8

**Pumps, Piping, Valves and Fittings for Essential System**

These regulations are only applicable for new towing vessels.

**Items to check:**

- Pumps, pipes, valves, and fittings in essential systems meet ABS rules for building and classing steel vessels under 90 meters (295 feet) in length.
  - If towing vessel operates exclusively on rivers and intracoastal waterways:
    - Pumps, pipes, valves, and fittings in essential systems may meet ABS rules for building and classing steel vessels for service on rivers and intracoastal waterways.

**Regulatory Cites:**

[46 CFR 136.112](#) Incorporation by reference

[46 CFR 143.540](#) Pumps, piping, valves, and fittings for essential systems

**Readiness and Testing**

These tests must be recorded in accordance with 46 CFR 140.

**Items to check:**

- Essential systems and equipment are tested and examined regularly.
- Tests and examinations verify systems and equipment function as designed.
- Unsatisfactory components are repaired or replaced.
- Tests and examinations are performed as per manufacturer’s instructions or the Towing Safety Management System (TSMS) if applicable.

<b>Test of:</b>	<b>Frequency:</b>
Propulsion controls; ahead and astern at the operating station.	Before the vessel gets underway, but no more than once in any 24 hour period.
Steering controls at the operating station	Before the vessel gets underway, but no more than once in any 24 hour period.

Pilothouse alerter system.	Weekly.
All alternate steering and propulsion controls.	At least once every 3 months.
Power supply for alarm actuation circuits for alarms required by § 143.230.	At least once every 3 months.
Communications required by § 143.240.	Weekly.
General alarm if the vessel is so equipped.	Weekly
Emergency lighting and power if the vessel is so equipped.	At least once every 3 months.
Charge of storage batteries if the vessel is so equipped, for emergency lighting and power.	At least once every 3 months.
Alarm set points.	Twice every 5 years, with no more than 3 years elapsing since last test.
Pressure vessel relief valves.	Twice every 5 years, with no more than 3 years elapsing since last test.
All other essential systems.	At least once every 3 months.

**Regulatory Cites:**

[46 CFR 143.245](#) Readiness and testing

**Additional Guidance:**

[NVIC 11-92](#) Guidance for Acceptance of the National Board of Boiler and Pressure Vessel Inspectors National Board Inspection Code (NBIC) for Repairs and Alterations to Boilers and Pressure Vessels  
[NVIC 2-89](#) Guide for Electrical Installations on Merchant Vessels and MODUs - see Chapter 5 [Marine Safety Manual Vol II Sect B Ch-1](#)

ASME Boiler and Pressure Vessel Code VIII Div 1, UG-126  
National Board of Boiler and Pressure Vessel Inspectors, NB-132 Rev 8

## Shipboard Lighting

### Items to check:

- Emergency lighting in all internal crew living and working spaces.
- If battery operated, provides illumination for not less than two hours.
- If non electric, phosphorescent adhesive strips, sufficient visibility available to egress in a no power condition.
- Two potable, battery powered lights. One in pilot house and one in engine room.

### Regulatory Cites:

46 CFR 143.410 Shipboard lighting

### Additional Guidance:

NVIC 2-89 Guide for Electrical Installations on Merchant Vessels and Mobile Offshore Drilling Units - see Chapters 3-5  
FAQs Part 143 - see FAQ 143-032

## Steering Systems

These regulations are only applicable to new towing vessels.

### Items to check:

- Steering systems meet ABS rules for building and classing steel vessels under 90 meters (295 feet) in length.
  - If towing vessel operates exclusively on rivers and intracoastal waterways:
    - Steering systems may meet ABS rules for building and classing steel vessels for service on rivers and intracoastal waterways

### Regulatory Cites:

46 CFR 136.112 Incorporation by reference  
46 CFR 137.220(d) Scope  
46 CFR 143.550 Steering systems

### Additional Guidance:

Marine Safety Manual Volume II Sect B Ch-1

## System Isolation and Markings

Isolation valves must be clearly marked. Use of color-coding in accordance with the vessel's TSMS permitted.

### Items to check:

- Electrical equipment provided with circuit isolations and marked as described in [143.400](#).
- Electrical panels and enclosures with multiple power sources have warning signs and identify where to secure power sources.
- Piping for combustible liquids, seawater cooling, or firefighting systems fitted with isolation valves and clearly marked or color coded to identify its function.
- All piping hull penetrations below the waterline fitted with accessible valve as close to penetration as practicable and clearly marked or color coded.
- Color coding meets ISO Standard 14726 or is in accordance with the TSMS applicable to this vessel.

### Regulatory Cites:

[46 CFR 143.250](#) System isolation and markings

### Additional Guidance:

ISO Standard 14726:2008(E)

## Towing Machinery

Existing towing vessels do not have to comply with these requirements until 5 years after the issuance of the initial COI.

New Towing vessels must be in compliance with these regulations prior to receiving an initial COI.

### Items to check:

- Towing machinery such as winches, capstans, and related equipment is adequate for intended route and service.
- Towing wires, hawsers, chains, shackles and fittings are adequate for intended route and service.
- Safeguards utilized to prevent unintentional release, are not disabled, and properly placarded.
- Procedures are in place for all towing equipment to be routinely examined, maintained, and/or replaced as needed.

### Regulatory Cites:

[33 CFR 157.04](#) Authorization of classification societies  
[33 CFR 164.74](#) Towline and terminal gear for towing astern  
[46 CFR 140.805](#) Towing safety  
[46 CFR 143.460](#) Towing machinery

### Additional Guidance:

[NVIC 5-92](#) Guidelines for Wire Rope Towing Hawsers  
[Marine Safety Manual Volume II](#)

U.S. Navy Towing Manual  
U.S. Navy Salvor's Handbook

# Navigation Safety Equipment

## Introduction

Navigation safety equipment requirements are based primarily on vessel length (under 39.4 feet or 39.4 feet and more in length). Regardless of the prescribed carriage requirement, all navigational safety equipment shall be properly maintained and fully functional aboard each towing vessel. Any navigational safety equipment that fails during a voyage must be repaired at the earliest practical time. When determining the repair of failed equipment and deciding whether it is safe for the vessel to proceed, prudent seamanship factors such as the condition of equipment, weather conditions, visibility and traffic shall be considered. Failures of navigation safety equipment and subsequent repairs need to be recorded in the official log, Towing Vessel Record, or in accordance with the towing vessel's TSMS if applicable.

### Regulatory Cites:

[33 CFR 164.01\(b\)](#) Applicability

[33 CFR 164.72](#) Navigational Safety Equipment Required on Towing Vessels

[33 CFR 164.82](#) Maintenance, Failure, and Reporting (towing vessels 39.4 feet or more)

[46 CFR 140.620](#) Navigational Safety Equipment (towing vessels under 39.4 feet)

## Automatic Identification System (AIS)

Items to check:

- AIS Class A device installed.
- Ability to reinitialize the AIS; includes access to power source and password.
- Ability to access AIS information from primary conning position on vessel.
- Accurate maritime Mobile Service Identity (MMSI) number.
- Accurate input and upkeep of all AIS data fields and system updates.
- Continual operation of AIS and supporting equipment.

Regulatory Cites:

[33 CFR 164.46](#) Automatic Identification System

[46 CFR 140.725](#) Additional navigation equipment

Additional Guidance:

[NVIC 8-01 CH-2](#) Approval of Navigation equipment for ships

[Coast Guard Navigation Center](#)

## Communications

Installed VHF-FM radio must be capable of monitoring VHF-FM Channels 13 and 16, except when transmitting or receiving traffic on other VHF-FM channels, when participating in a Vessel Traffic Service (VTS) or when monitoring a channel of a VTS.

For information regarding Bridge to Bridge Act inspection and certification requirements, see FCC in the Credentials, Documents and Reports section.



**Items to check:**

- One (1) handheld VHF-FM radio.
- One (1) VHF-FM radio with two (2) receivers or two (2) VHF-FM radios installed at operator's station.
- VHF-FM radio connected to a functioning battery backup.
- Ability to receive on Channel 13 or Channel 67 (for sections of the Lower Mississippi River) and separately monitor Channel 16.
- Radio-station license for radio transmitters.
- Radio operator holds restricted operator's license or higher.

**Regulatory Cites:**

33 CFR 26 Vessel Bridge-To-Bridge Radiotelephone Regulations

33 CFR 164.72(a)(3) VHF-FM Radio

46 CFR 140.715 Communication Equipment

**Echo Depth-Sounding Device****Items to check:**

- Echo depth-sounding device
- Readable from vessel's main steering station

**Regulatory Cites:**

33 CFR 164.72(a)(5) Echo Depth-sounding Device

46 CFR 140.725 Fathometer

**Additional Guidance:**

[TVNCOE Part 140 FAQs](#). See question 140-043.

**Electronic Position-Fixing Device****Items to check:**

- The GPS automatically acquires satellite signals after initial operation settings have been entered
- Position updates derived from satellite information during each usable satellite pass

**Regulatory Cites:**

33 CFR 164.72(a)(6) Electronic Position-Fixing Device

33 CFR 164.41 Electronic Position-Fixing Devices

46 CFR 140.725 (c) Electronic Position -Fixing Device

**Additional Guidance:**

[NVIC 01-16 Ch-1 Use of Electronic Charts and Publications in lieu of Paper Charts, Maps and Publications](#) - contains an equivalency for electronic position fixing device

## Internal Communications

When pilothouse engine controls and the access to the engine room are within 3m (10ft) of each other and allow for unobstructed visible contact, direct voice communication is acceptable instead of a communications system.

### Items to check:

- Fixed or Portable communication system between pilothouse and engine room.
- Main or Reserve power independent of towing vessel's electrical system.
- Provides two-way voice communication between pilothouse and either the engine room or location immediately adjacent to an exit from the engine room.

### Regulatory Cites:

46 CFR 143.240 Communication Requirements

## Magnetic Compass or Swing Meter

### Items to check:

- An illuminated card type magnetic steering compass or;
  - An illuminated swing meter (Western Rivers only)
- Visible from vessel's main steering station

### Regulatory Cites:

33 CFR 164.72(a)(4) Magnetic Compass

46 CFR 140.725(d) Illuminated Magnetic Compass or Illuminated Swing-meter

## Marine Radar

Compliance with RTCM standards is difficult to verify. The following is a summary of features found on marine radars in compliance with RTCM recommended standards:

- Range scales:
  - Less than 300 GRT, range scales of 0.25, 0.5, 0.75/0.8, 1.5, 3.0, 12.0 and 24.0 NM.
  - Equal to or greater than 300 GRT, ranges scales of 0.05-0.08 (minimum), 1.5, 3.0, 6.0, 12.0, 24.0 NM.
- Display:
  - Has means of plotting target track history (echo trails, etc.)
  - Has fixed electronic range rings
  - Has variable range marker (VRM) with numeric readout.
  - Meets minimum diagonal/diameter display sizes:
    - 10" for LCD
    - 9" for CRT
- Heading Indicator: Indicated electronically from own ship to edge of display.
- Bearing Measurement: Electronic Bearing Line (EBL) able to quickly obtain the bearing of any object whose echo appears on the display.
- Discrimination: Needs to meet minimum performance standard which typically requires a rotating array (antenna). Most dome arrays will not meet this requirement.
- Anti-Clutter: Suitable means to suppress unwanted echoes.

**Items to check:**

- Meets Federal Communications Commission (FCC) requirements of 47 CFR 80
- Meets RTCM Standard

**Regulatory Cites:**

46 CFR 140.710 Marine Radar  
33 CFR 164.72(a)(1) Marine Radar

**Additional Guidance:**

[RTCM Website](#)

**Navigation Lights and Shapes****Items to check:**

- If vessel is less than 65 ft, lights meets requirement of 33 CFR 183.810 or Underwriters Laboratories (UL) standard 1104. 46 CFR 143.415
- If vessel is 65 ft or greater, lights meet Underwriters Laboratories (UL) standard 1104 or other standards accepted by the Coast Guard. 46 CFR 143.415

**Regulatory Cites:**

33 CFR 83-90 Inland Navigation Rules  
46 CFR 143.415 Navigation Lights  
46 CFR 140.720 Navigation Lights, Shapes and Sound Signals  
Pubic Law 95-75; 91 Statute 308; 33 U.S.C. Chapter 30 1601-1608 International Regulations for Preventing Collisions at Sea (COLREGS)

**Searchlight****Items to check:**

- Controllable from the operating station
- Capable of illuminating objects at distance of two times the length of the tow

**Regulatory Cites:**

33 CFR 164.72(a)(2) Searchlight  
46 CFR 140.725(b) Searchlight

**Sound Producing Device**

A power-driven vessel normally engaged in pushing ahead or towing alongside may, at all times, use a whistle characteristic for the longest customary configuration length of the vessel and its tow. 33 CFR 86.01

Vessel Length	Whistle	Bell	Gong	Other means of making an efficient sound signal
<12 meters				x
12 meters	x			
20 meters	x	x		
100 meters	x	x	x	

**Items to check:**

Ensure the vessel is provided with the equipment according to its length. The bell or gong or both may be replaced by other equipment having the same respective sound characteristics, provided that manual sounding of the prescribed signals shall always be possible.

**Regulatory Cites:**

33 CFR 83.33 Equipment for sound signals (Rule 33)

33 CFR 86.01 Whistles

33 CFR 86.02 Bell or Gong

# Operations

## Auto Pilot

### Items to check:

- Means to immediately establish manual control of the ship's steering
- A competent person is ready at all times to take over steering control
- The changeover from automatic to manual steering and vice versa is made by, or under, the supervision of the officer in charge of the navigational watch

### Regulatory Cites:

33 CFR 164.13 Navigation underway: tankers (including Integrated Tug and Barge combinations)  
46 CFR 140.670 Use of auto pilot

## Compressed Gasses

### Regulatory Cites:

46 CFR 147.60 Compressed gases.  
46 CFR 147.70 Acetylene.  
46 CFR 147.85 Oxygen.

## Emergency Drills and Instruction

All crewmembers must be capable of performing their expected duties during emergencies aboard the vessel. It is the Master's responsibility to facilitate drills and instruction required by 46 CFR 140.420 and record the events in the Towing Vessel Record, official logbook, or as described in the vessel's TSMS. It is important for drills to be conducted aboard the vessel as if there were an actual emergency. All crewmembers are responsible for actively participating in drills and instruction, and as far as practicable, have actual use of emergency equipment.

### Items to check:

- Vessel records confirming that drills and instructions have been performed for:
  - Abandoning the vessel
  - Recovering persons from the water
  - Responding to onboard flooding
  - Responding to threats to the environment
  - Responding to other threats to life or property deemed necessary to particular vessel operations
- Vessel records confirming that monthly drills and instructions have been performed for response to fire aboard the vessel as required by 46 CFR 142.245.
- Vessel records confirming that drills and instructions have been performed for launching a skiff to abandon ship or recover a person overboard (if the skiff is listed as emergency equipment).
- Vessel records confirming that instructions have been performed for the use of davit-launched life rafts (if installed on vessel).
- Vessel records confirming that drills and instructions have been performed for the launching and use of a rescue boat during a man-overboard situation (if vessel is equipped with a rescue boat).

### **Regulatory Cites:**

[46 CFR 140.420](#) Emergency drills and instruction  
[46 CFR 140.915](#) Items to be recorded  
[46 CFR 142.245](#) Requirements for training crews to respond to fires

## **Emergency Duties and Duty Stations**

Formalized emergency station bills must be posted aboard all towing vessels when crewmembers perform rotating watches, or when the vessel is outfitted with overnight accommodations. Emergency duties and duty station information must be posted at each operating station and common crew areas. All crewmembers are responsible for actively participating in shipboard safety initiatives such as vessel familiarization, emergency drills and training.

### **Items to Check:**

- Verify duty station information has been posted
- Verify that crewmembers are familiar with their assigned emergency duties

### **Regulatory Cites:**

[46 CFR 15.405](#) Familiarity with vessel characteristics  
[46 CFR 15.1105](#) Familiarization and basic training (BT)  
[46 CFR 140.405](#) Emergency duties and duty stations

### **Additional Guidance:**

[NVIC 07-82](#) Sample Format of Vessel or Facility Station Bill

## **Examinations and Tests**

All towing vessels are required to perform pre-voyage inspections and tests of specific systems prior to getting underway. Specific inspections and tests are determined by towing vessel length (over or under 39.4 feet in length) and must be recorded in the TVR, official logbook, or in accordance with the towing vessel's TSMS.

### **Items to Check:**

- Verify log entries confirming pre-voyage inspections have been completed.

### **Regulatory Cites:**

[33 CFR 164.01](#) Applicability  
[33 CFR 164.80](#) Tests, inspections, and voyage planning. Towing vessels exceeding 39.4 feet or more in length.  
[46 CFR 140.615](#) Examinations and tests. Towing vessels less than 39.4 feet in length.  
[46 CFR 140.915](#) Items to be recorded

## **Fall Overboard Prevention**

All towing vessels, regardless of compliance option chosen, must have established procedures in place for preventing falls overboard and recovering persons in the water as required by [46 CFR 140.425](#). These

procedures should not be confused with the fall overboard requirements of the Safety and Health Plan in 46 CFR 140.510.

**Regulatory Cites:**

46 CFR 140.425 Fall overboard prevention

46 CFR 140.510 Identification and mitigation of health and safety hazards

## First Aid Equipment

**Items to check:**

- All towing vessels must be equipped with an industrial type first aid kit that is appropriate to the vessel's operational conditions and crew size.
- If the towing vessel is operating on oceans, coastwise, or Great Lakes, it must also have a means to take blood pressure readings, splint broken bones, and apply large bandages for serious wounds.

**Regulatory Cites:**

46 USC 11102 Medicine chests

46 CFR 140.435 First aid equipment

**Additional Guidance:**

DHHS Publication No. (PHS) 84-2024 The Ship's medicine chest and medical aid at sea

## Fuel for Cooking, Heating, and Lighting

**Regulatory Cite:**

46 CFR 147.50 Fuel for cooking, heating, and lighting.

## General Vessel Operation

Requirements to operate vessels in accordance with all applicable laws and regulations for the safety of life, property, and the environment are stated in 46 CFR 140.205.

**Items to check:**

- Ensure that vessels operating under a TSMS have addressed and are operating to the TSMS elements prescribed in 46 CFR 138.220. Policies and procedures of the TSMS should clearly state the company's requirements for vessel maintenance, surveys, safety, environmental protection, security, emergency preparedness, company management organization and addressing non-conformities.
- Verify that the towing vessel is properly manned. Crew complement shall match the COI manning requirement.
- Ensure that each crewmember aboard has their MMC (if required).
- Ensure that each crewmember aboard that is not required to have an MMC has a valid alternate form of identification.
-

## Regulatory Cites:

33 CFR 101.515 TWIC/Personal Identification  
46 CFR 15.515 Compliance with certificate of inspection  
46 CFR 15.535 Towing Vessels  
46 CFR 138 Towing Safety Management Systems (TSMS)  
46 CFR 140.205 General Vessel Operation

## Hazardous Ships Stores

Labels and placards for hazardous materials transportation:



## Regulatory Cites:

46 CFR 147.15 Hazardous ships' stores permitted on board vessels.  
46 CFR 147.30 Labeling.  
49 CFR 172.101 Purpose and use of hazardous materials table.  
49 CFR 173.2 Hazardous materials classes and index to hazard class definitions.  
49 CFR 173.2(a) Classification of a material having more than one hazard.

## Health and Safety Plan

All towing vessels must have an operational Safety and Health Plan in place no later than July 22, 2019. New towing vessels must have a Safety and Health Plan in place upon initial operations. The primary objective of a Safety and Health plan is to identify and implement procedures for the management of health and safety issues aboard the towing vessel. 46 CFR 140, Subpart E (Safety and Health) establishes the general contents of the Safety and Health Plan as well as identification and mitigation



requirements for 14 specific safety and health concerns. The Safety and Health Plan shall also contain specific training requirements associated with the plan.

Safety and Health plan procedures shall address the reporting of unsafe conditions, proper use of equipment, ensuring equipment is in proper working order, availability of proper PPE, fall overboard prevention, and control measures for addressing identified safety issues. The safety and health topics identified in Subpart E are the minimum requirements for a Safety and Health Plan and may be expanded to address vessel specific hazard awareness.

The Safety and Health Plan shall be readily available aboard the towing vessel and may be a standalone document or incorporated into the TSMS. Towing vessels operating under an existing safety management system may already have the elements of the Safety and Health Plan covered within their SMS.

There is no requirement to submit Safety and Health Plans to the Coast Guard or TPO for approval; however, the plan is subject to review during inspections and audits.

#### **Items to Check:**

- Procedures implemented for reporting unsafe conditions
- Records of any health and safety incidents that occurred on board the vessel
- Machinery and equipment not in proper working order removed or made safe through marking, tagging, or covering; or otherwise made unusable.
- Appropriate Personal Protective Equipment (PPE) available for all personnel
- PPE cleaned, maintained, and repaired in accordance with manufacturer's requirements
- All personnel trained in the proper use, limitations, and care of PPE
- Vessel, including crew's quarters and the galley in sanitary condition
- Procedures in place to identify and mitigate health and safety hazards:
  - Tools and equipment
  - Slips, trips, and falls
  - Working aloft
  - Hazardous materials;
  - Confined space entry
  - Blood-borne pathogens and other biological hazards
  - Electrical
  - Noise
  - Falls overboard
  - Vessel embarkation and disembarkation (including pilot transfers)
  - Towing gear, including winches, capstans, wires, hawsers and other related equipment
  - Personal hygiene
  - Sanitation and safe food handling
  - Potable water supply
- All crewmembers provided with the following health and safety information and training (as applicable to the vessel) within 5 days of employment :
  - Content and procedures of the health and safety plan
  - Procedures for reporting unsafe conditions
  - Proper selection and use of PPE
  - Safe use of equipment including deck machinery, rigging, welding and cutting, hand tools, ladders, and abrasive wheel machinery
  - Hazard communication and cargo knowledge
  - Safe use and storage of hazardous materials and chemicals
  - Confined space entry
  - Respiratory protection

- Lockout/Tag-out procedures
- Refresher training conducted annually
- Individuals, other than crewmembers, provided with sufficient information or training on hazards relevant to their potential exposure on or around the vessel

**Regulatory Cites:**

29 CFR 1910 subpart I Personal Protective Equipment  
 46 CFR 140.500 General  
 46 CFR 140.505 General health and safety requirements  
 46 CFR 140.510 Identification and mitigation of health and safety hazards  
 46 CFR 140.515 Training requirements

**Inspections and Testing Before Installations, Alterations or Repairs that Involve Hot Work**

Pre-task planning, inspecting, and testing are required when hot work must be accomplished in certain locations aboard a towing vessel. Prior to starting alterations, repairs, welding, cutting, or other fire producing operations within the locations listed in 140.665, a marine chemist must determine the operation can be undertaken with safety – includes the hot work and any required entry. 140.665 also describes the process of inspection and testing in the event a marine chemist is not available. The safety and health plan shall also address confined space entry procedures which may prescribe additional requirements prior to starting any hot work.

**Regulatory Cites:**

46 CFR 140.665 Inspection and testing required when making alterations, repairs, or other such operations involving riveting, welding, burning or like fire-producing actions

**Additional Guidance:**

NFPA 306 Standard for the Control of Gas Hazards on Vessels

**Navigation Assessment**

Underway navigational operations require pre-voyage planning and continuous updating of the plan throughout the voyage. Prior to getting underway, the master or navigational watch officer must perform the navigation assessment (a type of voyage plan) for the intended route. The navigation assessment will consider and address operational risks and crew workload demands expected during the voyage. During each navigational watch change, the officers in charge of the navigational watch shall review the assessment including changes within the plan and formally acknowledge the watch change with a log entry in the official logbook, towing vessel record, or in accordance with the TSMS. Log entries and records of navigation assessments shall be retained for at least one year after the date of the latest entry.

Certain towing vessels will need to comply with voyage planning requirements of 46 CFR 140.635 and 33 CFR 164.80.

**Items to check:**

- Velocity and direction of currents in the area being transited  
 Water depth, river stage, and tidal state along the route and at mooring location
- Prevailing visibility and weather conditions and changes anticipated along the intended route
- Density (actual and anticipated) of marine traffic

- The operational status of pilothouse instrumentation and controls, to include alarms, communication systems, variation and deviation errors of the compass, and any known nonconformities or deficiencies
- Air draft relative to bridges and overhead obstructions taking tide and river stage into consideration
- Horizontal clearance, to include bridge transits
- Lock transits
- Navigation hazards such as logs, wrecks or other obstructions in the water
- Any broadcast notice to mariners, safety or security zones or special navigation areas
- Configuration of the vessel and tow, including handling characteristics, field of vision from the pilothouse, and activities taking place onboard
- The knowledge, qualifications, and limitations of crewmembers who are assigned as members on watch and the experience and familiarity of crewmembers with the towing vessels particulars and equipment
- Any special conditions not covered above that impact the safety of navigation

**Regulatory Cites:**

33 CFR 164.80 Tests, inspections, and voyage planning  
 46 CFR 140.635 Navigation assessment  
 46 CFR 140.640 Pilothouse resource management  
 46 CFR 140.910 Towing vessel record or record specified by TSMS  
 46 CFR 140.915 Items to be recorded

**Navigational Safety Equipment**

Required navigational safety equipment must be properly maintained and fully functional aboard each towing vessel. Any navigational safety equipment that fails during a voyage must be repaired at the earliest practical time. When determining the repair of failed equipment and deciding whether it is safe for the vessel to proceed, prudent seamanship factors such as the condition of equipment, weather conditions, visibility and traffic shall be considered. Failures of navigation safety equipment and their subsequent repairs are to be recorded in the official log, Towing Vessel Record, or in accordance with the towing vessel’s TSMS if applicable.

Refer to the Navigation Safety Equipment section for more information about specific equipment requirements.

**Regulatory Cites:**

33 CFR 164.01(b) Applicability  
 33 CFR 164.46 Automatic Identification System  
 33 CFR 164.72 Navigational Safety Equipment Required on Towing Vessels  
 33 CFR 164.82 Maintenance, failure, and reporting. Towing vessels 39.4 feet or more in length.  
 46 CFR 140.620 Navigational safety equipment. Towing vessels less than 39.4 feet in length.  
 46 CFR 140.915 Items to be recorded

**Additional Guidance:**

NVIC 8-01 CH-2 Approval of Navigation equipment for ships

## Navigation Safety Training

Credentialed mariners holding Able Seaman or officer endorsements will be deemed to have met the training requirements in this section.

### Items to check:

- Each crewmember must receive training to ensure they are familiar with the following:
- Watchstanding terms and definitions
- Duties of a lookout
- Communication with other watchstanders
- Change of watch procedures
- Procedures for reporting other vessels or objects
- Watchstanding safety.

### Regulatory Cites:

46 CFR 140.645 Navigation safety training

## Official Logbook

An official logbook is required when:

- On a voyage between a US port and a foreign port, with the exception of a voyage from a US port to a Canadian port.
- The vessel is over 100 GRT when on a voyage between a port in the United States on the Atlantic Ocean and port in the United States on the Pacific Ocean.

The Coast Guard will provide official logbooks to vessel masters, and the required entries are listed within. Entries, and or corrections to entries, must include the date and time of the entry and name of the person making the entry.

**Note:** 46 U. S. Code Chapter 113, titled *Official Logbooks*, lists specific requirements of record keeping within the official logbook. 46 CFR 140.915 lists additional record keeping requirements to be maintained in the official logbook for compliance with Subchapter M.

### Items to check:

- Official Logbook contains required entries:
  - Personnel records – 46 CFR 140.400
  - Safety orientation – 46 CFR 140.410
  - Record of drills and instruction – 46 CFR 140.420
  - Examinations and tests – 46 CFR 140.615
  - Operative navigational safety equipment – 46 CFR 140.620
  - Navigation assessment – 46 CFR 140.635
  - Navigation safety training – 46 CFR 140.645
  - Oil residue discharges and disposals – 46 CFR 140.655
  - Record of inspection of towing gear – 46 CFR 140.820
  - Fire-detection and fixed fire-extinguishing – 46 CFR 142.240

### **Regulatory Cites:**

46 CFR 140.905 Official logbooks  
46 CFR 140.915 Items to be recorded  
46 USC 11301 Logbook and entry requirements

### **Personnel Records**

The towing vessel master is responsible for keeping accurate lists of crewmen aboard with their positions, responsibilities, and information regarding watch changes. This information shall be entered into the Towing Vessel Record, official logbook, or in accordance with the vessel's TSMS.

#### **Items to check:**

- Verify that entries have been made to account for all crewmen, persons in addition to the crew and passengers aboard.
- Verify that entries have been made indicating changes of the navigational watches, changes of lookouts and engineering watch changes.

### **Regulatory Cites:**

46 CFR 140.400 Personnel records  
46 CFR 140.915 Items to be recorded

### **Safety Orientation**

Prior to getting underway for the first time on a particular towing vessel, each new crewmember must receive a safety orientation. The orientation shall review the crewmember's duties during various types of emergencies and operational instructions of specific response equipment. The safety orientation must be documented in the Towing Vessel Record (TVR), official logbook, or as described in the vessel's TSMS.

#### **Items to Check:**

- Each crewmember has received a safety orientation on the following:
  - His or her duties in an emergency
  - The location, operation, and use of lifesaving equipment
  - Prevention of falls overboard
  - Personal safety measures
  - The location, operation, and use of Personal Protective Equipment
  - Emergency egress procedures
  - The use and operation of watertight and weathertight closures
  - Responsibilities to provide assistance to individuals that are not crewmembers
  - How to respond to emergencies relative to the tow
  - Awareness of, and expected response to, any other hazards inherent to the operation of the towing vessel which may pose a threat to life, property, or the environment.
- Crewmember orientation documented in the TVR, official logbook, or in accordance with the TSMS including:
  - The date of the safety orientation or training;
  - A general description of the safety orientation or training topics;
  - The name(s) and signature(s) of individual(s) providing the orientation or training
  - The name(s) of the individual(s) receiving the safety orientation or training
- Personnel not part of the crew have received a safety orientation on the following:

- The location, operation, and use of lifesaving equipment
- Emergency procedures
- Methods to notify crewmembers in the event of an emergency
- Prevention of falls overboard

**Regulatory Cites:**

- 46 CFR 15.405 Familiarity with vessel characteristics
- 46 CFR 15.1105 Familiarization and basic training
- 46 CFR 140.410 Safety Orientation
- 46 CFR 140.415 Orientation for individuals that are not crewmembers
- 46 CFR 140.915 Items to be recorded

**Refrigerants**

**Items to check:**

- Ship's stores refrigerants carried are listed in ANSI/ASHRAE 34-78.

**Regulatory Cite:**

- 46 CFR 147.90 Refrigerants.

**Additional Guidance:**

ASHRAE Refrigerant Designations.

**Towing Vessel Record (TVR) or Record Specified by TSMS**

A chronological record of events must be maintained by all towing vessels with the exception of towing vessels operating in a [limited geographic area](#) (46 CFR 140.910 (a)). Record keeping requirements for vessels maintaining an official logbook are discussed in 46 CFR 140.905. The TVR may be in paper or electronic form, and must be maintained in accordance with the vessels TSMS. Entries, and or corrections to entries, must include the date and time of entry and name of the person making the entry. Required record keeping must be entered into the TVR or as prescribed by the vessel's TSMS.

**Items to check:**

- TVR contains required entries:
  - Personnel records – 46 CFR 140.400
  - Safety orientation – 46 CFR 140.410
  - Record of drills and instruction – 46 CFR 140.420
  - Examinations and tests – 46 CFR 140.615
  - Operative navigational safety equipment – 46 CFR 140.620
  - Navigation assessment – 46 CFR 140.635
  - Navigation safety training – 46 CFR 140.645
  - Oil residue discharges and disposals – 46 CFR 140.655
  - Record of inspection of towing gear – 46 CFR 140.820
  - Fire-detection and fixed fire-extinguishing – 46 CFR 142.240

### **Regulatory Cites:**

46 CFR 140.910 Towing vessel record or record specified by TSMS

46 CFR 140.915 Items to be recorded

## **Vessel Stability**

### **Items to check:**

- Watertight and weathertight hatches doors, and opening function properly.
- Watertight and weathertight decks and bulkheads properly maintained.
- Except as authorized, all hatches and openings of the hull and deck kept closed.
- All watertight doors in watertight bulkheads closed during operation unless they are being used for transit between compartments.
- All exterior main deck openings kept closed during downstreaming.
- Decks and bulkheads designed to be watertight or weathertight maintained in that condition.
- All watertight doors in watertight bulkheads kept closed except:
  - When in use for transit between compartments.
  - When operating on lakes, bays, and sounds, without a tow during calm weather, and only if the master determines that the safety of the vessel is not compromised.
  - When operating on rivers with a tow, if the master determines the safety of the vessel is not compromised.

### **Regulatory Cites:**

46 CFR 140.605 Vessel stability

46 CFR 140.610 Hatches and other openings

Marine Safety Alert 1-08 Maintaining Vessel Watertight Integrity

NVIC 17-82 Intact Stability of Small Vessels; Recommendation

## **Wearing of Work Vests**

Work vests are considered safety equipment and shall not be accepted in lieu of any portion of the required number of approved lifesaving appliances. If work vests are utilized to comply with 46 CFR 140.430 they must be approved under 46 CFR 160.053.

### **Items to Check:**

- All work vests Coast Guard approved under approval series 46 CFR 160.053
- Work vest lights approved under approval series 46 CFR 161.012 or 46 CFR 161.112 (SOLAS)
- Work vest storage location properly marked "Work Vest"

### **Regulatory Cites:**

46 CFR 140.430 Wearing of work vests

46 CFR 141.340 Lifejackets

46 CFR 141.350 Immersion Suites

46 CFR 160.053 Work Vests, Unicellular Plastic Foam

46 CFR 161.012 Personal Flotation Device Lights

# Pollution Prevention Equipment

## Marine Sanitation Device (MSD)

No person may operate any vessel equipped with installed toilet facilities unless it is equipped with an operable MSD. "Porta-potties" are not considered as installed toilet facilities. If the vessel has a type I or II MSD and does not have an adequate stock of chemicals on board, these MSDs are not considered operable.

Properly operating Type I and II MSDs are devices that produce an effluent and solids that do not exceed regulatory limitations. A Type III MSD is designed to prevent the overboard discharge of treated or untreated sewage or any waste derived from sewage.

Most Type I and II MSD's require the use of chlorine tables to function properly. Contact between petroleum products and chlorine tablets may cause fires and explosions. Chlorine tables must be properly stored IAW manufacturer instructions and the Material Safety Data Sheet.

Some Type III MSDs use incineration to prevent the discharge of untreated sewage; however, most are configured with a "Y" valve to retain untreated sewage in a holding tank on board the vessel while operating on the Navigable Waters of the United States. If the vessel's route does not routinely take it into coastal waters beyond the Navigable Waters of the United States where untreated sewage can be legally discharged, the installation of a "Y" valve-equipped Type III MSD is inappropriate; these vessels must be equipped with an alternate means of discharging untreated sewage from the holding tank to a shore-based sewage treatment facility.

When operating a vessel in a no discharge zone where the discharge of treated or untreated sewage is prohibited by the EPA under 40 CFR 140.3 or 140.4, each Type I, II and III MSD must be secured in a manner which prevents discharge of treated and/or untreated sewage. For Type I and II MSDs, acceptable methods of securing the device include closing the seacock and removing the handle; padlocking the seacock in the closed position; using a non-releasable wire-tie to hold the seacock in the closed position; or locking the door to the space enclosing the toilets with a padlock or door handle key lock. For a Type III MSD, acceptable methods of securing the device include closing each valve leading to an overboard discharge and removing the handle; padlocking each valve leading to an overboard discharge in the closed position; or using a non-releasable wire-tie to hold each valve leading to an overboard discharge in the closed position.

### Items to check:

- MSD installed is appropriate for length of vessel and operating area:
  - Vessel 65 ft or less in length:
    - Type I
    - Type II
    - Type III
  - Vessel over 65 ft in length:
    - Type II
    - Type III
  - If Type I or II is installed:
    - Adequate supply of chemicals on board IAW manufacturer
    - Proper certification label and operating placard that contains:
      - Operating instructions
      - Safety precautions
      - Warnings pertinent to the device.



- Lettering one-eighth of an inch or larger
  - If the vessel operates in a no discharge zone(s) there is a means to secure the device in a manner which prevents discharge of treated or untreated sewage.
- If Type III with “Y” valve is installed, it properly secured

**Regulatory Cites:**

33 CFR Part 159 Marine Sanitation Devices  
 33 CFR 159.7 Requirements for vessel operators  
 33 CFR 159.59 Placard  
 33 CFR 159.65 Chemical level indicator  
 40 CFR Part 140 Marine Sanitation Device Standard  
 40 CFR 140.3 Standard  
 40 CFR 140.4 Complete prohibition

**Additional Guidance:**

[Marine Safety Manual Volume II](#)

**Oil Pollution Prevention**

Towing vessels must have the capacity to retain on board all oily mixtures and be equipped to discharge those oily mixtures to a reception facility. Oceangoing vessels, as an alternative, may be equipped with an approved oily-water separating equipment for processing oily mixtures from bilges and discharges into the sea according to 33 CFR 151.10. Vessels may retain oily mixtures onboard in the bilges; however; no person may intentionally drain oil or hazardous materials from any source into the bilge - see 33 CFR 155.770.

Vessels 300 GRT or more constructed after June 30, 1974 must have a fixed container or enclosed deck area under or around each fuel oil, bulk lubricating oil tank vent, overflow, and fill pipe with capacities as follows:

- At least one-half barrel for a vessel a less than 1600 GRT
- At least one barrel for a vessel 1600 GRT or more

A vessel of 100 GRT or more constructed before July 1, 1974 and a vessel of 100 or more but less than 300 GRT constructed after June 30, 1974 must meet the above requirements or, during oil transfer operations, equip each fuel oil, bulk lubricating oil tank vent, overflow, and fill pipe with a portable container of at least a 5 U.S. gallon capacity or, if the vessel has a fill fitting for which containment is impractical, use an automatic back pressure shut-off nozzle. 33 CFR 155.320.

Towing vessels over 300 GRT are required to have Certificates of Financial Responsibility (COFR) - see 33 CFR 138.10. The Coast Guard no longer issues COFRs. If the vessel owner and operator are not the same, the operator must ensure that the original or copy of the demise charter-party is maintained on board the vessel and made available upon request. The demise charter-party may be substituted by a written document on the owner’s letterhead, signed by the vessel owner, which specifically identifies the vessel operator named on the COFR – see 33 CFR 138.100.

**Items to check:**

- Records contain required info:
  - Name of each person currently designated as a person in charge of transfer operations.

- Date and result of the most recent test and inspection of each item tested or inspected required by 33 CFR 156.170
- Hose information required by 33 CFR 154.500(e) and (g) unless that information is marked on the hose
- Hoses in oil service properly marked:
  - Maximum allowable working pressure
  - Date of manufacture (may be recorded in the hose records)
  - Date of the latest test required by 33 CFR 156.170 (may be recorded in the hose records)
- Spill containment system at hose connections, vents and fills
- If vessel is 26 feet or greater in length, Oil pollution placard posted
- If vessel is equal to or greater than 100 GRT has either:
  - An approved oily-water separating equipment for the processing of oily mixtures from bilges or fuel oil tank ballast; or,
  - Pumping, piping and discharge equipment that:
    - At least one pump installed to discharge oily mixtures through a fixed piping system to a reception facility
    - At least one piping system outlet that is accessible from the weather deck
    - Shore connection(s) at each outlet that is compatible with reception facilities in the ship's area of operation
    - A stop valve for each outlet
    - For oceangoing vessels only:
      - If the vessel goes on international voyages, outlet(s) have a shore connection that meets the specifications in §155.430, or the ship has at least one adapter that meets the specifications in §155.430 and fits the required outlet(s)
      - A means on the weather deck near the discharge outlet to stop each pump that is used to discharge oily mixtures
- For vessels with a capacity of 250 barrels (10,500 gallons):
  - Declaration of Inspection(s) properly completed and retained for at least 1 month from date of signature as required by 33 CFR 156.150
  - Oil transfer procedures:
    - Available for inspection
    - Legibly printed in a language or languages understood by personnel engaged in transfer operations
    - Permanently posted or available at a place where the procedures can be easily seen and used by members of the crew when engaged in transfer operations.
    - Contents complete:
      - A list of each product transferred to or from the vessel
      - A description of each transfer system on the vessel:
        - A line diagram of the vessel's transfer piping, including the location of each valve, pump, control device, vent, and overflow
        - The location of the shutoff valve or other isolation device that separates any bilge or ballast system from the transfer system
      - A description of and procedures for emptying the discharge containment
    - Number of persons required to be on duty during transfer operations
    - Duties of each officer, person in charge, tankerman, deckhand, and any other person required transfer operations
    - Procedures and duty assignments for tending the vessel's moorings during the transfer operations;
    - Procedures for operating the emergency shutdown and communications means
    - Procedures for topping off tanks;
    - Procedures for ensuring that all valves used during the transfer operations are closed upon completion of transfer
    - Procedures for reporting discharges into the water

## **Pollution Prevention Equipment**

**Regulatory Cites:**

33 CFR 138.10 Scope (COFR)  
33 CFR 138.100 Non-owning operator's responsibility for identification  
33 CFR 151.10 Control of oil discharges  
33 CFR 154.500 Records  
33 CFR 155.320 Fuel oil and bulk lubricating oil discharge containment  
33 CFR 155.410 Pumping, piping and discharge requirements for non-oceangoing ships of 100 gross tons and above  
33 CFR 155.420 Pumping, piping and discharge requirements for oceangoing ships of 100 gross tons and above but less than 400 gross tons  
33 CFR 155.450 Placard  
33 CFR 155.720 Transfer procedures  
33 CFR 155.740 Availability of transfer procedures  
33 CFR 155.750 Contents of transfer procedures  
33 CFR 155.770 Draining into bilges  
33 CFR 155.800 Transfer hose  
33 CFR 156.150 Declaration of inspection  
33 CFR 156.170 Equipment tests and inspections

**Additional Guidance:**

Marine Safety Manual Volume II

# Security

## Cybersecurity

With maritime operations becoming more reliant upon automated systems, cyber risk is an increasing concern within the Marine Transportation System (MTS). Work Instruction CVC-WI-027 provides guidance on how the U.S. Coast Guard will assess the cyber risk on vessels to minimize risk to the MTS.

The USCG recognizes that not all towing companies and towing vessels are alike. If utilized, a safety management system (SMS) provides a towing company with the ability to tailor a structured system to address evolving cybersecurity vulnerabilities unique to a company and its vessels. A SMS established under the ISM Code is required to address cyber risks. Section D.1.h.3.t of CVC-WI-004 - *U.S. Flag Interpretations on the ISM Code* addresses emergency preparedness specifically states, "At a minimum the following risks should be evaluated and appropriate procedures established to respond: Piracy/Terrorism/Cyber Attacks". As such, ISM companies, either subject to the ISM Code or voluntarily complying, are required to implement procedures addressing cyber-attacks. In accordance with CVC-WI-027, companies have until their 2021 DOC audit to demonstrate implementation of the requirement. CVC-WI-027 also provides guidance on how to assess cyber risk management onboard non-SMS U.S. vessels.

### Regulatory Cites:

[33 CFR 104.305\(d\)\(2\)\(v\) and \(vi\)](#)

### Additional Guidance:

[CVC-WI-004](#) - U.S. Flag Interpretations on the ISM Code

[CVC-WI-027](#) - Vessel Cyber Risk Management Work Instruction

## MTSA and ISPS

MTSA applicability for towing vessels is based on the MTSA status of barges being towed. The ISPS Code applies to vessels on international voyages. Because MTSA includes ISPS requirements, compliance with MTSA satisfies ISPS requirements for U.S. vessels on an international voyage.

MTSA is applicable to all towing vessels greater than 26 feet in length engaged in towing a barge or barges subject to 46 CFR subchapters D or O. MTSA is also applicable to towing vessels that engage in towing a barge or barges that carry certain dangerous cargo in bulk that are subject to 46 CFR subchapter I. The above MTSA applicability does not apply to a towing vessel that temporarily assists another vessel engaged in towing a barge or barges, shifts a barge or barges at a facility or within a fleeting facility, assists sections of a tow through a lock, or provides emergency assistance.

Towing vessels subject to MTSA must be operated in accordance with their approved Vessel Security Plan (VSP) or Alternate Security Program (ASP) at all time. The VSP or ASP may include variable security measures to cover towing operations that don't involve barges subject to MTSA. Security plan approval is valid for five years from the date of approval. VSPs and ASPs must have an initial verification upon plan approval, and verification once in five years by the Coast Guard.

**Regulatory Cites:**

33 CFR 160.204 Exemptions and exceptions  
33 CFR 104.105 Applicability – towing vessels  
33 CFR 104.120 Compliance documentation  
33 CFR 104.410 Submission requirements

**Additional Guidance:**

NVIC 4-03 change 3 Guidance for verification of vessel security plan

# Towline and Terminal Gear

## Introduction

46 CFR Part 140, Subpart H (Towing Safety) requires that all components of the towing arrangement be adequate for their intended use, that pre-departure inspections of the towing equipment are performed, and that specific records regarding the towing equipment components are maintained. Construction characteristics and condition of all towing components must be appropriately matched to the horsepower or bollard pull ratings of the towing vessel and considerations of loads applied to the towing gear during intended service must be performed. Pre-departure inspections of all towing equipment, proper cargo stowage aboard the tow, and confirmation that the towing vessel's maneuverability characteristics are appropriately matched to the tow for the intended voyage are also required. The pre-departure inspections tie directly into the navigation assessment requirements of 46 CFR 140.635 where recordkeeping requirements specify that all tow equipment examinations performed be recorded. Records containing the characteristics (type, size, service use) of each towline must be maintained and available for review by the Coast Guard or third party auditor. Log entries linking the inspections to recordkeeping must be entered into the official logbook, Towing Vessel Record or as prescribed by the towing vessel's TSMS. Certain towing vessels also fall under the towing safety requirements of 33 CFR 163 and 164.

### Regulatory Cites:

[33 CFR 163](#) Towing of Barges  
[33 CFR 164](#) Navigation Safety Regulations  
[46 CFR 140.635](#) Navigation assessment  
[46 CFR 140.801](#) Towing gear  
[46 CFR 140.805](#) Towing safety  
[46 CFR 140.820](#) Recordkeeping for towing gear

## Recordkeeping for Towing Gear

Records of towline, towing gear and terminal gear inspections/examinations must be recorded in the Towing Vessel Record (TVR), official logbook or IAW the vessels approved TSMS. Towing gear used in conjunction with towing astern must meet the recordkeeping requirements of 33 CFR 164.74.

The recordkeeping requirements for face wires and spring lines used for towing ahead or pushing alongside include only the wires or lines which connect the towing vessel to the tow by means of stationary rigging.

### Items to check:

- Records of towing gear contain required information:
  - Results of inspections/examinations documented
  - Dates of inspections/examinations
  - Identification of each item inspected/examined
  - Name(s) of the person(s) who conducted the inspection/examination
- A record of the type, size and service of each towline, face wire, and spring line used to make the tow vessel fast to the tow.

## Regulatory Cites:

33 CFR 164.74 Towline and terminal gear for towing astern

33 CFR 164.76 Towline and terminal gear for towing alongside and pushing ahead

46 CFR 140.820 Recordkeeping for towing gear

46 CFR 140.915 Items to be recorded

## Terminal Gear

The owner, master, or operator of each vessel towing astern must ensure that the gear used to control, protect, and connect each towline meets the following criteria:

- Material and size of the terminal gear are appropriate for the strength and anticipated loading of the towline and for the environment
- Each connection is secured by at least one nut with at least one cotter pin or other means of preventing its failure
- The lead of the towline is appropriate to prevent sharp bends in the towline from fairlead blocks, chocks, or tackle
- Mechanical or non-mechanical method(s) to easily release the towline do not endanger operating personnel
- Towline is protected from abrasion or chafing by chafing gear, lagging, or other means.

### Thimble clip

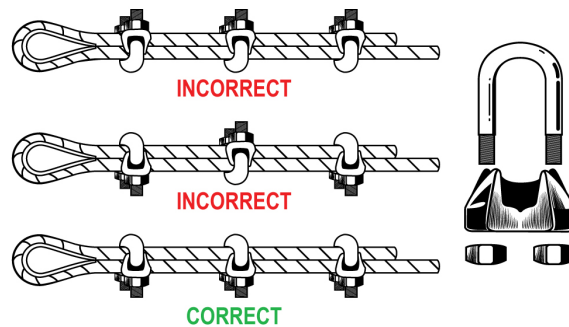

Diameter of Rope Inches	No. Clips for Each Rope End*
3/16	3
1/4	3
5/16	3
3/8	3
7/16	3
1/2	3
5/8	3
3/4	3
7/8	4
1	5
1-1/8	5
1-1/4	6
1-3/8	6
1-1/2	6
1-5/8	6
1-3/4	6
2	6

Number of Clips

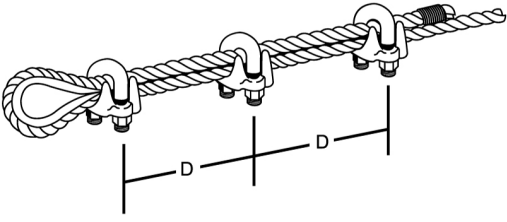

D = 6 times rope diameter  
Clip Spacing

### Spelter socket

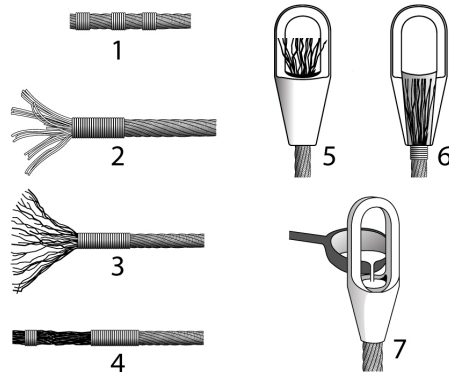
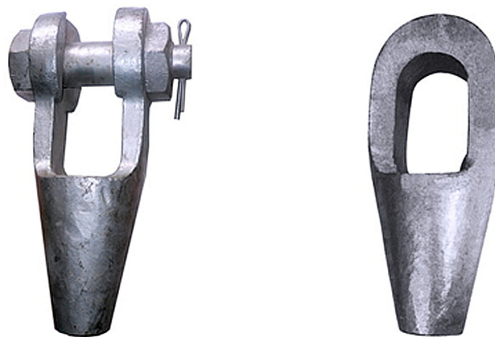

### Towline and Terminal Gear



### Astern barge make up

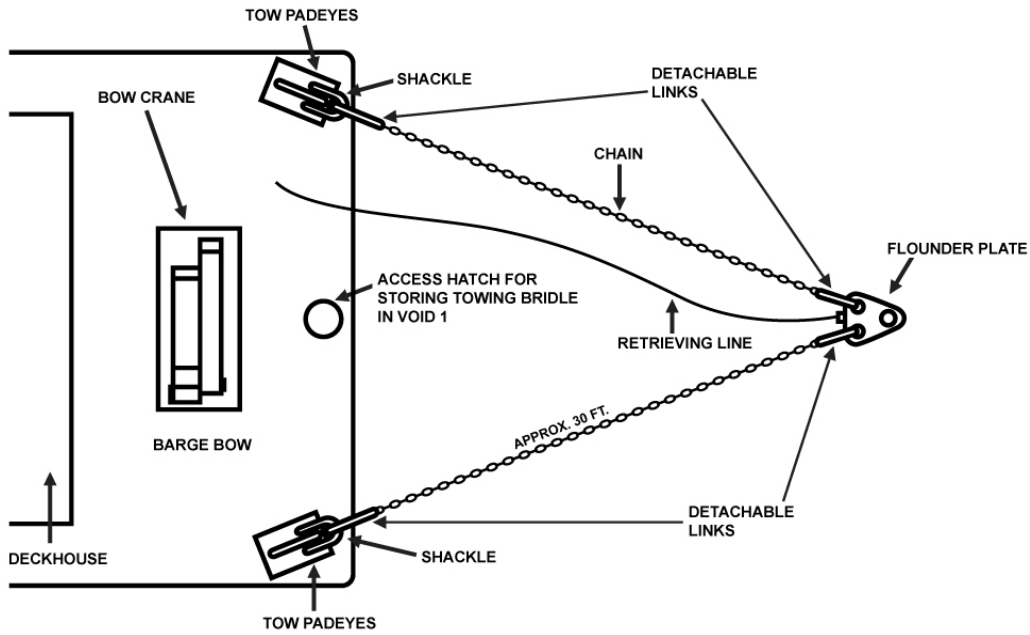

### Chafing gear arrangement

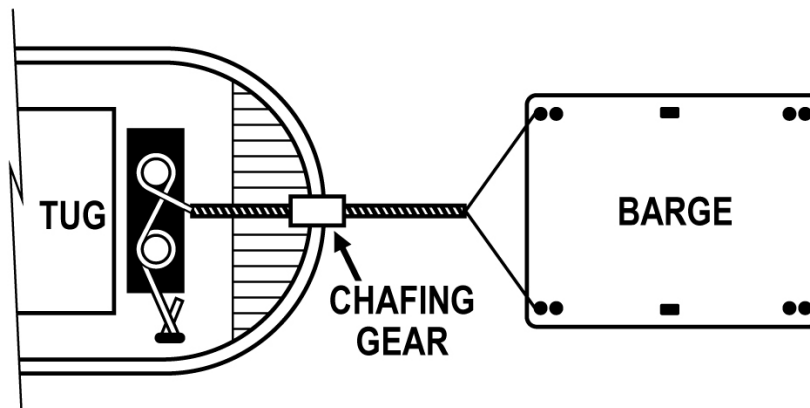

#### Items to check:

- Connections are secured by at least one nut with cotter pin or other means
- Lead is appropriate to prevent sharp bends
- Means of quick towline release
- Towline protected from chafing
- Fitted with a winch (Not required on a vessel towing in ice on Western Rivers or using a towline of synthetic or natural fiber)
- If fitted with winch drum, has a drum brake of adequate holding power

#### Towline and Terminal Gear

## **Regulatory Cites:**

33 CFR 164.74 Towline and terminal gear for towing astern

46 CFR 140.801 Towing Gear

## **Towing Gear**

When selecting a towing system, for pushing ahead, towing alongside or towing astern no one size fits all. The rigging, wire and lines required will vary in size composition, construction and strength depending on the towing methodology, dynamic loading and the environment in which it is used.

Breaking strength is the average force at which a product, in the condition it would leave the factory, has been found by representative testing to break, when a constant increasing force is applied in direct line to the product at a uniform rate of speed on a standard pull testing machine. It should be understood that breaking strength, when published by the supplier was obtained in a laboratory under conditions which are almost always impossible to duplicate in actual use.

When choosing wire rope, synthetic and natural fiber lines, and cables, a design or safety factor should be computed by dividing the computed breaking strength by the stated working load, expressed as a ratio. For example 5 to 1, which is a ratio commonly referred to as the safe working load. The safe working load is generally thought of as no more than 1/5 of the lines breaking strength. In other words the wire rope should be 5 times stronger than the expected load. Always use manufacturers breaking strength when available to calculate the safe work load.

The owner, operator, and master should ensure that lines and wires are properly installed so as to guard against damage while in use. They should also identify inspection and retirement criteria and insure that these are communicated to the crew. Crew training on proper care, handling and repair of towing gear should also be addressed.

Tests and inspections of towing gear must occur before the vessel embarks on a voyage of more than 24 hours or when each new master or operator assumes command:

- Visual inspection of tackle
- Connections of bridle and towing pendant, if applicable

## Typical Rope Damage



A wire rope which has jumped a sheave



A rope failing from fatigue after bending over small sheaves



Rope break due to excessive strain

## Wire diameter measurement

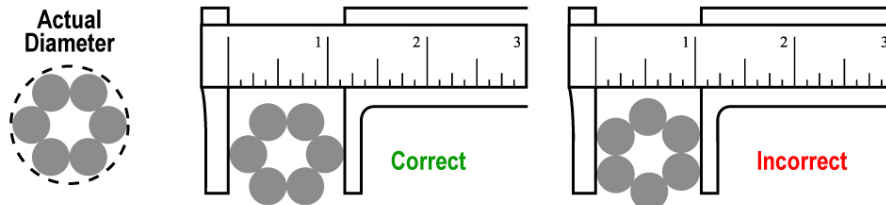

Rope Diameter (Inches)	Maximum Allowable Nominal Diameter Reduction (Inches)
5/16 and smaller	1/64
3/8 to 1/2	1/32
9/16 to 3/4	3/64
7/8 to 11/8	1/16
11/4 to 11/2	3/32
19/16 to 2	1/8
2 to 2-1/2	5/32

## Towline and Terminal Gear

- Procedures addressing emergency situations related to the tow, i.e. lost barge retrieval, are to be developed, and crews are to be properly trained accordingly.

**Barge recovery**

approaching the barge from either upwind or downwind, dragging the Nylon across the surge chain.

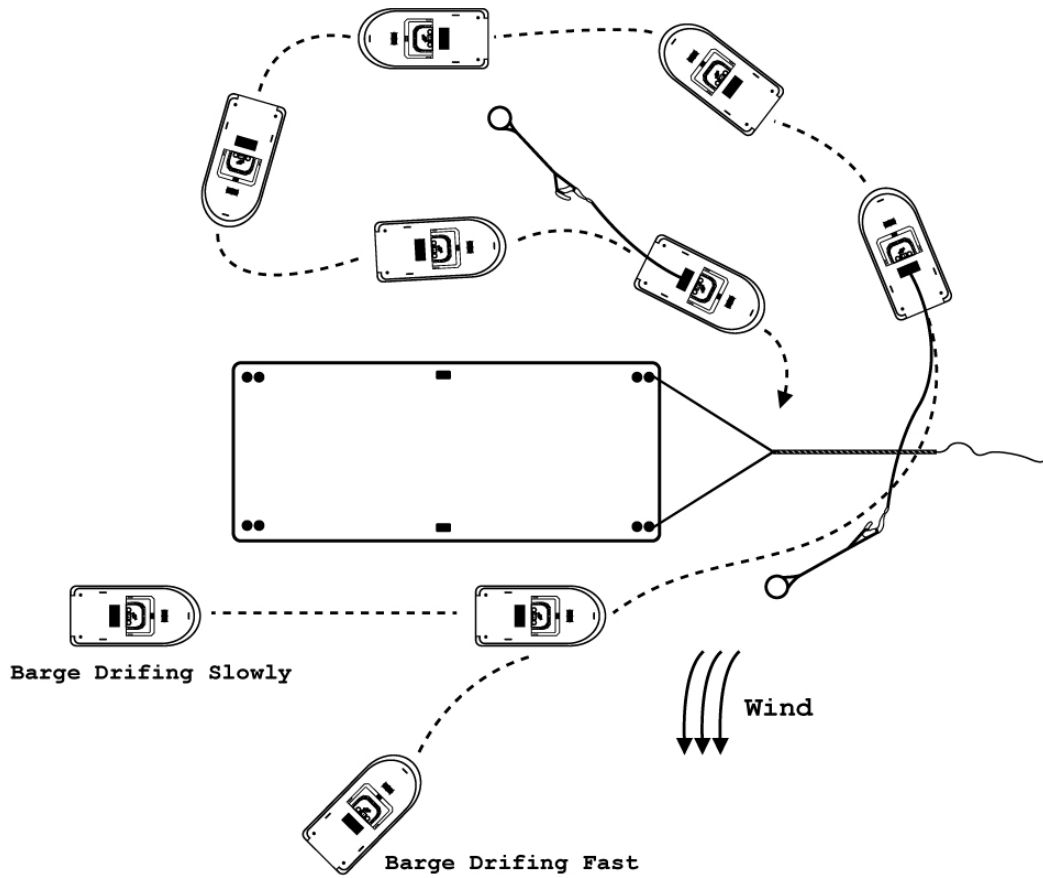

**Barge recovery low speed approach**

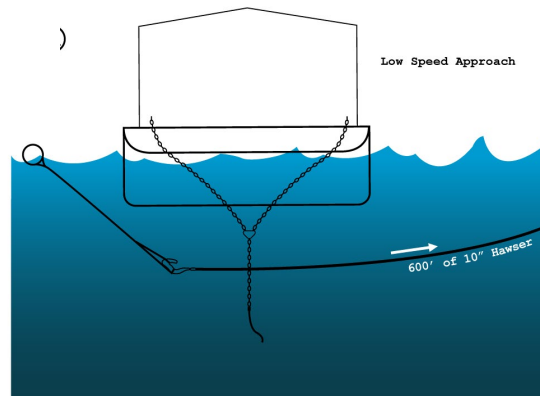

**Barge recovery higher speed approach**

**Towline and Terminal Gear**

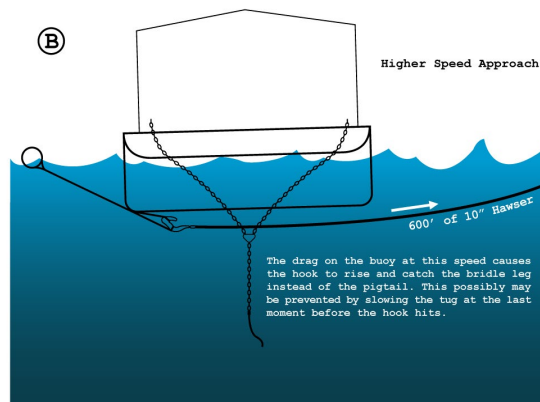

### Items to check:

- Strength of each component adequate for intended service
- Size, material and condition of tows, lines, wires, push gear, cables and other rigging appropriate
- Emergency procedures related to the tow / barge retrieval in place and provided to the crew

### Regulatory Cites:

33 CFR 164.80 Tests, inspections, and voyage planning

46 CFR 140.615 Examinations and tests

46 CFR 140.801 Towing gear

### Towline

The owner, master, or operator of each vessel towing astern must ensure that the strength of each towline is adequate for its intended service, considering at least the following factors:

- The size and material of each towline being appropriate for the vessel horsepower or bollard pull
- Static and dynamic loads expected during the intended service
- Sea conditions expected during the intended service
- Exposure to the marine environment and any chemicals used or carried on board the vessel
- Temperatures of normal stowage and service on board the vessel
- Likelihood of mechanical damage
- Compatibility with associated navigational-safety equipment.

Each towline must be rigged free of knots; spliced with a thimble, or have a poured socket at its end; and free of wire clips except for temporary repair, for which the towline must have a thimble and either five wire clips or as many wire clips as the manufacturer specifies for the nominal diameter and construction of the towline, whichever is more.

The condition of each towline must be monitored through records (kept on board the towing vessel or in company files) of the towline's initial minimum breaking strength as determined by the manufacturer, a classification society, or by a tensile test. Once a towline's record lapses for three months or more, except when a vessel is laid up or out of service or has not deployed its towline, the owner, master, or operator should retest the towline or remove it from service. Towlines purchased from another owner, master, or operator with the intent to use as a towline, or if a towline is retested for any reason, up-to-date records for the towline must be available for each retest of minimum breaking strength as determined by a

### Towline and Terminal Gear

classification society or a tensile test. Visual inspections of towlines should be made at least monthly, IAW with manufacturer's recommendations, or whenever the serviceability of the towline is in doubt.

**Items to check:**

- Towline as rigged is free of knots & spliced with thimble or poured socket
- Any temporary repairs made with thimble and minimum of five wire clips

**Regulatory Cites:**

[33 CFR 157.04](#) Authorization of classification societies

[33 CFR 164.74](#) Towline and terminal gear for towing astern

**Additional Guidance:**

API Specification 9A Specification for Wire Rope Section 3

ASTM D4268 Standard Test Methods for Testing Fiber Ropes

Cordage Institute CIA 3, Standard Test Methods for Fiber Rope Including Standard Terminations

[NVIC 5-92](#) Guidelines for Wire Rope Towing Hawsers

## **Towline and Terminal Gear**

The owner, master, or operator must ensure that the face wires, spring lines, and push gear used are:

- Appropriate for the vessel's horsepower
- Appropriate for the tow arrangement
- Frequently inspected
- Remain serviceable

**Items to check:**

- Face wires, spring lines & push gear appropriate, frequently inspected & serviceable.

**Regulatory Cites:**

[33 CFR 164.76](#) Towline and terminal gear for towing alongside and pushing ahead

# TPO (Third-Party Organizations) and TSMS (Towing Safety Management System)

## Third Party Organizations

Third Party Organizations (TPO) approved by the Coast Guard Towing Vessel NCOE (TVNCOE) are authorized to perform the functions listed in 139.115. Towing vessels intending on complying with the requirements found in Subchapter M by utilizing the Towing Safety Management System (TSMS) compliance option must obtain and maintain a TSMS Certificate from a TPO. Recognized and Authorized Class Societies are authorized under 139.110 to perform the work as a TPO without having to submit an application for approval.

The CG is responsible for the oversight of CG approved TPOs under Subchapter M as well as Recognized and Authorized Class Societies performing work related to Subchapter M.

### Items to check:

- TPO approval letter from CG TVNCOE
- TPO conformance with internal Quality Management System (QMS)
- TPO retained list of current and former auditors and surveyors
- Results of audits submitted to the TVNCOE
- Results of vessel/management audits and reports of surveys conducted
- Records of complaints regarding TPO
- MISLE history of vessels operating under a valid TSMS
- Results of TPO assessments conducted by the CG

### Regulatory Cites:

[46 CFR Part 8 Vessel Inspection Alternatives](#)  
[46 CFR 139.115 General](#)  
[46 CFR 139.120 Application for approval as TPO](#)  
[46 CFR 139.130 Qualifications of auditors and surveyors](#)  
[46 CFR 139.135 Addition and removal of auditors and surveyors](#)  
[46 CFR 139.165 Documentation](#)

### Additional Guidance:

[TVNCOE TPO Webpage](#)  
[CG-CVC Policy Letter 17-04 - Subchapter M Third Party Organization \(TPO\) Guidance](#)  
[CVC Work Instruction WI-005 – Request for Recognized Organization \(RO\) Internal QMS Review – “Quality Case”](#)  
[CVC Work Instruction WI-008 - Vertical Contract Audits](#)  
[Part 139 FAQs](#)

## Towing Safety Management Systems

The purpose of a Towing Safety Management System (TSMS) is to establish policies, procedures, and required documentation to ensure the owner or managing operator meets its established goals while ensuring continuous compliance with all regulatory requirements. Towing vessels utilizing the TSMS compliance option must be associated with a TSMS Certificate, issued by an approved Third Party Organization (TPO), and complete scheduled surveys and audits to verify compliance.

**Items to check:**

- Valid TSMS Certificate (or copy on board vessel)
- Verify applicable policies and procedures are available to the crew
- Crew knowledge of TSMS, ability to respond to emergencies
- Master's annual review of TSMS
- Completion of required audits
- Results of audits and corrective action process completion

**Regulatory Cites:**

46 CFR 138.210 Objectives of a TSMS  
46 CFR 138.215 Functional requirements of a TSMS  
46 CFR 138.220 TSMS elements  
46 CFR 138.310 Internal audits for a TSMS certificate  
46 CFR 138.315 External audits for a TSMS certificate  
46 CFR 138.405 Conduct of internal audits  
46 CFR 138.410 Conduct of external audits  
46 CFR 138.505 Submittal of external audit results

**Additional Information:**

CG-CVC Policy Letter 17-02 Use of Existing Safety Management Systems to Obtain an Initial Certificate of Inspection  
Part 138 FAQs  
CVC Work Instruction WI-003 – USCG Oversight of SMSs on U.S. Flag Vessels