

U.S.C.G. Merchant Marine Exam

QMED

Q806 Fireman – Watertender

(Sample Examination)

Choose the best answer to the following Multiple-Choice Questions:

1. On vessels exceeding 1600 GRT, who is responsible for the practical upkeep of machinery and the manning of the engine room?
- A. First assistant engineer
 - B. Chief mate
 - C. Chief engineer
 - D. Officer in charge of the engineering watch

Correct answer: A

2. During oil transfer operations, who would be responsible to guarantee that the posted transfer procedures are being followed?
- A. The designated person in charge
 - B. The tankerman
 - C. The oiler
 - D. The senior able seaman

Correct answer: A

3. In order for the automatic lifeboat drain to operate properly _____.
- A. the cap should be removed to drain the boat when it is waterborne
 - B. the cage must be free of rubbish or the ball may not seat properly
 - C. there is an automatic ball check located in a siphon tube
 - D. the small lever to release the rubber ball float must be turned counter-clockwise

Correct answer: B

4. In preparing the surface of a metal for application of primers and finish coats, which of the listed hand tools would be best used to clean up welds and other areas where there is pitting?
- A. Sandpaper
 - B. Wire brush
 - C. Chipping hammer
 - D. Hand scraper

Correct answer: B

5. Artificial respiration may be necessary in cases of _____.
- A. electrocution
 - B. poisoning
 - C. drowning
 - D. all of the above

Correct answer: D

6. By what criteria are hard hats (protective helmets) rated?
- A. They are rated by type as it applies to direction of impact protection, and they are rated by class of service as it applies to protection from exposure to electrical voltage.
 - B. They are rated by class of service as it applies to protection from exposure to electrical voltage only, such as no voltage, limited voltage, and high voltage protection.
 - C. They are rated by whether or not the headband is adjustable and by the length of the bill on the shell.
 - D. They are rated by type as it applies to direction of impact protection only, such as impacts from the top or impacts from the top and side.

Correct answer: A

7. A person manning a fire hose under pressure with an all-purpose nozzle attached, should be aware that the nozzle is most difficult to control when the handle position is changed from _____.
- A. shut to solid stream
 - B. low velocity to high velocity fog
 - C. fog to shut
 - D. solid stream to fog

Correct answer: A

8. Which of the following conditions is a symptom of heat stroke?
- A. cold and moist skin, high body temperature
 - B. hot and dry skin, high body temperature
 - C. hot and moist skin, high body temperature
 - D. cold and dry skin, low body temperature

Correct answer: B

9. While fires are lit in a boiler, in terms of uptake dampers and air register doors, what conditions must be met?
- A. All uptake dampers should be locked open, all air register doors on lit burners should be throttled according to the firing rate, and all air register doors on idle burners should be open.
 - B. All uptake dampers should be locked open, all air register doors on lit burners should be wide open or throttled, and all air register doors on idle burners should be closed.
 - C. All uptake dampers should be throttled according to the firing rate, all air register doors on lit burners should be wide open, and all air register doors on idle burners should be closed.
 - D. All uptake dampers should be throttled according to the firing rate, all air register doors on lit burners should be throttled according to the firing rate, and all air register doors on idle burners should be closed.

Correct answer: B

10. What type of wound is generally associated with no bleeding and is very susceptible to infection?
- A. Abrasion
 - B. Laceration
 - C. Incision
 - D. Puncture

Correct answer: D

11. When fighting a fire with a portable dry chemical extinguisher you should always _____.
- A. spray the chemical across the tops of the flames
 - B. attack the fire from the leeward side
 - C. bounce the chemical onto the fire from adjacent structural members
 - D. direct the stream of chemical toward the base of the fire

Correct answer: D

12. Back injuries are one of the most common injuries that result in lost work time. What is the proper technique for lifting an object?
- A. Bend the knees and grasp the object firmly. While keeping the back straight, lift the object by straightening the legs. Move the object while standing erect and keep object close to the body.
 - B. Bend over and grasp the object firmly. While keeping the legs straight, lift the object by straightening the back. Move the object while standing erect and keep object away from the body.
 - C. Bend over and grasp the object loosely. While keeping the legs straight, lift the object by straightening the back. Move the object while standing erect and keep object close to the body.
 - D. Bend the knees and grasp the object loosely. While keeping the back straight, lift the object by straightening the legs. Move the object while standing erect and keep object away from the body.

Correct answer: A

13. At a minimum threshold, how many milliamps of current through the body produces a painful sensation that most people would perceive as an electric shock?
- A. 3 to 7 mA
 - B. 10 to 16 mA
 - C. 30 mA
 - D. 100 mA for 2.5 sec.

Correct answer: A

14. Which of the following automatically actuates the overspeed tripping device installed on an auxiliary turbine?
- A. hydraulic pressure
 - B. centrifugal force
 - C. high back pressure
 - D. pneumatic force

Correct answer: B

15. When blowing tubes, what is the determining factor in deciding how many revolutions of rotation of a sootblower element are required?
- A. When the steam supply manifold drains blow clear
 - B. When the scavenging air indicator shows clear
 - C. Sootblower elements are never rotated more than one revolution
 - D. When the smoke indicator (periscope) shows clear

Correct answer: D

16. What type of valve would be fitted with a quarter-turn power actuator, such as a rack-and-pinion?

- A. Rising stem gate valve
- B. Butterfly valve
- C. Non-rising stem gate valve
- D. Globe valve

Correct answer: B

17. Which of the following statements is correct concerning heat transfer?

- A. Heat is given off from a high temperature region known as a heat sink.
- B. Heat transfer rate is affected most by the size of the heat sink involved.
- C. Heat transfer rate is affected most by the temperature difference between the heat source and the heat sink.
- D. Heat transfer by radiation will occur only by mass motion of a fluid substance.

Correct answer: C

18. An oxygen indicator will detect _____.

- A. an oxygen deficiency in a space
- B. concentrations of explosive gas
- C. the presence of harmful amounts of carbon monoxide
- D. all of the above

Correct answer: A

19. What is the purpose of the main steam stop bypass valve?

- A. cross-connect two steaming boilers
- B. isolate the main steam stop for repairs while steaming
- C. supply auxiliary steam when the main steam stop is closed
- D. gradually increase the pressure and temperature of the main steam piping when warming up

Correct answer: D

20. The property of a fuel oil which is a measurement of its available energy, is known as its _____.

- A. heating value
- B. viscosity index
- C. cetane index
- D. cetane number

Correct answer: A

21. What strategy for avoiding heat exhaustion is most likely to result in more severe pain as associated with heat cramps?

- A. Drinking excessive water lost during profuse sweating without replacing the salt lost
- B. Drinking insufficient water and taking in insufficient salt to replace that lost during profuse sweating
- C. Taking in excessive salt lost during profuse sweating without replacing the water lost
- D. Drinking excessive water and taking in excessive salt to replace that lost during profuse sweating

Correct answer: A

22. The atmospheric drain tank (ADT) normally drains to the _____.

- A. distillate tank
- B. reserve feed tanks
- C. main and/or auxiliary condenser
- D. main and/or auxiliary air ejector condenser

Correct answer: C

23. Which of the listed methods, is the most effective to fight a fire on the open deck of a vessel if using a dry chemical type fire extinguisher?

- A. Direct the extinguisher discharge at the base of the fire.
- B. Move the discharge stream back and forth in a rapid sweeping motion.
- C. Approach the fire from the windward side.
- D. All of the above.

Correct answer: D

24. In terms of the completeness of combustion, in performing a stack gas analysis on an operating boiler, what would be the indication of the LEAST complete combustion?

- A. Relatively high CO₂ percentage and relatively low CO percentage
- B. Relatively high CO₂ percentage and relatively high CO percentage
- C. Relatively low CO₂ percentage and relatively low CO percentage
- D. Relatively low CO₂ percentage and relatively high CO percentage

Correct answer: D

25. On US flag steam propulsion vessels, the main reason for having a low suction line on the fuel oil service or settling tanks is to accomplish which of the following?

- A. prevent loss of suction during rough weather
- B. decrease suction head on the pump
- C. increase the amount of fuel available for use
- D. facilitate water removal

Correct answer: D

26. With regard to the relative flow patterns through the tubes and the shell of single pass shell-and-tube heat exchangers, what statement is true?

- A. In a cross-flow heat exchanger, the flow through the tubes and the flow through the shell are in opposite directions.
- B. In a parallel-flow heat exchanger, the flow through the tubes and the flow through the shell are in opposite directions.
- C. In a counterflow heat exchanger, the flow through the tubes and the flow through the shell are in opposite directions.
- D. In a counterflow heat exchanger, the flow through the tubes and the flow through the shell are in the same direction.

Correct answer: C

27. A large oil fire on the weather deck of a ship can be effectively fought using _____.

- A. soda acid
- B. high velocity fog
- C. foam
- D. dry chemical

Correct answer: C

28. The component shown in the illustration, labeled "IV", is the _____. Illustration SE-0013

- A. first reduction gear
- B. bull gear
- C. high-speed pinion
- D. low-speed pinion

Correct answer: B

29. It is necessary to cool the bulkheads and decks surrounding a compartment where there is a fire in order to _____.

- A. cool the metal below its ignition temperature
- B. form a dense coating of smothering steam
- C. prevent the fire from spreading by the conduction of heat
- D. prevent oxygen from reaching the flames

Correct answer: C

30. The DC heater automatic level dump valve is used to _____.

- A. maintain a proper condensate level in the condenser hotwell
- B. divert excess feedwater to the distilled water tank
- C. recirculate condensate to the atmospheric drain tank
- D. divert the flow of condensate from the first stage heater to the vent condenser

Correct answer: B

31. In the system illustrated, what type of valves are downstream of point "A"? Illustration SG-0005

- A. globe valves/ gate valves
- B. stop-check/ stop valves
- C. swing check/ stop valves
- D. gauge valves/ drain valves

Correct answer: B

32. If an air compressor is used to supply air primarily to the combustion control system and other pneumatic controllers, the entire system is known as the _____.

- A. forced draft air system
- B. control air system
- C. supply air system
- D. ships service air system

Correct answer: B

33. You are about to enter a compartment to investigate a suspected smoldering fire. If you're not wearing a self-contained breathing apparatus, you should test the compartment's atmosphere to determine if there is/are _____.
- A. sufficient oxygen to sustain human life
 - B. a toxic atmosphere in the compartment
 - C. an explosive mixture in the compartment
 - D. all of the above

Correct answer: D

34. The most common cooling agent used for fighting fires on tank vessels is _____.
- A. carbon dioxide
 - B. steam smothering
 - C. water
 - D. flue gas

Correct answer: C

35. Under what circumstances could equipment be operated when tagged with DANGER tags?
- A. Whenever permission is granted by your supervisor
 - B. Whenever there is a break in the actual maintenance activity
 - C. Never
 - D. Whenever you feel that it is safe to do so

Correct answer: C

36. If a sea water-cooled shell-and-tube lubricating oil cooler has the sea water inlet and outlet connections on the opposite end waterboxes, in terms of the number of passes, what statement is true?
- A. The number of fluid passes cannot be determined.
 - B. The tube-side fluid flow pattern is single-pass.
 - C. The tube-side fluid flow pattern is four-pass.
 - D. The tube-side fluid flow pattern is two-pass.

Correct answer: A

37. When a boiler has been secured and is being initially cooled, the water level showing in the steam drum gauge glass should be _____.
- A. allowed to drop naturally
 - B. allowed to go out of sight
 - C. maintained at the normal level
 - D. maintained at a full glass

Correct answer: C

38. Which of the following methods is preferred by regulatory agencies, to reduce the possibility of producing an electrical spark when taking bunkers?

- A. Connecting a bonding wire between the shoreside piping and the vessel
- B. Using a cargo hose with a built-in electrical bonding wire
- C. Placing an insulating flange or a section of non-conducting hose in the hose setup
- D. Using a metal jacketed fueling hose with rubber gaskets

Correct answer: C

39. Steam supplied to the main propulsion turbines is _____.

- A. desuperheated steam
- B. superheated steam
- C. wet steam
- D. saturated steam

Correct answer: B

40. Which of the methods shown in the illustration is the correct way to fit shoring? Illustration SF-0016

- A. A
- B. B
- C. C
- D. D

Correct answer: A

41. A coolant is usually used when cutting metal in a power hacksaw to prevent the _____.

- A. cut from clogging
- B. blade from bending
- C. blade from catching on the work piece
- D. blade from overheating

Correct answer: D

42. A chisel with a mushroom head should not be used because _____.

- A. it must be held firmly by the head to strike it
- B. pieces may fly off the chisel and injure your eyes
- C. the hammer head may be chipped
- D. the chisel cannot be struck squarely

Correct answer: B

43. Taps and dies used for threading pipe, under U.S. standards, are _____.

- A. straight
- B. tapered
- C. not fluted
- D. not hardened

Correct answer: B

44. How is solid trash and garbage generally admitted to a solid-waste incinerator on most ships?
- A. The trash is admitted manually via a loading door.
 - B. The trash is admitted via a chute.
 - C. The trash is admitted via a ram feed system.
 - D. The trash is admitted via a screw feed system.

Correct answer: A

45. The leakage of air into the pump casing by way of the packing gland of a condensate pump, is prevented by _____.
- A. a water seal line to the packing gland
 - B. an air seal line from the compressed air line
 - C. special packing in the stuffing box
 - D. the vacuum in the pump suction

Correct answer: A

46. The pressure in the feedwater system must exceed boiler steam drum pressure in order to _____.
- A. force the feedwater into the boiler
 - B. prevent water hammer in the lines
 - C. remove the steam from the steam drum
 - D. prevent air leakage into the feedwater system

Correct answer: A

47. An eroded globe valve disk can be repaired by _____.
- A. scraping with a bastard file
 - B. sandblasting with lightweight grit
 - C. taking a light cut in a lathe
 - D. dressing the seat with crocus cloth

Correct answer: C

48. Fuel oil settling tanks are used to _____.
- A. store oil for immediate use
 - B. facilitate the stripping of sludge and water
 - C. precipitate out water and solids
 - D. all of the above

Correct answer: D

49. What communications system would be operational despite a loss of ship's electrical power?
- A. Call-bell system
 - B. Sound-powered telephone system
 - C. Ship's service telephone system
 - D. Emergency loudspeaker system

Correct answer: B

50. Which of the following procedures reduces the possibility of an interior ventilation duct fire from rapidly spreading?

- A. Keeping the duct interior clean
- B. Keeping the duct exterior clean
- C. Having a fire hose charged at each duct opening
- D. Having a portable CO₂ ready at each duct opening

Correct answer: A

51. At a minimum threshold, how many milliamps of current through the body produces a condition where most people would experience respiratory paralysis and be unable to breathe while still in contact with the energized conductor?

- A. 3 to 7 mA
- B. 10 to 16 mA
- C. 30 mA
- D. 75 mA for 5 sec.

Correct answer: C

52. Fuel oil day tanks for diesel engines must be checked and cleaned at regular intervals in order to remove _____.

- A. micro-organism growth
- B. water
- C. sludge
- D. all of the above

Correct answer: D

53. Petroleum vapors are dangerous _____.

- A. at all times due to their toxicity
- B. only if the vapor is between the upper and lower explosive limit
- C. only if the oxygen concentration is below 16 percent
- D. only if the source of the vapor is above its flash point

Correct answer: A

54. As shown in the illustrated D type single furnace boiler, what does item "E" represent? Illustration SG-0008

- A. Support tubes
- B. Riser tubes
- C. Downcomer tubes
- D. Upcomer tubes

Correct answer: C

55. What statement is true regarding the reading of a liquid filled manometer?

- A. The reading should be taken at the center of the curved surface of the meniscus, regardless whether the manometer is water-filled or mercury-filled.
- B. Water does not wet the glass; therefore, the reading should be taken at the top of the meniscus on water-filled manometers.
- C. The reading should be taken at the edges of glass contact of the curved surface of the meniscus, regardless whether the manometer is water-filled or mercury-filled.
- D. Mercury wets the glass; therefore, the reading should be taken at the top of the meniscus of mercury-filled manometers.

Correct answer: A

56. Which of the valves listed for the device shown in the illustration will be open while the unit is operating in the backflush mode? Illustration GS-0153

- A. valve "4"
- B. valves "4" and "5"
- C. valves "4" and "14"
- D. valves "4", "5", and "14"

Correct answer: C

57. Which health hazard term is listed on a Safety Data Sheet (SDS) to indicate that contact with the substance will freeze body tissue on contact?

- A. Cryogenic
- B. Freeze hazard
- C. Freon hazard
- D. Cyanosis

Correct answer: A

58. In order for microbiological growths to thrive in a fuel tank it is necessary for _____.

- A. vanadium to be present
- B. low temperatures to exist
- C. moisture or water to be present
- D. electrolysis to be occurring

Correct answer: C

59. What statement best represents the characteristics of an innage tape and bob for the purposes of taking a vented tank sounding?

- A. The bob has a cupped end and sinks in the liquid when lowered by the tape.
- B. The bob has a pointed end and floats on the surface of the liquid when lowered by the tape.
- C. The bob has a pointed end and sinks in the liquid when lowered by the tape.
- D. The bob has a cupped end and floats on the surface of the liquid when lowered by the tape.

Correct answer: C

60. Your ship has run aground and it is necessary to determine whether or not a compartment has flooded. Therefore, you should _____.
- A. open the watertight door and take a quick look
 - B. feel the bulkhead to see if it is hot
 - C. tap the bulkhead with a hammer to check for a water level
 - D. open the hatch dogs on the side away from the hinges

Correct answer: C

61. What type of fuel oil as part of an oily-water mixture is most likely to have a density approaching that of water?
- A. Distillate/residual fuel oil blends
 - B. Marine diesel oil
 - C. Light distillate oil
 - D. Heavy residual fuel oil

Correct answer: D

62. After which of the following is the air cock to be closed when raising steam on a cold boiler?
- A. steam has formed and all air is vented
 - B. all burners have been lit and firing normally
 - C. the boiler is cut in on the line
 - D. the economizer drain is closed

Correct answer: A

63. If you wish to initiate a station-to-station call over a sound-powered telephone circuit, what is the correct procedure?
- A. Select the station you are calling from with the rotary selector switch, turn the hand-crank a few revolutions, depress the button on the handset, and listen for your party to answer the call.
 - B. Select the station you wish to call with the rotary selector switch, depress the button on the handset, and listen for your party to answer the call.
 - C. Select the station you wish to call with the rotary selector switch, turn the hand-crank a few revolutions, and listen for your party to answer the call.
 - D. Select the station you wish to call with the rotary selector switch, turn the hand-crank a few revolutions, depress the button on the handset, and listen for your party to answer the call.

Correct answer: D

64. Remote valve operators are frequently fitted with a handwheel for local operation if the motor fails. If this is so, what is the procedure for local manual control?
- A. First move the lever to engage the motor clutch, then rotate the handwheel.
 - B. Just rotate the handwheel in the appropriate direction for valve operation.
 - C. First move the lever to disengage the motor clutch, then rotate the handwheel.
 - D. Motor operated valves are generally not fitted with local handwheels.

Correct answer: C

65. Which of the listed devices would be installed in the air compressor discharge line between the compressor and receiver of a control air system?

- A. Moisture separator
- B. P-I converter
- C. Lubricator
- D. Vacuum breaker

Correct answer: A

66. Condensate return lines from tank heating coils are led to the _____.

- A. main condenser
- B. atmospheric drain tank
- C. DC heater
- D. contaminated drain system

Correct answer: D

67. While adrift in an inflatable life raft in hot, tropical weather _____.

- A. the canopy should be deflated so that it will not block cooling breezes
- B. the pressure valve may be periodically opened to prevent excessive air pressure
- C. deflating the floor panels may help to cool personnel
- D. the entrance curtains should never be opened

Correct answer: C

68. Item 4 shown in the illustration represents a _____. Illustration GS-0125

- A. manifold
- B. suction line
- C. bilge system
- D. vacuum branch line

Correct answer: A

69. An excess pressure governor is a special type of control device. On what equipment would an excess pressure governor normally be found?

- A. forced draft fan
- B. turbine-driven feed pump
- C. main circulator pump
- D. low-pressure propulsion turbine

Correct answer: B

70. By which of the listed methods may heat be transferred from one body to another?

- A. Radiation
- B. Convection
- C. Conduction
- D. All of the above

Correct answer: D

GS-0125

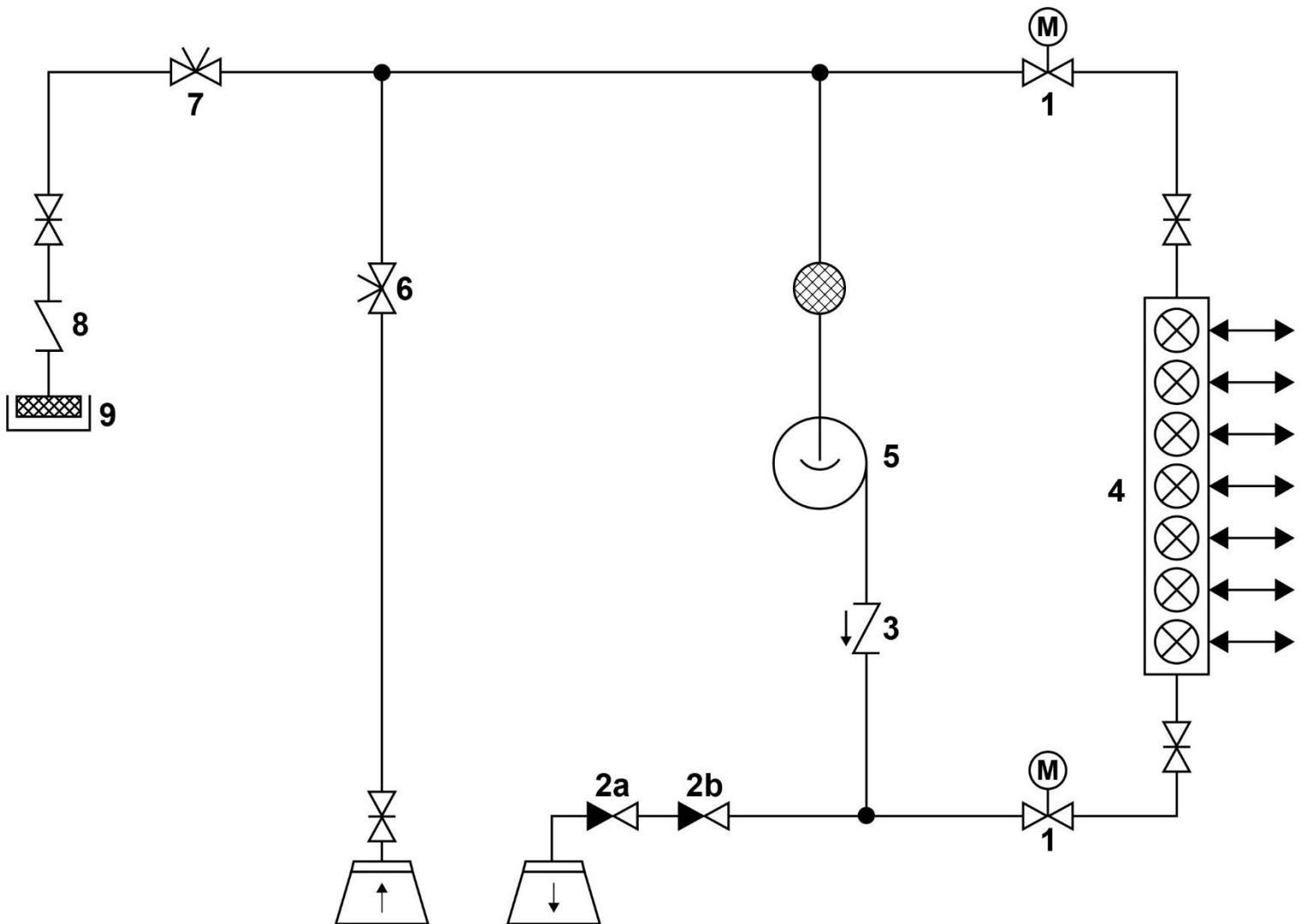

Adapted for testing purposes only
Further reproduction prohibited without permission

GS-0153

Control Room

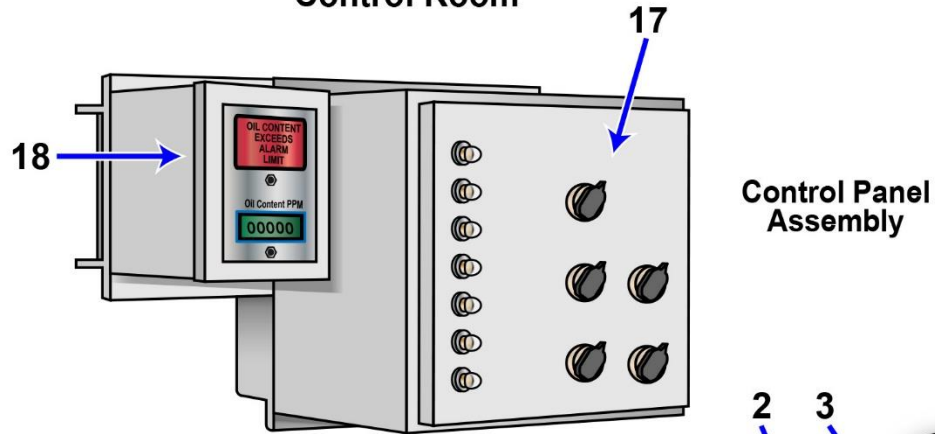

Engine Room

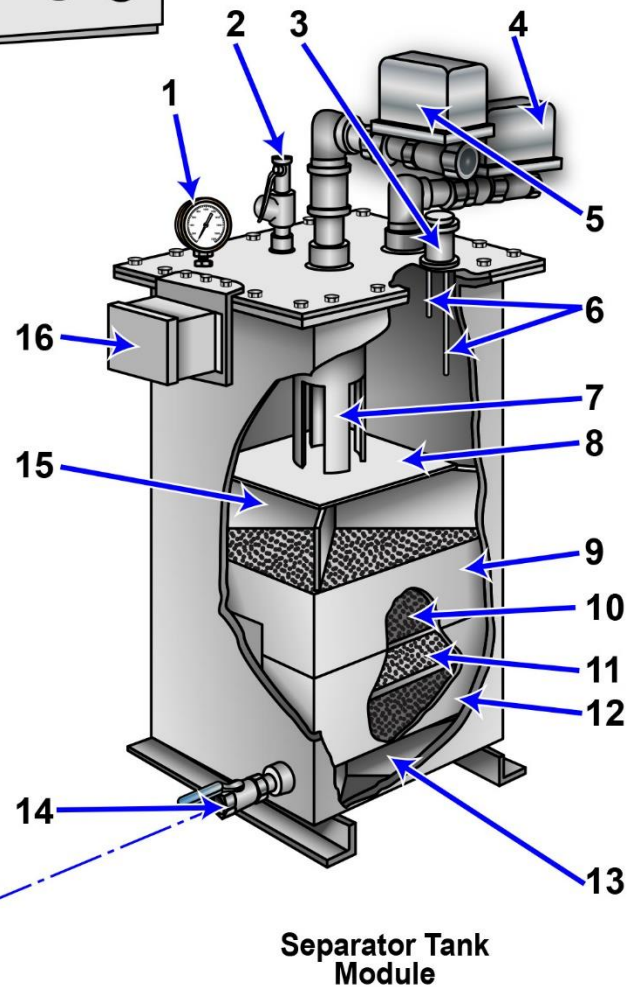
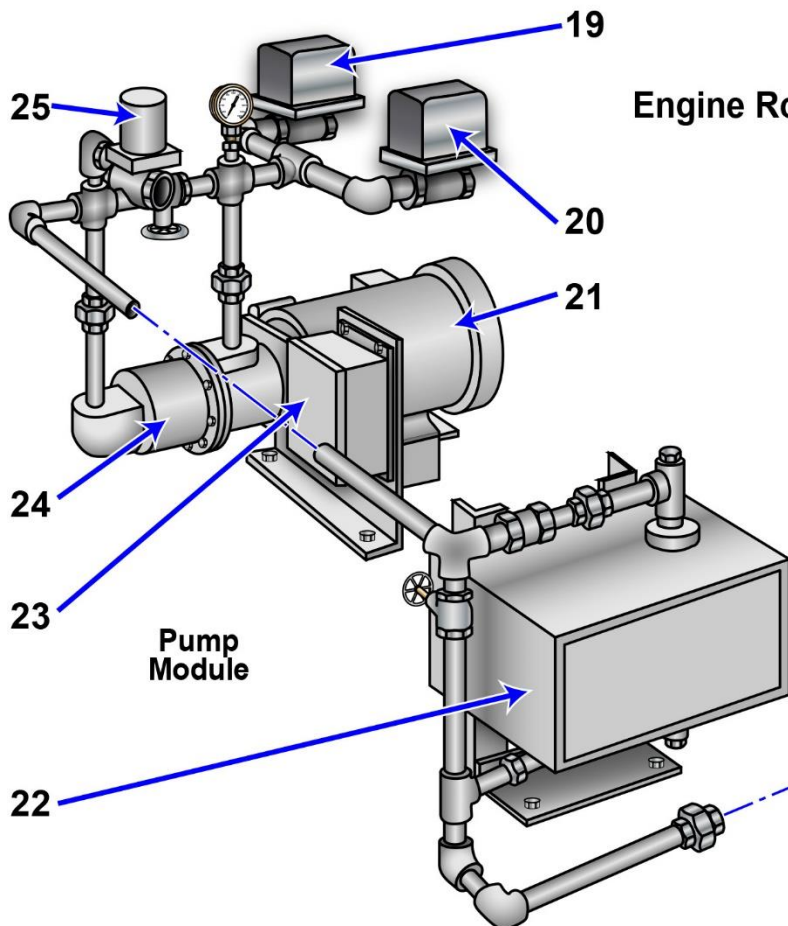

Adapted for testing purposes only from Operator, Unit and Direct Support Maintenance Manual Including
Repair Parts and Special Tools List for Oil Water Separator
TM 55-1925-285-13 & P
Further reproduction prohibited without permission

SE-0013

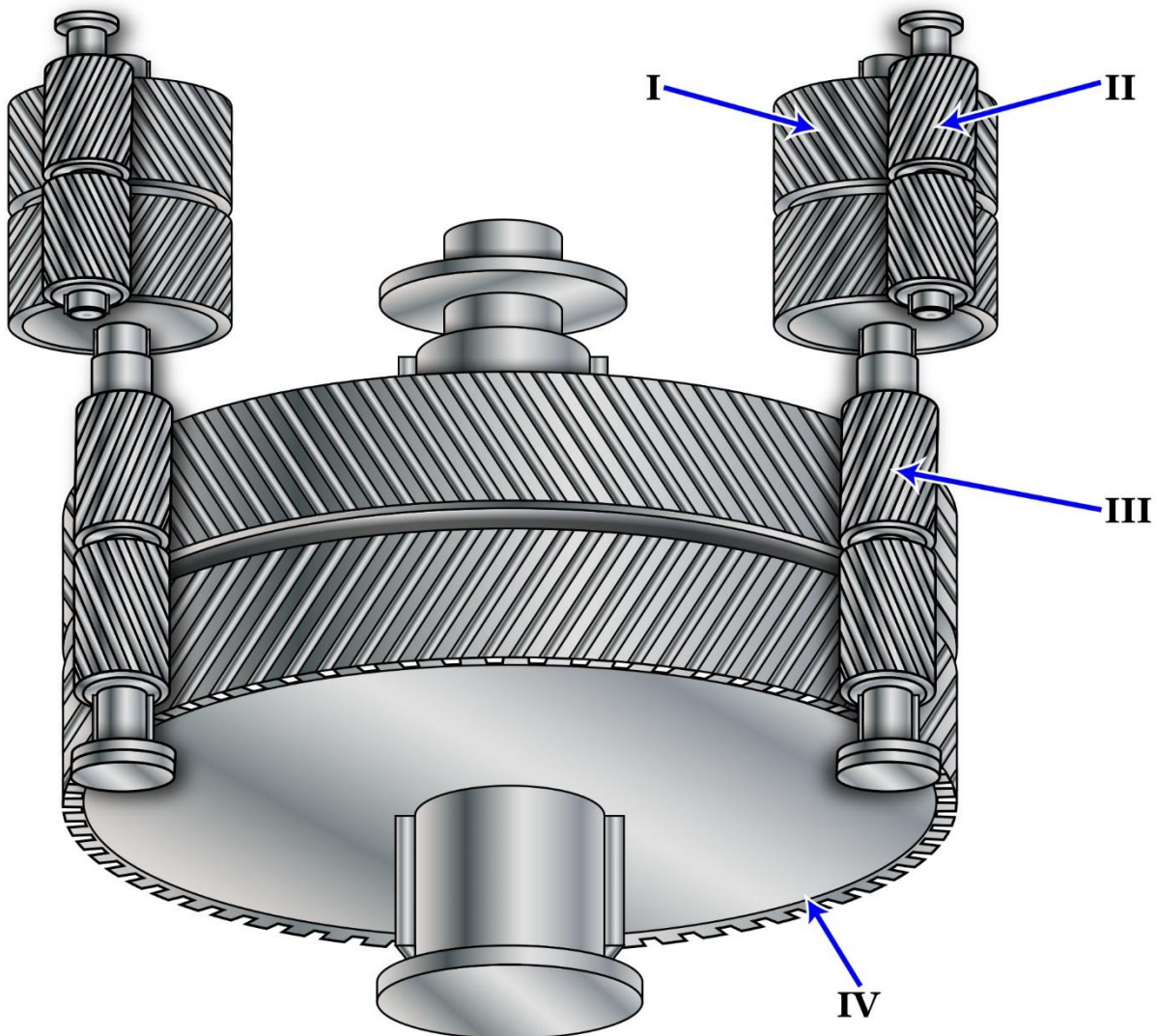

Adapted for testing purposes only from HARRINGTON, Marine Engineering
Copyright © 1992 by the Society of Naval Architects and Marine Engineers
Further reproduction prohibited without permission

SF-0016

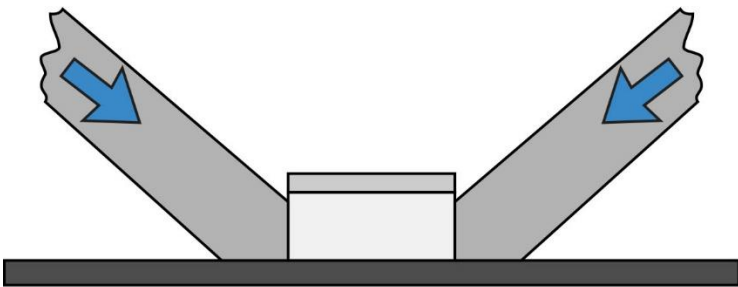

A

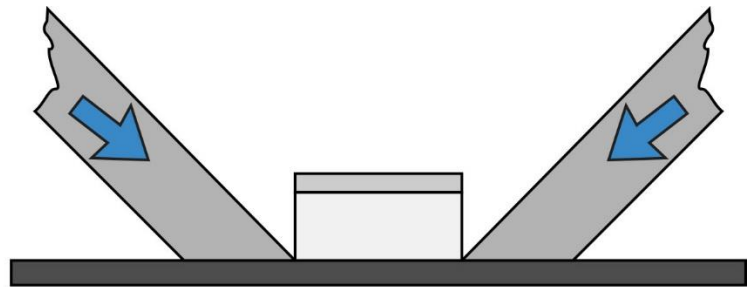

B

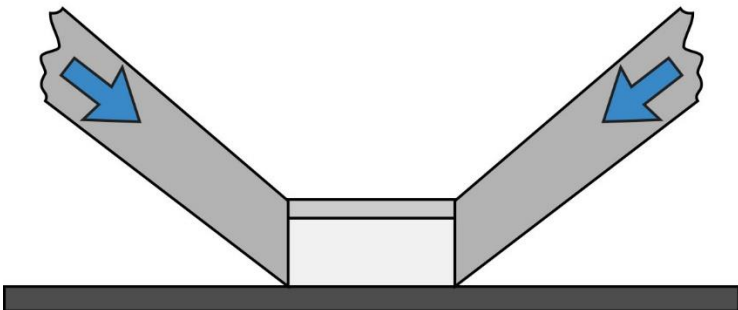

C

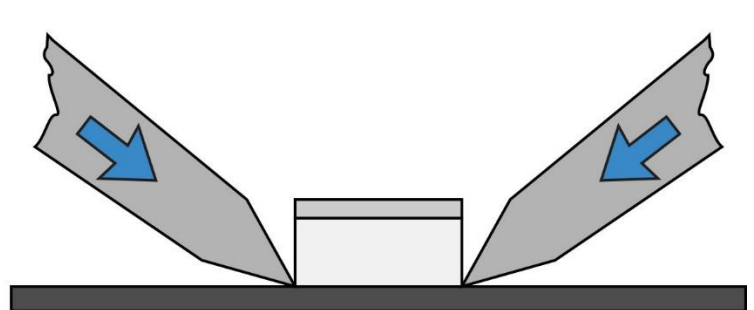

D

Adapted for testing purposes only from Damage Controlman
NAVEDTRA 14057
Further reproduction prohibited without permission

SG-0005

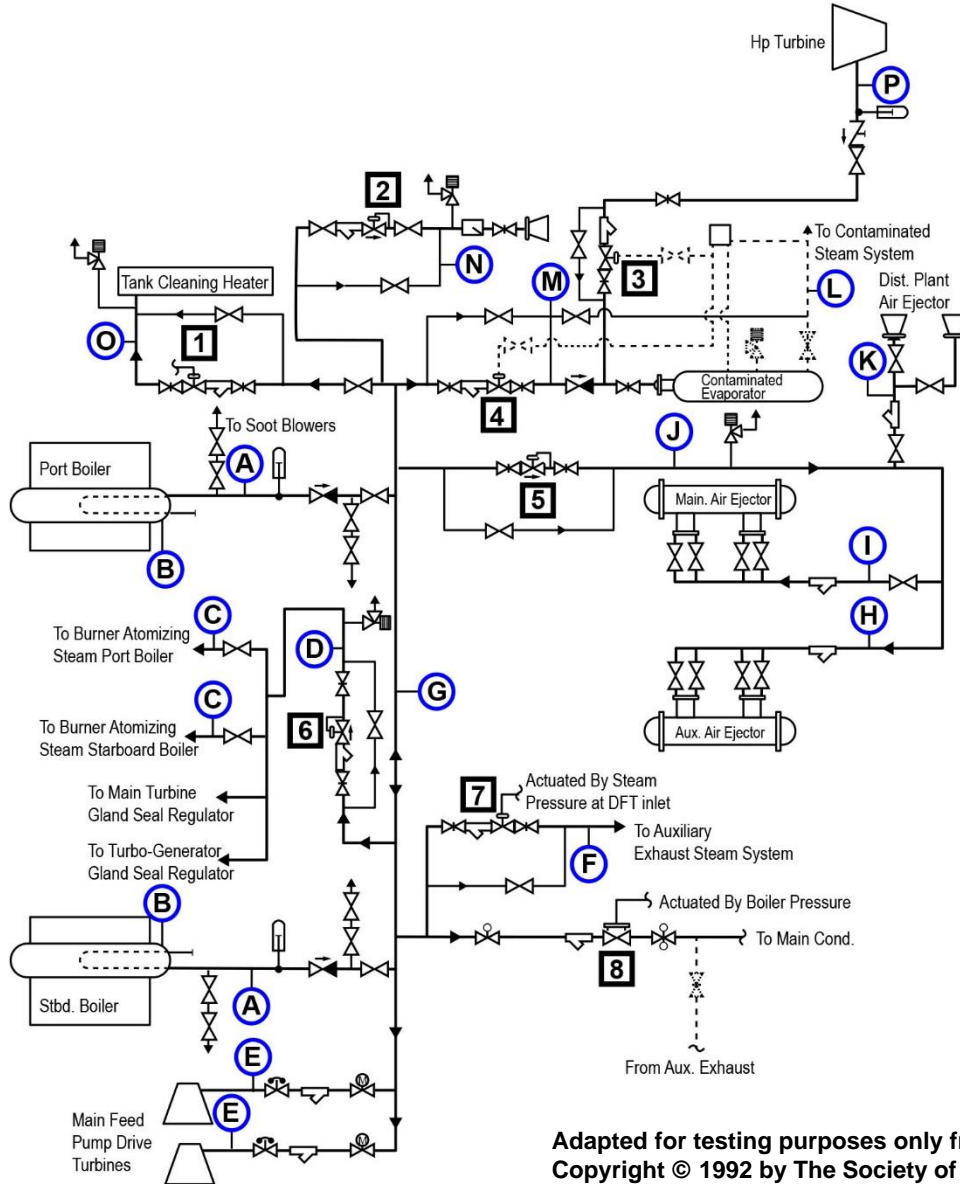

Nominal System Pressures	
Gauge	psig
A	850
B	860
C	143
D	143
E	850
F	32
G	850
H	143
I	143
J	143
K	143
L	130
M	350
N	140
O	130
P	205 (at full power)

Device Settings	
Valve	Psig
1	130
2	140
3	185
4	350
5	143
6	143
7	32
8	860

Adapted for testing purposes only from HARRINGTON, Marine Engineering
 Copyright © 1992 by The Society of Naval Architects and Marine Engineers
 Further reproduction prohibited without permission

SG-0008

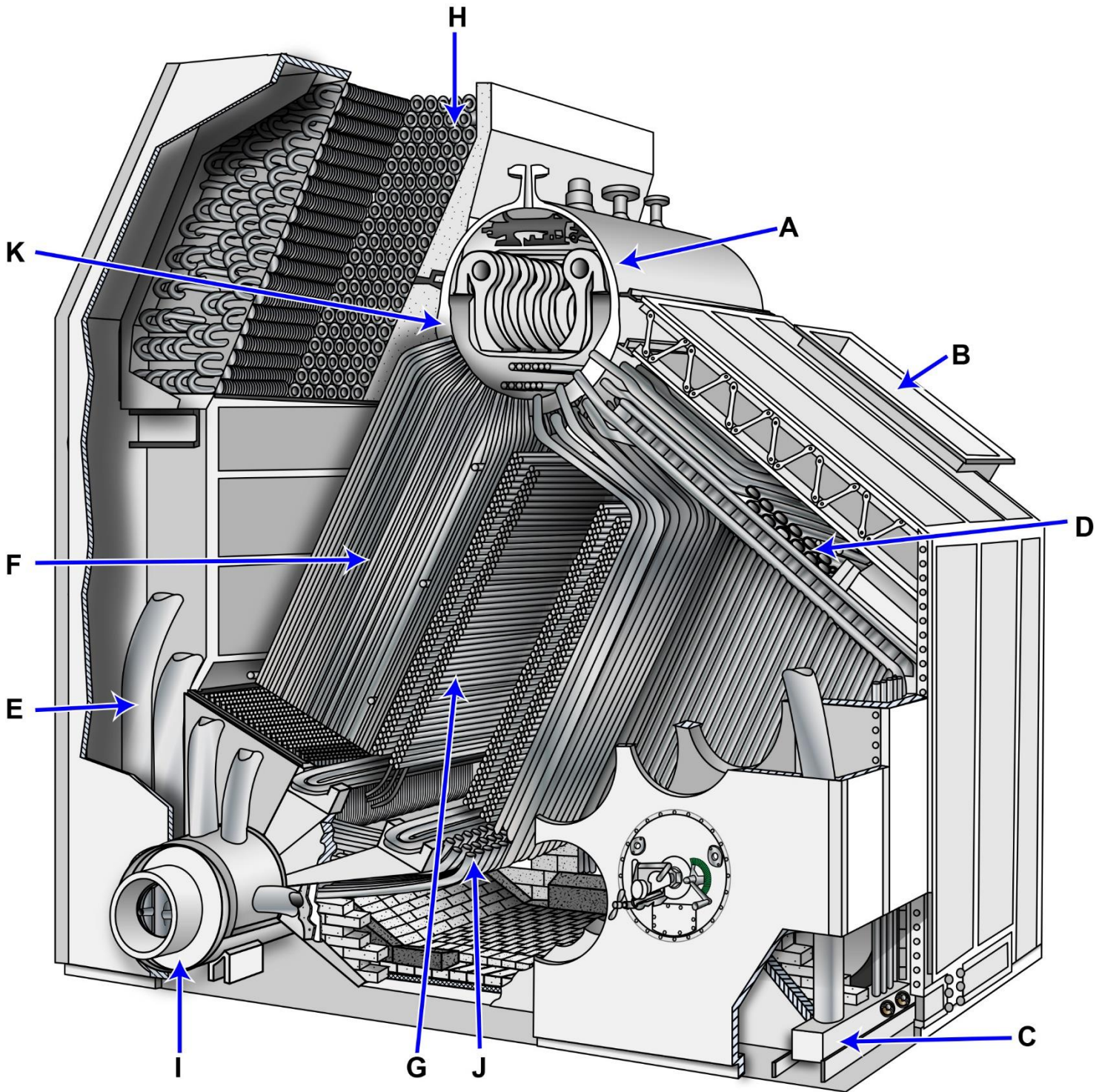

Adapted for testing purposes only from Principles of Naval Engineering
NAVPERS 10788-B
Further reproduction prohibited without permission