

## U.S.C.G. Merchant Marine Exam

OSV – Chief Engineer

Q682 General Subjects

(Sample Examination)

**Choose the best answer to the following Multiple-Choice Questions:**

1. In a closed-loop process control system, what is meant by the integral mode of control?
- A. It is a control mode that produces a control action that is proportional to the rate at which the error is changing.
  - B. It is a control mode that produces a control action that is proportional to the gain.
  - C. It is a control mode that produces a control action that is proportional to the error.
  - D. It is a control mode that produces a control action that is proportional to the accumulation of error over time.

Correct answer: D

2. In a closed-loop process control system, what term is used to describe the action of measuring the difference between the actual result and the desired result and using that difference to drive the actual result toward the desired result?
- A. Feedback
  - B. Gain
  - C. Deadband
  - D. Instability

Correct answer: A

3. A hydraulic fluid flow control circuit, controlling linear actuator speed, with the pump operating below maximum operating pressure is known as the \_\_\_\_\_.
- A. metered-out circuit
  - B. bleed-in circuit
  - C. bleed-off circuit
  - D. metered-in circuit

Correct answer: C

4. Assuming valve "A" is correctly aligned in the no-flow position as shown with the system in operation, which of the following statements is true? Illustration GS-0049
- A. Valve "C" would be closed.
  - B. Valve "B" would be open before valve "D".
  - C. The fixed delivery pump would be stopped automatically by a pressure switch.
  - D. Valve "D" would normally open before valve "B".

Correct answer: D

5. In order for the hydraulic pump installed in a constant flow system to maintain adequate flow, the pump suction should \_\_\_\_\_.
- A. be arranged to develop the theoretically maximum attainable vacuum
  - B. be provided with three to five 1/2 inch holes in the vertical, suction line to prevent pump starvation should the strainer become fouled
  - C. be taken directly off the reservoir bottom without regard to filters or strainers
  - D. be arranged to develop a maximum vacuum of approximately 10" of mercury

Correct answer: D

6. A horizontal electro-mechanical anchor windlass is equipped with two warping heads, two wildcats, two manual brake handwheels, two clutch control levers, and a multipoint lever-operated pedestal-mounted controller. What statement is true as it pertains to the operation of the pedestal-mounted controller?
- A. The pedestal-mounted controller allows both the warping heads and the wildcats to rotate in either direction of rotation at discrete speeds from zero to maximum.
  - B. The pedestal-mounted controller allows both the warping heads and the wildcats to rotate in only one direction of rotation at discrete speeds from zero to maximum.
  - C. The pedestal-mounted controller allows the warping heads to rotate in either direction of rotation, but the wildcats in only one direction of rotation at discrete speeds from zero to maximum.
  - D. The pedestal-mounted controller allows the wildcats to rotate in either direction of rotation, but the warping heads in only one direction of rotation at discrete speeds from zero to maximum.

Correct answer: A

7. What statement is true concerning the door interlock devices associated with a winding drum or traction drive passenger elevator onboard ship?
- A. Door interlocks are used to prevent elevator operation if the doors are still closed and only allow elevator operation if the doors are proved open.
  - B. Door interlocks are used to over-ride elevator emergency status in a shipboard emergency when elevators are required to be used.
  - C. Door interlocks are used to prevent elevator operation in a shipboard emergency when elevators are not to be used.
  - D. Door interlocks are used to prevent elevator operation if the doors are still open and only allow elevator operation if the doors are proved closed.

Correct answer: D

8. While a vessel is underway in periodically unmanned engine room condition, No.2 SSDG is to be down for repairs for at least the next 24 hours. Since the vessel is nearing US navigable waters, as chief engineer you wish the bridge be immediately informed of the availability of No.2 SSDG to support the electrical power requirements of maneuvering. How would you best ensure that the bridge be so informed?
- A. The request would be written as a note posted on the first assistant engineer's stateroom door.
  - B. The request would be written as a note posted on the No.2 SSDG panel of the main switchboard.
  - C. The request would be written as a special instruction in the Chief Engineer's night order book.
  - D. The request would be made of the duty engineer orally assuming that the word shall be passed on to his or her relief.

Correct answer: C

9. Before doing any work on a hydraulic system equipped with accumulators, you should \_\_\_\_\_.
- A. pump the hydraulic fluid into the accumulators to prevent fluid loss
  - B. drain the accumulators and purge with oxygen
  - C. bleed off all stored energy from the accumulators
  - D. completely charge the accumulators to prevent system energy loss

Correct answer: C

10. When changing to a fire-resistant hydraulic fluid in a system, it is important to check the compatibility of the new fluid with the system's \_\_\_\_\_.
- A. paint
  - B. metals and plating
  - C. seals
  - D. all of the above

Correct answer: D

11. When normal operating pressure is applied to the hydraulic oil in a high-pressure system, the oil \_\_\_\_\_.
- A. volume will increase
  - B. viscosity will increase
  - C. floc point will increase
  - D. viscosity will decrease

Correct answer: B

12. If dirt is allowed to contaminate the sump of a hydraulic deck crane, which of the following problems will occur?
- A. The internal parts of the pump and hydraulic motor will wear excessively.
  - B. The sheathing on the hydraulic lines will fracture.
  - C. All the seals in the hydraulic lines will immediately blow out.
  - D. The lifting capacity of the crane will be immediately reduced by 70%.

Correct answer: A

13. Hydraulic system reservoirs are often fitted with a combined filler/breather cap. If the breather element becomes fouled, the \_\_\_\_\_.
- A. reservoir will become pressurized
  - B. flow through the return lines will be stopped
  - C. actuator response time will be halved
  - D. reservoir will be subjected to a partial vacuum

Correct answer: D

14. A gradual decrease in the discharge pressure of an operating hydraulic pump can be caused by \_\_\_\_\_.
- A. the four-way control valve failing to shift
  - B. the bleeder valve sticking in the open position
  - C. a clogged air vent filter on the oil reservoir
  - D. cold hydraulic fluid

Correct answer: C

15. The function of item "7" shown in the illustration is to \_\_\_\_\_. Illustration GS-0153
- A. direct the flow of the oily-water mixture against the coalescer bed
  - B. support the tank access panel
  - C. prevent separated oil from mixing with the incoming bilge water
  - D. allow the oil accumulated to exit the device, while remaining separated from the liquid

Correct answer: C

16. Referring to the illustration, suppose after initiating the oil discharge mode, the oily-water separator fails to come out of the oil discharge mode in a timely fashion. Cracking open the upper sampling valve reveals the presence of oil exiting under positive pressure. What is most likely the cause? Illustration GS-0175
- A. The lower oil/water interface detection probe fails to initiate the oil discharge mode.
  - B. The oil discharge check valve fails to open, and as a result no oil actually discharges.
  - C. The upper oil/water interface detection probe fails to end the oil discharge mode.
  - D. The clean water supply solenoid fails to open, and as a result provides no discharge pressure.

Correct answer: B

17. Referring to the illustration, suppose while in the oil separation processing mode, the oil content detector display screen shows 17.9 ppm and the oily-water separator is discharging back to the bilge water holding tank for recirculation. What is most likely the cause? Illustration GS-0175
- A. The oily-water separator bilge suction strainer is excessively clogged.
  - B. The bilge water holding tank contents is excessively contaminated with oil.
  - C. The bilge water holding tank level is excessively high resulting in a high-level alarm.
  - D. The oily-water separator service pump is excessively worn.

Correct answer: B

18. Coast Guard regulations concerning marine sanitation devices may be found in \_\_\_\_\_.
- A. 33 CFR Section 159
  - B. 33 CFR Section 153
  - C. 33 CFR Section 155
  - D. 33 CFR Section 156

Correct answer: A

19. In the pump shown in the illustration, what is the distance from the bottom of the inlet to the bottom end of the motor shaft? Illustration GS-0011
- A. 45 1/4 inches
  - B. 45 5/16 inches
  - C. 53 5/8 inches
  - D. 57 5/8 inches

Correct answer: D

20. As shown in the illustration, if figure "21" indicates the "TOP VIEW" of an orthographic projection, and figure "11" indicates the "FRONT VIEW", which figure would best represent the correct "RIGHT SIDE VIEW"? Illustration GS-0165
- A. Figure "2"
  - B. Figure "8"
  - C. Figure "10"
  - D. Figure "15"

Correct answer: C

21. A command signal input to the steering gear has initiated rudder movement for 20° right rudder. The follow-up mechanism at the beginning of the rudder movement will \_\_\_\_\_. Illustration GS-0123
- A. be in motion with a null input
  - B. not be in motion, thus a null input
  - C. be in motion providing an input to place the variable stroke pump on maximum stroke
  - D. be in motion providing an input to place the variable stroke pump at null stroke

Correct answer: A

22. If oil under pressure is supplied to the area noted as "N" on the vane in the illustration \_\_\_\_\_. Illustration GS-0116
- A. "O" will rotate clockwise as oil is returned from the area between "M" and "I"
  - B. "O" will be hydraulically locked in place even though oil is returned to the main pump from the area between "M" and "I"
  - C. "O" will rotate counter-clockwise as oil is returned from the area between "M" and "I"
  - D. "Q" will rotate counter-clockwise as oil is returned from the area between "M" and "I"

Correct answer: C

23. The operation of the device shown in the illustration is dependent upon \_\_\_\_\_. Illustration GS-0116
- A. all items, similar to "I" move as the rudder stock rotates
  - B. all items, similar to "N" move as the rudder stock rotates
  - C. both "I" and "N" move as the rudder stock rotates
  - D. neither "I" nor "N" move as the rudder stock rotates

Correct answer: B

24. A water line ruptures under pressure and floods the engine room causing \$30,000(USD) damage to the machinery. By law, this must be reported to the \_\_\_\_\_.
- A. U.S. Coast Guard
  - B. engine manufacturer
  - C. owner or his agent
  - D. insurance underwriter

Correct answer: A

25. Oil sprays on to a hot piece of machinery, catches fire and causes \$35,000 damage to your vessel. By law this must be reported to the \_\_\_\_\_.
- A. U.S. Salvage Association Survey at the next U.S. port
  - B. principal surveyor of the American Bureau of Shipping at the next U.S. port
  - C. Officer in Charge, Marine Inspection at the first port of arrival
  - D. nearest Coast Guard unit

Correct answer: C

26. In accordance with 46 CFR Subchapter I (Cargo and Miscellaneous Vessels), it is the duty of the chief engineer to acquire and seal a sample of fuel oil received whenever fuel oil bunkers are taken. This sample must be preserved until \_\_\_\_\_.
- A. it can be sent ashore to the proper oil company personnel for testing and the results entered in the Oil Record Book, CG-480
  - B. the voyage is completed
  - C. return to the first U.S. port where upon it must be sent ashore for chemical analysis and the findings submitted to the nearest officer in charge, Marine Inspection
  - D. that particular supply of oil is exhausted

Correct answer: D

27. Control system diagrams use standard symbols to describe the component function required for the system to achieve its intended control functions. Standard symbols are used to allow engineers to describe the logic and component functions. Define the function of symbol "I" as shown in the illustration. Illustration GS-0180
- A. High Select Signal Processor
  - B. Low Select Signal Processor
  - C. Integral Processor
  - D. Difference Signal Processor

Correct answer: B

28. A 'Proportional Only' controlled automatic process loop is oscillating continually, above and below the setpoint. To stabilize this controller and loop using the 'gain' adjustment, what controller/loop response would you expect upon process changes vs. setpoint?
- A. By decreasing reset, the system's oscillations should subside vs. setpoint after an upset.
  - B. By decreasing gain, the process should return to a straight line response vs. setpoint after an upset.
  - C. By increasing gain, the system's oscillations should subside vs. setpoint after an upset.
  - D. By decreasing gain gradually, the process should stabilize in a 'quarter wave' response to system's upsets vs. the setpoint.

Correct answer: D

29. Alkylbenzene ISO 32 cSt synthetic refrigerant oil is miscible and suitable to use with which of the following refrigerants?
- A. R-22
  - B. R-32
  - C. R-134a
  - D. R-143a

Correct answer: A

30. What is the color coding for a storage container of R-134a refrigerant?
- A. light blue
  - B. purple
  - C. grey
  - D. green

Correct answer: A

31. When installing a mechanical shaft seal on a refrigeration compressor, extreme care must be taken to prevent what from happening?
- A. dirt and foreign particles from coming in contact with the highly polished sealing surfaces
  - B. any lubricant from contacting the stationary seal face that would cause etching of the face surface
  - C. the spring from being damaged by the corrosive effects of excessive handling
  - D. any lubricant from contacting the carbon surface that would cause the expulsion of the saturated Teflon film

Correct answer: A

32. A refrigeration unit will tend to short-cycle when operating under what conditions?
- A. under heavy loads
  - B. during hot gas defrost
  - C. lack of refrigerant
  - D. during starting conditions

Correct answer: C

33. A thermostatic expansion valve is properly controlling evaporator superheat. Adjusting this valve to lower the evaporator superheat setting will result in which of the following?
- A. the evaporator feed will increase
  - B. the expansion valve will further close
  - C. the expansion valve diaphragm will rupture
  - D. the evaporator pressure will decrease

Correct answer: A

34. Concerning the proper installation of the sensing bulb of a thermal expansion valve that is attached to the evaporator tail coil on a horizontal run, which statement is true?
- A. the bulb should be attached so that the pinched off tubing should be oriented up and the capillary tube running to the valve diaphragm should be oriented down
  - B. the bulb should be attached so that the pinched off tubing should be oriented down and the capillary tube running to the valve diaphragm should be oriented up
  - C. the bulb should be attached with no regard to the orientation of the pinched off tubing or the capillary tube running to the valve diaphragm
  - D. the bulb should be attached so that the pinched off tubing should be oriented to one side and the capillary tube running to the valve diaphragm should be oriented to the opposite side

Correct answer: B

35. If the superheat value of the thermostatic expansion valve is adjusted too high, what would be the result?
- A. the suction line of the compressor will be abnormally cold
  - B. the evaporator will be overfed with liquid refrigerant
  - C. the heat removal capacity of the evaporator will increase
  - D. the suction line of the compressor will be abnormally warm

Correct answer: D



36. Vapor bubbles present in the liquid upon arrival to the thermal expansion valve in a refrigeration system may cause erosion of the expansion valve's needle and seat. This, in turn, could cause what condition?
- A. TXV hunting
  - B. TXV freezing shut
  - C. TXV overheating
  - D. TXV freezing open

Correct answer: A

37. High suction pressure accompanied by low suction temperature to a refrigeration system compressor is caused by which of the following?
- A. the expansion valve is insufficiently opened
  - B. the king valve is insufficiently open
  - C. the expansion valve being open too wide
  - D. a clogged liquid-line strainer

Correct answer: C

38. Technicians servicing small refrigeration appliances can employ what type of recovery equipment?
- A. passive only
  - B. active only
  - C. either active or passive
  - D. do not need to recover the refrigerant

Correct answer: C

39. Using the device shown in the illustration, which of the following statements is true when adding refrigerant as a vapor to the low side of the refrigeration system? Illustration RA-0001
- A. The hose labeled "H" should be connected to the suction service valve service port, the hose labeled "J" should be connected to the vapor valve on the refrigerant cylinder and the valve labeled "G" should be closed.
  - B. The hose labeled "K" should be connected to the suction service valve service port, the hose labeled "J" should be connected to the vapor valve on the refrigerant cylinder and the valve labeled "C" should be closed.
  - C. The hose labeled "H" should be connected to the suction service valve service port, the hose labeled "J" should be connected to the vapor valve on the refrigerant cylinder and the valve labeled "G" should be open.
  - D. The hose labeled "K" should be connected to the suction service valve service port, the hose labeled "J" should be connected to the vapor valve on the refrigerant cylinder and the valve labeled "C" should be open.

Correct answer: C

40. For safe storage, the maximum allowable temperature to which refrigerant bottles should be exposed is what temperature?
- A. 100°F
  - B. 125°F
  - C. 150°F
  - D. 175°F

Correct answer: B

41. A room humidistat initiates the lowering of the humidity of the conditioned supply air to a space, while the actual process is accomplished by what means?
- A. lowering both the cooling coil temperature and the reheater temperature
  - B. raising the cooling coil temperature and lowering the reheater temperature
  - C. raising both the cooling coil temperature and the reheater temperature
  - D. lowering the cooling coil temperature and raising the reheater temperature

Correct answer: D

42. In general, the thermal bulb for a thermal expansion valve used in a reciprocating air conditioning system is usually charged with what substance?
- A. distilled water
  - B. mercuric sulfate
  - C. the same refrigerant as the system
  - D. bees wax

Correct answer: C

43. When pumping down an air conditioning system to test the low-pressure cutout switch, assuming that the compressor is running, what should be done to initiate the test?
- A. stop the compressor
  - B. close the "king" valve
  - C. secure the condenser
  - D. stop the circulating pump

Correct answer: B

44. What form of communication provides the greatest information richness, which is the amount of verbal and non-verbal information that a communication channel carries?
- A. Small-group meeting
  - B. Telephone conversation
  - C. One-on-one, face-to-face
  - D. Large-group meeting

Correct answer: C

45. Leadership style sometimes must change with the readiness level of the employees. Which of the following employee readiness level scenarios would be best suited for adopting a delegating leadership style?
- A. Where the employees are unable and unwilling or insecure
  - B. Where the employees are unable but willing or confident
  - C. Where the employees are able and willing or confident
  - D. Where the employees are able but unwilling or insecure

Correct answer: C

46. During the "storming" phase of group development, conflicts generally arise over goals, task behaviors, and leadership roles. If these conflicts are not successfully resolved, what may result?
- A. The group may not successfully develop teamwork, group cohesion, mutual trust and cooperation, and this probably will interfere with successful accomplishment of the group's mission.
  - B. The group may not successfully develop teamwork, group cohesion, mutual trust and cooperation, but this should not interfere with successful accomplishment of the group's mission.
  - C. The group will nevertheless successfully develop teamwork, group cohesion, mutual trust and cooperation, resulting in successful accomplishment of the group's mission.
  - D. The group will nevertheless successfully develop teamwork, group cohesion, mutual trust and cooperation, but this probably will interfere with successful accomplishment of the group's mission.

Correct answer: A

47. Of all the individual components of a pre-fire planning package, which component contains information about emergency duty station locations and responsibilities for each crew member by position AND name?
- A. Fire control plan
  - B. Pre-fire plan
  - C. Station bill
  - D. Muster list

Correct answer: D

48. You are at a shipyard in dry-dock. New anodes for the impressed current system are being installed. The yard workers are installing the capastic layer on the hull. What is the primary function of the capastic epoxy?
- A. It raises the anode off the hull so as to improve the range of the anode current.
  - B. It protects the anode from impact with foreign objects.
  - C. It protects the hull coating from excessive current.
  - D. It prevents shorting of the anode current to the hull and aids in a wider current distribution to the hull.

Correct answer: D

49. One is slated to be a senior officer of a new vessel and is to participate in the 'Builder's Sea Trials'. What would you consider your responsibilities when asked to witness scheduled tests?
- A. Observe, note any deficiencies you may feel exist and convey them to your vessel owner's representatives.
  - B. Observe, report any possible deficiencies to the representatives of the regulatory bodies present.
  - C. Observe, report any possible deficiencies to shipyard representatives and regulatory body representatives.
  - D. Observe and convey your comments of any possible deficiencies to the shipyard representative conducting the test.

Correct answer: A

50. A vessel you are sailing on as chief engineer had its last dry-docking survey 2 years prior and is not enrolled in an underwater survey program in lieu of dry-docking. When is the next dry-docking due?
- A. 1 year
  - B. 6 months
  - C. 2 years
  - D. 3 years

Correct answer: A

51. If a vessel is to be laid up for an extended period of time with minimal utilities provided where freezing is not a concern, boilers may be laid up wet. What statement concerning wet boiler lay-up is true?
- A. The boiler should be filled with deaerated and chemically treated water until the water level is brought to the top of the sight glass.
  - B. The boiler should be filled with ordinary water (such as potable water) until the water level is brought to the top of the sight glass.
  - C. The boiler should be completely filled with ordinary fresh water (such as potable water) until water issues from the atmospheric vent.
  - D. The boiler should be completely filled with deaerated and chemically treated water until water issues from the atmospheric vent.

Correct answer: D

52. In a compression type automatic grease cup, the lubricant is forced into the bearing by \_\_\_\_\_.
- A. a Zerk fitting
  - B. a pressure gun
  - C. gravity flow
  - D. spring force

Correct answer: D

53. As the speed of an oil lubricated ball bearing increases, fluid friction, due to churning, generates heat. This condition may be avoided by \_\_\_\_\_.
- A. adding more lubricant until the ball bearings are completely covered with a layer of oil
  - B. reducing the quantity of lubricant until only a mist of oil is present on the ball bearings
  - C. installing oil rings on the ball bearings
  - D. maintaining a continuous fluid film of oil on the bearings

Correct answer: B

54. What statement is true concerning a well-planned turnover procedure from one crew to another?
- A. The relieving crew embarks as the relieved crew disembarks.
  - B. The sequence of relieving crew embarking, and relieved crew disembarking is not critical.
  - C. The relieving crew embarks after the relieved crew disembarks.
  - D. The relieving crew embarks prior to the relieved crew disembarking.

Correct answer: D

55. As a first assistant or chief engineer, what is the source of your authority?

- A. Your authority is earned by you as a function of daily performance.
- B. Your authority is conferred upon you by the ship's master upon reporting aboard.
- C. Your authority is conferred upon you by the license you hold and maritime tradition.
- D. Your authority is bestowed upon you by its acceptance by your subordinates.

Correct answer: C

56. Which of the following would be a positive outcome associated with performing a trend analysis of data acquired from lube oil testing, vibration sensors, performance data sensors, and thermographic sensors?

- I) Avoidance of catastrophic failures.
- II) Determining the need of when to perform corrective maintenance.
- III) Improving the overall effectiveness of the engineering plant.

- A. I only
- B. II only
- C. I and II only
- D. I, II, and III

Correct answer: D

57. As a management level engineering officer, you are apt to be the primary investigator investigating the root cause of the failure of a piece of machinery. Besides collecting and preserving the physical evidence of the failure and interviewing key personnel, which of the following supplemental information should be considered?

- I) Onboard operating and maintenance procedures
- II) Historical operating and maintenance records
- III) Technical manuals and specifications
- IV) Personnel training records

- A. I, II, and III only
- B. I, III, and IV only
- C. II, III, and IV only
- D. I, II, III, and IV

Correct answer: D

58. For planning purposes graphical charts can be a useful tool. What type of chart is good for a visual progress report and identifies work stages or activities on the vertical axis and the scheduled completion dates on the horizontal axis?

- A. Scatter plot
- B. Gantt chart
- C. Pie chart
- D. PERT chart

Correct answer: B

59. What federal agency enforces the prohibition of employment discrimination based on race, color, religion, sex, or national origin as it applies to shipboard employment onboard US flag vessels?
- A. Maritime Administration (MARAD)
  - B. Equal Employment Opportunity Commission (EEOC)
  - C. International Transport Workers' Federation (ITWF)
  - D. U.S. Coast Guard (USCG)

Correct answer: B

60. One of the means of alternative dispute resolution regarding a collective bargaining agreement dispute is arbitration. What is meant by arbitration?
- A. Negotiated settlement between company and union representatives facilitated by a mediator
  - B. Agreement to abide by a binding decision rendered by a company and union agreed-upon impartial person
  - C. Direct, in-house negotiated settlement between company and union representatives
  - D. Settlement reached as the result of litigation as part of a judicial proceeding in court

Correct answer: B

61. In accordance with 33 CFR Subchapter O (Pollution), which of the following statements is true concerning the signature of the Oil Record Book?
- A. The officer in charge of the engineering watch signs each entry occurring on the watch, and the chief engineer signs each page.
  - B. The officer in charge of the navigational watch signs each entry occurring on the watch, and the master signs each page.
  - C. The person in charge of an operation signs for that entry, and the master signs each page.
  - D. The person in charge of an operation signs for that entry, and the chief engineer signs each page.

Correct answer: C

62. Machinery spaces must be designed to minimize the exposure of personnel to noise in accordance with U.S. regulations. Manned machinery space noise must not exceed which noise level?
- A. 75 dB(A)
  - B. 85 dB(A)
  - C. 90 dB(A)
  - D. 110 dB(A)

Correct answer: C

63. One of your ship's indirect-drive steering gear drive motors needs to be replaced. In accordance with 46 CFR Subchapter J (Electrical Engineering), what minimum short-time rating should the replacement motor have in hours?
- A. 1/4 hour
  - B. 1/2 hour
  - C. 1 hour
  - D. Continuous operation at 15 percent load followed by 1 hour at full load.

Correct answer: D

64. In accordance with 33 CFR Subchapter O (Pollution), what is the definition of a "Type I Marine Sanitation Device"?
- A. A device that produces a fecal coliform bacteria count not greater than 200 per 100 milliliters and suspended solids not greater than 150 milligrams per liter.
  - B. A device that produces a fecal coliform bacteria count not greater than 200 per 100 milliliters and no visible floating solids.
  - C. A device that produces a fecal coliform bacteria count not greater than 1,000 per 100 milliliters and no visible floating solids.
  - D. A device that is designed to prevent the overboard discharge of treated or untreated sewage or any waste derived from sewage.

Correct answer: C

65. Prior to entering the navigable waters of the United States after an international voyage, your vessel must conduct drills according to 33 CFR regulations for ports and waterways safety that test steering system functionality and log that in the vessel logbook, unless the drill is conducted and logged on a regular basis at least once every three months. Within how many hours of arrival must these drills be performed?
- A. 6 hours
  - B. 12 hours
  - C. 24 hours
  - D. 48 hours

Correct answer: D

66. Resonant vibrations, which can cause machinery failure, occur when which of the following conditions happen?
- A. The natural frequency of the machinery is the same as the free vibration frequency.
  - B. The frequency of an external vibration is the same as one of the natural frequencies of the machinery.
  - C. The machinery is operated at the natural frequency with no external forces in play.
  - D. A forced frequency is placed on a piece of operating machinery.

Correct answer: B

67. Elevated metal levels present in a recent sample of used diesel engine crankcase lubricating oil is indicative of a condition. What would high silicon levels indicate?
- A. The lubricating oil has become contaminated with sand, dust, and dirt.
  - B. The lubricating oil's detergent additives have become depleted.
  - C. The lubricating oil has become excessively diluted with fuel oil.
  - D. The lubricating oil has become contaminated with engine coolant.

Correct answer: A

68. Compatibility of fuel is easily checked onboard ship to ensure that serious problems do not result. What statement concerning fuel incompatibility is true?

- A. Incompatible fuels, if allowed to mix, have a tendency to separate out from one another, and therefore must be vigorously blended.
- B. Incompatible fuels, if allowed to mix, have a tendency to form sludge, and therefore must not be blended.
- C. Incompatible fuels, if allowed to mix, have a tendency to separate out from one another, and therefore must not be blended.
- D. Incompatible fuels, if allowed to mix, have a tendency to form sludge, and therefore must be vigorously blended.

Correct answer: B

69. What type of maintenance system would be associated with a vibration monitoring analysis system?

- A. Planned maintenance system
- B. Predictive maintenance system
- C. Scheduled maintenance system
- D. Corrective maintenance system

Correct answer: B

70. Which of the following types of maintenance would be considered a reactive approach to maintenance as opposed to proactive?

- A. Predictive maintenance
- B. Planned maintenance
- C. Condition-based maintenance
- D. Corrective maintenance

Correct answer: D



## GS-0011

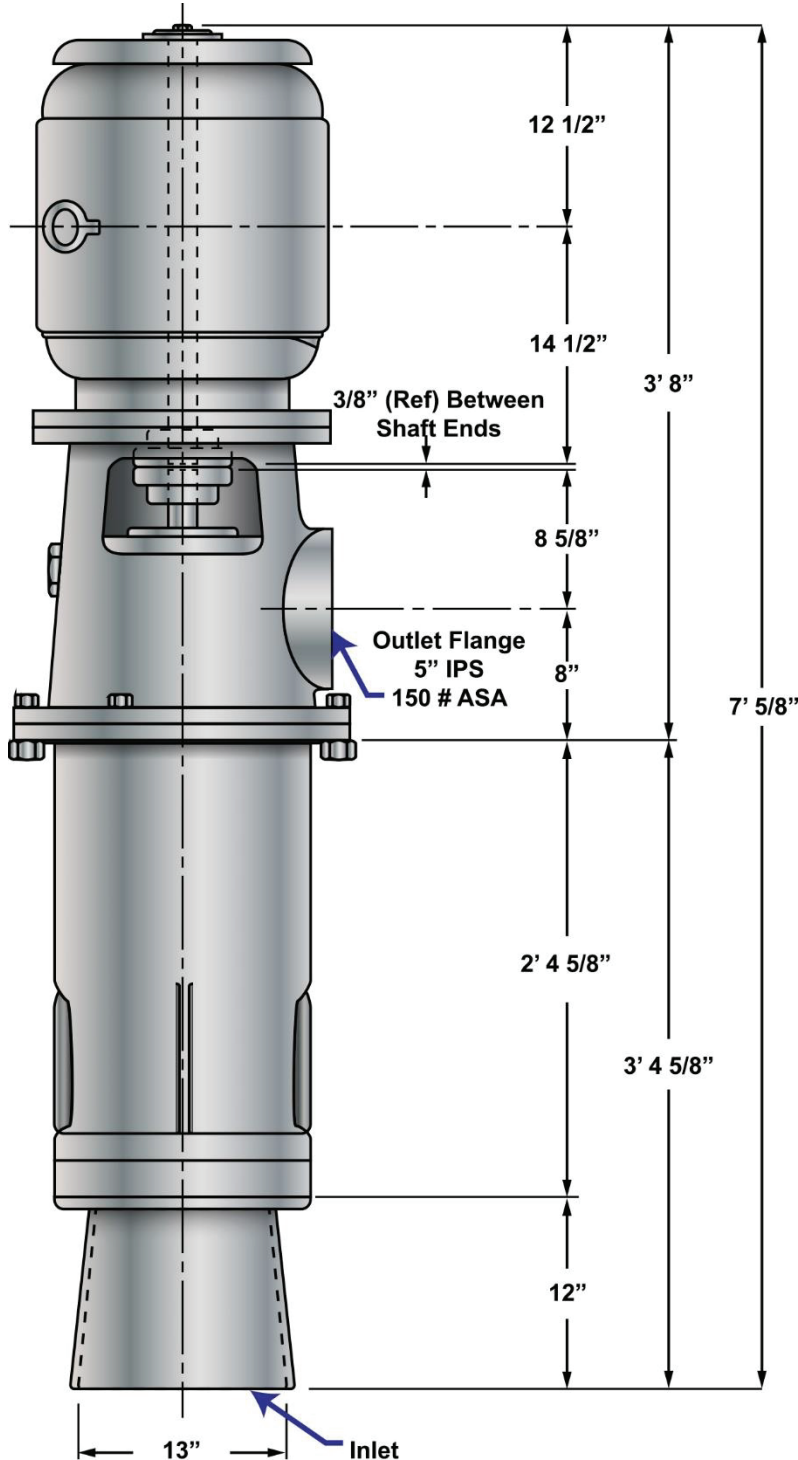

### MOTOR CHARACTERISTICS

Motor (A. C.)	Electro Dynamic
Rating H. P.	25
Speed R. P. M. (SYN.)	1200
Frame	365 VY
Type	TN
Volts	440
Cycles	60
Phase	3

### PUMP CHARACTERISTICS

Capacity G. P. M.	400
Speed R. P. M.	1150
Suction Lift "HG	10
B, H, P. @ 1200 SSU-75° F	24.9
Oil viscosity Range, SSU	74-7000
Viscosity Normal SSU @ 140° F	155
Discharge Normal PSIG	55
Fluid Handled, Lube Oil	2190 TEP.
Navy Specification	MIL-L-17331
Oil Temperature Range ° F	40-180

Illustration scale: 1" = 1'

Adapted for testing purposes only  
Further reproduction prohibited without permission



## GS-0116

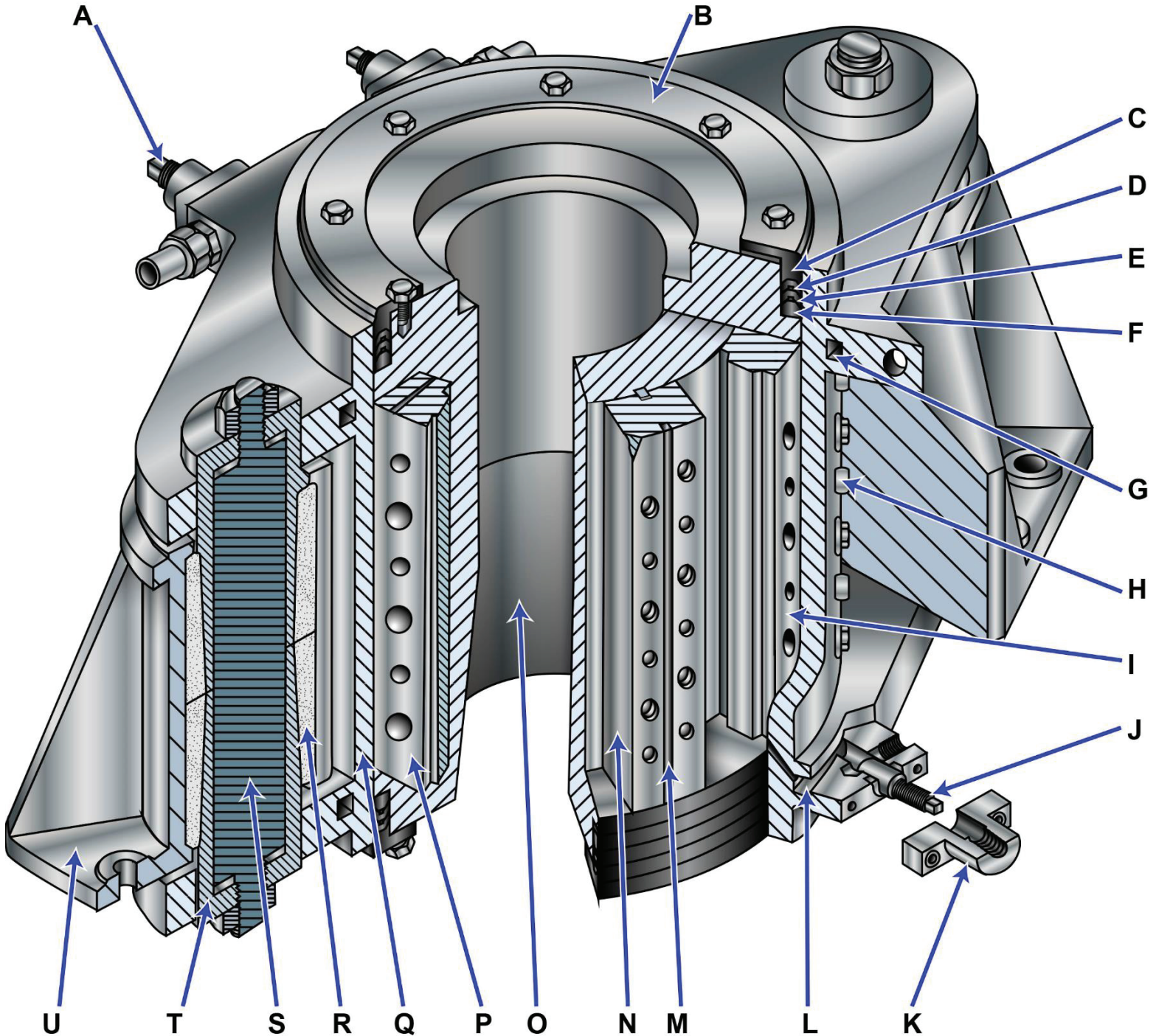

Adapted for testing purposes only from HUNT, Modern Marine Engineer's Manual, Vol. II  
Copyright © 2002 by Cornell Maritime Press, Inc.  
Further reproduction prohibited without permission

## GS-0123

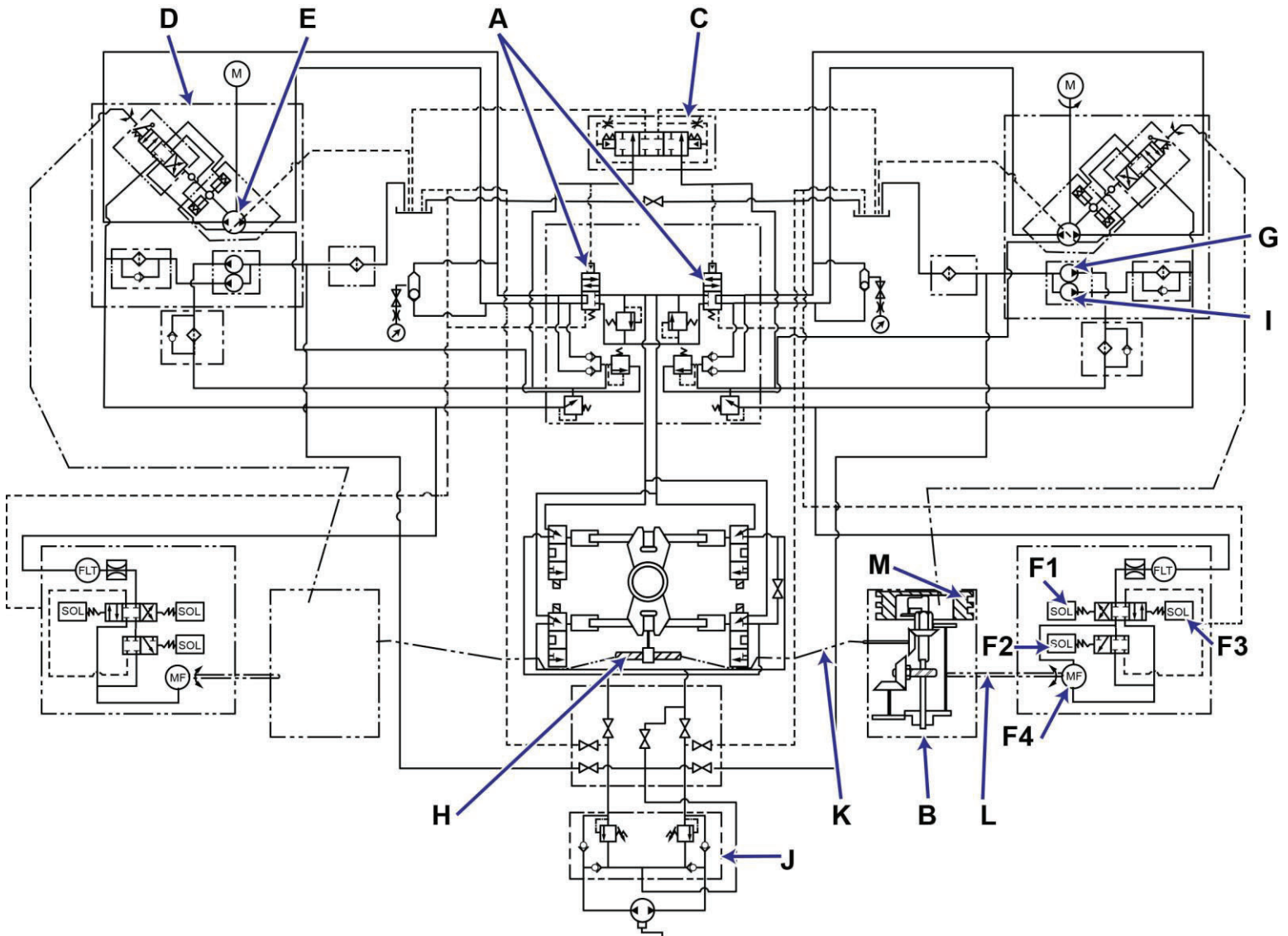

Adapted for testing purposes only from STUTMAN, Applied Marine Hydraulics  
Copyright © 1988 by Cornell Maritime Press, Inc.  
Further reproduction prohibited without permission

## GS-0153

### Control Room

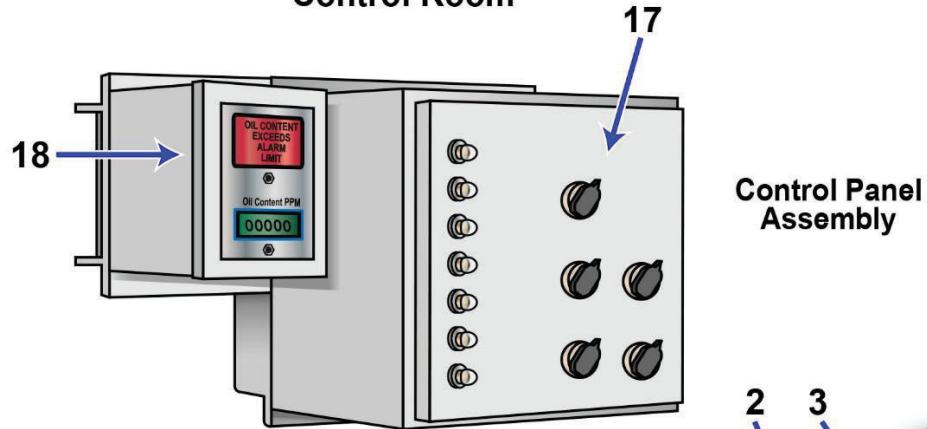

### Engine Room

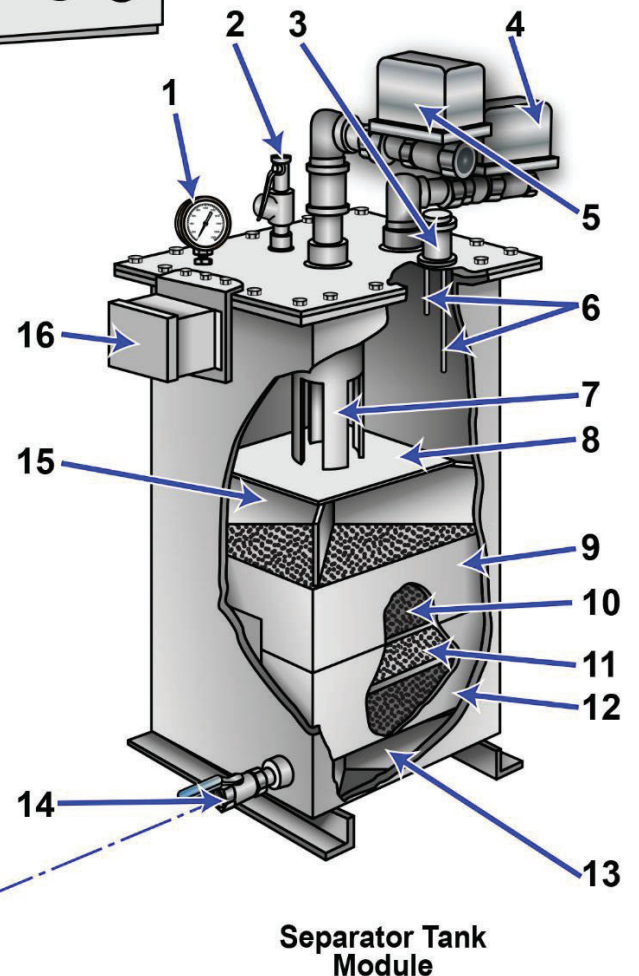
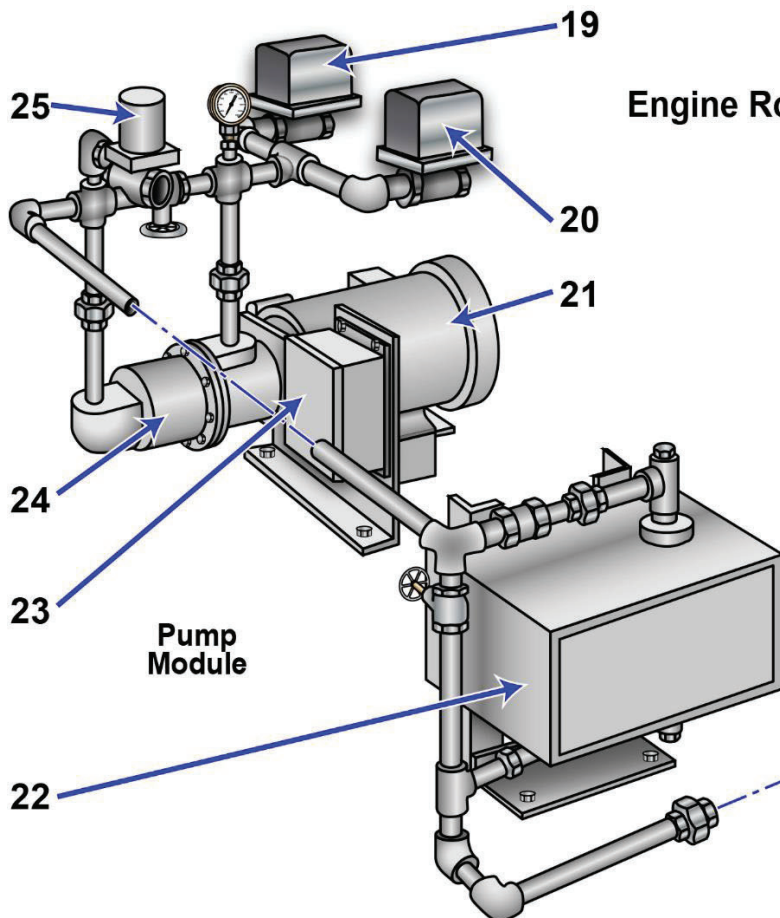

Adapted for testing purposes only from Operator, Unit and Direct Support Maintenance Manual Including Repair Parts and Special Tools List for Oil Water Separator  
TM 55-1925-285-13 & P

Further reproduction prohibited without permission

## GS-0165

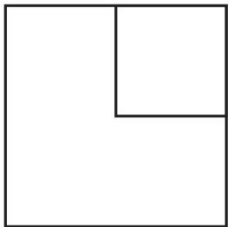

1.

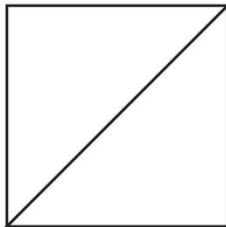

2.

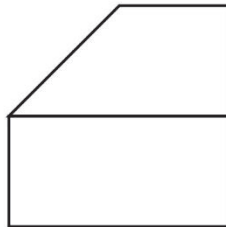

3.

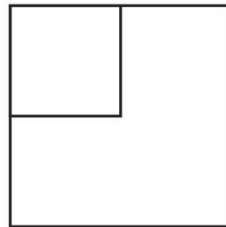

4.

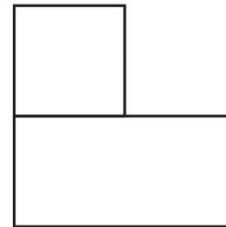

5.

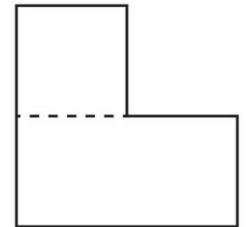

6.

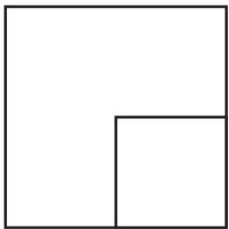

7.

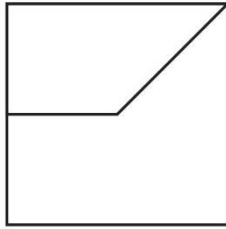

8.

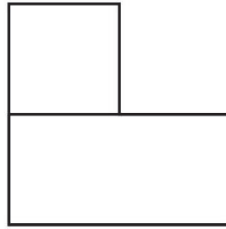

9.

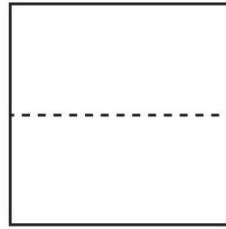

10.

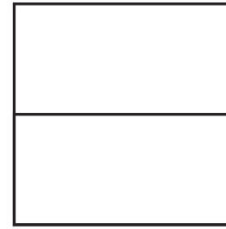

11.

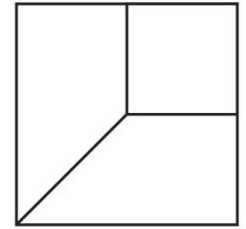

12.

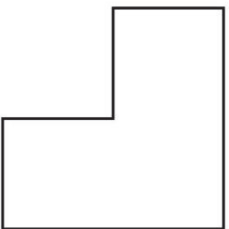

13.

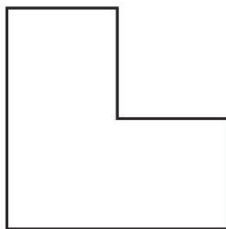

14.

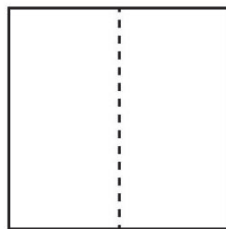

15.

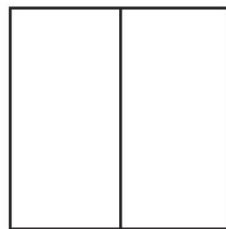

16.

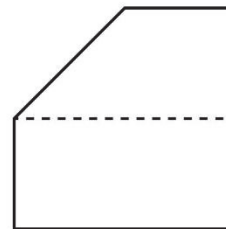

17.

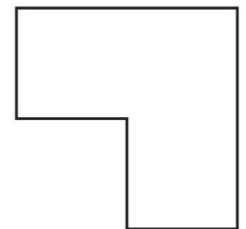

18.

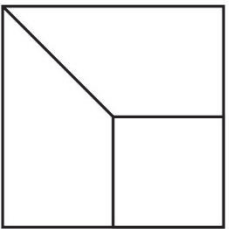

19.

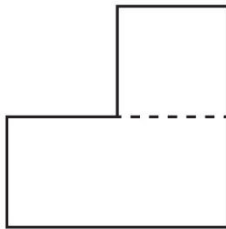

20.

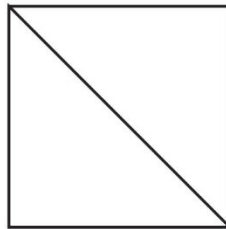

21.

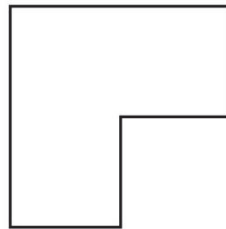

22.

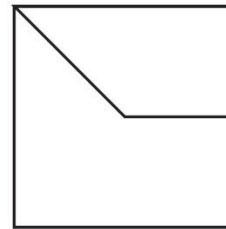

23.

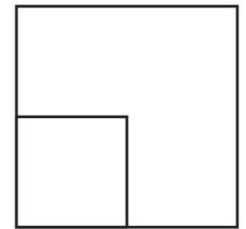

24.

Adapted for testing purposes only  
Further reproduction prohibited without permission

## GS-0175

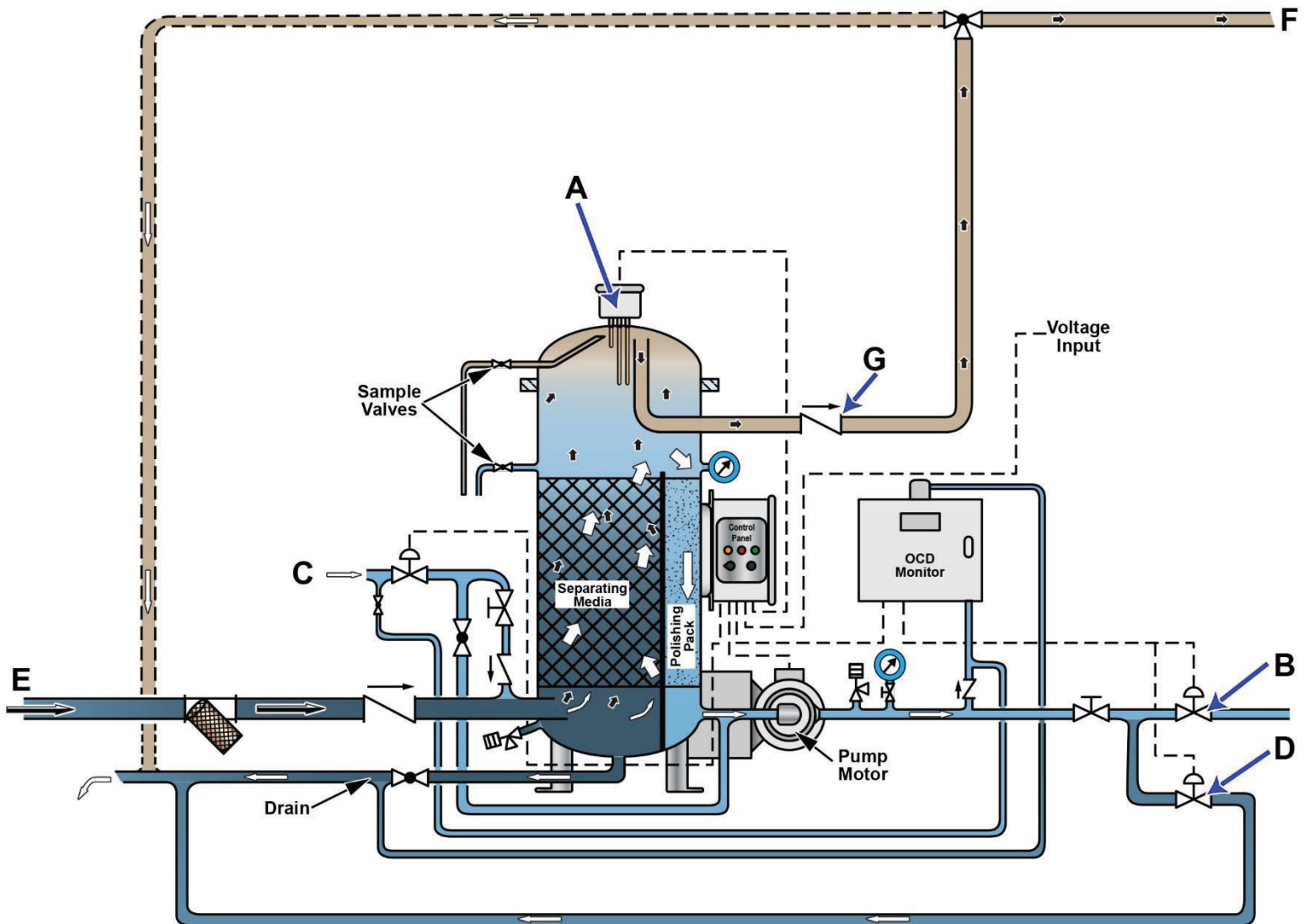

Adapted for testing purposes only from Heli-Sep Model 550/OCD Technical Manual  
Copyright © by Coffin World Water Systems  
Further reproduction prohibited without permission

## GS-0180



Adapted for testing purposes only from HUNT, Modern Marine Engineer's Manual, Vol. I  
Copyright © 1999 by Cornell Maritime Press  
Further reproduction prohibited without permission



## RA-0001

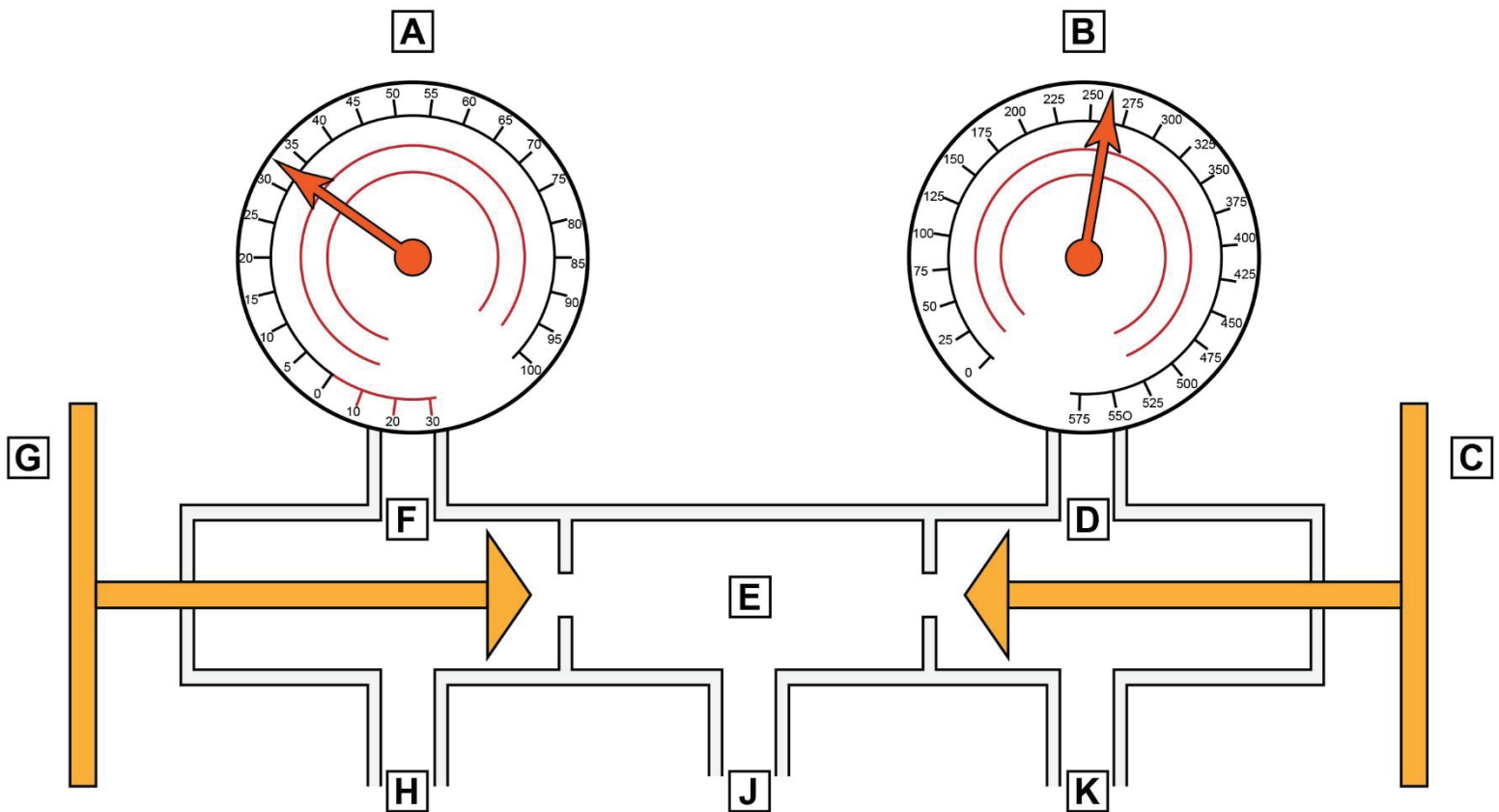

Adapted for testing purposes only from ALTHOUSE, Modern Refrigeration and Air Conditioning  
Copyright © 1992 by The Goodheart-Willcox Company, Inc.  
Further reproduction prohibited without permission