

U.S.C.G. Merchant Marine Exam

DDE – 1000/4000 HP

Q631 Steam Plants

(Sample Examination)

Choose the best answer to the following Multiple-Choice Questions.

1. Which of the following statements is correct concerning heat transfer?
- A. Heat is given off from a high temperature region known as a heat sink.
 - B. Heat transfer rate is affected most by the size of the heat sink involved.
 - C. Heat transfer rate is affected most by the temperature difference between the heat source and the heat sink.
 - D. Heat transfer by radiation will occur only by mass motion of a fluid substance.

Correct answer: C

2. Steam tables can be used to obtain the _____.
- A. specific fuel consumption under steady steaming conditions
 - B. steam generating capacity of a vessel's boilers
 - C. mechanical efficiency of the main unit
 - D. values for properties of water and steam vapor at various conditions

Correct answer: D

3. By which of the listed methods may heat be transferred from one body to another?
- A. Radiation
 - B. Convection
 - C. Conduction
 - D. All of the above.

Correct answer: D

4. The flash point of a residual fuel oil should be used to determine the highest temperature to which the oil may be heated _____.
- A. for centrifuging
 - B. in a storage tank
 - C. for atomizing
 - D. in the recirculating line

Correct answer: B

5. The property of a fuel oil which is a measurement of its available energy, is known as its _____.
- A. cetane index
 - B. cetane number
 - C. heating value
 - D. viscosity index

Correct answer: C

6. In terms of the completeness of combustion, in viewing the flame through the peephole, what would be the indication of the MOST complete combustion?
- A. Reddish flame
 - B. Yellow flame
 - C. Orange flame
 - D. Golden yellow flame

Correct answer: D

7. Control of the fuel oil metering valve in an automatically fired boiler is accomplished by a _____.
- A. pressure magnifying device in the steam coil outlet
 - B. steam pressure sensing device with linkage to the damper air vanes
 - C. metering device in the air supply line
 - D. signal from the feedwater electrode

Correct answer: B

8. The solenoid valves in the fuel oil supply line to a boiler are automatically closed by _____.
- A. a decrease in feed temperature
 - B. high furnace air pressure
 - C. high steam pressure
 - D. low steam pressure

Correct answer: C

9. When operating with the auxiliary feed line, feed water flow is controlled _____.
- A. automatically by the eco by-pass
 - B. manually by throttling the auxiliary feed stop-check valve
 - C. automatically by the main feedwater regulator
 - D. manually by adjustment of the auxiliary feedwater regulator spring setting

Correct answer: B

10. Under normal conditions, the rate of heat transfer in a feed water heater is most greatly affected by the _____.
- A. pH of the feed water
 - B. density of the feed water
 - C. speed of the feed pump
 - D. temperature differential between the steam and feed water

Correct answer: D

11. Design characteristics of a velocity-compounded impulse turbine include the utilization of _____.
- A. one or more nozzles with one row of rotating blades
 - B. a low velocity steam jet from a nozzle
 - C. a single pressure stage with two or more velocity stages
 - D. two or more simple impulse stages

Correct answer: C

12. Nozzle diaphragms are installed in pressure-compounded impulse turbines to _____.

- A. support shrouding
- B. support moving blades
- C. eliminate blade and nozzle losses
- D. hold the nozzles of the stage and admit steam to moving blades

Correct answer: D

13. A turbine assembly in which steam flows in series through a high-pressure turbine and then on to a low-pressure turbine, with both turbines driving a common reduction gear through separate shafts, is classified as _____.

- A. dual series
- B. tandem compound
- C. tandem, double flow
- D. cross compound

Correct answer: D

14. Why would superheated steam be used in a propulsion turbine instead of saturated steam?

- A. Greater heat energy available per pound of steam
- B. Less specific energy available per pound of steam
- C. Higher pressure available than saturated steam
- D. Lower required specific volume than saturated steam

Correct answer: A

15. As steam accomplishes work in an engine or turbine, the pressure of the steam is reduced because it _____.

- A. expands in volume
- B. becomes saturated again
- C. becomes superheated again
- D. diminishes in volume

Correct answer: A

16. The correct radial clearances between the rotor and the casing in a propulsion turbine are maintained by the turbine _____.

- A. journal bearings
- B. thrust bearing
- C. interstage packing
- D. diaphragms

Correct answer: A

17. Turbine casing flanges are sometimes provided with a system of joint grooving to _____.

- A. inject sealing compound between the casing halves
- B. increase contact pressure between the casing halves' flanges
- C. form a labyrinth seal between the casing halves
- D. ensure perfect alignment of casing halves

Correct answer: A

18. When the temperature of the main turbine lubricating oil is lowered, an increase will occur in the _____.

- A. concentration of contaminants
- B. flash point
- C. pour point
- D. viscosity

Correct answer: D

19. Which of the filters listed will deplete the additives in lubricating oil?

- A. Extended area membrane filter
- B. Cloth bag extractor
- C. Absorbent filter
- D. Adsorbent filter

Correct answer: D

20. Of the many impurities commonly found in marine lubricating oil, which of the following CANNOT be removed by a centrifugal purifier at normal operating speeds and temperatures?

- A. Carbon particles
- B. Water
- C. Diesel fuel oil
- D. Metal particles

Correct answer: C

21. When monitoring a steam propulsion plant lubricating oil pressures, what pressure is the most critical to check regularly while underway?

- A. The pressure immediately upstream of the variable orifice.
- B. The pressure at the most remote bearing.
- C. Lube oil service pump discharge pressure.
- D. The pressure immediately downstream of the variable orifice.

Correct answer: B

22. The splits located in the halves of main reduction gear bearings are aligned at an angle to the horizontal in order to resist _____.

- A. wiping
- B. axial stress
- C. oil loss
- D. steam loss

Correct answer: A

23. Which of the coupling types listed is shown in the illustration? Illustration SE-0001

- A. Solid
- B. Pin
- C. Gear
- D. Claw

Correct answer: C

24. A Kingsbury, or pivot shoe type thrust bearing, can bear much greater loads per square inch of working surface than can parallel surface bearings because provisions are made in the Kingsbury bearing _____.

- A. for adjusting the filler piece thickness behind the pivotal-shoes to give a more accurate fit
- B. to allow the leveling plates to pivot on the collar when thrust loads are applied
- C. for the shoes to tilt slightly, thereby allowing the formation of a wedge-shaped oil film under a thrust load
- D. for automatically adjusting clearances to the correct value when wear occurs

Correct answer: C

25. While your vessel is underway at normal speed, a steam drum safety valve develops a significant leak. Your first corrective action should be to _____.

- A. inspect the escape piping for binding on the valve body
- B. secure the boiler and blank off the valve flange
- C. attempt to reseat the valve using the hand releasing gear
- D. secure the boiler and check the valve spring compression

Correct answer: C

26. Where do fuel oil vapors tend to accumulate in an engine room?

- A. At the point in the engine room where the vapors were initially formed
- B. Oil vapors tend to distribute throughout the engine room evenly
- C. In the lower engine room spaces, especially in the bilges
- D. In the upper engine room spaces, especially in the fidley

Correct answer: C

27. With reference to the chart, if a boiler generates saturated steam at 385.3 psig, how much heat per pound was required to change the water into steam if the feed water temperature was initially 220°F? Illustration SG-0004

- A. 96.85 BTU
- B. 97.15 BTU
- C. 1016.40 BTU
- D. 1196.45 BTU

Correct answer: C

28. The bottom blow valve on a water-tube boiler is usually attached to the _____.

- A. external downcomers
- B. steam and water drum
- C. boiler mud drum
- D. floor tubes

Correct answer: C

29. Which type of energy conversion is associated with an operating steam boiler?

- A. Kinetic
- B. Mechanical
- C. Thermal
- D. Specific

Correct answer: C

30. The purpose of the boiler drum air cock is to _____.

- A. admit air when the boiler is being emptied
- B. permit escape of air when steam is forming in the drum after lighting off
- C. permit escape of air when the boiler is being filled
- D. all of the above

Correct answer: D

31. The purpose of the separating nozzle in the accumulator of a water-tube, coil-type, steam generator is to separate _____.

- A. dry steam from the steam and water mixture
- B. condensate from feedwater
- C. superheated steam from saturated steam
- D. sludge accumulations from feedwater

Correct answer: A

32. In a coil-type forced circulation water-tube boiler, _____.

- A. steam demand response is comparatively rapid
- B. steam is recirculated through heating coils in the boiler
- C. unevaporated feedwater is discharged through the skim tube
- D. steam demand response is slow

Correct answer: A

33. Which of the following statements concerning fire-tube boilers is correct?

- A. Combustion gases flow through the tubes.
- B. Flames impinge on the tubes.
- C. Combustion occurs in the tubes.
- D. Water flows through the tubes.

Correct answer: A

34. A boiler pressuretrol senses steam pressure changes and _____.

- A. controls the flow of feedwater to the boiler
- B. monitors the boiler high water level
- C. secures the fires when a fusible plug burns out
- D. automatically regulates the quantity of oil and air flow to the burner

Correct answer: D

35. A photoelectric cell installed in a boiler burner management system _____.

- A. opens the burner circuit upon sensing a flame failure
- B. detects a flame failure by monitoring radiant heat from glowing refractory
- C. requires mechanical linkage to secure the burner fuel supply
- D. must be bypassed at low firing rates

Correct answer: A

36. The purpose of the mica used in a boiler water gauge glass assembly is to prevent _____.

- A. overheating of the glass
- B. light refraction in the glass
- C. leakage from the glass
- D. etching of the glass

Correct answer: D

37. A boiler safety valve must be capable of _____.

- A. remaining open until all pressure in the steam drum is relieved
- B. opening gradually above a designated pressure
- C. remaining open until a preset pressure drop occurs
- D. closing with a chattering motion to free scale deposits from the seats

Correct answer: C

38. A secondary function of the refractory installed in a marine boiler is to _____.

- A. support the boiler casing
- B. support the burner distance piece
- C. direct the flow of combustion gases
- D. maintain air flow through the burner diffuser

Correct answer: C

39. As the percentage of CO₂ in the stack gas decreases, you can assume that _____.

- A. excess air is increasing
- B. you are approaching secondary combustion
- C. the fuel to air ratio is increasing
- D. fuel is being burned with increasing economy

Correct answer: A

40. Which of the following is the best reason for opening the air cock when draining a water-tube boiler?

- A. Water flows out of the boiler too rapidly with the air cock closed.
- B. With the air cock open, the boiler drains without producing a vacuum.
- C. Air mixed with the water will create a cleansing effect in the tubes.
- D. Air coming into the boiler will help dry out the boiler's surface.

Correct answer: B

41. When cleaning the inside surfaces of the boiler tubes of a water-tube boiler with a powered rotary brush, the brush should be kept in motion to _____.

- A. avoid internal tube damage
- B. reduce wear to brush bristles
- C. reduce tube pitting
- D. prevent it from seizing

Correct answer: A

42. To make temporary emergency repairs to brickwork in a boiler furnace, which of the materials listed should be used?

- A. Calcined diatomaceous earth
- B. Insulating block
- C. Plastic refractory
- D. Air setting mortar

Correct answer: C

43. Which procedure should be followed to dry out the fireside of a boiler after water washing?

- A. Use a wire reinforced steam hose to put superheated steam in the furnace for 6 hours.
- B. Alternately fire one burner for 15-minute intervals during a 5-hour period.
- C. Place trays of silica gel in the furnace.
- D. Open the furnace registers and run the forced draft fans for 3 hours.

Correct answer: B

44. The boiler water gauge glasses should be blown down _____.

- A. when you are in doubt about the water level
- B. every 12 hours of steady boiler steaming operation
- C. when the boiler water level changes in a steaming boiler
- D. twice each day on the midnight and afternoon watches

Correct answer: A

45. Water in the fuel supply to a steaming boiler can be detected by _____.

- A. observation of the fuel oil heater drains
- B. panting of the casing
- C. sputtering of the fires
- D. dense white smoke being observed in the periscope

Correct answer: C

46. Which color burner flame would indicate too much excess air?

- A. Incandescent white
- B. Bright red
- C. Orange red
- D. Yellowish orange

Correct answer: A

47. In a boiler equipped with an automatic feed water regulator, erratic variations in the steam drum water level could be caused by _____.

- A. high feedwater temperature
- B. ruptured feedwater control valve diaphragm
- C. low feedwater temperature
- D. high solids content and foaming in the drum

Correct answer: D

48. Boiler tube failures can result from _____.

- A. overheating
- B. corrosion
- C. mechanical stress
- D. all of the above

Correct answer: D

49. Treatment of boiler feedwater for the control of hardness is necessary to prevent _____.

- A. excessive feedwater alkalinity
- B. foaming
- C. carryover
- D. waterside scale deposits

Correct answer: D

50. Testing boiler water for chloride content will indicate the amount of _____.

- A. dissolved salts from sea contamination
- B. methyl orange that should be added
- C. total alkalinity in the water
- D. phosphates present in the water

Correct answer: A



SE-0001

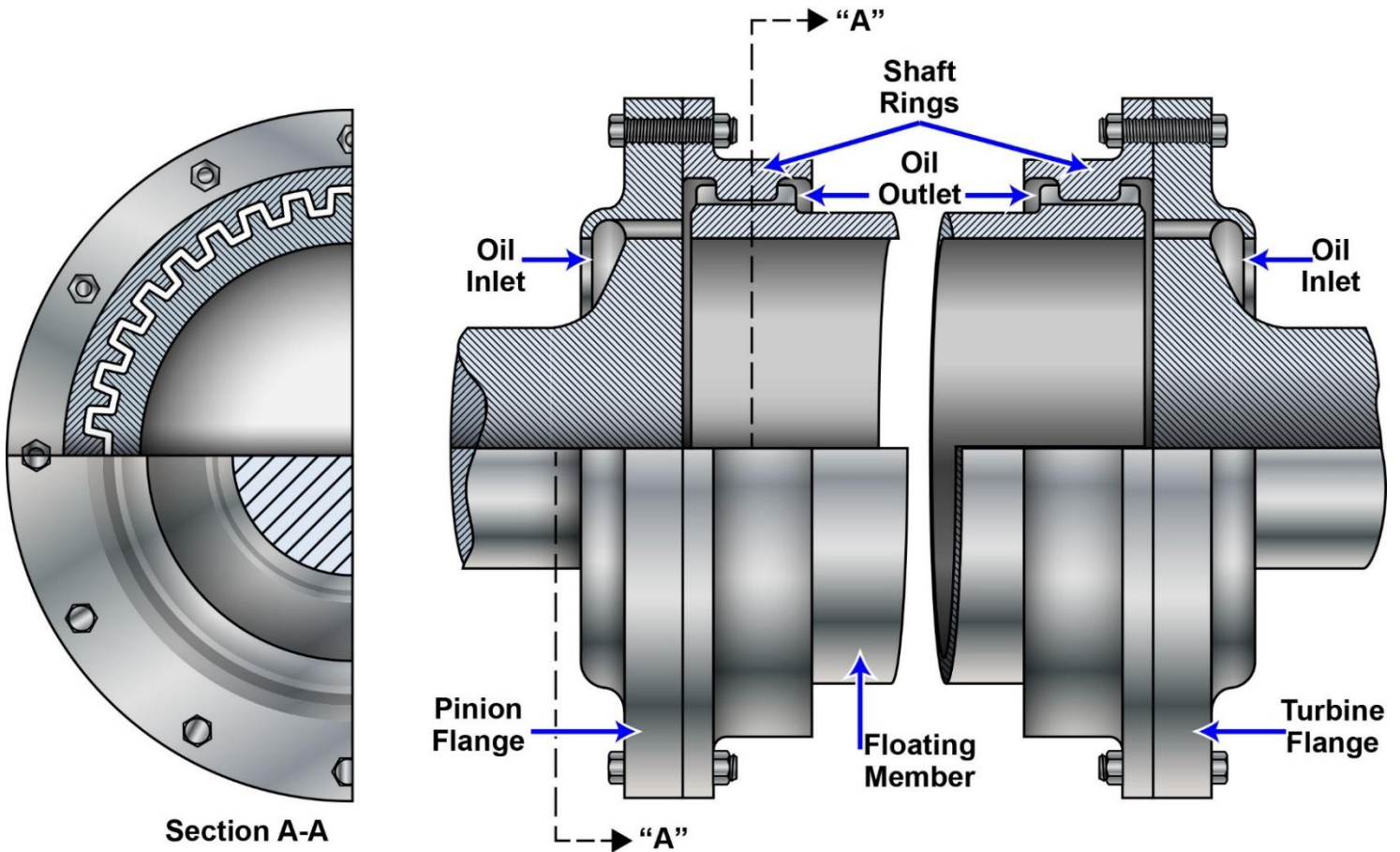

Adapted for testing purposes only BLANK, Introduction to
Naval Engineering, Second Edition
Copyright © 1985 by the United States Naval Institute
Further reproduction prohibited without permission

United States Coast Guard National Maritime Center



SG-0004

Table 1
Thermodynamic Properties of
Saturated Steam (Temperature)

Temp, °F	Absolute Pressure, psi	Enthalpy (BTU/lb) of Liquid	Enthalpy (BTU/lb) of Evaporation	Enthalpy (BTU/lb) of vapor
32	0.08859	0.01	1075.5	1075.5
40	0.12170	8.05	1071.3	1079.3
50	0.17811	18.07	1065.6	1083.7
60	0.25630	28.06	1059.9	1088.0
70	0.36310	38.04	1054.3	1092.3
80	0.50690	43.02	1048.6	1096.6
90	0.69820	57.99	1042.9	1100.9
100	0.94920	67.97	1037.2	1105.2
110	1.27480	77.94	1031.6	1109.5
120	1.69240	87.92	1025.8	1113.7
130	2.22250	97.90	1020.0	1117.9
140	2.88860	107.90	1014.1	1122.0
150	3.71800	117.90	1008.2	1126.1
160	4.74100	127.90	1002.3	1130.2
170	5.99200	137.90	996.3	1134.2
180	7.51000	147.90	990.2	1138.1
190	9.33900	157.90	984.1	1142.0
200	11.52600	168.00	977.9	1145.9
212	14.69600	180.00	970.4	1150.4
220	17.18600	188.10	965.2	1153.4
240	24.96900	208.30	952.2	1160.5
280	49.20300	249.10	924.7	1173.8
300	67.01300	269.60	910.1	1179.7
340	118.01000	311.10	879.0	1190.1
380	195.77000	353.50	844.6	1198.1
400	247.31000	375.00	826.0	1201.0

Table 2
Thermodynamic Properties of
Saturated Steam (Pressure)

Absolute Pressure, psi	Temp, °F	Enthalpy (BTU/lb) of Liquid	Enthalpy (BTU/lb) of Evaporation	Enthalpy (BTU/lb) of vapor
0.5	79.58	47.6	1048.8	1096.4
1.0	101.74	69.7	1036.3	1106.0
5.0	162.24	130.1	1001.0	1131.1
10.0	193.21	161.2	982.1	1143.3
14.7	212.00	180.0	970.4	1150.4
15.0	213.03	181.1	969.7	1150.8
20.0	227.96	196.2	960.1	1156.3
25.0	240.07	208.5	952.1	1160.6
30.0	250.33	218.8	945.3	1164.1
40.0	267.25	236.0	933.7	1169.7
50.0	281.01	250.1	924.0	1174.1
60.0	292.71	262.1	915.5	1177.6
70.0	302.92	272.6	907.9	1180.6
80.0	312.03	282.0	901.1	1183.1
90.0	320.27	290.6	894.7	1185.3
100.0	327.81	298.4	888.8	1187.2
110.0	334.77	305.7	883.2	1188.9
120.0	341.25	312.4	877.9	1190.4
130.0	347.32	318.8	872.9	1191.7
140.0	353.02	324.8	868.2	1193.0
150.0	358.42	330.5	863.6	1194.1
200.0	381.79	355.4	843.0	1198.4
250.0	400.95	376.0	825.1	1201.1
300.0	417.33	393.8	809.0	1202.8
350.0	431.72	409.7	794.2	1203.9
400.0	444.59	424.0	780.5	1204.5

Adapted for testing purposes only
Further reproduction prohibited without permission