

U.S.C.G. Merchant Marine Exam

Chief Engineer – Limited

Q602 Motor Plants

(Sample Examination)

Choose the best answer to the following Multiple-Choice Questions.

1. When inspecting the valve mechanism shown in the illustration, normal maintenance would include _____ . Illustration MO-0074
- A. mechanically adjusting the valve at point "D"
 - B. mechanically adjusting the valve at point "E"
 - C. changing the tappet clearance as measured between points "A" and "B"
 - D. measuring the cold valve clearance between components "C" and "D"

Correct answer: D

2. Decreasing the exhaust valve clearance of a diesel engine will cause the exhaust valve to open _____ .
- A. earlier and have less lift
 - B. earlier and remain open longer
 - C. later and have greater lift
 - D. later and have less duration

Correct answer: B

3. When analyzing indicator card diagrams you are calculating the work output from the cylinder by obtaining the area within the curve of what type of diagram?
- A. temperature/entropy
 - B. pressure/enthalpy
 - C. pressure/volume
 - D. pressure/temperature

Correct answer: C

4. As an engineer of a slow-speed diesel powered vessel, you note that the indicator card diagrams have a flat horizontal profile around TDC. To rectify this, what would be your best course of action?
- A. Reduce the RPM at which the readings are taken.
 - B. Use a spring with a higher spring constant (k value) in the indicator.
 - C. Use a spring with a lower spring constant (k value) in the indicator.
 - D. Increase the RPM at which the readings are taken.

Correct answer: B

5. On a slow-speed diesel engine vessel you are supervising a routine piston pull on a cylinder with 10000 hours on the liner. The piston rod is disconnected. Why must the ridge on the liner be removed before lifting the piston?
- A. The ridge interferes with the piston removal and must be ground down.
 - B. The ridge is an expansion of the exhaust vents that interfere with the piston removal.
 - C. The ridge is part of the exhaust trunk that extends into the path of the piston removal.
 - D. The ridge is a protrusion on the piston crown and must be removed to fit through the liner opening.

Correct answer: A

6. Piston rings are replaced on the cylinder unit of a medium or slow speed diesel engine. All measurements of the cylinder liner and piston are within limits, as is condition of intake/exhaust valves. What is the end result of the ring replacement?
- A. Increased cylinder compression ratio.
 - B. Decreased cylinder clearance volume.
 - C. Increased cylinder compression pressure and efficiency.
 - D. Reduced mechanical wear of the cylinder liner.

Correct answer: C

7. If a valve seat insert, similar to that shown in the illustration is cracked, this may be indicated by _____.
Illustration MO-0043
- A. white vapor in the exhaust gas
 - B. high exhaust pyrometer readings on that particular cylinder
 - C. continuous spring surge
 - D. a jammed indicator cock

Correct answer: A

8. Oil accumulating in the exhaust piping or manifold of a diesel engine can be caused by _____.
A. collapsed hydraulic valve lifters
B. worn valve guides
C. excessive crankcase vacuum
D. excessive lube oil pressure

Correct answer: B

9. One experiences evidence of high temperature corrosion on diesel engine combustion space components. This is exhibited by 'wire drawing' marks on exhaust valves/seats or metal reduction on cylinder heads. What causes this degradation of components?
- A. Excessive combustion temperatures.
 - B. Vanadium, sodium and sulfur in the fuel.
 - C. Improper fuel injection/combustion in cylinders.
 - D. Water contamination of the fuel.

Correct answer: B

10. Before any auxiliary diesel engine hydraulic starting system is opened for servicing or repair, you must _____.
- A. block all hydraulic hoses using high-pressure covers
 - B. bleed off all hydraulic pressure from the system
 - C. ensure that the hydraulic fluid reservoir is full
 - D. place all control levers in the 'HOLD' position

Correct answer: B

11. A diesel engine may fail to start when being cranked, due to _____.

- A. low lube oil viscosity
- B. high cetane number
- C. high lube oil pressure
- D. insufficient compression

Correct answer: D

12. On small diesel engines, a noticeable decrease in the time interval between the replacement of the lube filter cartridge indicates _____.

- A. excessive oil pressure
- B. dirty air filter
- C. excessive oil temperature
- D. piston ring blow-by

Correct answer: D

13. A 'Blotter test' is a test performed on the lube oil of a diesel engine which can determine _____.

- A. the specific gravity of the oil
- B. a change in the oils viscosity
- C. the flash point of the oil
- D. the TBN number of the oil

Correct answer: B

14. A dirty lube oil strainer can result in _____.

- A. crankcase dilution
- B. low bearing oil pressure
- C. excessive oil consumption
- D. low lube oil temperature

Correct answer: B

15. Lube oil in the freshwater cooling system of a diesel engine may result from a _____.

- A. lube oil pump failure
- B. lube oil sump overflow
- C. camshaft seizure
- D. lube oil cooler failure

Correct answer: D

16. For a given fuel, a change in the compression ratio will affect the ignition lag by which of the listed means?

- A. A decrease in compression ratio will decrease the ignition lag.
- B. An increase in compression ratio will increase the ignition lag.
- C. An increase in compression ratio will decrease the ignition lag.
- D. A decrease in ignition lag will increase the compression ratio.

Correct answer: C

- 17.** Catalytic fines comprised of aluminum oxide and/or silicon dioxide are a common contaminant of residual fuels. Which diesel engine components would be most affected by catalytic fines in fuel?
- A. Fuel injectors and piston rings.
 - B. High pressure fuel pumps and fuel injectors.
 - C. Fuel injectors and turbocharger blading.
 - D. High pressure fuel pumps and cylinder liners.

Correct answer: B

- 18.** What physical property of low sulfur distillate fuel can result in operational difficulties?
- A. Lower heat content results in higher fuel consumption.
 - B. Increased viscosity requires additional heating.
 - C. Higher zinc content precipitates out sludge.
 - D. Lack of lubricity in the fuel can result in sticking/scuffing of fuel pump plungers and injector nozzles.

Correct answer: D

- 19.** On a diesel-propelled vessel operating with constant slip what is the effect on fuel consumption with an increase in shaft RPM?
- A. fuel consumption varies as the cube of the shaft RPM
 - B. fuel consumption varies directly proportional to the shaft RPM
 - C. fuel consumption varies as the square of the shaft RPM
 - D. fuel consumption varies inversely with the shaft RPM

Correct answer: A

- 20.** From the graph shown in the illustration, determine the size of the regulating ring required for the proper operation of the fuel oil centrifuge if the fuel oil specific gravity is 0.9 kg/dm³ at 68°F, and the separating temperature is 158°F. Illustration MO-0113
- A. 86 mm
 - B. 104 mm
 - C. 110 mm
 - D. 117 mm

Correct answer: C

- 21.** If the separating temperature is to remain constant, what is the relationship between the specific gravity of the oil and the required size of the regulating ring? Illustration MO-0113
- A. For a constant operating temperature, the greater the specific gravity of the oil the larger the regulating ring.
 - B. With oils of greater specific viscosities it is proper to select smaller regulating rings regardless of the operating temperatures desired.
 - C. The larger sized regulating rings are designed to be used with oils of lower specific gravities.
 - D. The specific gravity of the oil and the size of the regulating ring are related only during the initial design stages of the centrifuge.

Correct answer: C

22. If item "F" begins leaking during operation, which of the following operating conditions will NOT occur?
Illustration MO-0112

- A. The unit will not properly operate and should automatically shut down.
- B. The oil/water interface will remain in the same neutral position.
- C. The water seal will be lost.
- D. The oil/water interface will move outward from the vertical axis of the machine.

Correct answer: B

23. Which of the following conditions would be the most probable cause for the 'low oil temperature after preheater' LED indicators, as shown in the illustration, to be illuminated? Illustration MO-0127

- A. Incorrect steam control valve setting.
- B. Improper steam trap selection.
- C. Too low a temperature in day tank.
- D. Too high a temperature in settling tank.

Correct answer: A

24. When reassembling the bowl of the centrifuge, shown in the illustration, the alignment mark on the locking ring passes the bowl cover mark in excess of the manufacturer's specifications. This is due to _____.
Illustration MO-0012

- A. the disks have not been placed back in the bowl in numerical sequence
- B. the paring devices have been reinstalled in the wrong order
- C. excessive wear of the locking ring and/or bowl threads
- D. too many disks being left out of the bowl during reassembly

Correct answer: C

25. You are testing a closed fuel injection nozzle using a nozzle tester. A pressure slightly less than design valve opening pressure is applied. If no fuel appears at the spray tip, the _____.

- A. nozzle orifices are eroded
- B. nozzle orifices are too small
- C. needle valve spring is defective
- D. needle valve is operating properly

Correct answer: D

26. Because of the close tolerances used in diesel engine fuel oil pumps, a worn plunger requires _____.

- A. highly polishing both the plunger and barrel
- B. grinding the spare plunger to the barrel
- C. replacing the plunger and the barrel
- D. replacing plunger only

Correct answer: C

27. Faulty operation of diesel engine fuel injection nozzles can be a direct result of _____.

- A. excessive fuel nozzle holder cooling
- B. distortion of the fuel spray pattern
- C. sediment in the fuel supply
- D. low lube oil pressure

Correct answer: C

28. Which of the following statements concerning the factors affecting ignition delay is correct?

- A. An increase in combustion chamber turbulence will increase ignition delay.
- B. An increase in coolant temperature will decrease ignition delay.
- C. An increase in intake air temperature will increase ignition delay.
- D. An increase in compression ratio will increase ignition delay.

Correct answer: B

29. Poor combustion in a diesel engine can be caused by _____.

- A. low compression temperature
- B. high scavenge air pressure
- C. low exhaust pressure
- D. high compression pressure

Correct answer: A

30. Problems with the diesel engine fuel injection pump are usually caused by _____.

- A. contaminated fuel
- B. improper adjustment
- C. excessive engine vibration
- D. kinked fuel lines

Correct answer: A

31. While travelling in the tropics, the condensate draining from charge air receiver drain is flowing even though you have raised the inlet temperature to the allowable limit. What effect does excessive moisture have on the engine?

- A. Increased moisture will promote corrosion in the combustion chamber and along the exhaust path.
- B. Increased moisture will improve the combustion.
- C. Increased moisture will have a cleansing effect on the components in the path of the intake air.
- D. Increased moisture in the intake air will dilute the acid in the exhaust trunk.

Correct answer: A

32. A diesel engine operates erratically, overspeeds, and fails to restart when cranked at normal speed. Which of the following problems is the most likely cause for the engine failing to restart?

- A. Failure to reposition the fuel rack
- B. Failure to reset the overspeed trip
- C. Improper governor operation due to excess oil pressure
- D. Damage to the governor due to excessive speed

Correct answer: B

33. What is the maximum allowable clearance permitted between the bearing, shown in the illustration and the shaft along its vertical axis? Illustration MO-0121

- A. 0.30 mm
- B. 0.46 mm
- C. 0.80 mm
- D. 1.00 mm

Correct answer: C

34. When an additional load is applied to a diesel engine which is using an inadequately inflated air bladder clutch unit, you can expect _____.

- A. overheating because of slipping shoes
- B. pneumatic seizure
- C. chipped reduction gear teeth
- D. excessive wear on the thrust bearings

Correct answer: A

35. A diesel-generator governor is hunting. After changing the oil, the governor is flushed and the compensation needle valve is adjusted, but the hunting persists. You should NOW _____.

- A. carefully check for binding in the governor linkage
- B. calibrate the fuel pump rack settings
- C. check air intake manifold pressure
- D. set the speed droop adjustment to zero

Correct answer: A

36. If the compensating needle valve of a hydraulic governor is opened more than necessary the governor will _____.

- A. have a larger than normal deadband
- B. respond slowly to any change in engine load
- C. produce excessive speed response to a load change
- D. stabilize engine speed at the new governor setting

Correct answer: C

37. If the operating speed of a diesel engine increases without an apparent change in the engine control settings, you may suspect a _____.

- A. leaking air starting valve
- B. malfunctioning governor
- C. control air leak
- D. clogged intake air intercooler

Correct answer: B

38. A feed pump for an auxiliary boiler might lose suction if the _____.

- A. boiler water level is low
- B. feedwater is too hot
- C. boiler steam demand is low
- D. feedwater is too cold

Correct answer: B

39. Burner ignition failure in an automatically fired auxiliary boiler would be caused by _____.

- A. a burned-out solenoid in the oil supply valve
- B. high temperature excess air
- C. incorrectly setting the hotwell dump valve
- D. an incorrectly positioned burner snubber relay

Correct answer: A

40. Heavy soot accumulations in an auxiliary boiler could be caused by _____.

- A. water in the fuel oil
- B. excessive cycling
- C. high fuel oil pressure
- D. improper burner maintenance

Correct answer: D

41. The diesel engine shown in the illustration utilizes the type of cylinder construction identified as _____.
Illustration MO-0007

- A. a dry liner
- B. a wet liner
- C. integral with a removable sleeve
- D. integral with a non-removable sleeve

Correct answer: B

42. Which of the following statements is correct concerning the connecting rod and piston assembly shown in the illustration? Illustration MO-0011

- A. The piston pin is bolted to the connecting rod.
- B. The piston has a heat dam.
- C. The piston is free to rotate on the carrier thrust washer.
- D. All of the above.

Correct answer: D

43. Which construction detail is apparent in the connecting rod and piston assembly shown in the illustration?
Illustration MO-0011

- A. The piston is designed with a heat dam.
- B. It is a fork assembly.
- C. The piston is water cooled.
- D. The wrist pin is free floating.

Correct answer: A

44. In accordance with 46 CFR Subchapter J, which of the listed starting aids is acceptable for use with the emergency diesel generator?

- A. Thermostatically controlled electric water jacket heater.
- B. Thermostatically controlled electric oil sump heater.
- C. Heating the starting battery.
- D. Injection of ether into the air intake.

Correct answer: A

45. The device shown in the illustration is classified as a/an _____. Illustration MO-0008

- A. Ringelmann exhaust gas analyzer
- B. exhaust gas vapor condenser
- C. reflective type explosion meter
- D. comparator type mist detector

Correct answer: D

46. If a crankcase explosion due to a hot spot were to occur, the size of the explosion is dependent on which of the following?

- A. The temperature of the hot spot in the crankcase.
- B. The ratio of oil mist to air in the crankcase.
- C. The amount of water in the oil in the crankcase.
- D. The amount of debris in the oil in the crankcase.

Correct answer: B

47. Which of the following is one of the ways to prevent a scavenging fire on a slow-speed diesel engine?

- A. Monitor the main bearing temperatures.
- B. Prevent air from entering the scavenging space.
- C. Keep the scavenging space clean and free of oil.
- D. Shut down the engine if the crankcase mist detector alarm sounds.

Correct answer: C

48. The component labeled as part #20 in the illustration is used to _____. Illustration MO-0050

- A. indicate the quantity of oil flow to the cylinder
- B. prevent the backflow of oil and combustion gases
- C. adjust the timing of the cylinder lubricating oil to the cylinder
- D. meter the amount of oil flow to the cylinder lubricating quill

Correct answer: A

49. Mechanical lubricators for diesel engine cylinders are usually small reciprocating pumps which are _____.

- A. operated manually once each hour
- B. operated until the engine has started
- C. adjustable to meet lubrication requirements
- D. placed into operation only at maximum load

Correct answer: C

- 50.** The area indicated by the letter "W", shown in the illustration is correctly termed the _____. Illustration MO-0112
- A. parting chamber
 - B. closing chamber
 - C. opening chamber
 - D. upper sliding piston chamber

Correct answer: C

- 51.** Which of the following statements is accurate concerning the vibration sensing device used with the separator shown in the illustration? Illustration MO-0127
- A. The vibration switch is sensitive to vibration in a direction horizontal to its mounting base and is normally installed low on the separator where movement is magnified.
 - B. The detector is so arranged to prevent abnormal harmonic frequencies from being developed while the separator is passing through its critical speed range.
 - C. Vibration sensors are not used with centrifuges currently installed on diesel vessels due to excessive vibrations developed by the main propulsion units.
 - D. The detector mechanism consists of an armature suspended on a flexure pivot and restrained from motion by a permanent magnet acting through a small air gap.

Correct answer: D

- 52.** Which of the following precautions should be taken prior to starting the separator shown in the illustration? Illustration MO-0127
- A. Release the bowl brake and confirm proper valve line up.
 - B. Make sure the separator is properly assembled.
 - C. Check for the correct oil level in the gear housing.
 - D. All of the above are correct.

Correct answer: D

- 53.** When changing over from residual to distillate fuel on a slow-speed diesel main engine, what is a good guideline to follow regarding the change over?
- A. Change over should be accomplished as quickly as possible as dictated by engine load.
 - B. Rate of temperature change of fuel to the engine should not exceed 2 degrees C per minute.
 - C. Change over time should not be less than six hours.
 - D. Change over time should not exceed two hours.

Correct answer: B

- 54.** Carbon deposit build up on the injection nozzle orifice is least likely to occur when using which type of fuel injector nozzle?
- A. Hole
 - B. Multi-pintle
 - C. Pintle
 - D. Multi-hole

Correct answer: C

55. Differential needle valves used in fuel injectors are directly closed by _____.

- A. fuel oil pressure
- B. firing pressure
- C. spring force
- D. cam action

Correct answer: C

56. In a turbocharger, inlet air velocity is increased in the _____.

- A. stationary diffuser passages
- B. rotating impeller vanes
- C. inlet nozzle ring
- D. compressor outlet volute

Correct answer: B

57. The device shown in the illustration is used to secure the air supply to a diesel engine when the engine overspeeds. In order for this to occur, supplied oil pressure must _____. Illustration MO-0103

- A. move the piston rod to the left
- B. move the piston rod to the right
- C. decrease allowing the spring to move the piston rod to the right
- D. decrease allowing the butterfly valve to turn counterclockwise

Correct answer: C

58. The pinion gear shown in the illustration, is located _____. Illustration MO-0086

- A. below #1 and #3
- B. between #1 and #3
- C. below #2 and #4
- D. between #2 and #4

Correct answer: B

59. In the reversing reduction gear shown in the illustration, the forward and reverse main pinions are in constant mesh with the main gear. This means the _____. Illustration MO-0085

- A. clutches are engaged by a reduction in control air pressure
- B. synchromesh coupling will maintain transition torque control
- C. set that is clutched in will rotate as idlers driven from the main gear
- D. idling gears rotate in a direction opposite to their rotation when carrying load

Correct answer: D

60. Increasing the oil pressure acting on the power piston of the hydraulic governor shown in the illustration will _____. Illustration MO-0092

- A. require the overspeed trip setting to be adjusted
- B. increase the speed droop
- C. decrease the speed droop
- D. increase the governor output power

Correct answer: D

- 61.** The direct acting mechanical governor used with some small diesel engines, controls fuel flow to the engine by _____.
- A. positioning a butterfly valve in the fuel delivery system
 - B. positioning a servomotor piston attached to the fuel controls
 - C. governor flyweight motion acting on fuel controls through suitable linkage
 - D. governor flyweight action on a pilot valve which controls fuel injection

Correct answer: C

- 62.** Which of the listed problems will happen when the water level of a fire-tube type auxiliary boiler approaches the crown sheet?
- A. Excess steam will be generated.
 - B. The furnace will overheat.
 - C. The fusible plugs will melt.
 - D. The furnace will explode.

Correct answer: C

- 63.** The gauge glass on a coil-type auxiliary boiler is connected to the _____.
- A. surge chamber
 - B. heating coil inlet and outlet
 - C. accumulator
 - D. water softener

Correct answer: C

- 64.** Why should the main steam stop valve of an auxiliary boiler be eased off its seat and then gently closed before lighting off?
- A. To check for a tight bonnet seal.
 - B. To ensure that the valve will not be seized shut when hot.
 - C. To check the valve packing.
 - D. To examine the valve stem for scars or nicks.

Correct answer: B

- 65.** A photoelectric cell installed in an automatically fired auxiliary boiler burner management system _____.
- A. opens the burner circuit upon sensing a flame failure
 - B. detects a flame failure by monitoring radiant heat from glowing refractory
 - C. requires mechanical linkage to secure the burner fuel supply
 - D. must be bypassed at low firing rates

Correct answer: A

- 66.** The part labeled "G", as shown in the illustration, is a _____. Illustration MO-0040
- A. connecting rod bushing
 - B. connecting rod cap
 - C. piston bushing
 - D. bearing shell

Correct answer: A

67. The valve cam slope angle determines the _____.

- A. engine torque characteristics
- B. diameter of intake and exhaust valves
- C. engine fuel efficiency
- D. acceleration rate of valve opening and closing

Correct answer: D

68. In a medium-speed marine propulsion engine equipped with direct admission air starting valves, the cylinders without air starting valves fire first because the _____.

- A. compression is released during starting by opening the exhaust valve
- B. cylinders are not chilled by the expansion of the starting air
- C. operation is under higher compression
- D. fuel is admitted only to these cylinders during cranking

Correct answer: B

69. Which of the following operating characteristics of the Bendix drive friction clutch is associated with a Bendix drive starter?

- A. Disengages the pinion from the flywheel ring gear.
- B. Helps absorb the shock when the pinion engages the flywheel ring gear.
- C. Prevents the pinion starter from overrunning on the starter shaft.
- D. Engages the pinion with the air start distributor.

Correct answer: B

70. The pinion of an auxiliary diesel-electric starting motor normally engages the flywheel ring gear by means of a/an _____.

- A. muff coupling and release
- B. automatic follow-up
- C. magnetic type coupling
- D. Bendix drive or similar mechanism

Correct answer: D



MO-0007

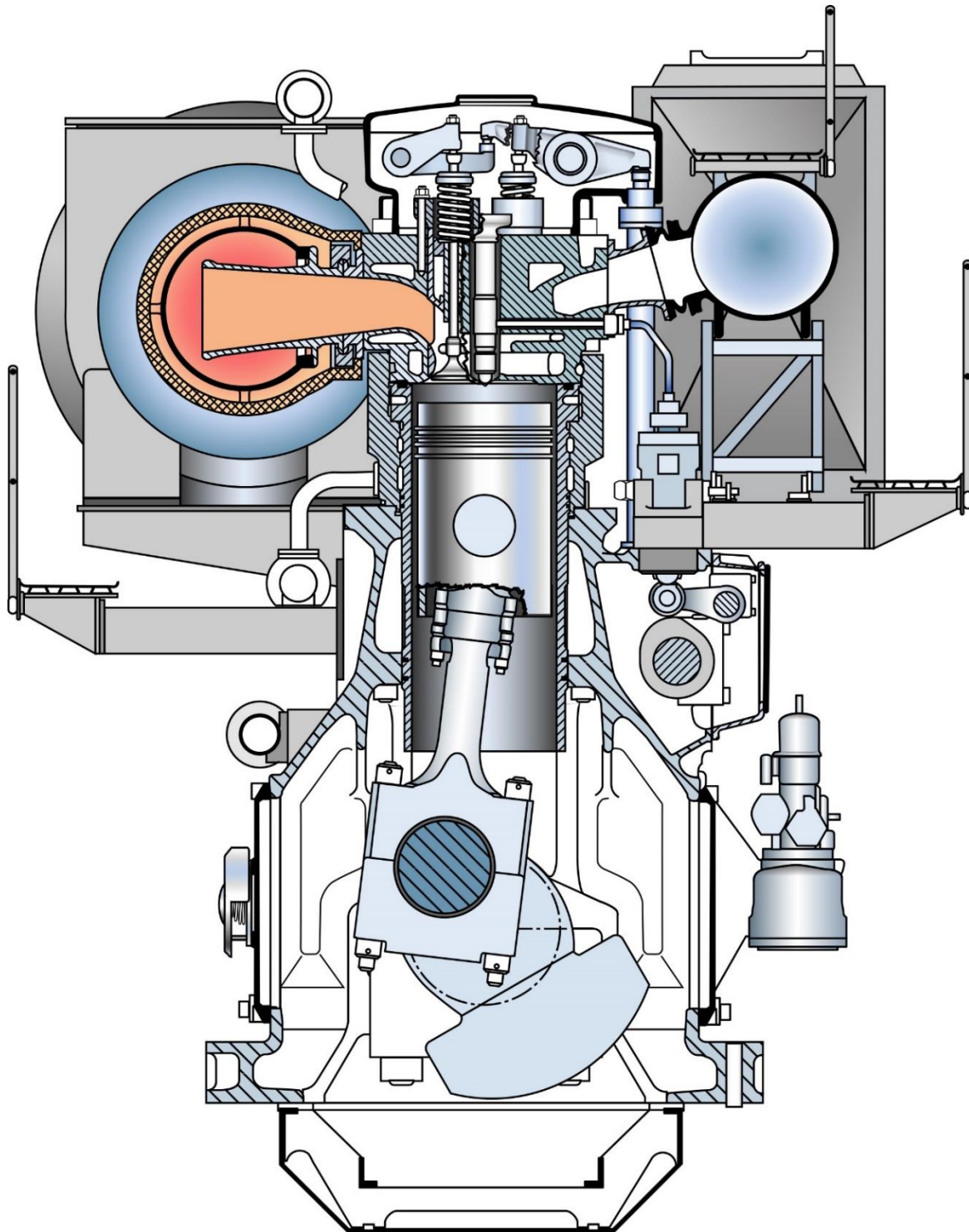

Adapted for testing purposes only from WOODYARD, Pounder's Marine Diesel Engines
and Gas Turbines, Ninth edition
Copyright © 2009 Elsevier Ltd.
Further reproduction prohibited without permission



MO-0008

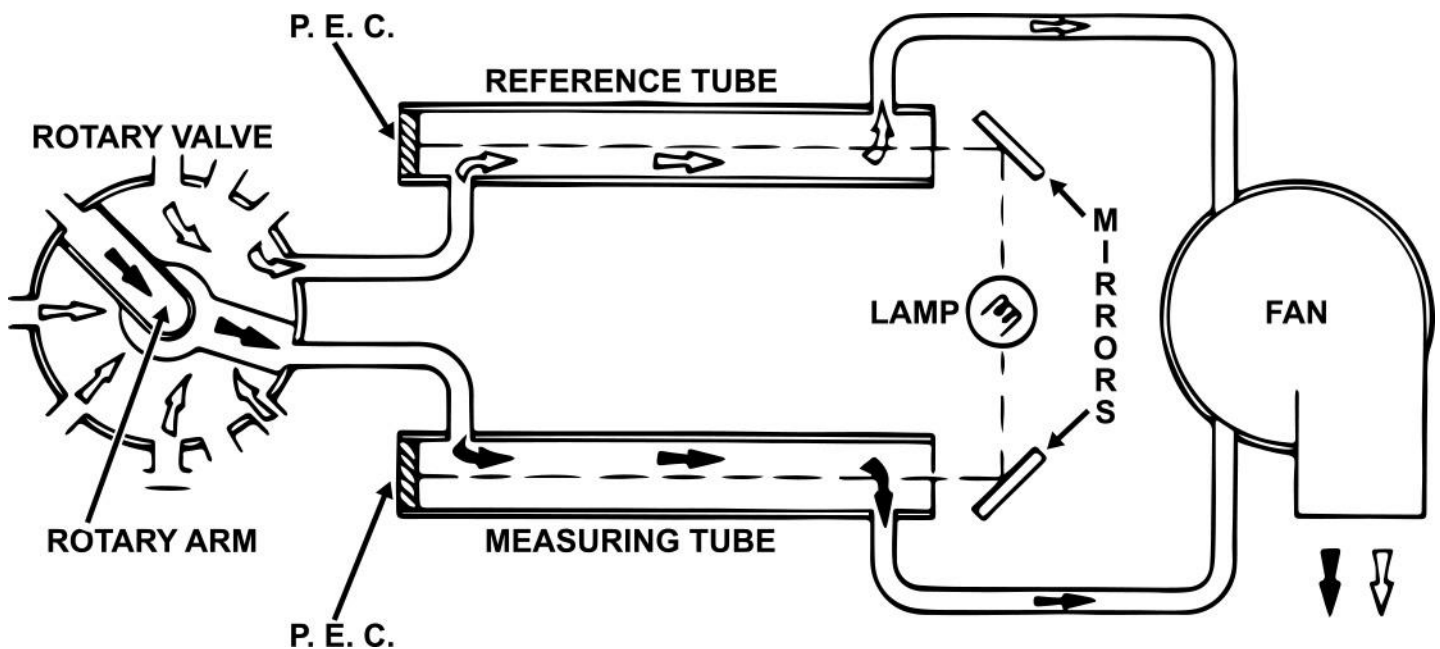

Adapted for testing purposes only from LILY, Diesel Engine Reference Book
Copyright © 1984 by Butterworth and Co. (Publishers) Ltd.
Further reproduction prohibited without permission



MO-0011

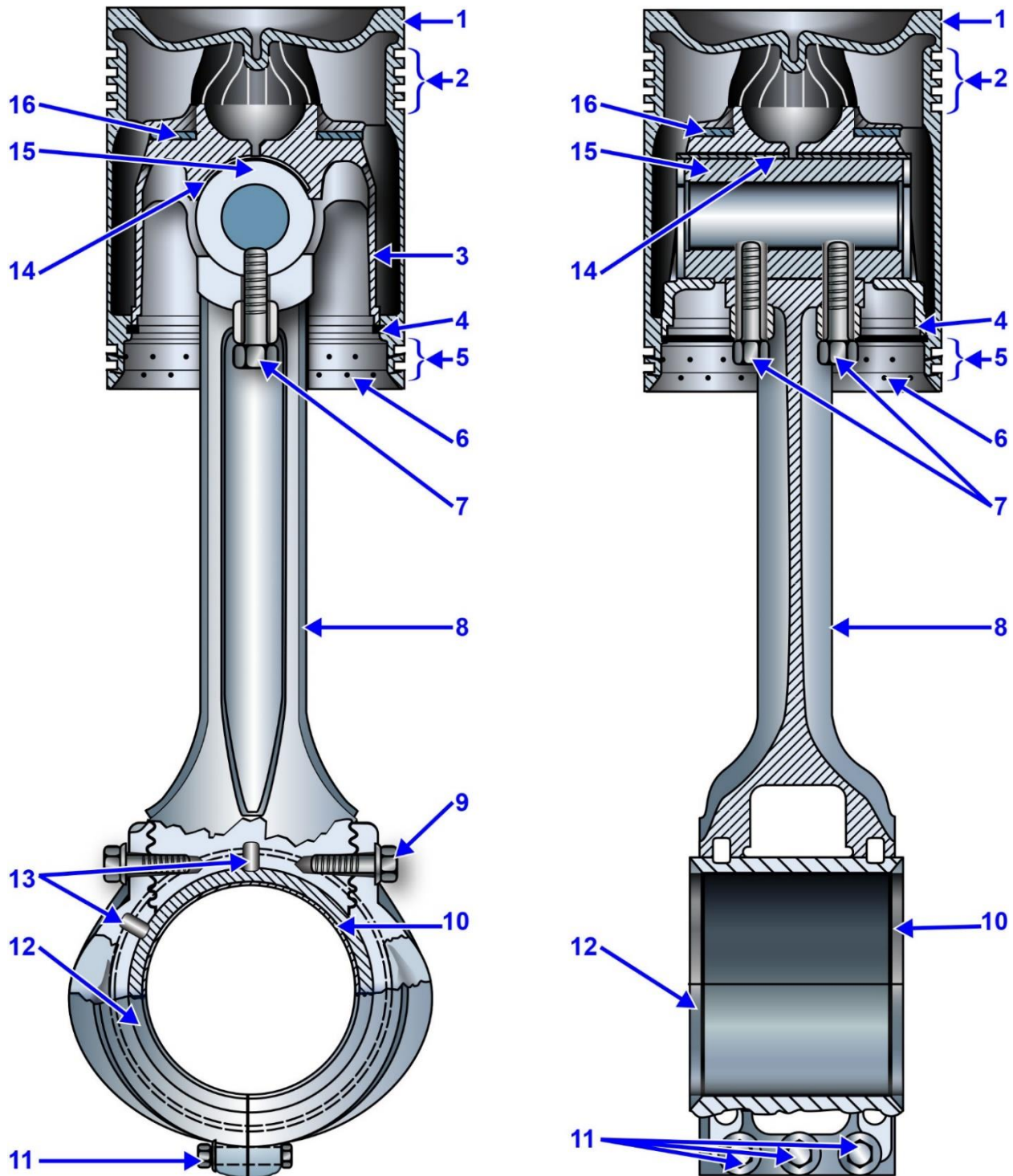

Adapted for testing purposes only from EMD645E9 Engine Maintenance Manual
Copyright © by Electro-Motive Division, General Motors
Further reproduction prohibited without permission



MO-0012

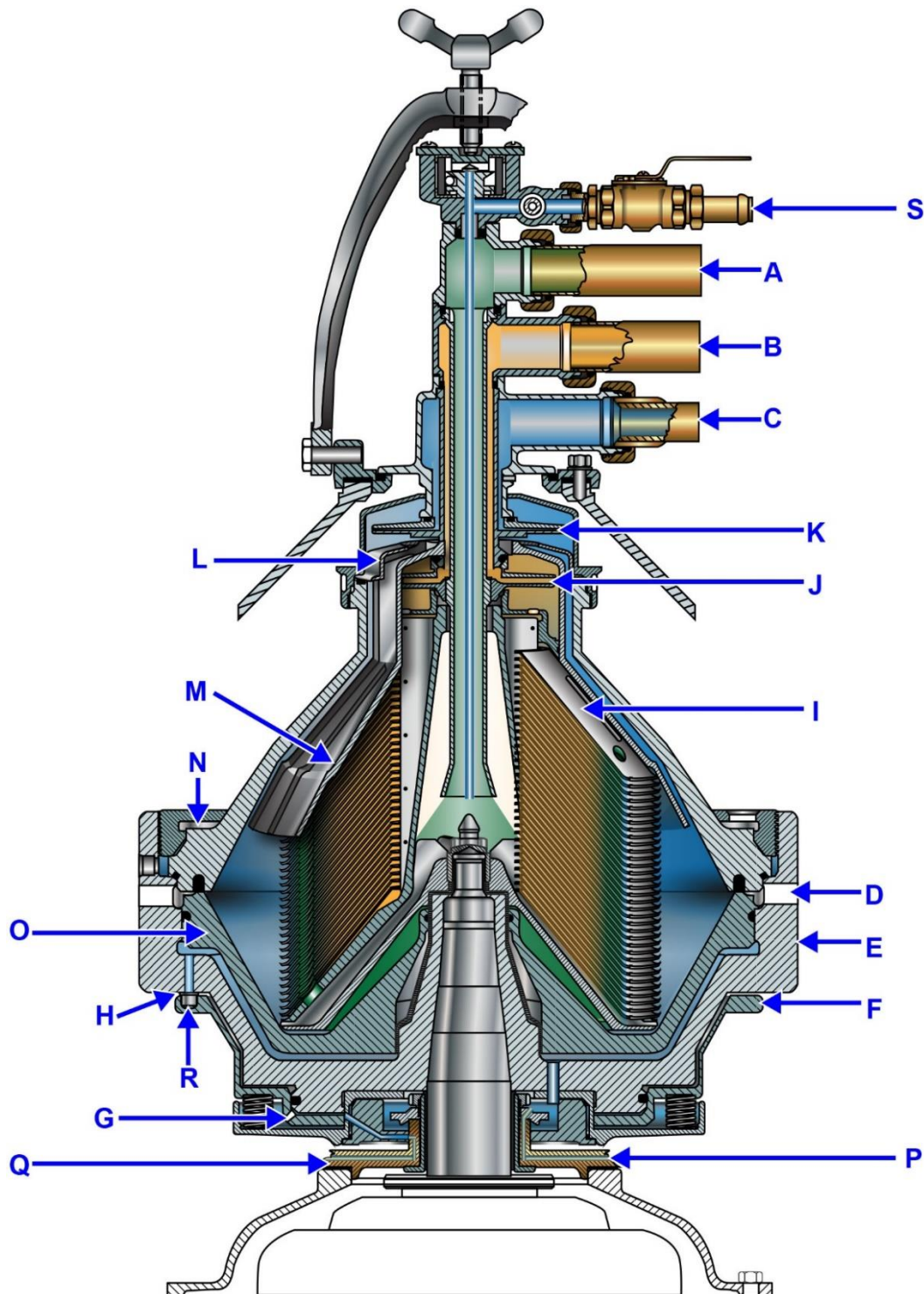

Adapted for testing purposes only from Alfa-Laval MAPX 210TGT-20 Separator Instruction Book
Copyright © by Alfa-Laval
Further reproduction prohibited without permission



MO-0040

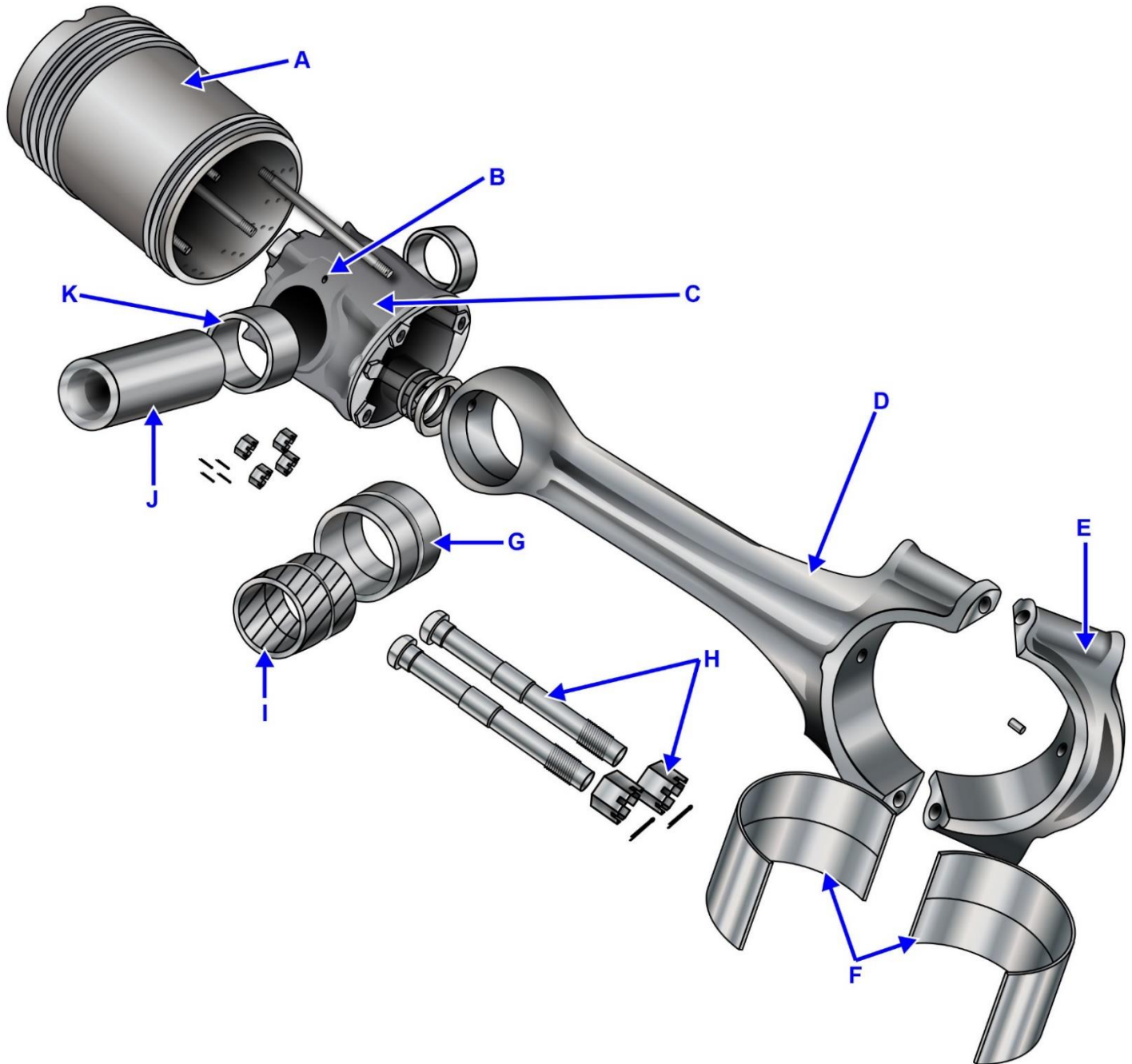

Adapted for testing purposes only from Engineman 3
NAVEDTRA 14331
Further reproduction prohibited without permission



MO-0043

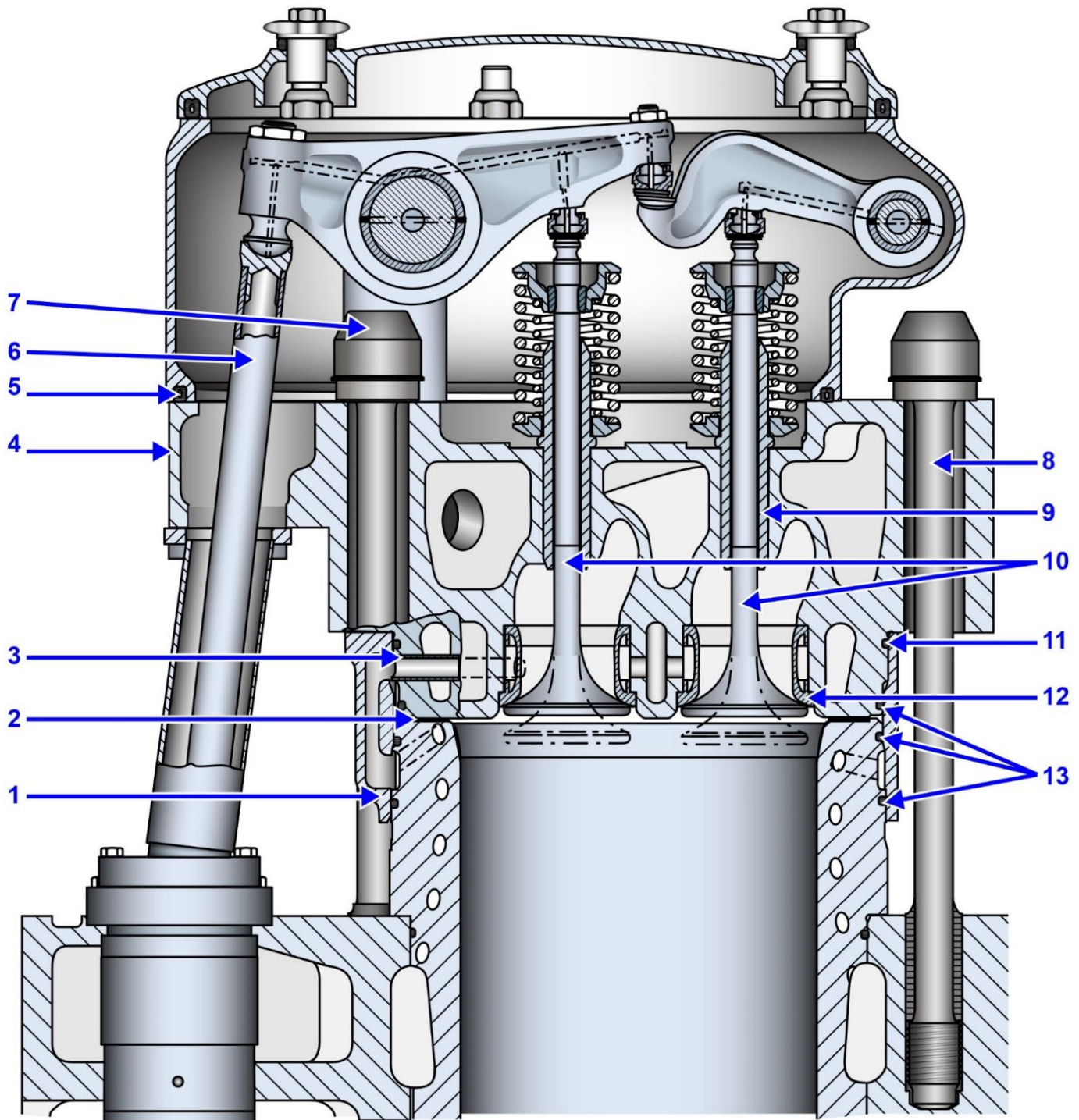

Adapted for testing purposes only from Service Instructions for Sulzer Diesel Engines, type ZL40
Copyright © Sulzer Brothers Limited
Further reproduction prohibited without permission



MO-0050

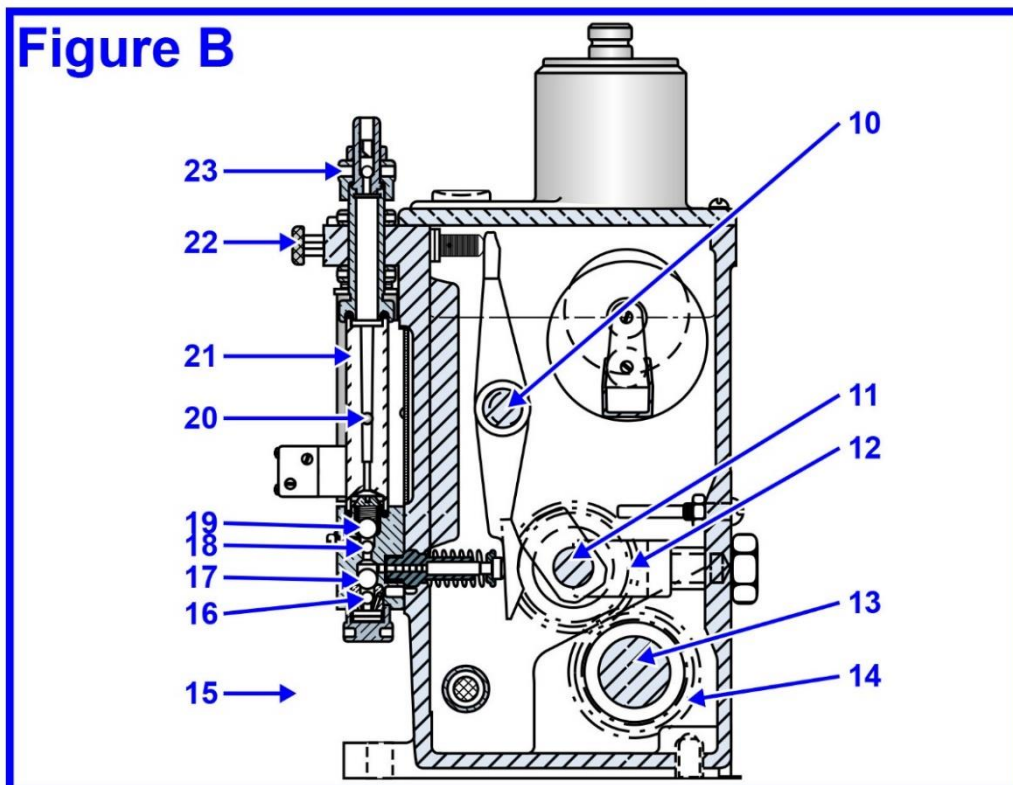
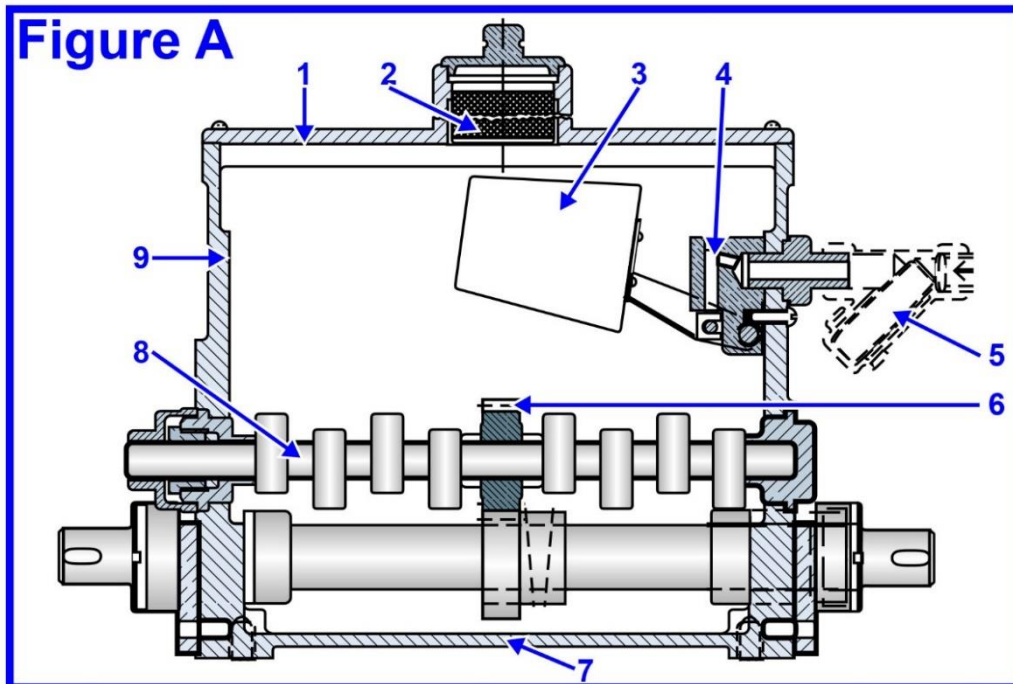

Adapted for testing purposes only from KNAK, Diesel Motor Ships' Engines and Machinery Diagrams
Copyright © by the Institute of Marine Engineers.
Further reproduction prohibited without permission



MO-0074

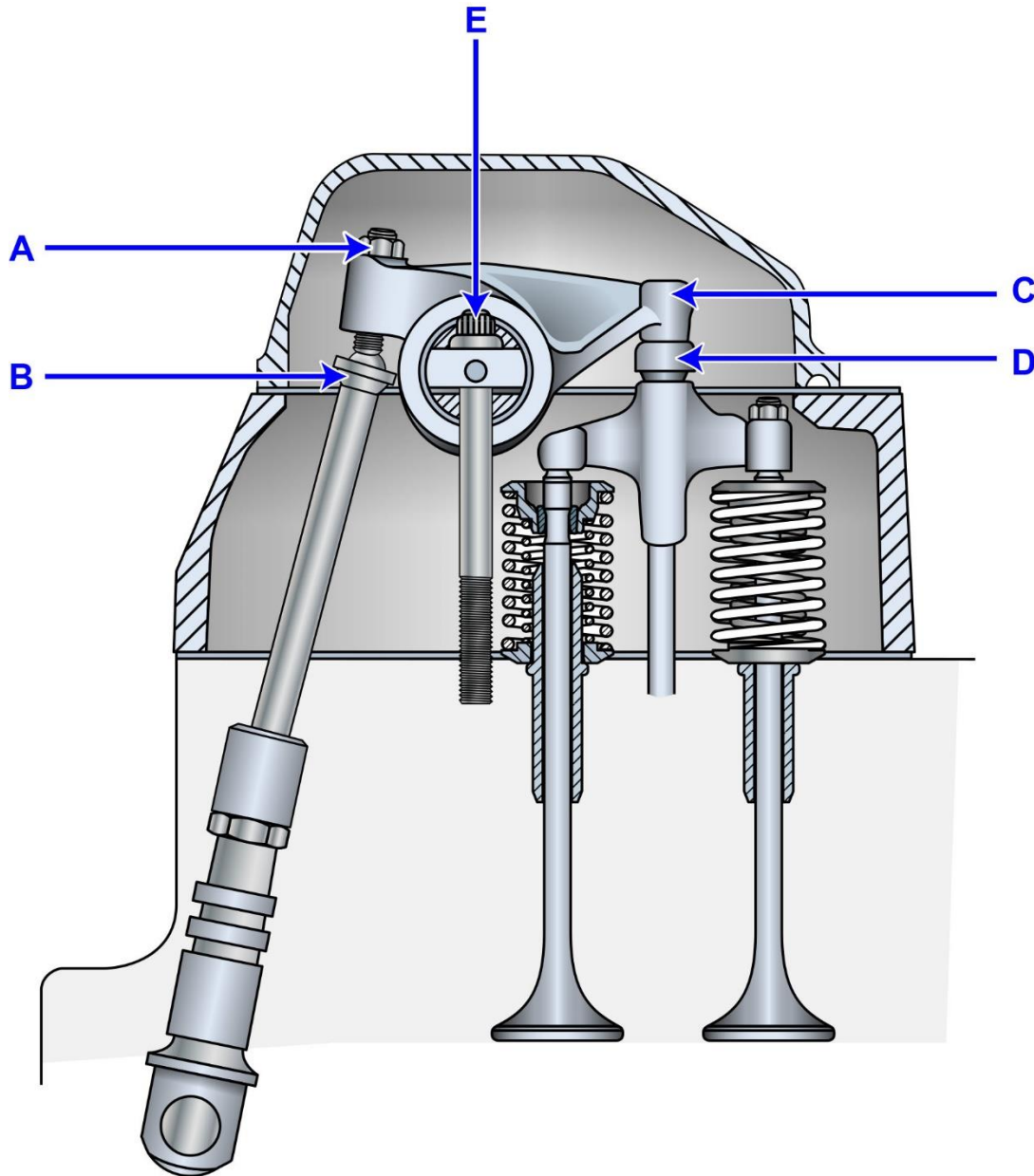

Adapted for testing purposes only from CAT 3500 Series Marine Engine Service Manual, Volume 1
Copyright © 1997 by Caterpillar
Further reproduction prohibited without permission



MO-0085

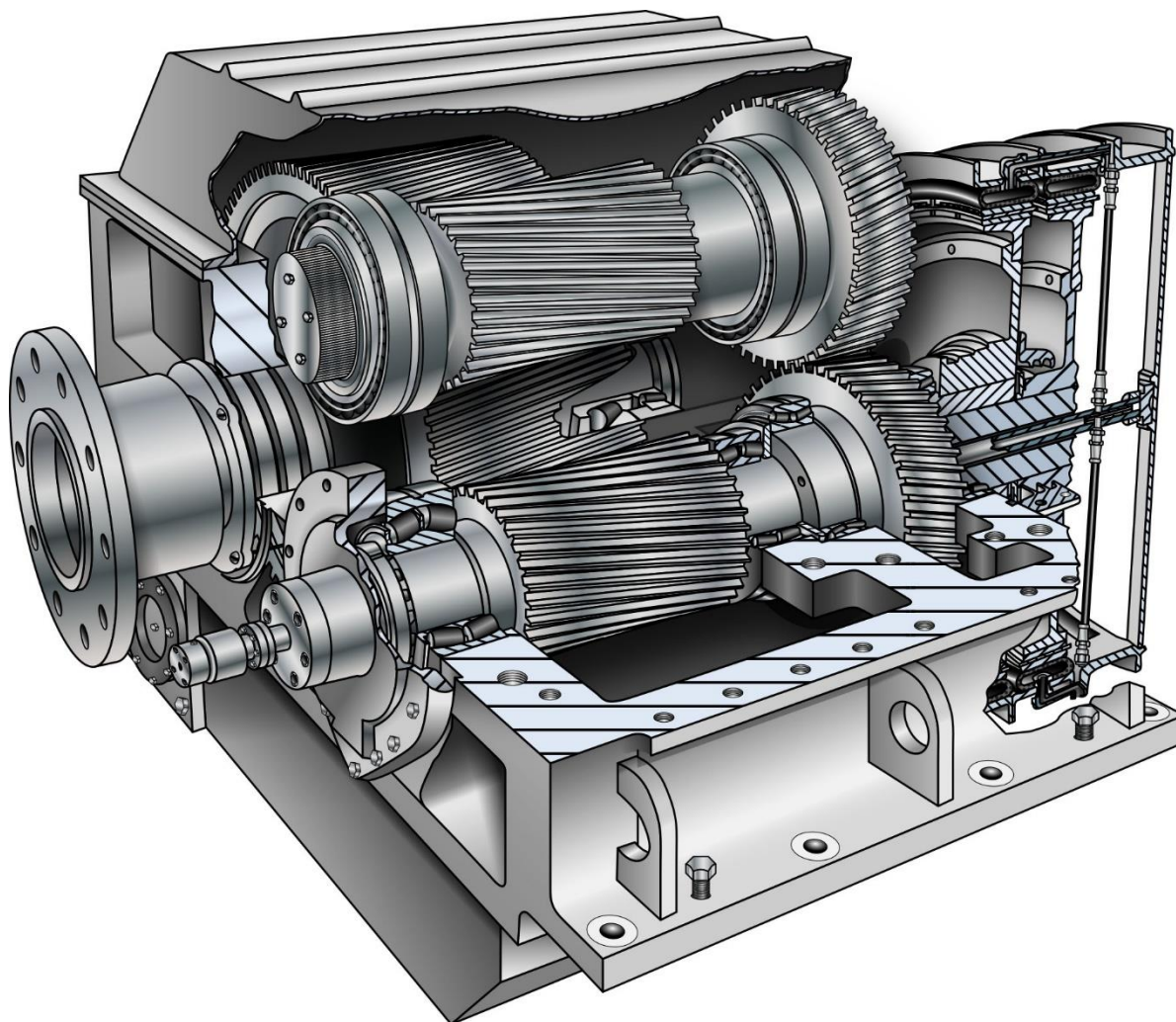

**Adapted for testing purposes only from Falk Marine Reduction Drives,
Installation, Operation and Maintenance Manual
Copyright © Falk
Further reproduction prohibited without permission**



MO-0086

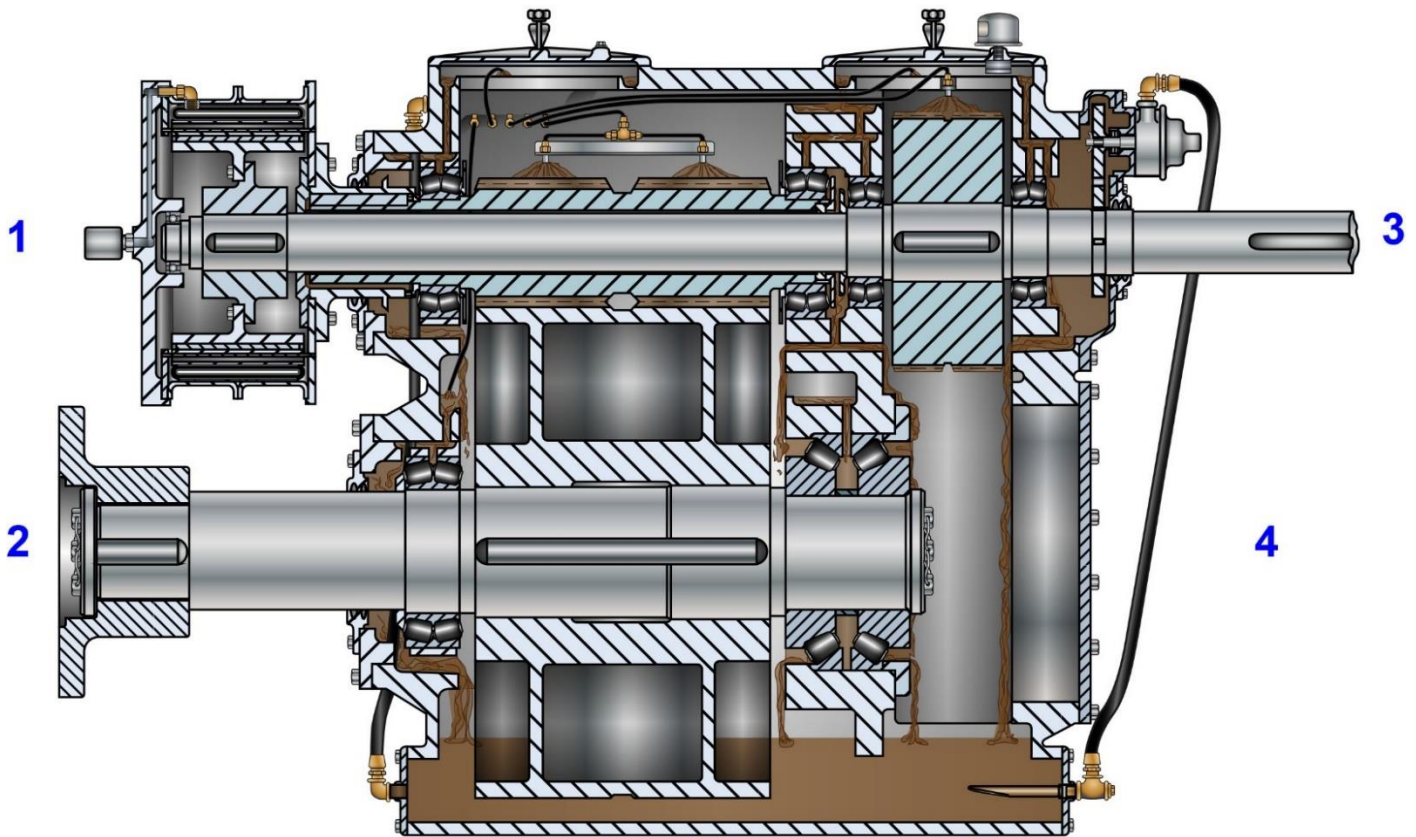

Adapted for testing purposes only from LUFKIN, Marine Gears, Catalog No. MG-77

Copyright © Lufkin Industries, Inc.

Further reproduction prohibited without permission



MO-0092

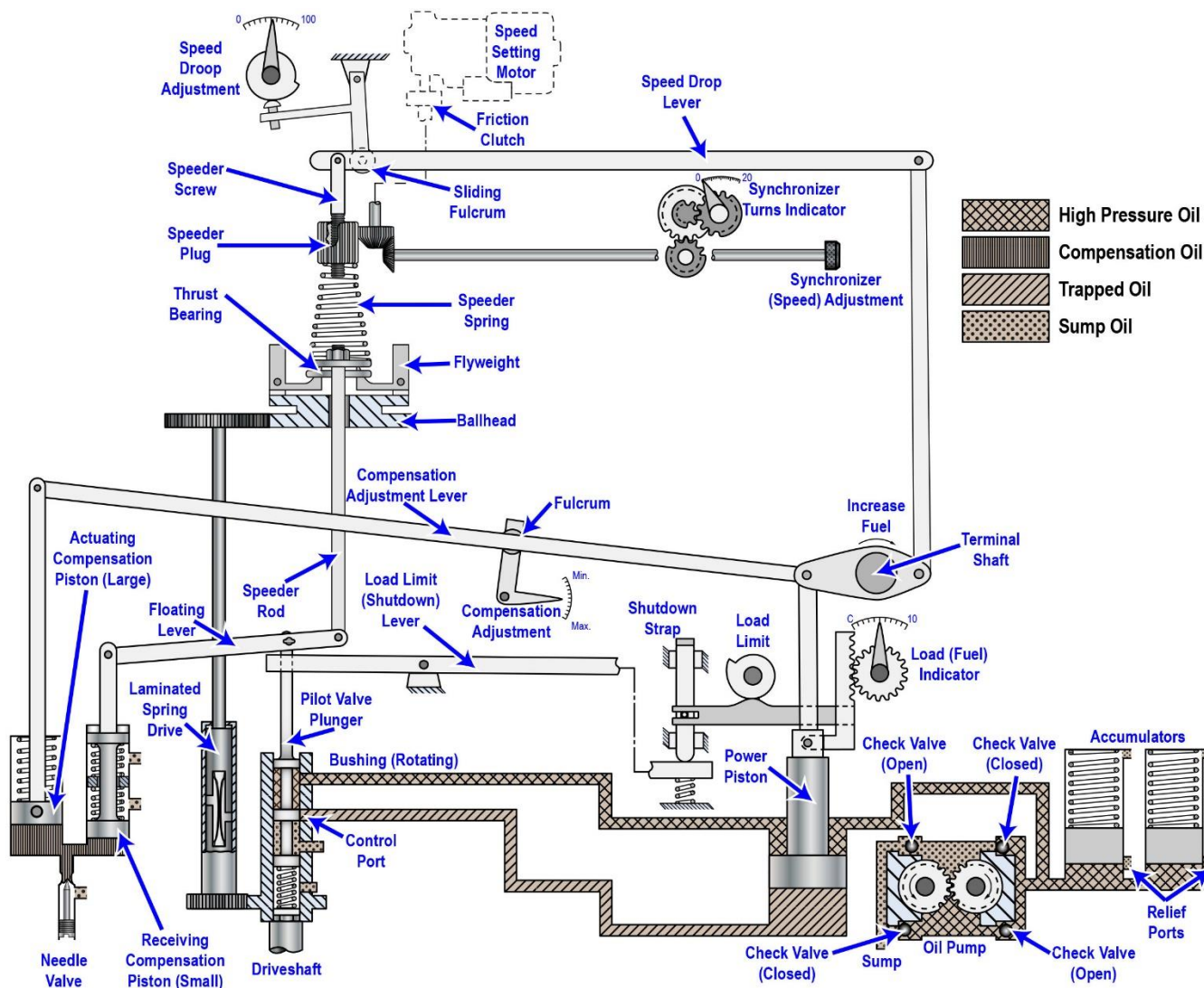

Adapted for testing purposes only from LILLY, Diesel Engine Reference Book
 Copyright © 1984 by Butterworth and Co. (Publishers) Ltd.
 Further reproduction prohibited without permission



MO-0103

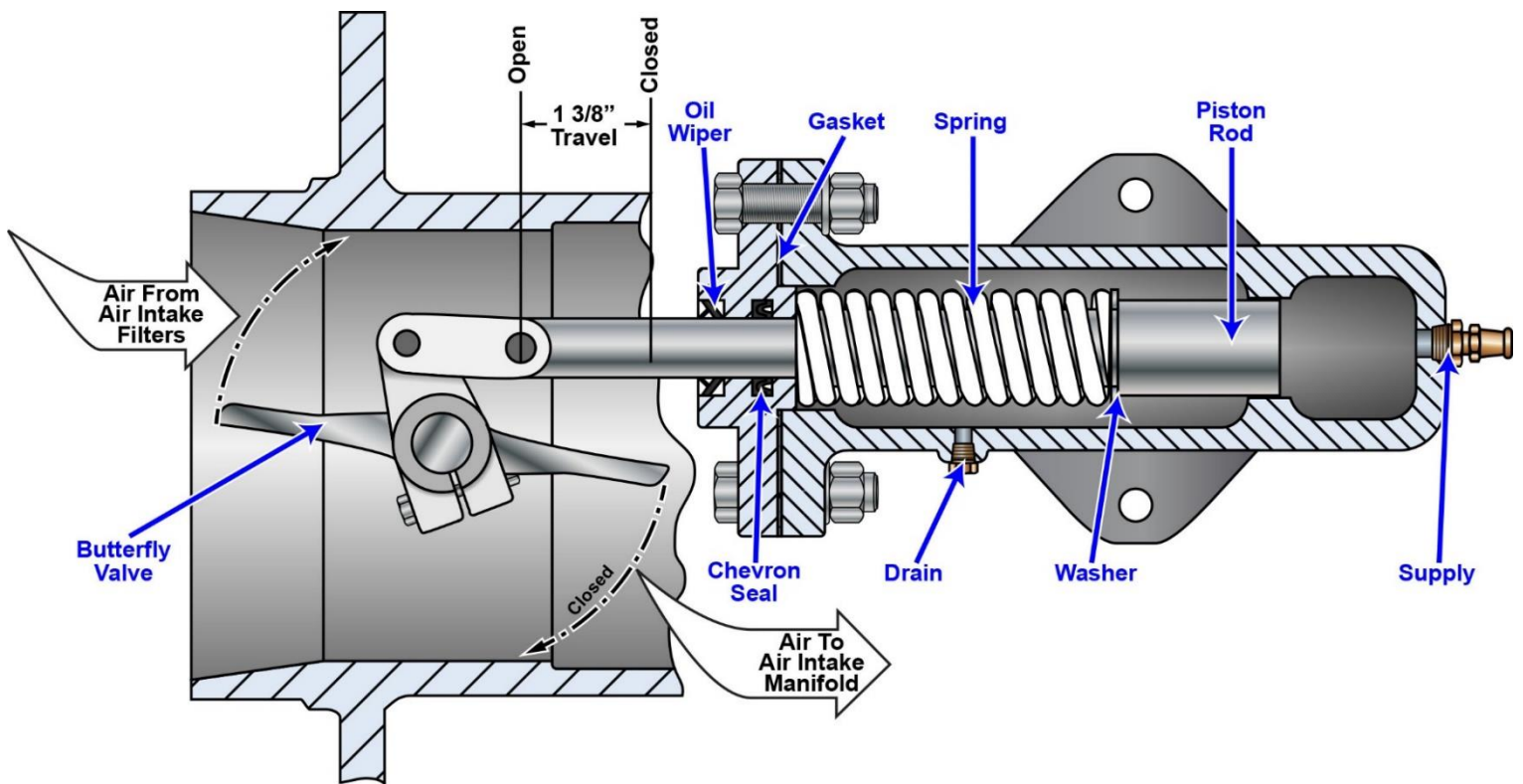

Adapted for testing purposes only
Further reproduction prohibited without permission



MO-0112

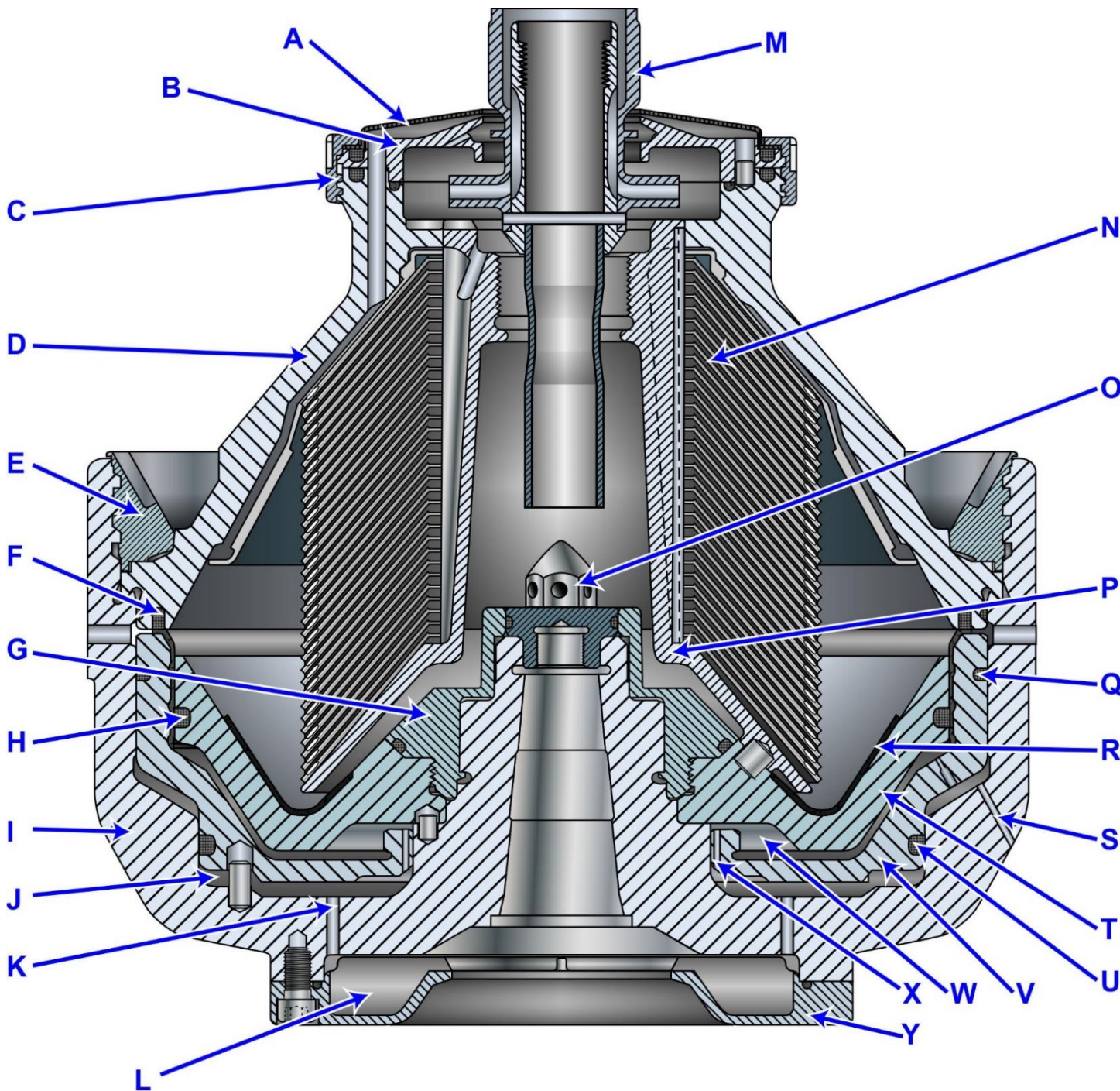

Adapted for testing purposes only from Instruction Manual and Parts List,
Mineral Oil Separator with Self-Cleaning Bowl, Model OSA 20-02-066

Copyright © Westfalia Separator

Further reproduction prohibited without permission



MO-0113

- - - ρ - Water
 ——— ρ - Oil
 Ø - Regulating Ring Size

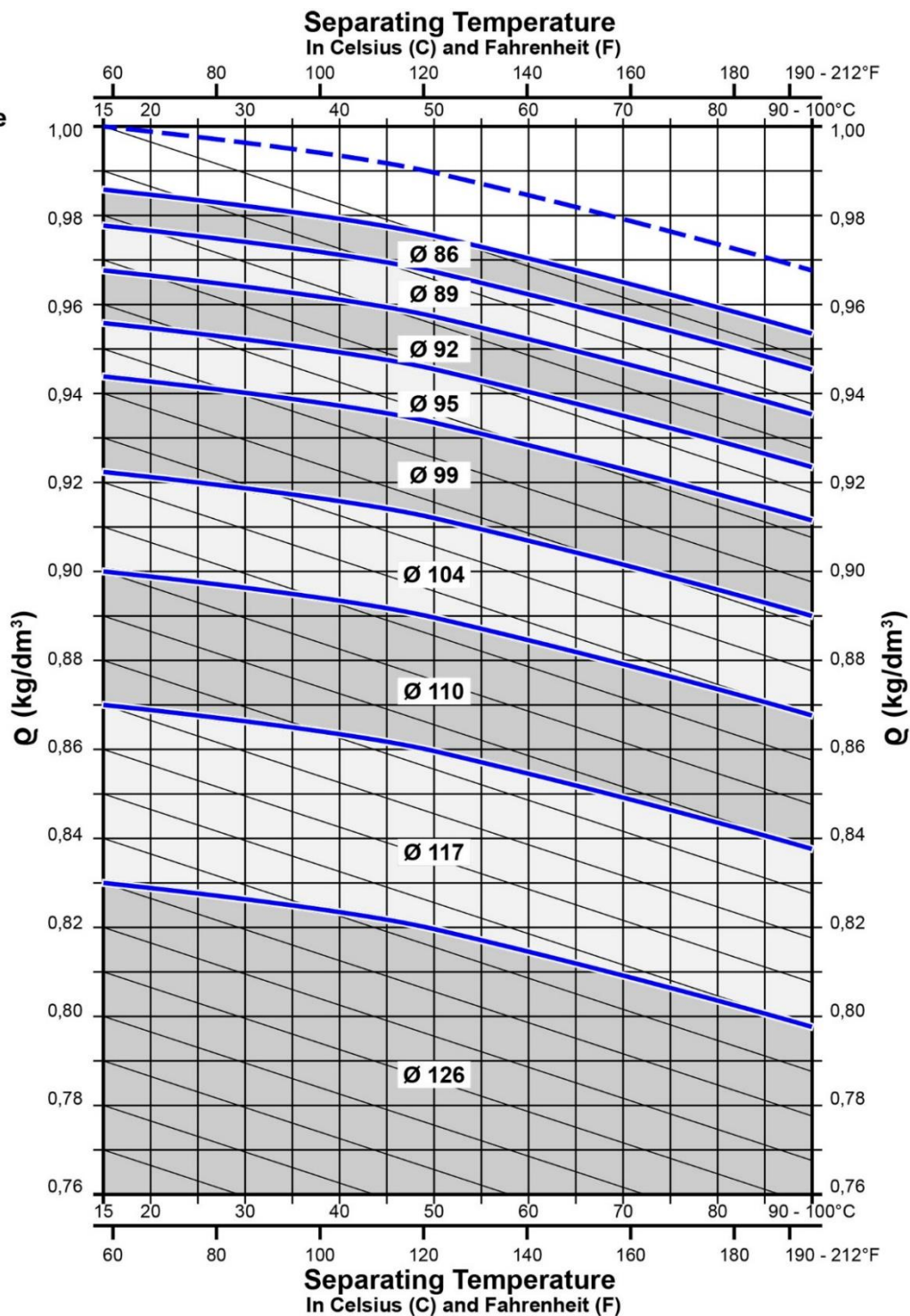

Adapted for testing purposes only from Instruction Manual and Parts List,
 Mineral Oil Separator with Self-Cleaning Bowl, Model OSA 20-02-066
 Copyright © Westfalia Separator
 Further reproduction prohibited without permission



MO-0121

Thrust Bearing

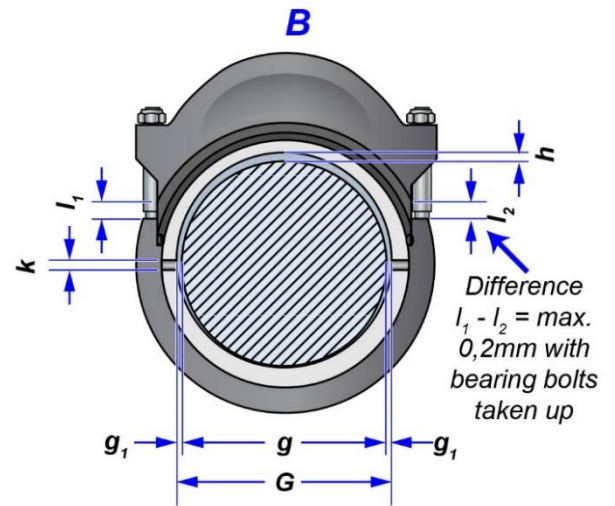
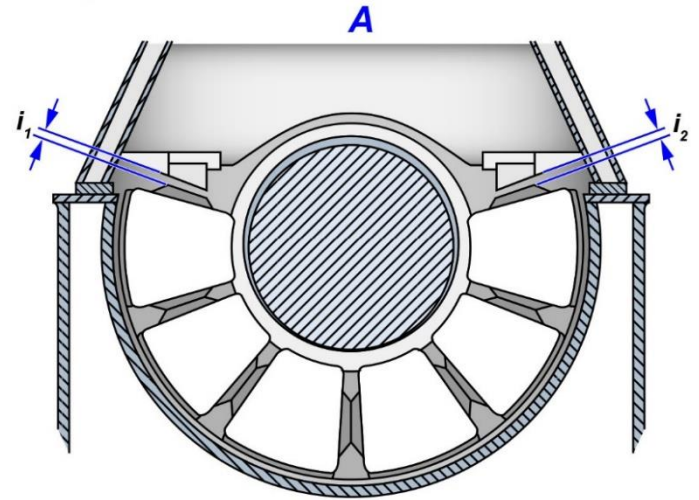
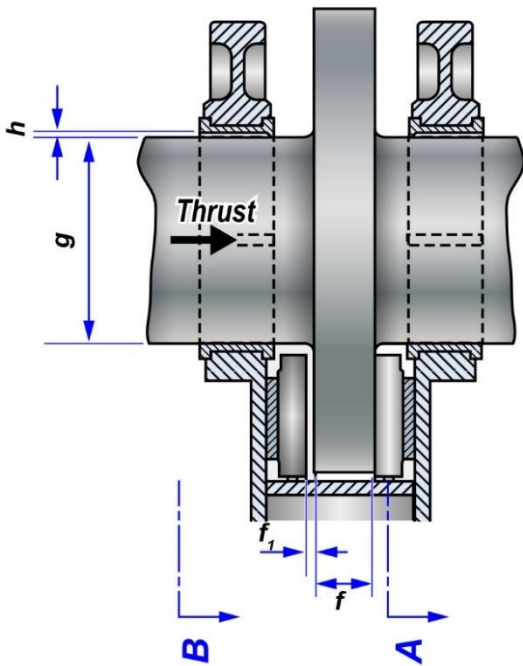

Nominal dimension	Normal play	Max. play (worn)
$f = 200$	$f_1 = 1,0$	2,0
$g = 540 \begin{matrix} +0 \\ -0,08 \end{matrix}$	$g_1 = \text{min. } 0,10$	
$G = 540 \begin{matrix} +0,38 \\ +0,30 \end{matrix}$	$h = \begin{matrix} +0,46 \\ +0,30 \end{matrix}$	0,8
	$i_1, i_2 = 5$	
$k = 20$		

RND 68	Principal Clearances Crankshaft and Thrust Bearing	<i>All dimensions in mm</i>	7 354 366 - E
---------------	---	---------------------------------	----------------------

Adapted for testing purposes only from SULZER, Description of and
Operating Instructions for Sulzer Diesel Engines RND-M
Copyright © Sulzer Brothers Limited
Further reproduction prohibited without permission



MO-0127

EPC Alarm Indications Program Unit			
Alarm from MARST1	Low pressure in oil outlet	High oil temperature after preheater	Low oil temperature after preheater
Emergency stopping or vibrations	No discharge	Logically wrong signal from 1st separator	Remote alarm signal only

MARST1 Alarm Indications Program Unit			
A01	A02	A03	A04
Abnormal water content	Transducer signal minimum value	No discharge feedback signal	Drain valve insufficient
A05	A06	A07	
Micro-processor error	Liquid indication	Transducer fault	

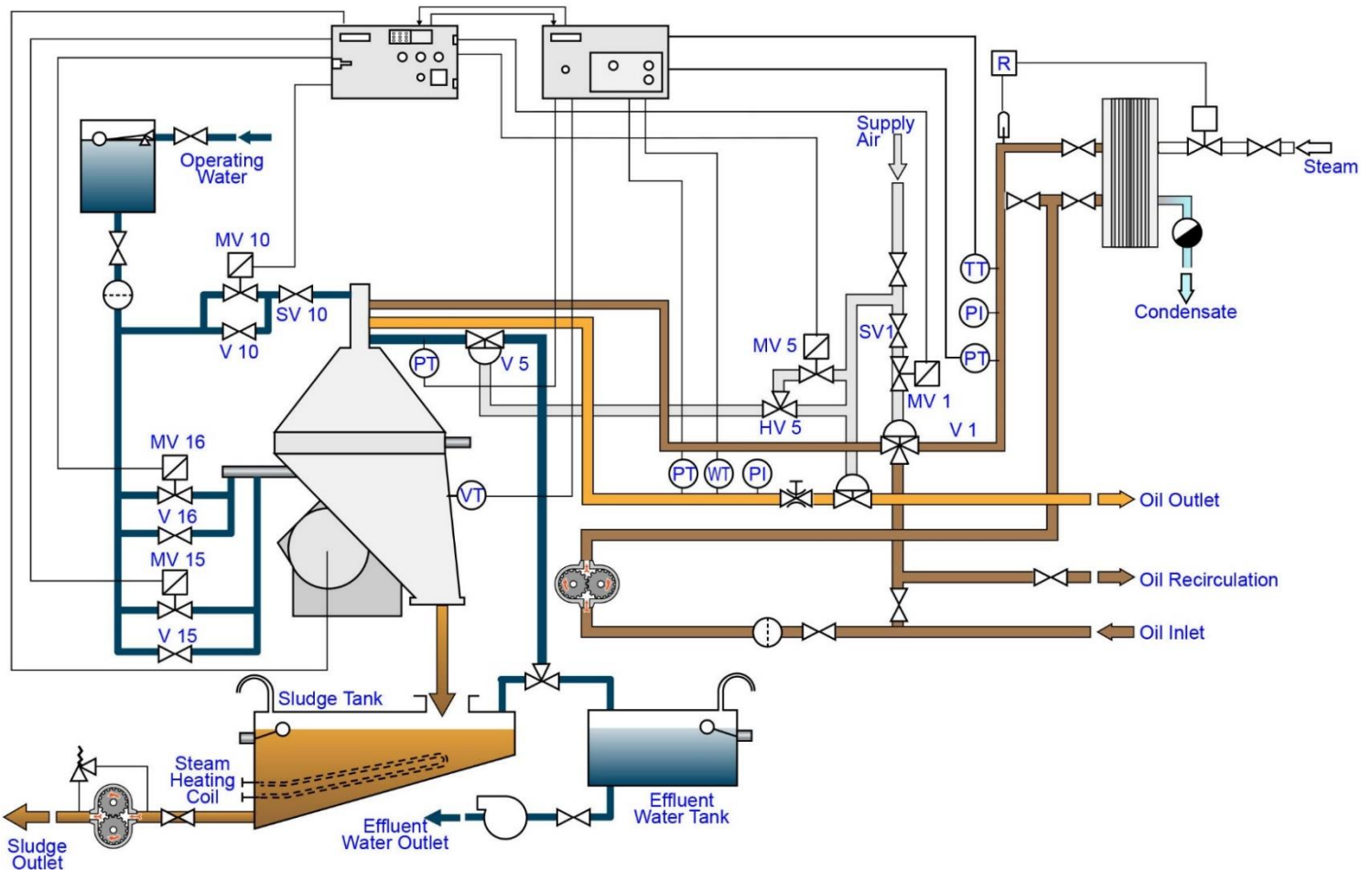

Adapted for testing purposes only from KNAK, Diesel Motor Ships Engines and Machinery, Drawings
 Copyright © 1979 by Christen Knak
 Further reproduction prohibited without permission