



SUB-COMMITTEE ON STABILITY AND  
LOAD LINES AND ON FISHING VESSELS  
SAFETY

51st session  
Agenda item 17

SLF 51/17  
28 August 2008  
Original: ENGLISH

## REPORT TO THE MARITIME SAFETY COMMITTEE

### Table of contents

Section	Page
1 GENERAL	3
2 DECISIONS OF OTHER IMO BODIES	4
3 DEVELOPMENT OF EXPLANATORY NOTES FOR HARMONIZED SOLAS CHAPTER II-1	5
4 REVISION OF THE INTACT STABILITY CODE	12
5 SAFETY OF SMALL FISHING VESSELS	18
6 DEVELOPMENT OF OPTIONS TO IMPROVE EFFECT ON SHIP DESIGN AND SAFETY OF THE 1969 TM CONVENTION	23
7 GUIDELINES FOR UNIFORM OPERATING LIMITATIONS ON HIGH-SPEED CRAFT	27
8 TIME-DEPENDENT SURVIVABILITY OF PASSENGER SHIPS IN DAMAGED CONDITION	28
9 CONSIDERATION OF IACS UNIFIED INTERPRETATIONS	28
10 GUIDANCE ON THE IMPACT OF OPEN WATERTIGHT DOORS ON EXISTING AND NEW SHIP SURVIVABILITY	30
11 STABILITY AND SEA-KEEPING CHARACTERISTICS OF DAMAGED PASSENGER SHIPS IN A SEAWAY WHEN RETURNING TO PORT BY OWN POWER OR UNDER TOW	31

For reasons of economy, this document is printed in a limited number. Delegates are kindly asked to bring their copies to meetings and not to request additional copies.

12	GUIDELINES FOR DRAINAGE SYSTEMS IN CLOSED VEHICLE AND RO-RO SPACES AND SPECIAL CATEGORY SPACES	33
13	GUIDELINES FOR VERIFICATION OF DAMAGE STABILITY REQUIREMENTS FOR TANKERS AND BULK CARRIERS	34
14	WORK PROGRAMME AND AGENDA FOR SLF 52	36
15	ELECTION OF CHAIRMAN AND VICE-CHAIRMAN FOR 2009	38
16	ANY OTHER BUSINESS	39
17	ACTION REQUESTED OF THE COMMITTEE	40

### LIST OF ANNEXES

ANNEX 1	DRAFT MSC RESOLUTION ON EXPLANATORY NOTES TO THE SOLAS CHAPTER II-1 SUBDIVISION AND DAMAGE STABILITY REGULATIONS
ANNEX 2	DRAFT MSC CIRCULAR ON GUIDELINES FOR FLOODING DETECTION SYSTEMS REQUIRED BY SOLAS REGULATION II-1/22-1
ANNEX 3	JUSTIFICATION FOR INCLUSION OF A NEW ITEM ON “REVISION OF SOLAS CHAPTER II-1 SUBDIVISION AND DAMAGE STABILITY REGULATIONS” IN THE SUB-COMMITTEE’S WORK PROGRAMME
ANNEX 4	DRAFT MSC CIRCULAR ON EARLY APPLICATION OF THE INTERNATIONAL CODE ON INTACT STABILITY, 2008
ANNEX 5	ROADMAP TOWARDS ENTRY INTO FORCE OF THE 1993 TORREMOLINOS PROTOCOL
ANNEX 6	PROPOSED REVISED WORK PROGRAMME OF THE SUB-COMMITTEE AND PROVISIONAL AGENDA FOR SLF 52
ANNEX 7	STATUS OF PLANNED OUTPUTS IN THE HIGH-LEVEL ACTION PLAN FOR THE 2008-2009 BIENNIUM RELATING TO THE SUB-COMMITTEE
ANNEX 8	STATEMENT BY THE DELEGATIONS OF SWEDEN AND THE UNITED STATES

## 1 GENERAL

1.1 The Sub-Committee held its fifty-first session from 14 to 18 July 2008 under the chairmanship of Mr. R. Gehling (Australia). The Vice-Chairman, Mr. Z. Szozda (Poland), was also present.

1.2 The session was attended by delegations from the following Member Governments:

ALGERIA	JAPAN
ARGENTINA	LATVIA
AUSTRALIA	LIBERIA
BAHAMAS	MALAYSIA
BELIZE	MARSHALL ISLANDS
BOLIVIA	MEXICO
BRAZIL	NETHERLANDS
CANADA	NORWAY
CHILE	PANAMA
CHINA	PERU
COLOMBIA	PHILIPPINES
CROATIA	POLAND
CYPRUS	PORTUGAL
DENMARK	REPUBLIC OF KOREA
DOMINICAN REPUBLIC	RUSSIAN FEDERATION
ECUADOR	SAINT KITTS AND NEVIS
EGYPT	SAUDI ARABIA
FINLAND	SOUTH AFRICA
FRANCE	SPAIN
GERMANY	SWEDEN
GHANA	SYRIAN ARAB REPUBLIC
GREECE	TURKEY
ICELAND	TUVALU
INDONESIA	UKRAINE
IRAN (ISLAMIC REPUBLIC OF)	UNITED KINGDOM
IRELAND	UNITED STATES
ISRAEL	URUGUAY
ITALY	VENEZUELA

and the following Associate Members of IMO:

HONG KONG, CHINA	FAROE ISLANDS
------------------	---------------

and the following State not Member of IMO:

COOK ISLANDS

1.3 The session was also attended by representatives from the following United Nations specialized agencies:

INTERNATIONAL LABOUR ORGANIZATION (ILO)  
FOOD AND AGRICULTURE ORGANIZATION OF THE UNITED NATIONS (FAO)

1.4 The session was also attended by observers from the following intergovernmental organizations:

EUROPEAN COMMISSION (EC)  
MARITIME ORGANISATION FOR WEST AND CENTRAL AFRICA (MOWCA)

1.5 The session was also attended by observers from the following non-governmental organizations:

INTERNATIONAL CHAMBER OF SHIPPING (ICS)  
INTERNATIONAL TRANSPORT WORKERS' FEDERATION (ITF)  
INTERNATIONAL ASSOCIATION OF CLASSIFICATION SOCIETIES (IACS)  
OIL COMPANIES INTERNATIONAL MARINE FORUM (OCIMF)  
INTERNATIONAL FEDERATION OF SHIPMASTERS' ASSOCIATIONS (IFSMA)  
INTERNATIONAL ASSOCIATION OF INDEPENDENT TANKER OWNERS  
(INTERTANKO)  
INTERNATIONAL MARITIME RESCUE FEDERATION (IMRF)  
CRUISE LINES INTERNATIONAL ASSOCIATION (CLIA)  
INTERNATIONAL PARCEL TANKERS ASSOCIATION (IPTA)  
INTERNATIONAL MARINE CONTRACTORS ASSOCIATION (IMCA)  
THE ROYAL INSTITUTION OF NAVAL ARCHITECTS (RINA)  
INTERNATIONAL TOWING TANK CONFERENCE (ITTC)

### **Opening address**

1.6 The Director, Maritime Safety Division, on behalf of the Secretary-General, welcomed participants and delivered his opening address, the full text of which is reproduced in document SLF 51/INF.8.

### **Chairman's remarks**

1.7 In responding, the Chairman thanked the Director and stated that the Secretary-General's words of encouragement as well as advice and requests would be given every consideration in the deliberations of the Sub-Committee and its working and drafting groups.

### **Adoption of the agenda**

1.8 The Sub-Committee adopted the agenda (SLF 51/1/Rev.1) and agreed, in general, to be guided in its work by the annotations to the provisional agenda contained in document SLF 51/1/1. The agenda, as adopted, with the list of documents considered under each agenda item, is set out in document SLF 51/INF.9.

## **2 DECISIONS OF OTHER IMO BODIES**

### **General**

2.1 The Sub-Committee noted the decisions and comments pertaining to its work made by MSC 83, FP 52, DE 51, STW 39, COMSAR 12, MEPC 57 and MSC 84, and, as reported in documents SLF 51/2, SLF 51/2/1 and SLF 51/2/2, took them into account in its deliberations when dealing with the relevant agenda items.

## **Application of the Committees' Guidelines**

2.2 The Sub-Committee noted that the Committee had agreed that:

- .1 intersessional working groups and technical groups should not be held at the same time as Committee or sub-committee meetings; and
- .2 splinter groups of a working group, if established, should meet outside normal working hours,

and also noted that MSC 84 had noted that the agenda management procedures specified in the Committees' Guidelines should be strictly adhered to. In this regard, the Sub-Committee noted that MSC 84 had revised the Committees' Guidelines (MSC-MEPC.1/Circ.2).

## **Fifty-second session of the Sub-Committee**

2.3 The Sub-Committee was advised (SLF 51/14, paragraph 1) that MSC 84, in pursuance of the request of A 25 to decide on the two sub-committee meetings which will not be held in 2009, taking into account that the sub-total of the sub-committee meeting weeks for 2009 was calculated as seven meeting weeks (not nine meeting weeks), had decided, taking into account the analysis conducted by the Secretariat in consultation with the Committee and Sub-Committee Chairmen for the meeting schedule for 2009 and relevant recommendations of the 2008 Chairmen's Meeting, that SLF 52 should be held in 2010 in lieu of 2009.

## **3 DEVELOPMENT OF EXPLANATORY NOTES FOR HARMONIZED SOLAS CHAPTER II-1**

### **General**

3.1 The Sub-Committee recalled that SLF 50 had re-established the SDS Correspondence Group to develop the final draft text of the Explanatory Notes to SOLAS chapter II-1 subdivision and damage stability regulations, taking into account the Interim Explanatory Notes (MSC.1/Circ.1226); to develop draft Guidelines for flooding detection systems required by new SOLAS regulation II-1/22-1; and to consider the list of the revised SOLAS chapter II-1 regulations identified as needing future improvement.

3.2 The Sub-Committee noted that MSC 84, having agreed to include, in the work programme of the Sub-Committee, a high-priority item on "Damage stability regulations for ro-ro passenger ships", had instructed SLF 51 to give a preliminary consideration to the matter.

3.3 The Sub-Committee also noted that DE 51 had agreed to consult the Sub-Committee with regard to the impact of the revised SOLAS chapter II-1 (provisions relating to subdivision and damage stability) on the Guidelines for ships operating in Arctic ice-covered waters.

3.4 The Sub-Committee had for its consideration the reports of the SDS Correspondence Group (SLF 51/3, SLF 51/3/1 and SLF 51/3/2) submitted by Sweden and the United States; and documents submitted by China (SLF 51/3/6), Germany (SLF 51/3/3), Norway (SLF 51/3/7), IACS (SLF 51/3/4 and SLF 51/3/5) and the Secretariat (SLF 51/16/1).

**Report of the correspondence group on Explanatory Notes to SOLAS chapter II-1**

3.5 The Sub-Committee considered the report of the correspondence group (SLF 51/3), containing the draft text of the definitive Explanatory Notes to SOLAS chapter II-1, developed on the basis of the Interim Explanatory Notes (MSC.1/Circ.1226), together with the following submissions:

- .1 document SLF 51/3/3 (Germany), proposing to make some parts of the Explanatory Notes mandatory under the SOLAS Convention;
- .2 document SLF 51/3/5 (IACS), proposing the basis for an interpretation of the requirement in the revised SOLAS regulation II-1/9, for the double-bottom height under the main engine, and to develop IACS UI for submission to SLF 52;
- .3 document SLF 51/3/6 (China), commenting on the trim range used for calculation of limiting GM curve described in paragraphs 3 and 4 of the revised SOLAS regulation II-1/5-1, and proposing an amendment to the Explanatory Notes; and
- .4 document SLF 51/3/7 (Norway), referring to possible conflict between regulations II-1/13.4 and II-1/8-1.2 of the revised SOLAS chapter II-1, if a machinery space is to be divided longitudinally in order to comply with the redundancy requirement, in particular for small passenger ships.

3.6 Following the discussion, the Sub-Committee approved the report in general and referred the aforementioned documents to the working group for finalization of the draft Explanatory Notes, instructing the group to also prepare the associated draft MSC resolution.

3.7 With regard to the proposal by Germany (SLF 51/3/3) for making parts of the Explanatory Notes (EN) mandatory, the Sub-Committee noted that, while some delegations supported the proposal due to the importance of the uniform implementation of the revised SOLAS chapter II-1 through the EN, other delegations expressed concerns on mandatory status of the EN, at this stage, in view of the need for flexibility of applying the EN and gaining experience with the implementation of the revised SOLAS chapter II-1. Therefore, the Sub-Committee, recognizing the importance of the EN, agreed that the draft MSC resolution, to be adopted at MSC 85, annexing the EN, should emphasize the importance of the EN for ensuring the uniform application of the revised SOLAS chapter II-1. In addition, the Sub-Committee agreed that provisions of the EN that may need to be made mandatory should be considered as part of the work on future improvements of the revised SOLAS chapter II-1.

**Report of the correspondence group on Guidelines for flooding detection systems**

3.8 The Sub-Committee considered the report of the correspondence group (SLF 51/3/1), containing the draft Guidelines for flooding detection systems required by SOLAS regulation II-1/22-1, which also indicated specific text and paragraphs that require further consideration.

3.9 Having noted the concern regarding the quantity of the detection sensors, the Sub-Committee approved the report in general and referred it to the working group for finalization of the draft Guidelines for flooding detection systems.

## **Report of the correspondence group on SOLAS chapter II-1 regulations identified for future improvement**

3.10 The Sub-Committee considered the report of the correspondence group (SLF 51/3/2), providing the list of regulations of the revised SOLAS chapter II-1 identified for possible future improvement, together with document SLF 51/3/4 (IACS), seeking clarification of the requirements concerning pipes piercing the collision bulkheads in the revised SOLAS regulation II-1/12.5.1.

3.11 With respect to the proposal by IACS regarding the use of butterfly valves with pipes piercing the collision bulkheads, the Sub-Committee decided that the working group should further consider whether the proposal should be incorporated in the EN or dealt with in the future amendments, taking into account that the revised SOLAS chapter II-1 applies to both passenger ships and cargo ships and that there is the difference between those ship types in terms of operation and maintenance.

3.12 Subsequently, the Sub-Committee agreed to refer the matter to the working group for further consideration and preparation of the justification for a new item for inclusion in the Sub-Committee's work programme.

### **Matters related to the outcome of MSC 84**

3.13 With regard to the instruction by MSC 84 to give a preliminary consideration to the new work programme item on "Damage stability regulations for ro-ro passenger ships", the Sub-Committee noted (SLF 51/2/2, paragraph 7) that MSC 84 had considered document MSC 84/22/12 (Austria *et al.*), proposing to review the damage stability requirements of the revised SOLAS chapter II-1, to ensure that the issue of water on deck for ro-ro passenger ships is adequately addressed within those requirements, and document MSC 84/22/23 (CESA) which pointed out that the combined use of the revised SOLAS chapter II-1 and the Stockholm Agreement would not be appropriate, as they are based on different concepts, and expressed the opinion that the decision could be taken only after the technical background of the proposal is made available.

3.14 The Sub-Committee, noting the view that further information is necessary and that the relevant studies are being conducted, referred the matter to the working group for further consideration and, in particular, preparation of appropriate draft terms of reference for a correspondence group to enable this matter to be examined in detail.

### **Matters related to the outcome of DE 51**

3.15 The Sub-Committee noted document SLF 51/16/1 (Secretariat), informing that DE 51, having considered documents DE 51/11 (Australia) and DE 51/11/1 (Canada, Germany, United Kingdom and IACS), containing detailed comments on the proposals by the Antarctic Treaty Consultative Parties to amend the Guidelines for ships operating in Arctic ice-covered waters (MSC/Circ.1056-MEPC/Circ.399), set out in document MSC 79/INF.2, had agreed to prepare a complete revision of the Guidelines for ships operating in Arctic ice-covered waters and established a correspondence group to progress the work intersessionally, and had further agreed to consult the SLF Sub-Committee with regard to the impact of the revised SOLAS chapter II-1 provisions on the Guidelines.

3.16 The Sub-Committee noted the specific stability-related issues which might need to be considered are the residual stability criteria following damage assessed under the amended Guidelines; whether any additional subdivision requirements should be added to applicable SOLAS chapter II-1 requirements; and the Guidelines' provisions on double bottoms and protection of spaces containing pollutants.

3.17 Having recognized the importance of the matter, the Sub-Committee agreed that the working group should give preliminary consideration to amending the Guidelines for ships operating in Arctic ice-covered waters, with regard to the impact of the revised SOLAS chapter II-1 provisions on the Guidelines and advise the Sub-Committee as appropriate.

### **Establishment of the working group**

3.18 The Sub-Committee established the Working Group on Subdivision and Damage Stability, and instructed it, taking into account relevant comments made and decisions taken in plenary, to:

- .1 finalize the draft Explanatory Notes to the SOLAS chapter II-1 subdivision and damage stability regulations, together with the associated draft MSC resolution, based on document SLF 51/3, taking into account documents SLF 51/3/3, SLF 51/3/5, SLF 51/3/6 and SLF 51/3/7;
- .2 finalize the draft MSC circular on Guidelines for flooding detection systems required by new SOLAS regulation II-1/22-1, based on document SLF 51/3/1;
- .3 further consider the SOLAS chapter II-1 regulations, identified by the correspondence group for future improvement, based on document SLF 51/3/2, taking into account document SLF 51/3/4, and prepare a justification for a relevant new item for the Sub-Committee's work programme;
- .4 consider matters related to damage stability regulations for ro-ro passenger ships and, in particular, prepare draft terms of reference for a correspondence group (e.g., to consider the problem outlined in document MSC 84/22/12, regarding the safety standards for ro-ro passenger ships under the revised SOLAS chapter II-1, compared with SOLAS '90 and the Stockholm Agreement and, if so, develop possible rectification measures);
- .5 provide comments with regard to the impact of the revised SOLAS chapter II-1 provisions on the stability requirements in the Guidelines for ships operating in Arctic ice-covered waters (MSC/Circ.1056-MEPC/Circ.399), as requested by DE 51; and
- .6 consider whether it is necessary to re-establish the SDS Correspondence Group and, if so, prepare draft terms of reference for the group, for consideration by the plenary.

### **Report of the working group**

3.19 Having received the report of the SDS Working Group (SLF 51/WP.1), the Sub-Committee approved it in general and took action as outlined in paragraphs hereunder.



## **Explanatory Notes to the SOLAS chapter II-1 subdivision and damage stability regulations**

3.20 The Sub-Committee agreed to the Explanatory Notes to the SOLAS chapter II-1 subdivision and damage stability regulations and the covering draft MSC resolution, which had been prepared based on the relevant report of the SDS Correspondence Group (SLF 51/3) and taking into account documents SLF 51/3/3 (Germany), SLF 51/3/5 (IACS), SLF 51/3/6 (China) and SLF 51/3/7 (Norway). The final text of the draft resolution and the Explanatory Notes is set out in annex 1 for submission to MSC 85 for adoption.

3.21 The delegation of Germany stated that they regarded a uniform application of the Explanatory Notes as a crucial prerequisite to implement the safety standard, as defined in the revised SOLAS chapter II-1, uniformly. A respective document SLF 51/3/3 had been presented to the Sub-Committee. This document had been discussed in the group only briefly. The delegation noted that the group had not been willing to follow the German proposal to, firstly, regard the Explanatory Notes as mandatory and, secondly, to identify high-priority specific items to ensure a uniform application of the regulations. Germany reserved its position on the decision of the group and still regarded it as essential for the uniform application of the Explanatory Notes that they should be regarded as an integral part of the new SOLAS chapter II-1. For the delegation of Germany, the issues contained in regulation 4, paragraph 1; regulation 5-1, paragraphs 2, 3 and 4; regulation 7, paragraphs 1 and 2; regulation 7-2, paragraphs 2, 4.1.1, 5.2.1, 5.2.2 and 5.3.1; regulation 7-3, paragraph 2; regulation 9, paragraphs 1, 2, 6, 7, 8 and 9; and regulation 15-1, paragraph 1, are particularly sensitive.

3.22 The Sub-Committee, realizing that some of the drawings in the draft Explanatory Notes contain minor editorial errors which, due to the limited time available, could not be fixed, instructed the Secretariat to correct any such editorials in co-operation with the Chairman of the working group when preparing the final text of the Explanatory Notes.

3.23 In the context of finalizing the text of the draft Explanatory Notes, the Sub-Committee noted that two footnotes in SOLAS chapter II-1 should be amended as follows:

- .1 the footnote to regulation II-1/4.1 should read as follows:
  - “.1 Annex I to MARPOL 73/78, except *combination carriers* (as defined in regulation II-2/3.14) with type B freeboards are not excluded;”;
- .2 the footnote to regulation II-1/13.7.6 should refer to the newer IEC standard IEC 60529:2003 instead of IEC 529(1976),

and invited the Committee to approve the proposed amendments to the footnotes and request the Secretariat to amend these footnotes accordingly in the next consolidated edition of SOLAS.

## **MSC circular on Guidelines for flooding detection systems required by SOLAS regulation II-1/22-1**

3.24 The Sub-Committee agreed to the draft MSC circular on Guidelines for flooding detection systems required by SOLAS regulation II-1/22-1, set out in annex 2, for submission to MSC 85 for approval.

## **SOLAS chapter II-1 regulations needing future improvement**

3.25 The Sub-Committee noted that the group had further considered the SOLAS chapter II-1 regulations identified by the correspondence group as needing future improvement (SLF 51/3/2) but did not change the list at this stage. Subsequently, the Sub-Committee agreed to a justification for the inclusion of a new item on “Revision of SOLAS chapter II-1 subdivision and damage stability regulations” (not for the general revision but for refinement of the revised SOLAS chapter II-1) in the work programme of the Sub-Committee, set out in annex 3, for approval by MSC 85 considering that, if approved, the item should be included in the provisional agenda for SLF 53. In this regard, the delegation of Germany reiterated the views that a discussion on the implementation of SOLAS chapter II-1 and, more particularly, its harmonized implementation would need to be allowed for at the forthcoming session of the Sub-Committee, and, therefore, proposed that the new work programme item as proposed by the working group would need to be taken up at SLF 52. The Sub-Committee did not agree to the proposal and the delegation of Germany reserved its position.

## **Damage stability regulations for ro-ro passenger ships**

3.26 The Sub-Committee considered the matter of damage stability regulations for ro-ro passenger ships, included by MSC 84 as a new item in the work programme of the Sub-Committee, and agreed to establish the SDS Correspondence Group relating to the aforementioned new item under the coordination of Sweden and the United Kingdom\*, and instructed the group, taking into account discussions at SLF 51 and documents MSC 84/22/12 and MSC 84/22/23, to (see also paragraphs 10.6 and 11.5):

- .1 examine the impact of the damage stability requirements of the SOLAS, 2009 amendments on ro-ro passenger ships, in comparison with the SOLAS 90 regulations in association with the Stockholm Agreement;
- .2 define criteria to be used for the evaluation of the two approaches and determine whether the level of safety between them is generally equivalent;
- .3 assess existing and new studies on the subject as well as design experience;
- .4 if it is found that safety levels are not generally equivalent, identify possible rectification measures; and
- .5 submit a report to SLF 52 under the agenda item on “Damage stability regulations for ro-ro passenger ships”.

---

\*

### **Coordinators:**

Mr. Andrew Scott  
 Policy Lead, Stability  
 Ship Safety Branch  
 Maritime and Coastguard Agency  
 Compass House, Tyne Rock  
 South Shields, Tyne & Wear NE34 9PY  
 United Kingdom  
 Tel.: +44 (0)191 496 9905  
 Fax: +44 (0)191 496 9901  
 E-mail: [andrew.scott@mca.gov.uk](mailto:andrew.scott@mca.gov.uk)

Mr. Joakim Heimdahl  
 Swedish Maritime Administration  
 SE-601 78 Norrköping  
 Sweden  
 Tel: +46 40 249 828  
 Mobile: +46 709 198 658  
 E-mail: [joakim.heimdahl@sjofartsverket.se](mailto:joakim.heimdahl@sjofartsverket.se)

3.27 In this connection, the Sub-Committee encouraged all parties that have carried out studies on the subject to forward relevant information to the above correspondence group.

### **Impact of the revised SOLAS chapter II-1 provisions on the stability requirements in the Guidelines for ships operating in Arctic ice-covered waters**

3.28 The Sub-Committee noted that the group had considered stability requirements in the Guidelines for ships operating in Arctic ice-covered waters referred to it by DE 51, regarding the stability requirements following the probabilistic concept to be included in a revision of those Guidelines currently under preparation, taking into account further information on the issue presented by the coordinator of the DE Sub-Committee correspondence group.

3.29 The Sub-Committee noted the following comments made within the group related to the matter:

- .1 the probabilistic damage and subdivision provisions in SOLAS chapter II-1 were developed assuming collision damage in a moderate sea state. Ice damage is a different issue and there are no statistics available to allow the development of survival criteria for such damage. However, new regulation II-1/8 (Special requirements concerning passenger ship stability), which is deterministic in nature, covers side damage and might be useful;
- .2 the use of intact stability criteria for a damaged ship instead of damage stability criteria would result in a much higher standard since this would basically require damaged ships to maintain the same stability as intact ships; and
- .3 the wave height, which is essential for survival criteria, in ice-affected waters may be dependent on the ice concentration,

and requested the Secretariat to forward these comments to the relevant DE Sub-Committee correspondence group.

3.30 The Sub-Committee also invited stability experts to contribute to the work of the DE Sub-Committee correspondence group\*.

### **Establishment of a Correspondence Group**

3.31 The Sub-Committee noted the group's opinion that, with the finalization of the Explanatory Notes, the work on agenda item 3 (Development of Explanatory Notes for harmonized SOLAS chapter II-1) has been completed and, therefore, there is no need for a correspondence group under the agenda item.

---

\* **Coordinator:**  
Mr. Victor M. Santos-Pedro  
Director, Design, Equipment and Boating Safety  
Marine Safety (AMSR)  
330 Sparks Street, Ottawa  
Ontario, Canada, K1A 0N8  
Tel: +1 613 991 4818  
E-mail: [santos@tc.gc.ca](mailto:santos@tc.gc.ca)

## **Completion of the work programme item**

3.32 In view of the above developments, the Sub-Committee invited the Committee to delete the item from its work programme.

## **4 REVISION OF THE INTACT STABILITY CODE**

### **GENERAL**

4.1 The Sub-Committee recalled that SLF 50 had re-established the IS Correspondence Group to continue to work on the items contained in the updated plan of action for intact stability work (SLF 50/WP.2, annex 6), and had invited the Committee to extend the target completion date of the item to 2010.

4.2 The Sub-Committee also recalled that SLF 50 had decided to draft an MSC circular on early implementation of the 2008 IS Code at this session, with a view to its approval by the Committee simultaneously with the adoption of the Code at MSC 85.

4.3 The Sub-Committee noted that MSC 83 had approved the draft International Code on Intact Stability, 2008 (2008 IS Code) and the associated draft amendments to the 1974 SOLAS Convention and the 1988 LL Protocol to make the 2008 IS Code mandatory, with a view to adoption at MSC 85.

4.4 The Sub-Committee also noted that MSC 83 had approved, in principle, the draft MSC circular on Explanatory Notes to the International Code on Intact Stability, 2008, with a view to its formal approval at MSC 85 simultaneously with the adoption of the IS Code.

4.5 The Sub-Committee had for its consideration the report (part 2) of the IS Working Group at SLF 50 (SLF 51/4), the report of the IS Correspondence Group (SLF 51/4/1) submitted by Germany; and documents submitted by Germany (SLF 51/4/4 and SLF 51/INF.3), Japan (SLF 51/4/3), Poland (SLF 51/4/5), the United Kingdom (SLF 51/4/2 and SLF 51/INF.2), the United States (SLF 51/INF.4) and RINA (SLF 51/INF.6).

### **REPORT OF THE CORRESPONDENCE GROUP**

#### **Ships with large B/D ratio**

4.6 The Sub-Committee considered a part of the report of the correspondence group (SLF 51/4/1), explaining the discussion on ships with large B/D ratio in the correspondence group, together with document SLF 51/4/2 (United Kingdom), which provided the results of a research project, modelling three domestic passenger ships and investigating the influence of the still water GZ parameter angle of peak GZ, where the angle of peak GZ parameter is compared with other stability parameters currently in use. Following brief discussion, the Sub-Committee referred the matter to the working group for further consideration.

#### **Weather criteria**

4.7 The Sub-Committee, having considered a part of the report of the correspondence group (SLF 51/4/1), containing information on experience on the reduction of the pressure P to be used in the application of weather criterion, together with document SLF 51/INF.2 (United Kingdom) which provided the results of a research project investigating severe wind and rolling criterion (weather criterion) using physical modelling of five domestic ships to determine rolling angle in waves and in which some suggestions for amending the parameters were discussed, referred the matter to the working group for further consideration.

### **New generation intact stability criteria**

4.8 The Sub-Committee considered the report (part 2) of the IS Working Group at SLF 50 (SLF 51/4) and parts of the report of the correspondence group (SLF 51/4/1), relating to the new generation intact stability criteria, where the correspondence group agreed on the framework for the new generation intact stability criteria, which is based on the concept of intact stability failure and would be applicable to unconventional types of ships, assessed by vulnerability criteria, and also agreed that minimum requirements to ship-specific operational guidance should be developed. The correspondence group's report also contained the draft terminology for the new generation intact stability criteria.

4.9 In the context of the subject, the Sub-Committee also considered the following submissions by:

- .1 Japan (SLF 51/4/3), providing examples of the new generation intact stability criteria to cover three major phenomena, i.e., restoring variation problems such as parametric rolling; stability under dead ship condition; and manoeuvring-related problems such as broaching-to;
- .2 Germany (SLF 51/4/4 and SLF 51/INF.3), providing some interim results of the work on the development of procedures for direct assessment and onboard guidance, in which a particular type of partial stability failures, relating to possible cargo loss or damage for containerships due to large lateral accelerations (parametric and synchronous rolling), was presented, including further validation of numerical tools that can be used in the procedures for direct assessment and for the development of onboard guidance;
- .3 Poland (SLF 51/4/5), proposing to add a new criteria type "a holistic risk-based criterion" to the framework for the new generation intact stability criteria, contained in annex 2 to the report of the IS Correspondence Group (paragraph 1.3 Criteria Types);
- .4 the United States (SLF 51/INF.4), providing the abstract of a research document entitled "Toward Performance-Based Criteria for Intact Stability" concerning the development of performance-based intact stability criteria for ships; and
- .5 RINA (SLF 51/INF.6), providing the information on latest research outcomes for new generation intact stability criteria by the Japan Society of Naval Architects and Ocean Engineers (JASNAOE), which established a research committee for the IMO physics-oriented intact stability criteria and executed a systematic research programme covering three major phenomena,

and agreed to refer the above documents to the working group for further consideration.

### **EARLY IMPLEMENTATION OF THE 2008 IS CODE**

4.10 The Sub-Committee, having recalled that SLF 50 had decided to draft an MSC circular on early implementation of the 2008 IS Code at this session, discussed the matter and instructed the working group to prepare a draft MSC circular for consideration by the Sub-Committee, with a view to its submission to MSC 85 for approval.

### **Review of action plan for intact stability work**

4.11 The Sub-Committee instructed the working group to update the plan of action for intact stability work (SLF 50/WP.2, annex 6), as appropriate, taking into account the progress made at the session, and to consider the modification of the title of the item, in order to reflect the current work of the Sub-Committee.

### **ESTABLISHMENT OF THE WORKING GROUP**

4.12 The Sub-Committee established the Working Group on Intact Stability, and instructed it, taking into account comments made and decisions taken in plenary, to:

- .1 further consider the matter related to ships with large B/D ratio and weather criteria, taking into account documents SLF 51/4/1, SLF 51/4/2 and SLF 51/INF.2, and advise the Sub-Committee accordingly;
- .2 further consider the new generation intact stability criteria and complete items 2.1 and 2.2 in annex 6 to document SLF 50/WP.2 on the basis of documents SLF 51/4 and SLF 51/4/1, taking into account documents SLF 51/4/3, SLF 51/4/4, SLF 51/4/5, SLF 51/INF.3, SLF 51/INF.4 and SLF 51/INF.6;
- .3 prepare the draft MSC circular on Early implementation of the 2008 IS Code;
- .4 update the plan of action for intact stability work, contained in annex 6 to document SLF 50/WP.2, taking into account the progress made during the session;
- .5 consider the modification of the title of the item;
- .6 consider whether it is necessary to establish a correspondence group and, if so, prepare draft terms of reference for consideration by the Sub-Committee; and
- .7 submit a written report (part 1) to plenary for consideration and continue working through the week and submit part 2 of the report to SLF 52, as soon as possible after the session so that it can be taken into account by the correspondence group, if established.

### **REPORT OF THE WORKING GROUP**

4.13 Having received the report of the working group (part 1) (SLF 51/WP.2), the Sub-Committee approved it in general and took action as indicated in paragraphs hereunder, noting that part 2 of the group's report will be submitted by the Chairman of the group to SLF 52 as soon as possible after the session.

### **Ships with large B/D ratio**

4.14 In considering the outcome of the group on the matter related to ships with large B/D ratio, as contained in documents SLF 51/4/1 (paragraphs 4 and 5) and SLF 51/4/2, taking into account that the conclusions of the in-depth study conducted by the United Kingdom, comparing the effects of the different intact stability curve features on the critical roll index, supports the choice made at SLF 50 for this ship typology, the Sub-Committee noted that vessels with these characteristics have been sufficiently covered by the provisions contained in the draft Explanatory Notes to the International Code on Intact Stability, 2008 (2008 IS Code) (SLF 50/19, annex 5), which are expected to be formally approved at MSC 85 simultaneously with the adoption of the 2008 IS Code.

## **Weather criteria**

### ***Experience on the reduction of the pressure P to be used in the application of the weather criterion***

4.15 The Sub-Committee noted the deliberations of the group on the tests reported by the delegation of the United Kingdom (SLF 51/4/2), showing that reduction of the pressure P in the severe wind criterion seldom produces a proper result if the sea state, hence the roll back angle, is unchanged. The ships which have difficulty satisfying this criterion are frequently those with “early peaking” GZ curves. The difficulty may, therefore, be compounded by using a roll back angle derived from dynamic seaway response, in comparison of roll energies assuming a still water GZ curve.

4.16 The Sub-Committee also noted the group’s discussion concerning the contribution from the delegation of Japan providing a procedure (SLF 51/4/1, annex 1) to reduce the pressure P for ships engaged in restricted services. In the Japanese criteria, the ships are classified into three categories based on their navigational area, and for each category, a standard wind velocity and respective wind pressure are assigned and the wave steepness is calculated.

4.17 In considering the matters described in paragraphs 4.15 and 4.16 above, the Sub-Committee noted the group’s observation that in both reported procedures the reduction of pressure P is accompanied by reduction in wave steepness, which is also consistent with physics, however, it recalled the decision taken at SLF 48, as endorsed by MSC 81, that the weather criterion should be kept standard until new criteria are agreed upon.

### ***Evaluation of the roll prediction method in the weather criterion***

4.18 The Sub-Committee noted the group’s deliberations regarding a submission from the United Kingdom (SLF 51/INF.2), containing a detailed evaluation of the roll prediction method of the weather criterion, which showed that the majority of the United Kingdom fleet has B/D ratios greater than the range addressed by the weather criterion. The results show a significant discrepancy with respect to the maximum roll amplitudes predicted that is in line with previous results presented by Italy and Japan reported in the aforementioned document.

4.19 In light of the above, the delegation of the United Kingdom expressed the opinion that these results demonstrate that there is too great a level of uncertainty for the weather criterion to be included in a mandatory Code. However, the Sub-Committee recalled the decision taken at SLF 48, as endorsed by MSC 81, that the weather criterion should be kept as standard until new criteria are agreed upon, and invited the United Kingdom to further consider the matter under the future development of new generation intact stability criteria.

## **New generation intact stability criteria**

4.20 In considering the outcome of the group related to the new generation intact stability criteria on the basis of documents SLF 51/4 and SLF 51/4/1, taking into account documents SLF 51/4/3, SLF 51/4/4, SLF 51/4/5, SLF 51/INF.3, SLF 51/INF.4 and SLF 51/INF.6, the Sub-Committee agreed, in principle, to the Framework for the new generation intact stability criteria and the draft Terminology for the new generation intact stability criteria prepared by the group, as set out in annexes 1 and 2 to document SLF 51/WP.2, respectively, which will be kept as working documents for the development of the new generation intact stability criteria, and subject to further revision as needed.

4.21 In order to progress the work on the new generation intact stability criteria after this session, the Sub-Committee agreed that a significant work should be done intersessionally, as follows:

- .1 to identify a sample of ships relevant to the failure modes described in paragraph 2.2 of the Framework for the new generation intact stability criteria (SLF 51/WP.2, annex 1) for which the results of well documented experiments are available;
- .2 to collect and make available to members of the correspondence group all the relevant data of the ships (identified in subparagraph .1 above). The data should possibly include body lines and general arrangement plans, loading and operational conditions, appendages and, when required, propulsion and manoeuvring data, and experimental data;
- .3 to collect in the mid-term (tentatively March 2009) the results submitted by Member Governments and international organizations, concerning the application of procedures for checking vulnerability in accordance with paragraph 2.3 of the Updated plan of action, set out in annex 4 to document SLF 51/WP.2;
- .4 to collect in the mid-term (tentatively June 2009) the results submitted by Member Governments and international organizations, concerning the application of procedures for direct assessment of intact stability in accordance with paragraph 2.4 of the Updated plan of action, set out in annex 4 to document SLF 51/WP.2; and
- .5 on the basis of these results, coordinate the development of preliminary specifications for the quality of the procedures and for the quantities considered relevant for the formulation of new generation intact stability criteria.

4.22 Notwithstanding the above, the Sub-Committee agreed to invite Member Governments and international organizations to take part in this activity, by making available relevant data as per paragraph 4.21.1 above and submitting the results of the application of the procedures for vulnerability checking and direct assessment to the coordinator of the correspondence group.

4.23 The Sub-Committee, having noted that the work being undertaken by the International Towing Tank Conference (ITTC) is closely related to the tasks necessary to progress the work on this item intersessionally (see paragraph 4.21 above), agreed that ITTC should be invited to co-operate with the correspondence group on the aforementioned tasks by allowing the use of their collected data and knowledge and, consequently, requested the Secretariat to communicate with ITTC accordingly.

#### **Early implementation of the 2008 IS Code**

4.24 In considering the possible need for the application of the provisions of the 2008 IS Code by Contracting Governments to the 1974 SOLAS Convention and Parties to the 1988 LL Protocol before the Code has become effective, the Sub-Committee agreed to the draft MSC circular on Early application of the International Code on Intact Stability, 2008, set out in annex 4, for submission to MSC 85 for approval.



### **Review of the plan of action**

4.25 The Sub-Committee agreed to the Updated plan of action for intact stability work, prepared by the group (SLF 51/WP.2, annex 4), taking into account that, in 2009, no session of the Sub-Committee is scheduled and, therefore, much of the work will be advanced by the correspondence group.

### **Modification of the title of the item**

4.26 In reviewing the plan of action and taking into consideration that the draft 2008 IS Code is expected to be adopted at MSC 85, the Sub-Committee agreed that the title of this item should be changed to “Development of new generation intact stability criteria”, as most appropriate to reflect the current Updated plan of action for this item.

### **Re-establishment of the correspondence group**

4.27 The Sub-Committee agreed to re-establish the Correspondence Group on Intact Stability, under the coordination of Japan<sup>\*</sup>, and instructed the group to:

- .1 continue to work on the items contained in the Updated plan of action for intact stability work, set out in annex 4 to document SLF 51/WP.2, taking into account documents SLF 51/4, SLF 51/4/1, SLF 51/4/2, SLF 51/4/3, SLF 51/4/4, SLF 51/4/5, SLF 51/INF.2, SLF 51/INF.3, SLF 51/INF.4 and SLF 51/INF.6 and relevant documents from previous sessions;
- .2 further consider the new generation intact stability criteria on the basis of document SLF 51/WP.2, taking into account documents SLF 51/4/3, SLF 51/4/4, SLF 51/4/5, SLF 51/INF.3, SLF 51/INF.4 and SLF 51/INF.6;
- .3 identify a sample of ships relevant to the failure modes described in paragraph 2.2 of the Framework for the new generation intact stability criteria (SLF 51/WP.2, annex 1), for which the results of well documented experiments are available;
- .4 collect and make available to the correspondence group all the relevant data of the ships (identified in subparagraph .3 above). The data should possibly include body lines and general arrangement plans, loading and operational conditions, appendages and, when required, propulsion and manoeuvring data, and experimental data;

---

\* **Coordinator:**  
Dr. Eng. Naoya Umeda  
Associate Professor  
Department of Naval Architecture and Ocean Engineering  
Osaka University  
2-1 Yamadaoka, Suita  
Osaka 565-0871  
Japan  
Tel: + 81 6 6879 7587  
Fax: + 81 6 6879 7594  
E-mail: [umeda@naoe.eng.osaka-u.ac.jp](mailto:umeda@naoe.eng.osaka-u.ac.jp)

- .5 collect in the mid-term (tentatively March 2009) the results that Member Governments and international organizations have submitted to the Organization concerning the application of procedures for checking vulnerability in accordance with paragraph 2.3 of the Updated plan of action for intact stability work (SLF 51/WP.2, annex 4);
- .6 collect in the mid-term (tentatively June 2009) the results that Member Governments and international organizations have submitted to the Organization concerning the application of procedures for direct assessment of intact stability in accordance with paragraph 2.4 of the Updated plan of action for intact stability work (SLF 51/WP.2, annex 4);
- .7 on the basis of these results, coordinate the development of preliminary specifications for the quality of the procedures and for the quantities considered relevant for the formulation of new generation intact stability criteria; and
- .8 submit a report to SLF 52.

## **5 SAFETY OF SMALL FISHING VESSELS**

### **General**

5.1 The Sub-Committee recalled that SLF 50 had agreed, in principle, to the modifications proposed by the working group to the text of the draft Safety recommendations for decked fishing vessels of less than 12 metres in length and undecked fishing vessels and requested the Secretariat to prepare a consolidated text of the draft Safety recommendations.

5.2 The Sub-Committee also recalled that SLF 50, having endorsed the working group's recommended time frame for finalization of this work, specifying, *inter alia*, 2010 as the date for submission of the final draft Safety recommendations to the Committee for approval, had referred relevant parts of the draft Safety recommendations to the COMSAR, DE, FP, NAV and STW Sub-Committees as well as the MSC/MEPC Working Group on Human Element.

5.3 The Sub-Committee further recalled that SLF 50 had re-established the Correspondence Group on Fishing Vessel Safety to examine the text of the draft Safety recommendations, taking into account the ILO Convention and Recommendation concerning work in the fishing sector, FAO-related work and any comments of other sub-committees and the Committee.

5.4 The Sub-Committee noted that MSC 83, endorsing a proposal by SLF 50, had agreed to expand the Sub-Committee's existing work programme item to enable it to develop practical guidelines to assist competent authorities in implementation of the Fishing Vessels Safety Code, the Voluntary Guidelines and the Safety recommendations.

5.5 The Sub-Committee also noted that MSC 84 had referred an environmental issue, raised at MEPC 57, to the Sub-Committee for consideration and advice.

5.6 The Sub-Committee further noted that MSC 84, having agreed to include a new item on "Development of an agreement on the implementation of the 1993 Torremolinos Protocol" in the Sub-Committee's work programme, had instructed SLF 51 to give a preliminary consideration to the item.

## **Draft Safety recommendations**

5.7 The Sub-Committee, noting the consolidated text of the draft Safety recommendations prepared by the Secretariat (SLF 51/5), incorporating the modifications agreed by SLF 50, considered documents SLF 51/5/2, SLF 51/5/4 and SLF 51/2/2 (Secretariat), reporting on the outcome of FP 52, DE 51, STW 39, COMSAR 12, NAV 54 and MSC 84 (Human element WG) on the draft Safety recommendations.

5.8 Having considered the report of the correspondence group (SLF 51/5/1) submitted by South Africa, which examined the draft text of the Safety recommendations, taking into account the ILO's Work in Fishing Convention, 2007, FAO-related work and comments of other sub-committees, the Sub-Committee approved the report in general and, in particular, confirming the timetable for the completion of work by 2010, endorsed the recommendations that, upon finalization of the draft texts by other sub-committees, the text of the draft Safety recommendations should be reviewed by the Secretariat, to ensure consistency in style and format.

5.9 In the course of the consideration of the report of the correspondence group, the Sub-Committee noted that there was no clear indications of changes in the draft Safety recommendations and agreed that, in the future, the modified draft document should clearly show the proposed modifications. Subsequently, the Sub-Committee referred the draft Safety recommendations to the working group for further development.

5.10 In this regard, the Sub-Committee, noting the progress of FAO's work on wooden and FRP vessel construction standards, requested FAO to submit the result regarding Annexes II and III to the Safety recommendations to the DE Sub-Committee after the completion of its research project.

## **Guidelines to assist competent authorities**

5.11 The Sub-Committee considered document SLF 51/5/3 (FAO), providing some ideas relating to the development of new guidelines to assist competent authorities in the implementation of Part B of the Fishing Vessels Safety Code, the Voluntary Guidelines and the Safety recommendations, and proposing elements to be included in the guidelines and time frame for the finalization of the guidelines. The Sub-Committee noted that, in relation to the development of guidelines on best practices for safety at sea and the International Plan of Action (IPOA) on the matter, FAO would, later in 2008, convene an Expert Consultation, to which ILO and IMO will be invited to participate. Following discussion, the Sub-Committee referred the matter to the working group for development of an initial draft of new guidelines.

## **Outcome of MEPC 57 relating to impact of small craft on the marine environment**

5.12 The Sub-Committee considered document SLF 51/2/2 (Secretariat), informing that MEPC 57, having considered documents MEPC 57/20 (FOEI) and MEPC 57/INF.18 (United Kingdom) regarding the impact of small pleasure and fishing craft on the marine environment and possible action by IMO, had invited the Maritime Safety Committee to consider addressing the issue of reducing oil discharges in the work programme, and reporting the outcome of MSC 84 that it had agreed to refer those documents to the Sub-Committee and instructed it to consider the issue and advise the Committee as appropriate.

5.13 After discussion, the Sub-Committee referred the matter to the working group for further consideration, as appropriate.

### **Implementation of the 1993 Torremolinos Protocol**

5.14 The Sub-Committee noted the outcome of MSC 84 relating to the implementation of the 1993 Torremolinos Protocol (SLF 51/2/2), informing that MSC 84, having considered document MSC 84/22/21 (Iceland), proposing to prepare a draft Agreement on the implementation of the 1993 Torremolinos Protocol to facilitate and expedite the earliest possible entry into force of the Protocol, as called for under resolution A.1003(25), together with document MSC 84/22/16 (Secretariat), summarizing the outcome of Joint FAO/IMO *ad hoc* Working Group (JWG), MSC 83 and A 25, taking into account the conclusions of the 2004 Beijing Regional Seminar and the study conducted by an IMO consultant on the conditions for the entry into force of the Protocol, had agreed to include a new item on “Development of an agreement on the implementation of the 1993 Torremolinos Protocol” in the Sub-Committee’s work programme and instructed SLF 51 to give a preliminary consideration.

5.15 The Sub-Committee also noted document SLF 51/INF.7 (Secretariat), providing the outcome of the 2004 Beijing Regional Seminar for facilitating the consideration on the matter, containing the work carried out by the two working groups of the Beijing Seminar on technical and legal difficulties and a detailed list of recommendations concerning the follow-up actions to be undertaken by the Organization.

5.16 The Sub-Committee acknowledged the importance of considering various options, including the option for an agreement on implementation of the 1993 Torremolinos Protocol, and noted the explanation by the Secretariat that the acceptance of the Protocol by countries which have large fishing fleets is essential for giving effect to the Protocol and that the joint effort to overcome the difficulties of accepting the Protocol is also of utmost importance.

5.17 Subsequently, the Sub-Committee referred the matter to the working group for further consideration and, in particular, instructed it to identify technical regulations of the 1993 Torremolinos Protocol to be included in an agreement on the implementation of the 1993 Torremolinos Protocol, taking into account document SLF 51/INF.7, and advise the Sub-Committee as appropriate.

### **ILO’s Work in Fishing Convention and Recommendation**

5.18 The Sub-Committee noted the information (SLF 51/INF.5), together with brochures, provided by ILO on the Work in Fishing Convention, 2007 (No.188) and Work in Fishing Recommendation, 2007 (No.199), which are relevant to safety and health of fishers and to fishing vessel design and construction, including information on relations between length and gross tonnage and specific references to IMO instruments and publications, in particular to the 1969 TM Convention and the 1995 STCW-F Convention.

### **Establishment of the working group**

5.19 The Sub-Committee established the Working Group on Safety of Small Fishing Vessels and instructed it, taking into account comments made and decisions taken in plenary, to:

- .1 further examine the draft Safety recommendations for decked fishing vessels of less than 12 metres in length and undecked fishing vessels, based on documents SLF 51/5, SLF 51/5/1, SLF 51/5/2, SLF 51/5/4 and SLF 51/2/2;

- .2 develop an initial draft of new guidelines to assist competent authorities in the implementation of Part B of the Fishing Vessels Safety Code, the Voluntary Guidelines and the Safety recommendations, taking into account document SLF 51/5/3;
- .3 consider the matter relating to the impact of small pleasure and fishing craft on the marine environment and advise the Sub-Committee, as appropriate;
- .4 identify technical regulations of the 1993 Torremolinos Protocol to be included in an agreement on the implementation of the 1993 Torremolinos Protocol, taking into account document SLF 51/INF.7, with a view to finalizing the agreement at SLF 52; and
- .5 prepare draft terms of reference for the correspondence group.

### **Report of the working group**

5.20 Having received the report of the working group (SLF 51/WP.3), the Sub-Committee approved it in general and took action as indicated in paragraphs hereunder.

### ***Modifications to the draft Safety recommendations***

5.21 The Sub-Committee noted that the group had considered documents SLF 51/5, SLF 51/5/1, SLF 51/5/2 and SLF 51/5/4 as well as document SLF 51/2/2, taking into account the ILO Work in Fishing Convention, 2007 (No.188) and Recommendation, 2007 (No.199) in order to align the text of the draft Safety recommendations with, or make reference to, the Convention, and agreed, in principle, to the group's modifications to the draft Safety recommendations, as set out in annex 1 to document SLF 51/WP.3.

5.22 In agreeing to the above-mentioned modifications, the Sub-Committee noted that the correspondence group had continued its work after the deadline date for submission of documents to be considered at SLF 51 to allow for consideration of the reports of those sub-committees whose reports were received after the submission deadline and that some delegations were unable to participate in the above work. In this regard, the delegation of Panama expressed its dissatisfaction with the above method of work as its delegation was not able to consider the new information prepared by the correspondence group prior to the meeting.

### ***Time frame for completion of the draft Safety recommendations***

5.23 Since relevant parts of the present draft Safety recommendations will be referred to other sub-committees for their consideration, the Sub-Committee agreed that the finalization of the work should be accomplished based on the following time frame:

- .1 2008/2009: other sub-committees finalize assigned work on the relevant chapters and annexes of the draft Safety recommendations; and
- .2 2010: the Sub-Committee submits the final draft of the Safety recommendations to the Committee for approval.

### ***Guidelines to assist competent authorities***

5.24 The Sub-Committee noted that the group had considered document SLF 51/5/3 and the comments made in plenary, in order to establish a suitable framework for the development of the guidelines to assist competent authorities in the implementation of Part B of the Fishing Vessel Safety Code, the Voluntary Guidelines and the Safety Recommendations. In this regard, the Sub-Committee noted the group's view that the existing "MARPOL-how to do it" publication provides a useful format for the development of these guidelines and, to make progress, prepared a preliminary list of contents for the guidelines (SLF 51/WP.3, annex 2). However, due to the limited time available for the group to deal with the task, the Sub-Committee agreed that the correspondence group should continue development of the aforementioned draft guidelines.

5.25 In this regard, the Sub-Committee noted the group's view that, given the number of publications that relate to fishing vessel safety and the cost to Administrations, consideration should be given to providing the above guidelines, once finalized, in all official languages of the Organization, at the lowest possible cost (e.g., web download).

### ***Impact of small pleasure and fishing craft on the marine environment***

5.26 Recalling the comments made in plenary and the instruction by MSC 84 on addressing the possible action by IMO on the impact of small pleasure and fishing craft on the marine environment, the Sub-Committee noted the group's concern that it had minimal expertise in environmental matters and, therefore, it could not properly address these issues. Consequently, the Sub-Committee agreed that relevant environmental issues should be addressed by the MEPC, in consultation with other UN agencies and non-governmental organizations, and invited MEPC 58 to consider the above view and take action as appropriate.

### ***Development of an Agreement on the implementation of the 1993 Torremolinos Protocol***

5.27 The Sub-Committee noted that the group had considered in-depth documents SLF 51/INF.7 and SLF 51/2/2 and the comments made in plenary in order to recommend the most effective procedure to prepare a draft Agreement on the implementation of the 1993 Torremolinos Protocol. In discussing how best to proceed, the Sub-Committee agreed that the Secretariat should initiate a consultation process with States that have more than 500 registered fishing vessels of 24 metres in length and over, on the basis of the information provided in document C 93/4/Add.2, annex 7, table 2.

5.28 In this regard, the Sub-Committee agreed that the above consultation process should initially be in the form of a questionnaire and endorsed, in principle, the questionnaire contained in annex 3 to document SLF 51/WP.3. Subsequently, the Sub-Committee agreed that the information gathered from the questionnaire should be provided to the correspondence group to assist it with drafting the Agreement and the technical amendments to facilitate the widespread ratification of the 1993 Torremolinos Protocol and its entry into force.

5.29 In considering the timing for the development, implementation and conclusion for this task, the Sub-Committee agreed to the Roadmap towards entry into force of the 1993 Torremolinos Protocol, set out in annex 5, and urged Member States that have had difficulty in ratifying the Protocol and Member States that have already ratified it to participate in the correspondence group at both a technical and policy level.

5.30 The Committee was invited to endorse the above course of action.

***Re-establishment of the correspondence group***

5.31 The Sub-Committee, taking into account the ongoing work and the two new tasks that have been assigned, re-established the correspondence group, under the coordination of South Africa\*, and instructed it to:

- .1 further develop the draft Safety recommendations for decked fishing vessels of less than 12 metres in length and undecked fishing vessels, taking into consideration the outcomes of FP 53, DE 52 and SLF 51, and prepare a consolidated text thereof as appropriate;
- .2 prepare a draft Agreement on the implementation of the 1993 Torremolinos Protocol;
- .3 further develop the draft guidelines to assist competent authorities in the implementation of Part B of the Fishing Vessel Safety Code, the Voluntary Guidelines and the Safety Recommendations and consider the title; and
- .4 submit a report to SLF 52.

**6 DEVELOPMENT OF OPTIONS TO IMPROVE EFFECT ON SHIP DESIGN AND SAFETY OF THE 1969 TM CONVENTION**

**General**

6.1 The Sub-Committee recalled that SLF 50 had established a correspondence group and instructed it to develop “maritime real estate” (SLF 50/6/1) and other options to improve effect on ship design and safety of the 1969 TM Convention; to identify pros and cons of those options; and to consider the merits of amending the Convention to incorporate tacit acceptance procedure for amendments or, alternatively, adopting a protocol to the Convention, with a view to facilitating future amendments.

6.2 The Sub-Committee had for its consideration:

- .1 document SLF 51/6 (Australia), reporting on the outcome of the correspondence group, namely that the group considered 6 options (“maritime real estate” concept; promotion of the use of net tonnage, allowing semi-open spaces to be excluded from total enclosed volume; revision of the net tonnage parameter to include a deck cargo allowance; a third tonnage parameter Gross Tonnage Maximum Capacity (GT<sub>MaxCap</sub>) that includes deck cargo volume; and “nil action” option) to

---

\* **Co-ordinator:**

Captain Nigel T. Campbell  
South African Maritime Safety Authority  
P.O. Box 3914  
North End, Port Elizabeth, 6065, South Africa  
Tel: +27 (0)41 585 0051  
Fax: +27 (0)41 582 1213  
E-mail: [ncampbell@samsa.org.za](mailto:ncampbell@samsa.org.za)  
CG website: [www.sigling.is/FVS-ISCG](http://www.sigling.is/FVS-ISCG)

improve the effect on ship design and safety of the 1969 TM Convention, identifying pros and cons of those options, and concluding that any action by IMO, whether through or in parallel with the TM Convention, should be thoroughly evaluated as to its effects on ship design and the shipping industry. It was reported that the group also considered the merits of amending the Convention to incorporate tacit acceptance procedure for amendments and was of the view that it would be advisable for the Convention to be amended at the earliest opportunity by insertion of the tacit acceptance procedure for amendments; and

- .2 document SLF 51/6/1 (Germany), providing comments on the options addressed by the report of the correspondence group, in particular that Germany considers that the biggest advantage of the current TM Convention is its simplicity and transparency, and is reluctant to give the advantages of the current regime away, without explicitly understanding the added value of the proposed safety incentives.

6.3 Having considered the action requested of the Sub-Committee, as contained in the report of the correspondence group (SLF 51/6), and taking into account document SLF 51/6/1, the Sub-Committee, after extensive discussion, established a drafting group and instructed it, taking into account the comments made and decisions taken in plenary, to:

- .1 prepare text outlining the outcome of the Sub-Committee's consideration of options to improve the effect on ship design and safety of the 1969 TM Convention, based on document SLF 51/6 and taking into account document SLF 51/6/1, for reporting to MSC 85;
- .2 prepare justification for amending the 1969 TM Convention to include tacit acceptance procedure for amendments, with a view to endorsement by MSC 85; and
- .3 prepare terms of reference for a correspondence group to work on the existing work programme item, if extended by MSC 85.

### **Report of the drafting group**

6.4 Having considered the report of the drafting group (SLF 51/WP.6), the Sub-Committee agreed to the outcome of the Sub-Committee's deliberations on the item, prepared by the group, as indicated in paragraphs hereunder.

### **Consideration of the options for improving the 1969 TM Convention**

6.5 The Sub-Committee noted the following general comments made during the debate:

- .1 a considerable body of work had been provided in documents SLF 51/6 (Australia) and SLF 51/6/1 (Germany) which still needs in-depth technical evaluation and that the options proposed are not exhaustive and subsequent options, if raised, should also be given due consideration;
- .2 the issues to be discussed during necessary further evaluation of the options should be undertaken in a holistic manner with regard to safety issues, the economic impact on the maritime industry and human factors;



- .3 some types of ships may be adversely affected by the incentive to reduce freeboard at the possible expense of enhanced safety;
- .4 it might be possible to implement some of the proposed options without requiring a change to the Convention;
- .5 some options will require amendments to the Convention in order to be implemented and, therefore, consideration should be given to developing tacit acceptance procedure for amendments to allow for greater flexibility to respond to the needs of industry;
- .6 it would be preferable to develop tacit acceptance procedure for amendments provisions first and then finalize the in-depth technical evaluation of the options for incorporation at a later date; and
- .7 that frequent revisions to the Convention, resulting from the greater flexibility afforded by the tacit acceptance procedure for amendments, may have a detrimental effect with regard to its consistent application.

6.6 Having considered the above comments, the Sub-Committee agreed that, in order to remove the aforementioned disincentives for improved safety and provide greater flexibility to incorporate future amendments, a way for adoption of amendments via tacit acceptance procedure should be developed as an immediate first step, taking into account concerns mentioned in paragraph 6.5.7 above.

6.7 In addition, the Sub-Committee agreed that an in-depth technical evaluation of the proposed options referred to in paragraph 6.5.1 should be undertaken in parallel, taking into account any further options that may be proposed.

### **Options for amending the 1969 TM Convention**

6.8 The Sub-Committee, in considering the options for amending the 1969 TM Convention, recalled that during development of this work it became evident that implementation of options requiring amendments to the 1969 TM Convention, or any future amendments to that Convention, was difficult, because of the lack of an efficient mechanism in the 1969 TM Convention for amending it and that it was desirable to introduce such a mechanism.

6.9 The Sub-Committee also noted that amendments to the 1969 TM Convention would facilitate resolution of the difficulties posed in applying the Convention in a uniform and transparent manner to ship types that were not prevalent when the Convention was adopted and might obviate the need for a large number of uniform interpretations, disseminated by means of TM circulars. This problem is applicable to many ship types, including:

- .1 open-top containerships;
- .2 offshore supply vessels;
- .3 ro-ro vessels, especially car carriers;
- .4 submersible heavy lift vessels; or
- .5 the many novel types developed since the enforcement of the Convention.

6.10 Subsequently, the Sub-Committee discussed three options to incorporate the tacit acceptance procedure for amendments into the 1969 TM Convention, as follows:

- .1 adoption of a Protocol to the Convention, which would require the convening of a diplomatic conference;
- .2 using the existing unanimous acceptance provision specified in Article 18(2) of the Convention; and
- .3 using the explicit acceptance procedure specified in Articles 18(3) and 18(4).

6.11 In considering the merits of the above options, the Sub-Committee noted the following:

- .1 with regard to option .1, implementation of a Protocol to the Convention would be quicker than the other options, however, two regimes would exist, with differing Parties to the Convention and the Protocol, and there are budgetary considerations associated with its facilitation;
- .2 with regard to option .2, it would only take three years for the amendments to enter into force if this option is used, and there are no associated budgetary considerations, however, it is dependent upon there being no objections; and
- .3 with regard to option .3, it would require acceptance of the amendments by 2/3 of the Contracting Governments to the Convention if this option is used and, therefore, it may take many years before this condition is met.

#### **Extension of the target completion date**

6.12 The Sub-Committee, in view of the above developments, invited MSC 85 to extend the target completion of the existing work programme item to 2011, taking into account discussions of possible amendments options outlined in paragraph 6.10.

#### **Re-establishment of the correspondence group and its terms of reference**

6.13 The Sub-Committee agreed to re-establish the Correspondence Group on Development of options to improve effect on ship design and safety of the 1969 TM Convention, under the coordination of Australia and the Netherlands\*, to carry out the work, if extension of the work programme item was endorsed by MSC 85, and instructed the group, taking into account the potential effects on safety, ship design, human factors, economic and other operational considerations, to:

---

\* **Coordinators:**

Mr. Guy Anderson  
Senior Adviser – Technical Regulation  
Ship Safety  
Maritime Standards Division  
Australian Maritime Safety Authority  
Level 1, 25 Constitution Avenue  
Canberra ACT 2601  
AUSTRALIA  
Tel: + 61 2 6279 5651  
Fax: + 61 2 6279 5966  
Email: [guy.anderson@amsa.gov.au](mailto:guy.anderson@amsa.gov.au)

Mr. K. Metselaar, Msc.  
Senior Policy Advisor  
Ministry of Transport, Public Works and Water  
Management  
Maritime Transport Department  
Plesmanweg 1-6  
P.O. Box 20904  
2500 EX The Hague  
THE NETHERLANDS  
Tel: +31 70 351 1519  
Fax: +31 70 351 1692  
Email: [kees.metselaar@minvenw.wl](mailto:kees.metselaar@minvenw.wl)

- .1 further develop and evaluate the options in document SLF 51/6, taking into account document SLF 51/6/1 and relevant documents from previous sessions;
- .2 further develop and evaluate subsequent options which may be identified during this work;
- .3 identify the added value of the options, as appropriate;
- .4 further investigate the options for amendments to the 1969 TM Convention;
- .5 make recommendations, as appropriate; and
- .6 submit a report to SLF 52.

## **7 GUIDELINES FOR UNIFORM OPERATING LIMITATIONS ON HIGH-SPEED CRAFT**

7.1 The Sub-Committee recalled that SLF 50, having noted general support to the information in document SLF 50/INF.4 (United Kingdom), had agreed that the guidelines should be primarily for Administrations, taking into account sea-keeping, stability and measurement of wave heights for operational matters.

7.2 The Sub-Committee also recalled that SLF 50, noting that DE 50 established a correspondence group on the matter, had invited Member Governments and international organizations to contribute to the correspondence group and to submit their proposals and comments to SLF 51.

7.3 The Sub-Committee considered document SLF 51/7 (Secretariat), reporting on the outcome of DE 51 that it, having considered the report of the correspondence group submitted by Australia (DE 51/13), attaching draft Guidelines for uniform operating limitations of high-speed craft, had supported the draft Guidelines prepared by the correspondence group in principle.

7.4 In this regard, the Sub-Committee noted that DE 51, having agreed that further work was necessary, in particular concerning a consistent application of operating limits for different wave heights and sea trials at lower wave heights and subsequent extrapolation of wave heights, had re-established the correspondence group to finalize the draft Guidelines, incorporating the contributions provided by COMSAR 12, SLF 51 and NAV 54.

7.5 The Sub-Committee also noted the developments within the correspondence group established by DE 51, pertaining to this Sub-Committee, as follows:

- .1 consideration was given to accepting the use of instrumentation for measurement of vertical accelerations in place of speed/wave height restrictions for monitoring structural loads;
- .2 extrapolation of sea-keeping performance was vigorously debated within the group;
- .3 discussion on measurement of wave height was minimal;
- .4 guidance for operation in following and stern quartering seas, as proposed by the United Kingdom, was inserted as an appendix; and

- .5 final decision yet to be made on whether or not to insert an appendix on wake wash waves risk assessment.

7.6 Following brief discussion, the Sub-Committee, having noted that the draft Guidelines would be finalized at DE 52, invited Members and international organizations to contribute to the correspondence group established by DE 51. The Secretariat was requested to inform the DE Sub-Committee accordingly.

### **Completion of the item**

7.7 The Sub-Committee considered that the work on the item had been completed and invited the Committee to delete the item from the Sub-Committee's work programme.

## **8 TIME-DEPENDENT SURVIVABILITY OF PASSENGER SHIPS IN DAMAGED CONDITION**

8.1 The Sub-Committee recalled that SLF 50 had noted document SLF 50/8 (ITTC), providing the first stage of the ITTC time-to-flood benchmarking study which concluded that, for ships having a relatively simple internal geometry in calm water, reasonable time-to-sink predictions appeared feasible, and invited the ITTC to provide updated information on this matter.

8.2 The Sub-Committee considered document SLF 51/8 (ITTC), providing a preliminary report on the second stage of the benchmark testing of numerical codes for time-to-flood prediction for damaged passenger ships for realistic cruise ship data with only two numerical results based on two codes, and concluding that, for the most severe flooding and sea conditions, considerable differences appeared for the predicted time-to-flood between the benchmarked two codes and that the true performance of all today available codes, however, can only be evaluated when accurate experimental model benchmark data are available for comparison and a wider participation is achieved.

8.3 Recognizing the need for more information, the Sub-Committee invited Member Governments and international organizations to submit their proposals and comments on the item to the next session.

### **Extension of the target completion date**

8.4 Since the target completion date of this item is 2009 and there is no meeting in 2009, the Sub-Committee invited the Committee to extend the target completion date of the item to 2011.

## **9 CONSIDERATION OF IACS UNIFIED INTERPRETATIONS**

9.1 The Sub-Committee recalled that this was a continuous item on its work programme, established by MSC 78 so that IACS could submit any newly developed or updated unified interpretations (UI) for the consideration of the Sub-Committee with a view to developing appropriate IMO interpretations.

9.2 The Sub-Committee had for its consideration the following documents submitted by IACS:

- .1 document SLF 51/9, providing the revised IACS UI LL 65 – “Ships with assigned or reassigned reduced freeboards and intended to carry deck cargo”, which will be applied by IACS members in accordance with its implementation date of 1 January 2009, and requesting the Sub-Committee to consider forwarding the UI to the SDS Working Group;

- .2 document SLF 51/9/1, providing the IACS UI SC 155, Rev.1 – “Lightweight check in lieu of inclining test”, which clarifies how IACS members approve lightship characteristics on behalf of Administrations, according to MSC/Circ.1158. The UI requires that, if the tolerances in MSC/Circ.1158 are exceeded, the Administration is to be contacted to determine the acceptability of such a deviation; and
- .3 document SLF 51/9/2, providing the IACS UI SC 161, Rev.1 – “Timber deck cargo in the context of damage stability requirements”, which clarifies how IACS members will approve stability information in accordance with SOLAS regulation II-1/5-1, for ships carrying timber deck cargoes where the buoyancy of the timber deck cargo is taken into account in the damage stability calculations.

9.3 Following the discussion, the Sub-Committee:

- .1 with regard to the UIs contained in documents SLF 51/9 and SLF 51/9/2, agreed to forward the aforementioned UIs to the SDS Working Group, established under agenda item 3, for consideration and advice (see paragraphs 9.4 to 9.6); and
- .2 with regard to UI SC 155 contained in document SLF 51/9/1, noted the UI, recognizing that the contents of the UI is covered by the revised SOLAS chapter II-1, which is due to enter into force on 1 January 2009.

9.4 Having considered the part of the report of the SDS Working Group (SLF 51/WP.1) relating to the item, the Sub-Committee took action as indicated in paragraphs 9.5 and 9.6.

9.5 The Sub-Committee noted that the group had considered IACS UI LL 65 – “Ships with assigned or reassigned reduced freeboards and intended to carry deck cargo” (SLF 51/9) and SC 161, Rev.1 – “Timber deck cargo in the context of damage stability requirements” (SLF 51/9/2) and had the following comments:

- .1 regarding UI LL 65, the scope of application of the UI should be made clearer, i.e. that it applies only to new ships built after 1 January 2009; and
- .2 regarding UI SC 161, the text in footnote No.2 referring to the application date should be clarified. In this connection, the group noted that MSC/Circ.998 (IACS Unified Interpretation regarding timber deck cargo in the context of damage stability requirements) should be reconsidered when the clarification from IACS has been received.

9.6 Consequently, the Sub-Committee invited IACS to provide the clarification requested above to the next session of the Sub-Committee for consideration. During the consideration of the working group’s report, IACS pointed out that, technically, there is no disagreement with the IACS Unified Interpretations submitted in documents SLF 51/9 and SLF 51/9/2, and that, therefore, MSC circulars on unified interpretations should be drafted with the application dates suitably amended by the Sub-Committee. IACS expressed disappointment that there would now be a delay of 18 months to the next Sub-Committee meeting, and that MSC circulars would not be approved until 2010.

## **10 GUIDANCE ON THE IMPACT OF OPEN WATERTIGHT DOORS ON EXISTING AND NEW SHIP SURVIVABILITY**

10.1 The Sub-Committee recalled that SLF 50, having considered document SLF 50/15 (Sweden and United States), proposing the draft guidance, and document SLF 50/15/1 (CLIA), expressing that the proposed guidance remained exceedingly deterministic/strict especially for existing ships and may not be appropriate for new ships, had noted mixed views on the proposed guidance and invited Member Governments and international organizations to submit their proposals and comments to this session, with a view to finalizing the guidance.

10.2 The Sub-Committee considered the following documents:

- .1 document SLF 51/10 (Germany), providing the German view that the guidance to be developed should distinguish between existing and new ships and that, for new ships, it is possible to incorporate the requirements by design at an early stage, while for existing ships there remains not much but operational procedures;
- .2 document SLF 51/10/1 (Sweden and United States), proposing updated version of the previously proposed guidance by which Administrations may determine the impact of open watertight doors on survivability, modifying the stability criteria associated with the “floatability” assessment in the proposed guidance to align with the intermediate stage flooding criteria in the new harmonized SOLAS chapter II-1, regulation 7-2.2, which should be applicable to both existing and new ships; and
- .3 document SLF 51/10/3 (CLIA), wherein CLIA expressed the opinion that the work of the DE Sub-Committee with regard to operational limitations of watertight doors should be concluded before any consideration can be given to survivability or floatability requirements.

10.3 The Sub-Committee noted document SLF 51/10/2 (Secretariat), reporting that DE 51, having considered document DE 51/26/2, stating that there is a need for restrictive application of the possibility to permit watertight doors to remain open during navigation, and that guidance is needed regarding operational provisions but also concerning the technical standard of watertight doors, had supported the proposals as a good starting point. In the context of this item, the Sub-Committee, also noting that, while the Sub-Committee would consider the survivability implications of the proposal, the DE Sub-Committee should deal with operational issues, had agreed to establish a correspondence group and instructed it to develop the draft guidance for Administrations (see paragraph 10.6).

10.4 During the extensive discussion, the Sub-Committee noted:

- .1 that the majority of delegations strongly supported the Germany’s view that the guidance to be developed should distinguish between existing and new ships (SLF 51/10, paragraph 10);
- .2 views of delegations, stressing the importance of taking into account operational and training aspects, in supporting CLIA’s opinion;
- .3 views of delegations, emphasizing the risks associated with having open watertight doors while at sea, including related accidents; and

- .4 IACS's advice that its unified interpretation SC156 would be useful for the Sub-Committee's deliberation.

10.5 Subsequently, the Sub-Committee agreed that, while the DE Sub-Committee should develop operational guidance, this Sub-Committee should develop design and construction guidance from the survivability point of view, distinguishing between new and existing ships, on the basis of the draft guidance set out in the annex to document SLF 51/10/1, taking into account the above IACS's Unified Interpretation. In this regard, the Sub-Committee noted the statement by the delegations of Sweden and the United States, set out in annex 8, which was supported by the delegation of Italy.

10.6 In view of the above decision, the Sub-Committee instructed the SDS Correspondence Group established under agenda item 3 (see paragraph 3.26), taking into account:

- .1 the draft text contained in document SLF 51/10/1 together with comments and proposals submitted in documents SLF 51/10 and SLF 51/10/3;
- .2 IACS UI SC 156 dated June 2006;
- .3 applicability of any formulae; and
- .4 the need to differentiate between new and existing ships for applicability of the guidance,

to prepare a draft Guidance on the impact of open watertight doors on existing and new ship survivability, and to submit a report to SLF 52.

10.7 The Sub-Committee requested the Secretariat to inform the DE Sub-Committee of the outcome on the item and invited DE 52 to take into account the draft Guidance to be developed by the SDS Correspondence Group when considering the matter.

#### **Extension of the target completion date**

10.8 In view of the above developments, the Sub-Committee invited the Committee to extend the target completion date of the item to 2010.

### **11 STABILITY AND SEA-KEEPING CHARACTERISTICS OF DAMAGED PASSENGER SHIPS IN A SEAWAY WHEN RETURNING TO PORT BY OWN POWER OR UNDER TOW**

11.1 The Sub-Committee recalled that MSC 82 had included a new item on "Stability and sea-keeping characteristics of damaged passenger ships in a seaway when returning to port by own power or under tow" in the Sub-Committee's work programme and requested SLF 50 to give a preliminary consideration to the matter.

11.2 The Sub-Committee also recalled that SLF 50, following consideration of document SLF 50/8/1 (United Kingdom) and an extensive debate on how best to proceed on this issue, had established a correspondence group to make progress on the matter intersessionally.

11.3 The Sub-Committee considered the report of the correspondence group (SLF 51/11) submitted by the United Kingdom, providing the outcome of the group's consideration regarding the development of design and damage stability criteria for passenger ships for safe return to port by own power or under tow and the development of guidelines for operational information for masters of passenger ships to enable a safe return to port following damage, and the following related submissions:

- .1 document SLF 51/11/1 (Italy, Spain and CESA), informing the Sub-Committee of the results of an investigation into the casualty threshold methodology introduced by Lloyd's Register and based on data provided by European yards for a range of SOLAS 2009 compliant designs, wherein the data provided details on various ranges of criteria from  $s=1$  to a level comparable with intact stability requirements on a selection of passenger ships. It was observed that, based on the agreed casualty threshold of one-compartment flooding indicated by SOLAS regulation II-1/8-1, the overall achievable index for safe return to port would be in the region of 0.3;
- .2 document SLF 51/11/2 (Germany), providing some additional comments on issues addressed by the report of the correspondence group. In particular, Germany was of the opinion that the required index should be related to the necessary or preferred level of safety intended for the design capability for safe return to port of passenger ships, and that onboard stability computers would need to be approved by the competent Administration or on its behalf;
- .3 document SLF 51/11/3 (United States), supporting views that the SLF Sub-Committee's task to amend SOLAS regulation 8-1 should be modified "to prescribe a set of minimum stability criteria that will enable a passenger ship to return to port and to use it for operational information only, i.e. no design requirement", and providing a possible option for a SOLAS regulation II-1/8-1 amendment, which added a simple provision to regulation 8-1 regarding operational guidance for safe return to port, with the details to be provided in guidelines to be developed by the Organization; and
- .4 document SLF 51/11/4 (Japan), wherein Japan, after examining the current situation of the safety level of damaged passenger ships in still water through the comparison with the criteria in regulation II-1/7 of SOLAS 2009 and in the Intact Stability Code (IS Code), which is one of existing criteria for ensuring the stability in winds and waves, informed that both a damaged large passenger ship and a damaged ro-ro passenger ferry, assuming minor damage, are hard to comply with requirements of the IS Code owing to the progressive flooding and the insufficiency of GZ range, and proposed the methodology for determining the operational guidance for safe return to port.

11.4 In the course of consideration of the above documents, the Sub-Committee noted that a majority of delegations who spoke supported the United States' view that only operational guidance should be developed for safe return to port, which should also address the need for onboard computers, and decided to refer the matter to the SDS Correspondence Group established under agenda item 3, taking into account the documents submitted to this session (see paragraph 3.26).



11.5 Following discussion, the Sub-Committee instructed the aforementioned SDS Correspondence Group, taking into account the comments made and decisions taken in plenary, to:

- .1 develop design and damage stability criteria for passenger ships for safe return to port by own power or under tow;
- .2 prepare draft guidelines for operational information for masters of passenger ships for safe return to port by own power or under tow;
- .3 prepare draft amendments to SOLAS regulation II-1/8-1; and
- .4 submit a report to SLF 52.

#### **Extension of the target completion date**

11.6 In view of the above development, the Sub-Committee invited the Committee to extend the target completion date of the item to 2011.

## **12 GUIDELINES FOR DRAINAGE SYSTEMS IN CLOSED VEHICLE AND RO-RO SPACES AND SPECIAL CATEGORY SPACES**

12.1 The Sub-Committee recalled that MSC 83, having considered submission by Denmark, Norway and Sweden (MSC 83/3/2), proposing amendments to SOLAS chapter II-1 to establish provisions concerning the drainage of fire-fighting water in enclosed ro-ro spaces, together with the proposal by Egypt (MSC 83/25/2) to improve fire-fighting water drainage capacity on the vehicle deck of ro-ro ships, had included, in the Sub-Committee's work programme and the provisional agenda for SLF 51, the high-priority item on "Guidelines for drainage systems in closed vehicle and ro-ro spaces and special category spaces", with a target completion date of 2009, assigning the FP Sub-Committee as coordinator.

12.2 The Sub-Committee noted document SLF 51/12 (Secretariat), informing that MSC 83 approved the draft amendments to SOLAS chapters II-1 and II-2, and also noted that, in the context of the item, MSC 84 had adopted the amendments to SOLAS regulation II-2/20 (Protection of vehicle, special category and ro-ro spaces), referring to the Guidelines for drainage systems in closed vehicle and ro-ro spaces and special category spaces to be developed. In this regard, the Sub-Committee further noted that FP 52 had instructed the Correspondence Group on Performance Testing and Approval Standards for Fire Safety Systems to further develop the Guidelines with a view to finalization at FP 53.

12.3 In the course of discussion, the Sub-Committee considered the specifications for the drainage capacity and the "scupper grating" construction, as proposed in document MSC 83/3/2, and, having noted that the related specification was developed by the SDS Working Group (SLF 49/WP.1), agreed to the specifications as follows:

"The drainage from enclosed ro-ro spaces or special category spaces should be of such capacity that two-thirds of the scuppers, freeing ports, etc., on the starboard or port side are capable of draining off a quantity of water originating from both sprinkler pumps and fire pumps, taking into account a list of 1° for ships with a breadth of 20 m or more and 2° for ships with a breadth below 20 m and a trim forward or aft of 0.5°.

Scuppers on ro-ro decks should be provided, over the outlet grate, with a removable grill with vertical bars, to prevent large obstacles from blocking the drain. The grill may be placed obliquely against the side of the ship. The grill should have a height of at least 1 m above the deck and should have a free flow area of at least 0.4 m<sup>2</sup>, while the distance between the individual bars should be not more than 25 mm.”

12.4 Furthermore, having recognized that there is no meeting in 2009 and the aforementioned amendments to SOLAS regulation II-2/20 are expected to enter into force on 1 January 2010, the Sub-Committee invited Member Governments and international organizations to contribute to the correspondence group established by FP 52 on this issue and requested the Secretariat to inform FP 53 of the above outcome.

### **Completion of the item**

12.5 The Sub-Committee considered that the work on the item had been completed and invited the Committee to delete the item from the Sub-Committee’s work programme.

## **13 GUIDELINES FOR VERIFICATION OF DAMAGE STABILITY REQUIREMENTS FOR TANKERS AND BULK CARRIERS**

### **General**

13.1 The Sub-Committee recalled that MSC 83, having considered document MSC 83/25/14, wherein Denmark *et al.*, proposed to develop guidelines for the verification of damage stability requirements contained in existing instruments for oil, chemical and gas tankers and to consider their application to new and existing tankers to ensure consistent verification of damage stability on such ships prior to departure, and document MSC 83/25/16, wherein Norway proposed to broaden the scope of the proposed guidelines to also cover bulk carrier, had included, in the Sub-Committee’s work programme and the provisional agenda for SLF 51, the high-priority item on “Guidelines for verification of damage stability requirements for tankers and bulk carriers”, with a target completion date of 2009, in co-operation with the DE and STW Sub-Committees as necessary, and had referred the relevant documents, listed in paragraph 4 of document SLF 51/13, to the Sub-Committee for consideration as appropriate.

### **Guidelines for verification of damage stability requirements for tankers and bulk carriers**

13.2 The Sub-Committee considered document SLF 51/13/1 (Denmark, Finland, Germany, Norway, Sweden, United Kingdom and INTERTANKO), which proposed draft Guidelines for verification of damage stability for tankers, attaching also guidelines on standardized calculation method for approval of tank vessel damage stability, together with:

- .1 document SLF 51/13/2 (United Kingdom), proposing additional clauses for insertion into draft Guidelines on standardized calculation method for approval of tank vessel damage stability, upon which unanimity could not be reached by the co-sponsors of document SLF 51/13/1;
- .2 document SLF 51/13/3 (Germany and Netherlands), proposing, for existing tankers and bulk carriers, to retain the possibility to check the damage stability prior to departure, by verifying if the actual loading condition is within the range of loading conditions listed in the stability booklet;

- .3 document SLF 51/13/4 (IPTA, OCIMF and ICS), providing comments on the draft Guidelines and suggesting that information should be provided about the extent of the alleged non-compliance, including the number and type of vessels involved, in order for the Sub-Committee to be in a position to make an informed decision on this issue; and
- .4 document SLF 51/13/5 (Norway), containing various comments on the draft Guidelines proposed in document SLF 51/13/1, in particular suggestion that, as a number of issues addressed in the draft Guidelines are already included in MSC/Circ.406/Rev.1, this circular may need a review to avoid conflicts.

13.3 Following extensive debate, the Sub-Committee noted:

- .1 that the majority of the delegations considered that no justification or compelling need has been demonstrated and strongly supported the view of IPTA, OCIMF and ICS that more information on the alleged non-compliance (e.g., type, size, age and the number of vessels involved) is needed to decide on the course of action on the matter;
- .2 IPTA's explanation that, due to their high degree of subdivision, chemical tankers normally have high margins of damage stability and that there is widespread understanding within the industry that damage stability issues are dealt with at the design stage prior to the issuing of Certificates of Fitness;
- .3 the views of delegations, supporting the proposal to retain the possibility to check the damage stability prior to departure, for existing tankers and bulk carriers, by verifying if the actual loading condition is within the range of loading conditions listed in the stability booklet;
- .4 the view of some delegations that there is an urgent need to develop guidelines for the verification of damage stability requirements for tankers prior to departure, in particular for PSC purposes; and
- .5 IACS's intention to submit the approval procedures used by its members for damage stability calculation to SLF 52, should they be requested.

13.4 Subsequently, the Sub-Committee, acknowledging the importance of complying with relevant damage stability requirements for operational loading conditions, invited Member Governments and international organizations to submit the information referred to in paragraph 13.3.1.

#### **Extension of the target completion date**

13.5 Since there is no session in 2009, the Sub-Committee requested the Committee to extend the target completion date of the item to 2010.

## 14 WORK PROGRAMME AND AGENDA FOR SLF 52

### Work programme and agenda for SLF 52

14.1 Taking into account the progress made at the session and the provisions of the agenda management procedure contained in paragraphs 3.13 to 3.25 of the Guidelines on the organization and method of work (MSC-MEPC.1/Circ.2), the Sub-Committee revised its work programme (SLF 51/WP.4) based on that approved by MSC 84 (SLF 51/2/2, annex) and prepared the proposed revised work programme and provisional agenda for SLF 52. While reviewing the work programme, the Sub-Committee agreed to invite the Committee to:

- .1 delete the following work programme items, as work on them has been completed:
  - .1.1 item 1 – Analysis of intact stability casualty records;
  - .1.2 item 2 – Analysis of damage cards;
  - .1.3 item H.1 – Development of explanatory notes for harmonized SOLAS chapter II-1;
  - .1.4 item H.5 – Guidelines for uniform operating limitations on high-speed craft; and
  - .1.5 item H.9 – Guidelines for drainage systems in closed vehicle and ro-ro spaces and special category spaces;
- .2 extend the target completion dates of the following work programme items:
  - .2.1 item H.4 – Development of options to improve effect on ship design and safety of the 1969 TM Convention, to 2011;
  - .2.2 item H.6 – Time-dependent survivability of passenger ships in damaged condition, to 2011;
  - .2.3 item H.7 – Guidance on the impact of open watertight doors on existing and new ship survivability, to 2010;
  - .2.4 item H.8 – Stability and sea-keeping characteristics of damaged passenger ships in a seaway when returning to port by own power or under tow, to 2011; and
  - .2.5 item H.10 – Guidelines for verification of damage stability requirements for tankers and bulk carriers, to 2010;
- .3 replace the number of sessions needed for completion of the following work programme items by the target completion date, as the items have been included in the provisional agenda for SLF 52:
  - .3.1 item H.11 – Safety provisions applicable to tenders operating from passenger ships 2012;

- .3.2 item H.12 – Damage stability regulations for ro-ro passenger ships 2011;
- .3.3 item H.13 – Development of an agreement on the implementation of the 1993 Torremolinos Protocol 2011;
- .4 include the following new item in the Sub-Committee’s work programme, taking into account the justification provided (see paragraph 3.25 and annex 3):
  - .4.1 item H.11 – Revision of SOLAS chapter II-1 subdivision and damage stability regulations 2 sessions
- .5 change the title of item H.3 to read “Development of new generation intact stability criteria” and extend the target completion date of the item to 2012; and
- .6 renumber the work programme items accordingly.

14.2 The Sub-Committee invited the Committee to approve the proposed revised work programme of the Sub-Committee and provisional agenda for SLF 52, set out in annex 6. In deleting the continuous items on “Analysis of intact stability casualty records” and “Analysis of damage cards”, the Sub-Committee, having noted that MSC 70 had included, in the work programmes of the BLG, DSC, COMSAR, NAV, DE and STW Sub-Committees (in addition to having previously included the same item in the work programmes of the FP and SLF Sub-Committees), a continuous item on “Casualty analysis”, coordinated by the FSI Sub-Committee, emphasized that Member Governments should continue submitting their reports using format contained in MSC/Circ.953, as the accumulation of this information would be essential to any future improvement of intact stability and the subdivision and damage stability requirements contained in the respective IMO instruments.

### **Strategic plan for the Organization and High-level Action Plan**

14.3 With regard to the Strategic Plan for the Organization (for the six-year period 2008-2013) and updated High-level Action Plan of the Organization and priorities for the 2008-2009 biennium, the Sub-Committee noted document SLF 51/14 (Secretariat), informing related recommendations for necessary action, endorsed by the Council, which are listed in paragraph 2 of document SLF 51/14, in particular that:

- .1 all IMO organs should, sufficiently early in their agendas for each session, set aside adequate time for the systematic consideration of the high-level actions and their associated priorities, and their connection to the strategic directions;
- .2 when considering their work programmes and provisional agendas for their next sessions, all IMO organs should, under each item, cross-reference the related strategic directions and high-level actions; and
- .3 Sub-Committees should, in reporting to the Committees on their work programmes, report on the status of their planned outputs.

14.4 The Sub-Committee also noted that MSC 84 had agreed to the following procedure, as described in paragraphs 4 to 6 of document SLF 51/14:

- .1 the Sub-Committees, at each respective session, should prepare and annex to their respective reports a report on the status of their planned outputs in the High-level Action Plan for the respective biennium in the format proposed in the annex to document STW 39/WP.1, for the Committee's consideration and endorsement; and
- .2 regarding the terminologies to be used to describe the status of the planned outputs, the term "ongoing" should not be used and actual progress of work must be reflected and, in addition, the status of work on the long-term work programmes should also be provided.

14.5 In this regard, the Sub-Committee, having considered the draft status of planned outputs in the High-level Action Plan for the 2008-2009 biennium relating to the Sub-Committee's work, based on the Annex to resolution A.990(25), (SLF 51/WP.4, annex 4), agreed to the status of the planned outputs, as set out in annex 7. In considering the status of planned outputs, the Sub-Committee invited the Committee to note that, since there is no meeting allocated in 2009, no further report on the status of the planned outputs, relating to the Sub-Committee's work, will be provided for the remaining period in the 2008-2009 biennium.

#### **Arrangements for the next session**

14.6 The Sub-Committee agreed, in principle, to establish, at SLF 52, working and drafting groups on the following subjects:

- .1 subdivision and damage stability;
- .2 intact stability;
- .3 fishing vessel safety; and
- .4 1969 TM Convention,

and that the Chairman, in consultation with the Secretariat, should undertake the final selection, taking into account the documentation on the above subjects and should inform the Sub-Committee accordingly in good time for SLF 52.

#### **Date of the next session**

14.7 The Sub-Committee noted that the fifty-second session of the Sub-Committee had been tentatively scheduled to take place in January 2010 (see also paragraph 2.3).

### **15 ELECTION OF CHAIRMAN AND VICE-CHAIRMAN FOR 2009**

15.1 The Sub-Committee, in accordance with the Rules of Procedure of the Maritime Safety Committee, unanimously re-elected Mr. R. Gehling (Australia) as Chairman and Mr. Z. Szozda (Poland) as Vice-Chairman, both for 2009.

## **16 ANY OTHER BUSINESS**

### **Recommendations, guidelines and other non-mandatory instruments**

16.1 The Sub-Committee recalled that MSC 83, when considering the list of codes, recommendations, guidelines and other safety- and security-related non-mandatory instruments relating to the work of the Committee (MSC 82/18/1 and MSC 82/INF.12), had referred the detailed consideration of the list to the relevant sub-committees for the identification of those instruments which might be relevant in the context of the collection of information on their implementation.

16.2 The Sub-Committee noted a part of document SLF 51/16 (Secretariat), containing at annex the list of codes, recommendations, guidelines and other non-mandatory instruments under the purview of the Sub-Committee, which was requested to review by MSC 83, and informing that MSC 83 noted that the Secretariat was developing a module of the IMO Global Integrated Shipping Information System (GISIS) on safety- and security-related non-mandatory requirements and recommendations, on the basis of MSC/Circ.815, and that the module could also contain information on the status of implementation of non-mandatory instruments to be kept updated by the Member States themselves using direct recording facilities. The module could also record, on a voluntary basis, for each instrument the national legislation adopted for its implementation – including the ability to upload its full text – the application criteria and the status of the instrument with regard to amendments.

16.3 In this context of the issue, the Sub-Committee also noted that FSI 16, having supported the view that the burden of keeping the information on Member States implementation, on a voluntary basis, and uploaded documentation should be kept minimal, had agreed to the list of non-mandatory instruments for reference purposes, but to be limited to Assembly and Committee resolutions, for the collection of information on the implementation of non-mandatory instruments by individual Member States.

16.4 The Sub-Committee, in view of the length of the list attached to document SLF 51/16, containing 79 non-mandatory instruments, and the information received regarding the further development of GISIS, decided to support, in general, the development of a GISIS module on non-mandatory requirements and recommendations to be kept updated by the Secretariat. In this regard, the Sub-Committee supported the view that the GISIS module to be developed should be efficient and user-friendly with good search functions.

### **Load Lines Convention- and Protocol-related matters**

#### ***Safety gap between the 1966 LL Convention and the 1988 LL Protocol***

16.5 The Sub-Committee was informed (paragraph 6 of document SLF 51/2) that MSC 83, having considered document MSC 83/22/3 (IACS), stating that there is a safety gap that arises for ships built under the provisions of the 1988 LL Protocol (as modified by the 2003 amendments (resolution MSC.143(77)) which entered into force on 1 January 2005), versus ships built to the 1966 LL Convention, had noted that such a safety gap can be removed, if States not Parties to the Protocol take action as indicated in paragraphs 4.2 and 4.3 of the document, and had referred this issue to SLF 51 for consideration and advice to MSC 85.

16.6 After consideration, the Sub-Committee noted the proposals by IACS to resolve the problem, as described in paragraph 4 of document MSC 83/22/3, and, having appreciated IACS bringing the issue to the Organization's attention, was of the opinion that it would be primarily for Member States to take appropriate action to address the problem. In this context, the Sub-Committee also noted that IACS had not received relevant instructions from about 95 States which are not Parties to the 1988 LL Protocol.

16.7 The Sub-Committee requested the Secretariat to inform MSC 85 accordingly.

***Ambiguities in regulation 24(4) of the 1988 LL Protocol relating to minimum freeing port area calculations on vessels with open superstructures***

16.8 The Sub-Committee was informed (paragraph 7 of document SLF 51/2) that MSC 83, having considered document MSC 83/22/5 (United Kingdom), stating that there were some ambiguities in regulation 24(4) of the 1988 LL Protocol, as amended by resolution MSC.143(77), relating to minimum freeing port area calculations on vessels with open superstructures, had invited Member Governments, in particular IACS, to further examine the relevant interpretations and referred the document to SLF 51 for consideration and advice to MSC 85, as appropriate.

16.9 The Sub-Committee noted the IACS's intention to submit relevant information to the Committee regarding the above-mentioned ambiguities in regulation 24(4) of the 1988 LL Protocol in relation to IACS Unified Interpretation LL60.

16.10 The Committee is invited to note the course of action taken by the Sub-Committee on the matter.

**17 ACTION REQUESTED OF THE COMMITTEE**

17.1 The Maritime Safety Committee is invited to:

- .1 adopt the draft MSC resolution on Explanatory Notes to the SOLAS chapter II-1 subdivision and damage stability regulations (paragraph 3.20 and annex 1);
- .2 approve the proposed amendments to the footnotes to the revised SOLAS regulations II-1/4.1 and II-1/13.7.6 and request the Secretariat to amend the footnotes in the next consolidated edition of SOLAS (paragraph 3.23);
- .3 approve the draft MSC circular on Guidelines for flooding detection systems required by SOLAS regulation II-1/22-1 (paragraph 3.24 and annex 2);
- .4 consider the justification for inclusion of a new item on "Revision of SOLAS chapter II-1 subdivision and stability regulations" in the Sub-Committee's work programme (paragraph 3.25 and annex 3);
- .5 approve the draft MSC circular on Early application of the International Code on Intact Stability, 2008 (paragraph 4.24 and annex 4);
- .6 approve the change of the present title of the item on "Revision of the Intact Stability Code" to "Development of new generation intact stability criteria", reflecting the Sub-Committee's current work on the subject (paragraph 4.26);
- .7 note that the Sub-Committee, with regard to the impact of small pleasure and fishing craft on the marine environment, agreed that in view of a minimal expertise in environmental matters in the Sub-Committee, relevant environmental



- issues should be addressed by the MEPC, in consultation with other UN agencies and non-governmental organizations (paragraph 5.26);
- .8 endorse the Sub-Committee's course of action regarding the development of the Agreement on the implementation of the 1993 Torremolinos Protocol, noting, in particular, that the Sub-Committee agreed that the Secretariat should initiate a consultation process with States, on the basis of the questionnaire developed by the Sub-Committee, and also agreed to the Roadmap towards entry into force of the 1993 Torremolinos Protocol (paragraphs 5.27 to 5.30 and annex 5);
  - .9 note the outcome of the Sub-Committee's consideration on development of options to improve effect on ship design and safety of the 1969 TM Convention, in particular with regard to the incorporation of the tacit acceptance procedure for amendments in the Convention (paragraphs 6.5 to 6.13);
  - .10 note the Sub-Committee's outcome on the Guidelines for uniform operating limitations on high-speed craft, in particular that the work on the item has been completed (paragraphs 7.5 and 7.6);
  - .11 note that the Sub-Committee, with regard to the development of the Guidelines for drainage systems in closed vehicle and ro-ro spaces and special category spaces, agreed to the specifications for the drainage capacity and the scupper grating construction, for referral to FP 53 for coordination purpose, and considered the work on the item completed (paragraphs 12.3 and 12.4);
  - .12 approve the proposed revised work programme of the Sub-Committee and provisional agenda for SLF 52 (paragraphs 14.1 and 14.2 and annex 6);
  - .13 endorse the status of planned outputs in the High-level Action Plan for the 2008-2009 biennium relating to the Sub-Committee's work and note that, since there is no meeting allocated in 2009, no further report on the status of the planned outputs will be provided for the remaining period in the 2008-2009 biennium (paragraph 14.5 and annex 7);
  - .14 note that the Sub-Committee, with regard to the Committee's instruction to identify those non-mandatory instruments for which information on their implementation should be collected, supported, in general, the development of a GISIS module on non-mandatory instruments and recommendations to be kept updated by the Secretariat (paragraph 16.4);
  - .15 note the Sub-Committee's opinion that, in respect of safe gap that arises for ships built under the provisions of the 1988 LL Protocol versus ships built to the 1966 LL Convention, it would be for Member States to take appropriate action to address the problem, and decide as appropriate (paragraph 16.6);
  - .16 note the Sub-Committee's consideration regarding ambiguities in regulation 24(4) of the 1988 LL Protocol, relating to minimum freeing port area calculations on vessels with open superstructures, in particular the IACS's intention to submit relevant information to the Committee (paragraphs 16.8 and 16.9); and
  - .17 approve the report in general.

\*\*\*



**ANNEX 1****DRAFT MSC RESOLUTION****EXPLANATORY NOTES TO THE SOLAS CHAPTER II-1 SUBDIVISION AND  
DAMAGE STABILITY REGULATIONS**

THE MARITIME SAFETY COMMITTEE,

RECALLING Article 28(b) of the Convention on the International Maritime Organization concerning the function of the Committee,

RECALLING ALSO that, by resolution MSC.216(82), it adopted the regulations on subdivision and damage stability as contained in SOLAS chapter II-1 which are based on the probabilistic concept, using the probability of survival after collision as a measure of ships' safety in a damaged condition,

NOTING that, at the eighty-second session, it approved Interim Explanatory Notes to the SOLAS chapter II-1 subdivision and damage stability regulations (MSC.1/Circ.1226), to assist Administrations in the uniform interpretation and application of the aforementioned subdivision and damage stability regulations,

BEING DESIROUS that definitive Explanatory Notes should be adopted when more experience in the application of the the aforementioned subdivision and damage stability regulations and the Interim Explanatory Notes had been gained,

RECOGNIZING that the appropriate application of the Explanatory Notes is essential for ensuring the uniform application of the SOLAS chapter II-1 subdivision and damage stability regulations,

HAVING CONSIDERED, at its eighty-fifth session, the recommendations made by the Sub-Committee on Stability and Load Lines and on Fishing Vessels Safety at its fifty-first session,

1. ADOPTS the Explanatory Notes to the SOLAS chapter II-1 subdivision and damage stability regulations set out in the Annex to the present resolution;
2. URGES Governments and all parties concerned to utilize the Explanatory Notes when applying the SOLAS chapter II-1 subdivision and damage stability regulations adopted by resolution MSC.216(82).

**EXPLANATORY NOTES TO THE SOLAS CHAPTER II-1  
SUBDIVISION AND DAMAGE STABILITY REGULATIONS**

**Contents**

**Part A – INTRODUCTION**

**Part B – GUIDANCE ON INDIVIDUAL SOLAS CHAPTER II-1 SUBDIVISION AND  
DAMAGE STABILITY REGULATIONS**

Regulation 1	Application
Regulation 2	Definitions
Regulation 4	General
Regulation 5	Intact stability information
Regulation 5-1	Stability information to be supplied to the master
Regulation 6	Required subdivision index $R$
Regulation 7	Attained subdivision index $A$
Regulation 7-1	Calculation of the factor $p_i$
Regulation 7-2	Calculation of the factor $s_i$
Regulation 7-3	Permeability
Regulation 8	Special requirements concerning passenger ship stability
Regulation 8-1	System capabilities after a flooding casualty on passenger ships
Regulation 9	Double bottoms in passenger ships and cargo ships other than tankers
Regulation 10	Construction of watertight bulkheads
Regulation 12	Peak and machinery space bulkheads, shaft tunnels, etc.
Regulation 13	Openings in watertight bulkheads below the bulkhead deck in passenger ships
Regulation 13-1	Openings in watertight bulkheads and internal decks in cargo ships
Regulation 15	Openings in the shell plating below the bulkhead deck of passenger ships and the freeboard deck of cargo ships
Regulation 15-1	External openings in cargo ships
Regulation 16	Construction and initial tests of watertight doors, sidescuttles, etc.
Regulation 17	Internal watertight integrity of passenger ships above the bulkhead deck
Appendix	Guidelines for the preparation of subdivision and damage stability calculations

## PART A

### INTRODUCTION

1 The harmonized SOLAS regulations on subdivision and damage stability, as contained in SOLAS chapter II-1, are based on a probabilistic concept which uses the probability of survival after collision as a measure of ships' safety in a damaged condition. This probability is referred to as the "attained subdivision index  $A$ " in the regulations. It can be considered an objective measure of ships' safety and, ideally, there would be no need to supplement this index by any deterministic requirements.

2 The philosophy behind the probabilistic concept is that two different ships with the same attained index are of equal safety and, therefore, there is no need for special treatment of specific parts of the ship, even if they are able to survive different damages. The only areas which are given special attention in the regulations are the forward and bottom regions, which are dealt with by special subdivision rules provided for cases of ramming and grounding.

3 Only a few deterministic elements, which were necessary to make the concept practicable, have been included. It was also necessary to include a deterministic "minor damage" on top of the probabilistic regulations for passenger ships to avoid ships being designed with what might be perceived as unacceptably vulnerable spots in some part of their length.

4 It is easily recognized that there are many factors that will affect the final consequences of hull damage to a ship. These factors are random and their influence is different for ships with different characteristics. For example, it would seem obvious that in ships of similar size carrying different amounts of cargo, damages of similar extents may lead to different results because of differences in the range of permeability and draught during service. The mass and velocity of the ramming ship is obviously another random variable.

5 Due to this, the effect of a three-dimensional damage to a ship with given watertight subdivision depends on the following circumstances:

- .1 which particular space or group of adjacent spaces is flooded;
- .2 the draught, trim and intact metacentric height at the time of damage;
- .3 the permeability of affected spaces at the time of damage;
- .4 the sea state at the time of damage; and
- .5 other factors such as possible heeling moments due to unsymmetrical weights.

6 Some of these circumstances are interdependent and the relationship between them and their effects may vary in different cases. Additionally, the effect of hull strength on penetration will obviously have some effect on the results for a given ship. Since the location and size of the damage is random, it is not possible to state which part of the ship becomes flooded. However, the probability of flooding a given space can be determined if the probability of occurrence of certain damages is known from experience, that is, damage statistics. The probability of flooding a space is then equal to the probability of occurrence of all such damages which just open the considered space to the sea.

7 For these reasons and because of mathematical complexity as well as insufficient data, it would not be practicable to make an exact or direct assessment of their effect on the probability that a particular ship will survive a random damage if it occurs. However, accepting some approximations or qualitative judgments, a logical treatment may be achieved by using the probability approach as the basis for a comparative method for the assessment and regulation of ship safety.

8 It may be demonstrated by means of probability theory that the probability of ship survival should be calculated as the sum of probabilities of its survival after flooding each single compartment, each group of two, three, etc., adjacent compartments multiplied, respectively, by the probabilities of occurrence of such damages leading to the flooding of the corresponding compartment or group of compartments.

9 If the probability of occurrence for each of the damage scenarios the ship could be subjected to is calculated and then combined with the probability of surviving each of these damages with the ship loaded in the most probable loading conditions, we can determine the attained index  $A$  as a measure for the ship's ability to sustain a collision damage.

10 It follows that the probability that a ship will remain afloat without sinking or capsizing as a result of an arbitrary collision in a given longitudinal position can be broken down to:

- .1 the probability that the longitudinal centre of damage occurs in just the region of the ship under consideration;
- .2 the probability that this damage has a longitudinal extent that only includes spaces between the transverse watertight bulkheads found in this region;
- .3 the probability that the damage has a vertical extent that will flood only the spaces below a given horizontal boundary, such as a watertight deck;
- .4 the probability that the damage has a transverse penetration not greater than the distance to a given longitudinal boundary; and
- .5 the probability that the watertight integrity and the stability throughout the flooding sequence is sufficient to avoid capsizing or sinking.

11 The first three of these factors are solely dependent on the watertight arrangement of the ship, while the last two depend on the ship's shape. The last factor also depends on the actual loading condition. By grouping these probabilities, calculations of the probability of survival, or attained index  $A$ , have been formulated to include the following probabilities:

- .1 the probability of flooding each single compartment and each possible group of two or more adjacent compartments; and
- .2 the probability that the stability after flooding a compartment or a group of two or more adjacent compartments will be sufficient to prevent capsizing or dangerous heeling due to loss of stability or to heeling moments in intermediate or final stages of flooding.

12 This concept allows a rule requirement to be applied by requiring a minimum value of  $A$  for a particular ship. This minimum value is referred to as the “required subdivision index  $R$ ” in the present regulations and can be made dependent on ship size, number of passengers or other factors legislators might consider important.

13 Evidence of compliance with the rules then simply becomes:

$$A \geq R$$

13.1 As explained above, the attained subdivision index  $A$  is determined by a formula for the entire probability as the sum of the products for each compartment or group of compartments of the probability that a space is flooded, multiplied by the probability that the ship will not capsize or sink due to flooding of the considered space. In other words, the general formula for the attained index can be given in the form:

$$A = \sum p_i s_i$$

13.2 Subscript “ $i$ ” represents the damage zone (group of compartments) under consideration within the watertight subdivision of the ship. The subdivision is viewed in the longitudinal direction, starting with the aftmost zone/compartment.

13.3 The value of “ $p_i$ ” represents the probability that only the zone “ $i$ ” under consideration will be flooded, disregarding any horizontal subdivision, but taking transverse subdivision into account. Longitudinal subdivision within the zone will result in additional flooding scenarios, each with its own probability of occurrence.

13.4 The value of “ $s_i$ ” represents the probability of survival after flooding the zone “ $i$ ” under consideration.

14 Although the ideas outlined above are very simple, their practical application in an exact manner would give rise to several difficulties if a mathematically perfect method was to be developed. As pointed out above, an extensive but still incomplete description of the damage will include its longitudinal and vertical location as well as its longitudinal, vertical and transverse extent. Apart from the difficulties in handling such a five-dimensional random variable, it is impossible to determine its probability distribution very accurately with the presently available damage statistics. Similar limitations are true for the variables and physical relationships involved in the calculation of the probability that a ship will not capsize or sink during intermediate stages or in the final stage of flooding.

15 A close approximation of the available statistics would result in extremely numerous and complicated computations. In order to make the concept practicable, extensive simplifications are necessary. Although it is not possible to calculate the exact probability of survival on such a simplified basis, it has still been possible to develop a useful comparative measure of the merits of the longitudinal, transverse and horizontal subdivision of a ship.

## **PART B**

### **GUIDANCE ON INDIVIDUAL SOLAS CHAPTER II-1 SUBDIVISION AND DAMAGE STABILITY REGULATIONS**

#### **REGULATION 1 – APPLICATION**

##### **Regulation 1.3**

If a passenger ship built before 1 January 2009 undergoes alterations or modifications of major character, it may still remain under the damage stability regulations applicable to ships built before 1 January 2009, except in the case of a cargo ship being converted to a passenger ship.

#### **REGULATION 2 – DEFINITIONS**

##### **Regulation 2.1**

Subdivision length ( $L_s$ ) – Different examples of  $L_s$  showing the buoyant hull and the reserve buoyancy are provided in the figures below. The limiting deck for the reserve buoyancy may be partially watertight.



The maximum possible vertical extent of damage above the baseline is  $d_s + 12.5$  metres.

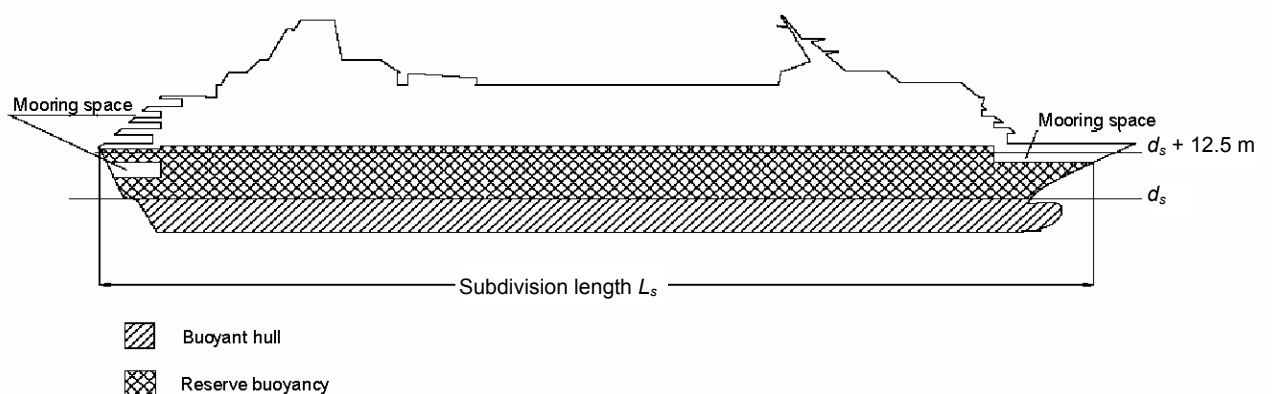
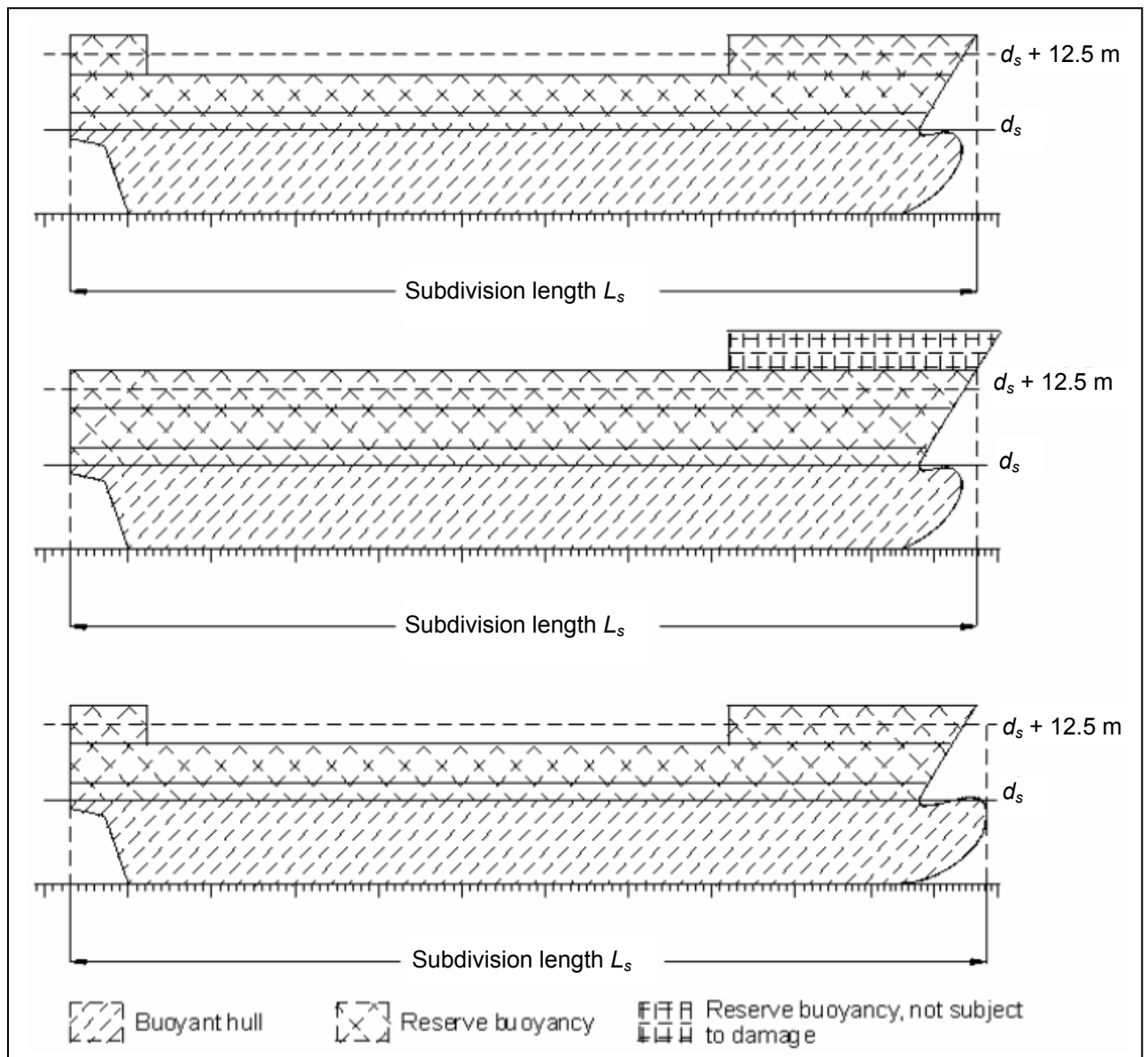

## **Regulation 2.6**

Freeboard deck – See Explanatory Notes for regulation 13-1\* for the treatment of a stepped freeboard deck with regard to watertightness and construction requirements.

## **Regulation 2.11**

Light service draught ( $d_l$ ) – The light service draught ( $d_l$ ) represents the lower draught limit of the minimum required  $GM$  (or maximum allowable  $KG$ ) curve. It corresponds, in general, to the ballast arrival condition with 10% consumables for cargo ships. For passenger ships, it corresponds, in general, to the arrival condition with 10% consumables, a full complement of passengers and crew and their effects, and ballast as necessary for stability and trim. The 10% arrival condition is not necessarily the specific condition that must be used for all ships, but represents, in general, a suitable lower limit for all loading conditions. This is understood to not include docking conditions or other non-voyage conditions.

## **Regulation 2.19**

Bulkhead deck – See Explanatory Notes for regulation 13 for the treatment of a stepped bulkhead deck with regard to watertightness and construction requirements.

---

\* References to regulations in these Guidelines are to regulations of SOLAS chapter II-1, unless expressly provided otherwise.

## REGULATION 4 – GENERAL

### Regulation 4.1

Cargo ships complying with the subdivision and damage stability regulations of other IMO instruments listed in the footnote are not required to comply with part B-1, regulations 6, 7, 7-1, 7-2 and 7-3, but must comply with the regulations indicated in the table below.

Regulation	Applies
Part B-1	
5	X
5-1	X
Part B-2	
9	X <sup>(1)</sup>
10	X
11	X
12	X
13-1	X
15	X
15-1	X
16	X
16-1	X
Part B-4	
19	X
22	X
24	X
25	X <sup>(2)</sup>

<sup>(1)</sup> Only applies to cargo ships other than tankers.

<sup>(2)</sup> Only applies to single hold cargo ships other than bulk carriers.

### Regulation 4.1, footnote .1

“OBO ships” mean *combination carriers* as defined in SOLAS regulation II-2/3.14.

### Regulation 4.4

See Explanatory Notes for regulation 7-2.2, for information and guidance related to these provisions.

## REGULATION 5 – INTACT STABILITY INFORMATION

Reference is made to MSC/Circ.1158 (Unified interpretation of SOLAS chapter II-1) regarding lightweight check.

## **REGULATION 5-1 – STABILITY INFORMATION TO BE SUPPLIED TO THE MASTER**

### **Regulation 5-1.2**

Any limiting *GM* (or *KG*) requirements arising from provisions in regulation 6.1 (regarding partial attained subdivision indices), regulation 8 or regulation 9, which are in addition to those described in regulation 5-1.4, should also be taken into account when developing this information.

### **Regulations 5-1.3 and 5-1.4 (see also regulation 7.2)**

1 Linear interpolation of the limiting values between the draughts  $d_s$ ,  $d_p$  and  $d_l$  is only applicable to minimum *GM* values. If it is intended to develop curves of maximum permissible *KG*, a sufficient number of  $KM_T$  values for intermediate draughts must be calculated to ensure that the resulting maximum *KG* curves correspond with a linear variation of *GM*. When light service draught is not with the same trim as other draughts,  $KM_T$  for draughts between partial and light service draught must be calculated for trims interpolated between trim at partial draught and trim at light service draught.

2 In cases where the operational trim range is intended to exceed  $\pm 0.5\%$  of  $L_s$ , the original *GM* limit line should be designed in the usual manner with the deepest subdivision draught and partial subdivision draught calculated at level trim and actual service trim used for the light service draught. Then additional sets of *GM* limit lines should be constructed on the basis of the operational range of trims which is covered by loading conditions of partial subdivision draught and deepest subdivision draught ensuring that intervals of  $1\% L_s$  are not exceeded. For the light service draught  $d_l$  only one trim is to be considered. The sets of *GM* limit lines are combined to give one envelope limiting *GM* curve. The effective trim range of the curve should be clearly stated.

## **REGULATION 6 – REQUIRED SUBDIVISION INDEX R**

### **Regulation 6.1**

To demonstrate compliance with these provisions, see the Guidelines for the preparation of subdivision and damage stability calculations, set out in the appendix, regarding the presentation of damage stability calculation results.

### **Regulation 6.2.4**

Regarding the term “reduced degree of hazard”, the following interpretation should be applied: A lesser value of  $N$ , but in no case less than  $N = N_1 + N_2$ , may be allowed at the discretion of the Administration for passenger ships, which, in the course of their voyages, do not proceed more than 20 miles from the nearest land.

## REGULATION 7 – ATTAINED SUBDIVISION INDEX *A*

### Regulation 7.1

1 The probability of surviving after collision damage to the ship's hull is expressed by the index *A*. Producing an index *A* requires calculation of various damage scenarios defined by the extent of damage and the initial loading conditions of the ship before damage. Three loading conditions should be considered and the result weighted as follows:

$$A = 0.4A_s + 0.4A_p + 0.2A_l$$

where the indices *s*, *p* and *l* represent the three loading conditions and the factor to be multiplied to the index indicates how the index *A* from each loading condition is weighted.

2 The method of calculating *A* for a loading condition is expressed by the formula:

$$A_c = \sum_{i=1}^{i=t} p_i [v_i s_i]$$

2.1 The index *c* represents one of the three loading conditions, the index *i* represents each investigated damage or group of damages and *t* is the number of damages to be investigated to calculate *A<sub>c</sub>* for the particular loading condition.

2.2 To obtain a maximum index *A* for a given subdivision, *t* has to be equal to *T*, the total number of damages.

3 In practice, the damage combinations to be considered are limited either by significantly reduced contributions to *A* (i.e. flooding of substantially larger volumes) or by exceeding the maximum possible damage length.

4 The index *A* is divided into partial factors as follows:

*p<sub>i</sub>* The *p* factor is solely dependent on the geometry of the watertight arrangement of the ship.

*v<sub>i</sub>* The *v* factor is dependent on the geometry of the watertight arrangement (decks) of the ship and the draught of the initial loading condition. It represents the probability that the spaces above the horizontal subdivision will not be flooded.

*s<sub>i</sub>* The *s* factor is dependent on the calculated survivability of the ship after the considered damage for a specific initial condition.

5 Three initial loading conditions should be used for calculating the index *A*. The loading conditions are defined by their mean draught *d*, trim and *GM* (or *KG*). The mean draught and trim are illustrated in the figure below.

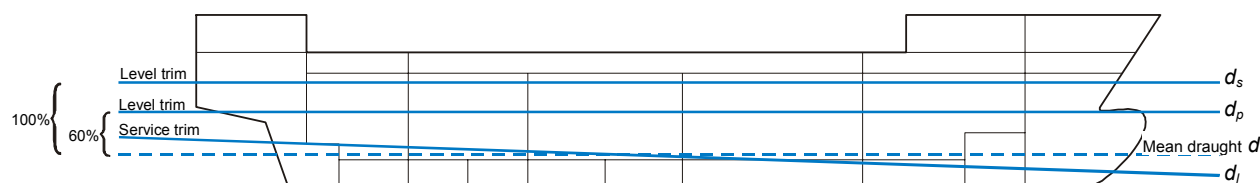

6 The  $GM$  (or  $KG$ ) values for the three loading conditions could, as a first attempt, be taken from the intact stability  $GM$  (or  $KG$ ) limit curve. If the required index  $R$  is not obtained, the  $GM$  (or  $KG$ ) values may be increased (or reduced), implying that the intact loading conditions from the intact stability book must now meet the  $GM$  (or  $KG$ ) limit curve from the damage stability calculations derived by linear interpolation between the three  $GM$ s.

### Regulation 7.2

1 The calculations for differing trim should be carried out with the same initial trim for the partial and deepest subdivision draughts. For the light service draught, the actual service trim should be used (refer to the Explanatory Notes for regulation 2.11).

2 Each combination of the index within the formula given in regulation 7.1 should not be less than the requirement given in regulation 6.2. Each partial index  $A$  should comply with the requirements of regulation 6.1.

3 Example:

Based on the  $GM$  limiting curves obtained from damage stability calculations of each trim, an envelope curve covering all calculated trim values should be developed.

Calculations covering different trim values should be carried out in steps not exceeding 1% of  $L_s$ . The whole range including intermediate trims should be covered by the damage stability calculations. Refer to the example showing an envelope curve obtained from calculations of 0 trim and 1% of  $L_s$ .

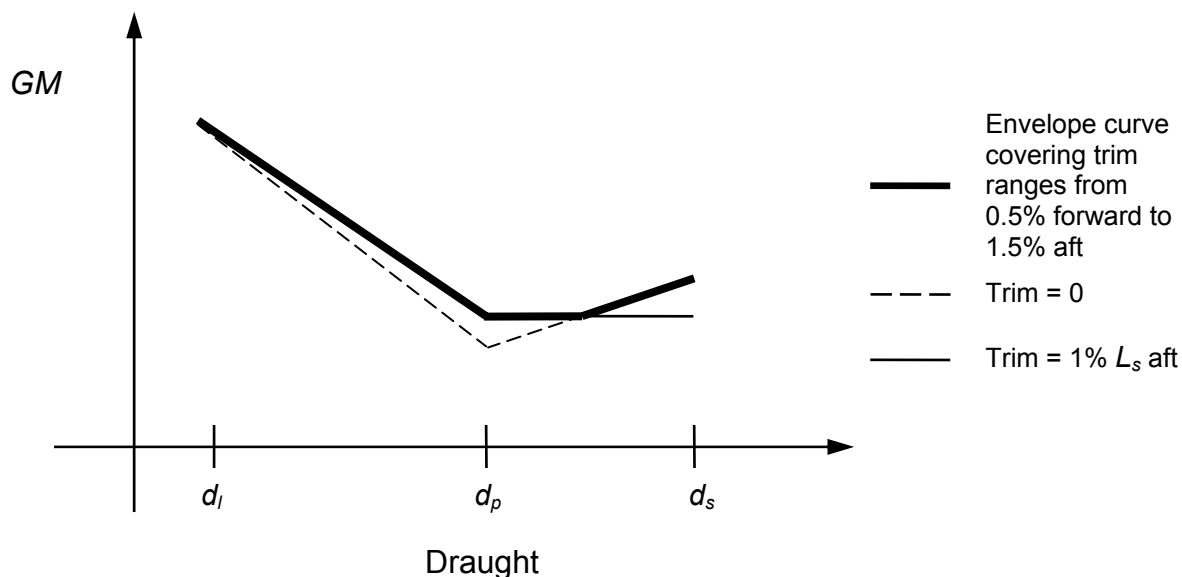

### Regulation 7.5

1 With the same intent as wing tanks, the summation of the attained index  $A$  must reflect effects caused by all watertight bulkheads and flooding boundaries within the damaged zone. It is not correct to assume damage only to the centreline and ignore changes in subdivision that would reflect lesser contributions.

2 In the forward and aft ends of the ship where the sectional breadth is less than the ship's breadth  $B$ , transverse damage penetration can extend beyond the centreline bulkhead. This application of the transverse extent of damage is consistent with the methodology to account for the localized statistics which are normalized on the greatest moulded breadth  $B$  rather than the local breadth.

3 Where longitudinal corrugated bulkheads are fitted in wing compartments or on the centreline, they may be treated as equivalent plane bulkheads provided the corrugation depth is of the same order as the stiffening structure. The same principle may also be applied to transverse corrugated bulkheads.

### **Regulation 7.7**

1 Pipes and valves directly adjacent to a bulkhead or to a deck can be considered to be part of the bulkhead or deck, provided the separation distance is of the same order as the bulkhead or deck stiffening structure. The same applies for small recesses, drain wells, etc.

2 The provision for allowing "minor progressive flooding" should be limited to pipes penetrating a watertight subdivision with a total cross-sectional area of not more than  $710 \text{ mm}^2$  between any two watertight compartments.

### **REGULATION 7-1 – CALCULATION OF THE FACTOR $p_i$**

#### **General**

1 The definitions below are intended to be used for the application of part B-1 only.

2 In regulation 7-1, the words "compartment" and "group of compartments" should be understood to mean "zone" and "adjacent zones".

3 Zone – a longitudinal interval of the ship within the subdivision length.

4 Room – a part of the ship, limited by bulkheads and decks, having a specific permeability.

5 Space – a combination of rooms.

6 Compartment – an onboard space within watertight boundaries.

7 Damage – the three dimensional extent of the breach in the ship.

8 For the calculation of  $p$ ,  $v$ ,  $r$  and  $b$  only the damage should be considered, for the calculation of the  $s$ -value the flooded space should be considered. The figures below illustrate the difference.

Damage shown as the bold square:

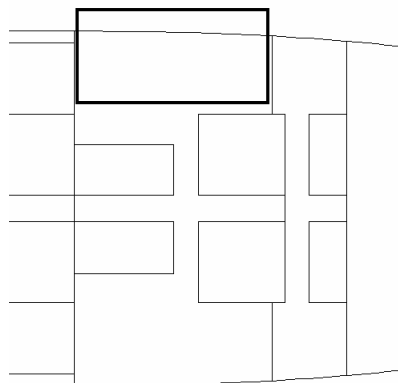

Flooded space shown below:

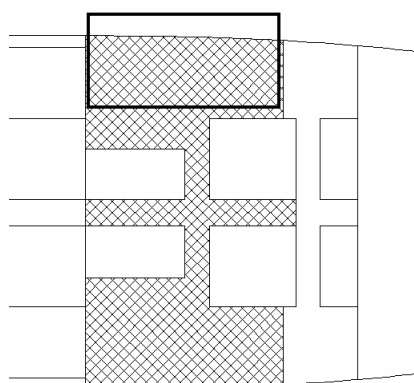

### Regulation 7-1.1.1

1 The coefficients  $b_{11}$ ,  $b_{12}$ ,  $b_{21}$  and  $b_{22}$  are coefficients in the bi-linear probability density function on normalized damage length ( $J$ ). The coefficient  $b_{12}$  is dependent on whether  $L_s$  is greater or less than  $L^*$  (i.e. 260 m); the other coefficients are valid irrespective of  $L_s$ .

#### *Longitudinal subdivision*

2 In order to prepare for the calculation of index  $A$ , the ship's subdivision length  $L_s$  is divided into a fixed discrete number of damage zones. These damage zones will determine the damage stability investigation in the way of specific damages to be calculated.

3 There are no rules for the subdividing, except that the length  $L_s$  defines the extremes for the actual hull. Zone boundaries need not coincide with physical watertight boundaries. However, it is important to consider a strategy carefully to obtain a good result (that is a large attained index  $A$ ). All zones and combination of adjacent zones may contribute to the index  $A$ . In general it is expected that the more zone boundaries the ship is divided into the higher will be the attained index, but this benefit must be balanced against extra computing time. The figure below shows different longitudinal zone divisions of the length  $L_s$ .

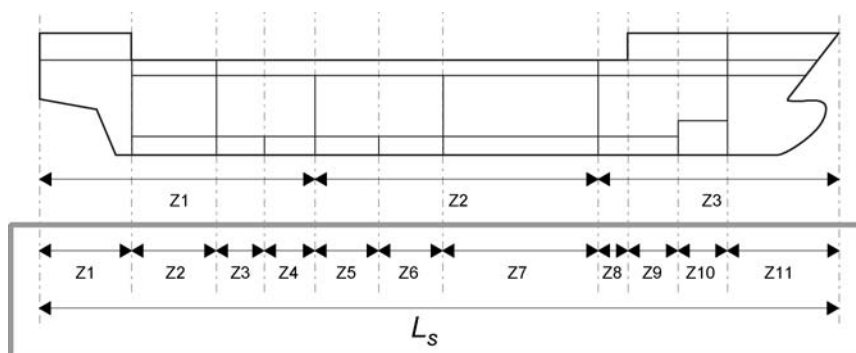

4 The first example is a very rough division into three zones of approximately the same size with limits where longitudinal subdivision is established. The probability that the ship will survive a damage in one of the three zones is expected to be low (i.e. the  $s$ -factor is low or zero) and, therefore, the total attained index  $A$  will be correspondingly low.



5 In the second example the zones have been placed in accordance with the watertight arrangement, including minor subdivision (as in double bottom, etc.). In this case there is a much better chance of obtaining higher  $s$ -factors.

6 Where transverse corrugated bulkheads are fitted, they may be treated as equivalent plane bulkheads, provided the corrugation depth is of the same order as the stiffening structure.

7 Pipes and valves directly adjacent to a transverse bulkhead can be considered to be part of the bulkhead, provided the separation distance is of the same order as the bulkhead stiffening structure. The same applies for small recesses, drain wells, etc.

8 For cases where the pipes and valves are outside the transverse bulkhead stiffening structure, when they present a risk of progressive flooding to other watertight compartments that will have influence on the overall attained index  $A$ , they should be handled either by introducing a new damage zone and accounting for the progressive flooding to associated compartments or by introducing a gap.

9 The triangle in the figure below illustrates the possible single and multiple zone damages in a ship with a watertight arrangement suitable for a seven-zone division. The triangles at the bottom line indicate single zone damages and the parallelograms indicate adjacent zones damages.

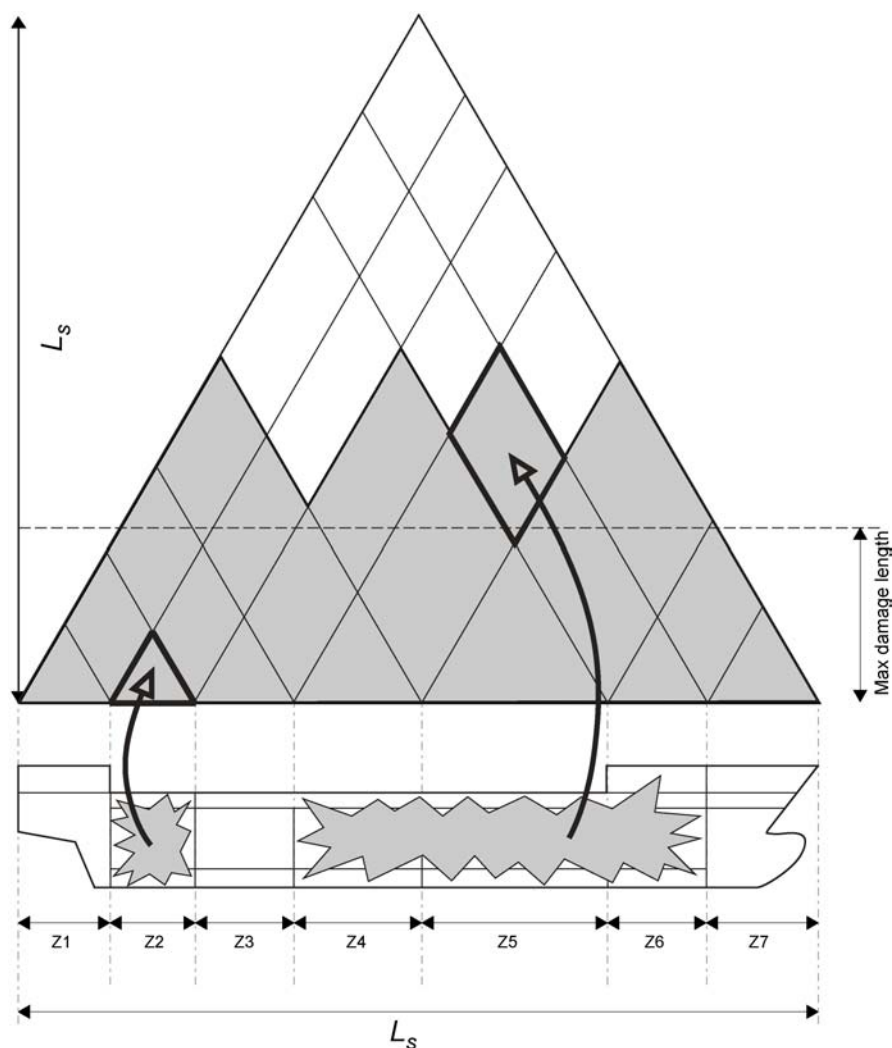

10 As an example, the triangle illustrates a damage opening the rooms in zone 2 to the sea and the parallelogram illustrates a damage where rooms in the zones 4, 5 and 6 are flooded simultaneously.

11 The shaded area illustrates the effect of the maximum absolute damage length. The  $p$ -factor for a combination of three or more adjacent zones equals zero if the length of the combined adjacent damage zones minus the length of the foremost and the aft most damage zones in the combined damage zone is greater than the maximum damage length. Having this in mind when subdividing  $L_s$  could limit the number of zones defined to maximize the attained index  $A$ .

12 As the  $p$ -factor is related to the watertight arrangement by the longitudinal limits of damage zones and the transverse distance from the ship side to any longitudinal barrier in the zone, the following indices are introduced:

$j$ : the damage zone number starting with No.1 at the stern;

$n$ : the number of adjacent damage zones in question where  $j$  is the aft zone;

$k$ : the number of a particular longitudinal bulkhead as a barrier for transverse penetration in a damage zone counted from shell towards the centreline. The shell has No.0;

$K$ : total number of transverse penetration boundaries;

$p_{j,n,k}$ : the  $p$ -factor for a damage in zone  $j$  and next  $(n-1)$  zones forward of  $j$  damaged to the longitudinal bulkhead  $k$ .

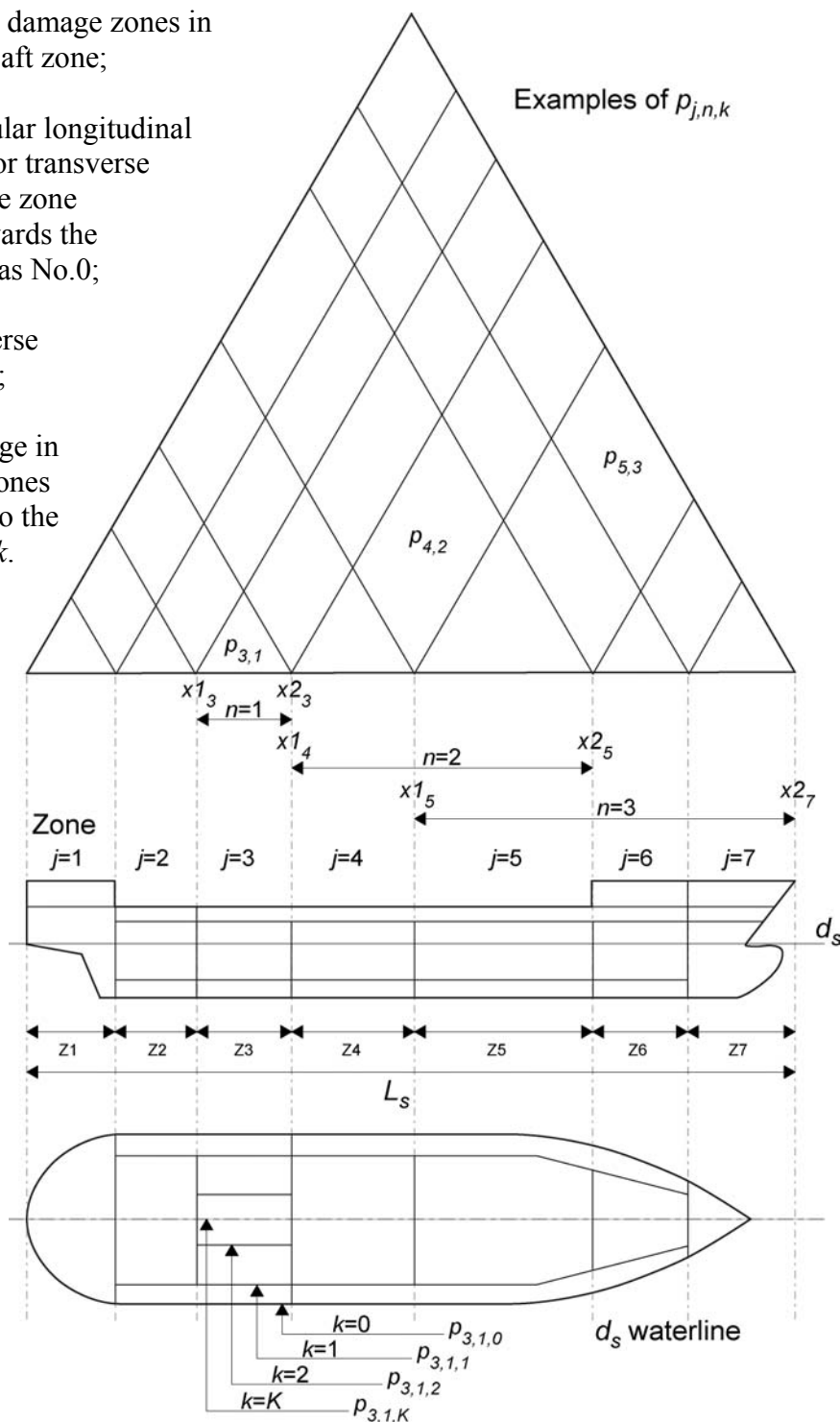

**Pure longitudinal subdivision**

Single damage zone, pure longitudinal subdivision:

$$p_{j,1} = p(x1_j, x2_j)$$

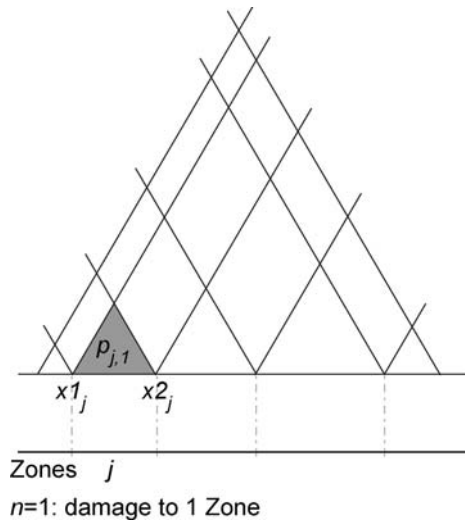

Two adjacent zones, pure longitudinal subdivision:

$$p_{j,2} = p(x1_j, x2_{j+1}) - p(x1_j, x2_j) - p(x1_{j+1}, x2_{j+1})$$

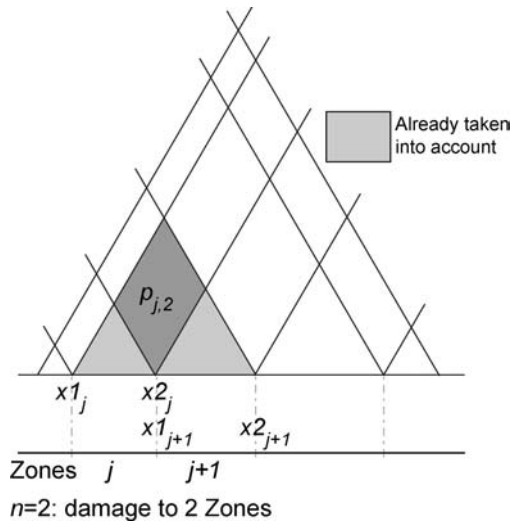

Three or more adjacent zones, pure longitudinal subdivision:

$$p_{j,n} = p(x1_j, x2_{j+n-1}) - p(x1_j, x2_{j+n-2}) - p(x1_{j+1}, x2_{j+n-1}) + p(x1_{j+1}, x2_{j+n-2})$$

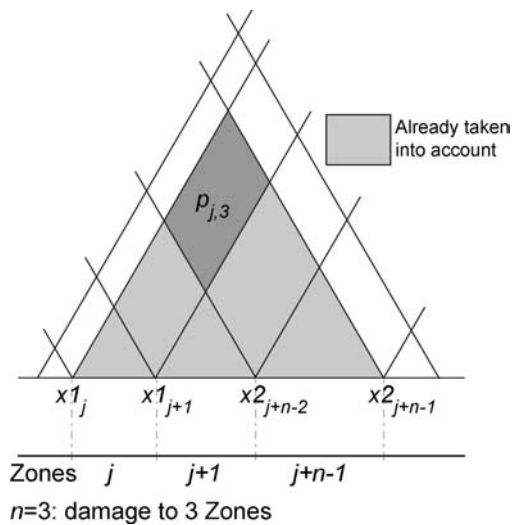

## Regulation 7-1.1.2

### *Transverse subdivision in a damage zone*

1 Damage to the hull in a specific damage zone may just penetrate the ship's watertight hull or penetrate further towards the centreline. To describe the probability of penetrating only a wing compartment, a probability factor  $r$  is used, based mainly on the penetration depth  $b$ . The value of  $r$  is equal to 1, if the penetration depth is  $B/2$  where  $B$  is the maximum breadth of the ship at the deepest subdivision draught  $d_s$ , and  $r = 0$  if  $b = 0$ .

2 The penetration depth  $b$  is measured at level deepest subdivision draught  $d_s$  as a transverse distance from the ship side right-angled to the centreline to a longitudinal barrier.

3 Where the actual watertight bulkhead is not a plane parallel to the shell,  $b$  should be determined by means of an assumed line, dividing the zone to the shell in a relationship  $b_1/b_2$  with  $1/2 \leq b_1/b_2 \leq 2$ .

4 Examples of such assumed division lines are illustrated in the figure below. Each sketch represents a single damage zone at a water line plane level  $d_s$  and the longitudinal bulkhead represents the outermost bulkhead position below  $d_s + 12.5$  m.

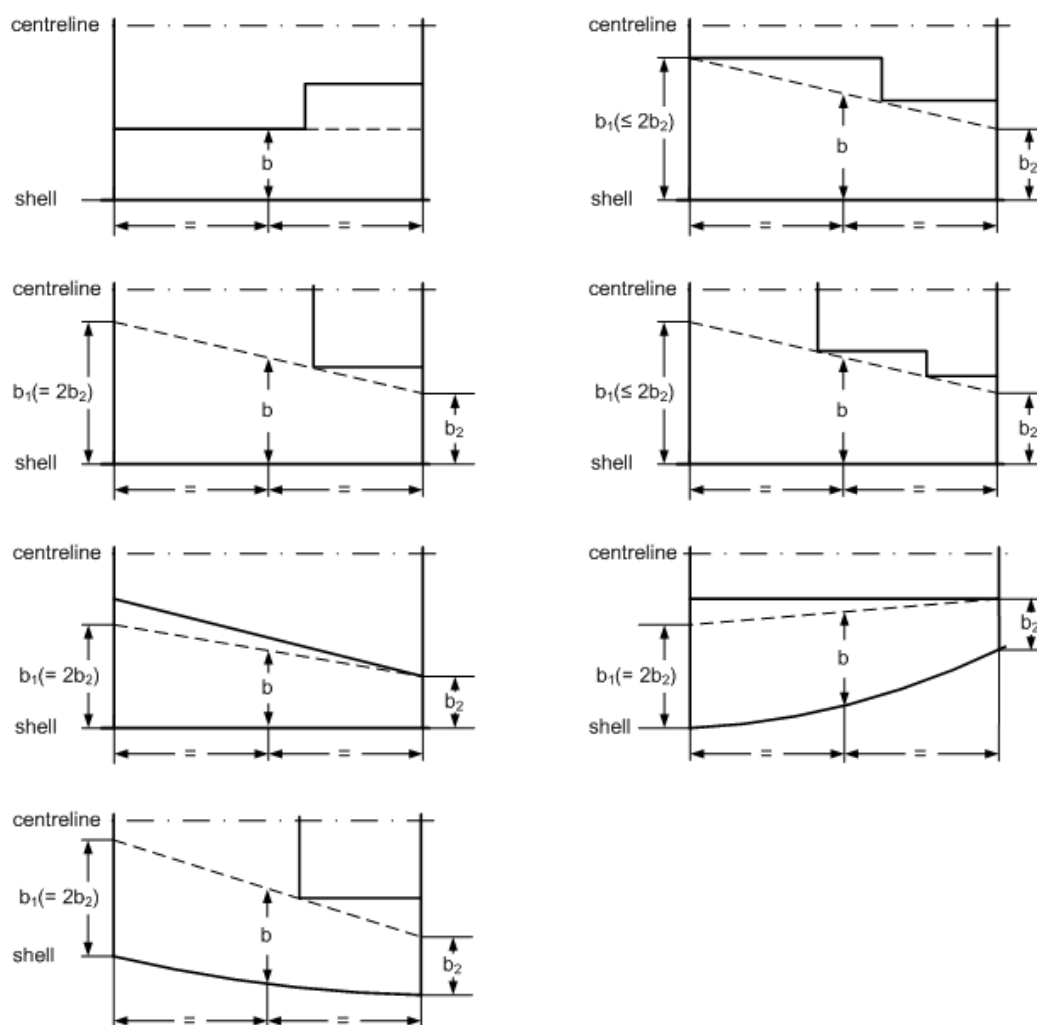

5 In calculating  $r$ -values for a group of two or more adjacent compartments, the  $b$ -value is common for all compartments in that group, and equal to the smallest  $b$ -value in that group:

$$b = \min\{b_1, b_2, \dots, b_n\}$$

where:  $n =$  number of wing compartments in that group;  
 $b_1, b_2, \dots, b_n =$  mean values of  $b$  for individual wing compartments contained in the group.

*Accumulating  $p$*

6 The accumulated value of  $p$  for one zone or a group of adjacent zones is determined by:

$$p_{j,n} = \sum_{k=1}^{K_{j,n}} p_{j,n,k}$$

where  $K_{j,n} = \sum_j^{j+n-1} K_j$  the total number of  $b_k$ 's for the adjacent zones in question.

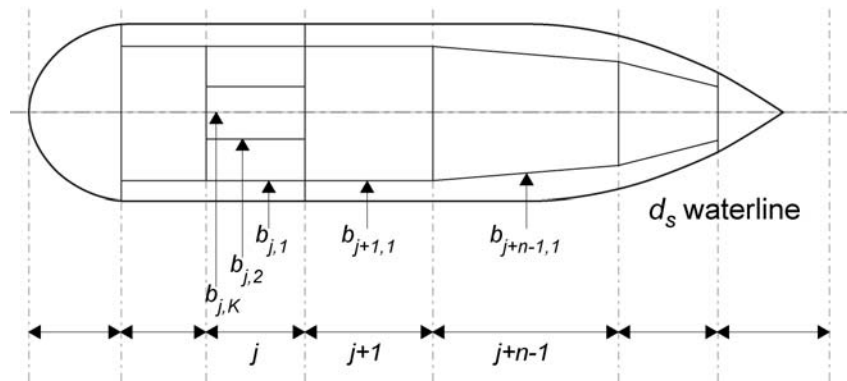

7 The figure above illustrates  $b$ 's for adjacent zones. The zone  $j$  has two penetration limits and one to the centre, the zone  $j+1$  has one  $b$  and the zone  $j+n-1$  has one value for  $b$ . The multiple zones will have  $(2+1+1)$  four values of  $b$ , and sorted in increasing order they are:

$$(b_{j,1}; b_{j+1,1}; b_{j+n-1,1}; b_{j,2}; b_K)$$

8 Because of the expression for  $r(x1, x2, b)$  only one  $b_K$  should be considered. To minimize the number of calculations,  $b$ 's of the same value may be deleted.

$$\text{As } b_{j,1} = b_{j+1,1} \text{ the final } b\text{'s will be } (b_{j,1}; b_{j+n-1,1}; b_{j,2}; b_K)$$

**Examples of multiple zones having a different  $b$**

9 Examples of combined damage zones and damage definitions are given in the figures below. Compartments are identified by R10, R12, etc.

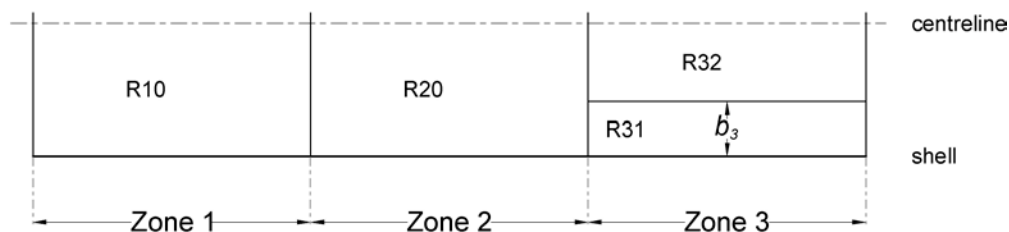

Figure: Combined damage of zones 1 + 2 + 3 includes a limited penetration to  $b_3$ , taken into account generating two damages:

- 1) to  $b_3$  with R10, R20 and R31 damaged;
- 2) to  $B/2$  with R10, R20, R31 and R32 damaged.

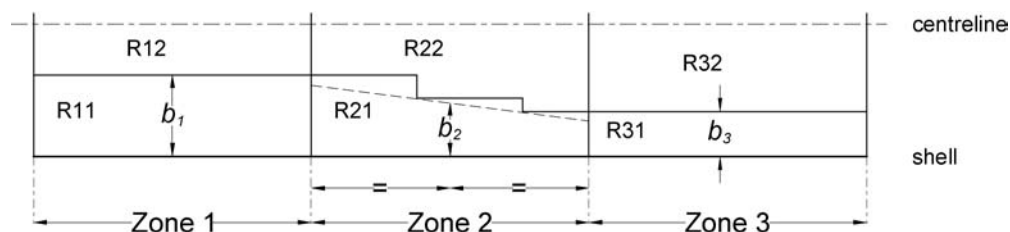

Figure: Combined damage of zones 1 + 2 + 3 includes 3 different limited damage penetrations generating four damages:

- 1) to  $b_3$  with R11, R21 and R31 damaged;
- 2) to  $b_2$  with R11, R21, R31 and R32 damaged;
- 3) to  $b_1$  with R11, R21, R31, R32, and R22 damaged;
- 4) to  $B/2$  with R11, R21, R31, R32, R22 and R12 damaged.

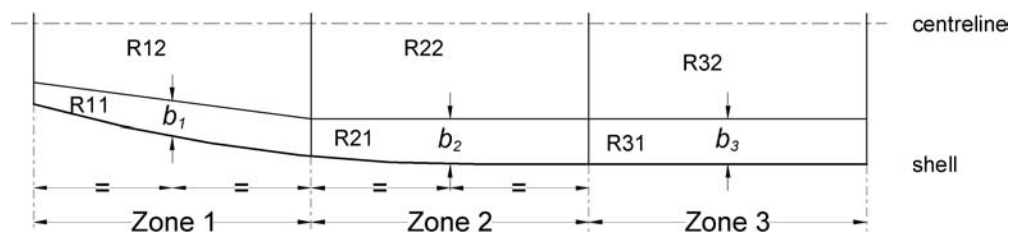
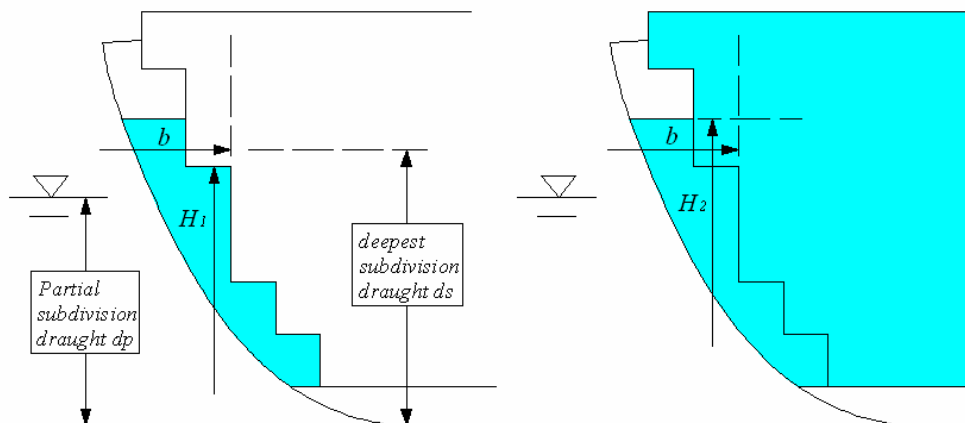

Figure: Combined damage of zone 1 + 2 + 3 including 2 different limited damage penetrations ( $b_1 < b_2 = b_3$ ) generating three damages:

- 1) to  $b_1$  with R11, R21 and R31 damaged;
- 2) to  $b_2$  with R11, R21, R31 and R12, damaged;
- 3) to  $B/2$  with R11, R21, R31, R12, R22 and R32 damaged.

10 A damage having a transverse extent  $b$  and a vertical extent  $H_2$  leads to the flooding of both wing compartment and hold; for  $b$  and  $H_1$  only the wing compartment is flooded. The figure below illustrates a partial subdivision draught  $d_p$  damage.



11 The same is valid if  $b$ -values are calculated for arrangements with sloped walls.

12 Pipes and valves directly adjacent to a longitudinal bulkhead can be considered to be part of the bulkhead, provided the separation distance is of the same order as the bulkhead stiffening structure. The same applies for small recesses, drain wells, etc.

## REGULATION 7-2 – CALCULATION OF THE FACTOR $s_i$

### General

1 Initial condition – an intact loading condition to be considered in the damage analysis described by the mean draught, vertical centre of gravity and the trim; or alternative parameters from where the same may be determined (ex. displacement,  $GM$  and trim). There are three initial conditions corresponding to the three draughts  $d_s$ ,  $d_p$  and  $d_l$ .

2 Immersion limits – immersion limits are an array of points that are not to be immersed at various stages of flooding as indicated in regulations 7-2.5.2 and 7-2.5.3.

3 Openings – all openings need to be defined: both weathertight and unprotected. Openings are the most critical factor to preventing an inaccurate index  $A$ . If the final waterline immerses the lower edge of any opening through which progressive flooding takes place, the factor “ $s$ ” may be recalculated taking such flooding into account. However, in this case the  $s$  value should also be calculated without taking into account progressive flooding and corresponding opening. The smallest  $s$  value should be retained for the contribution to the attained index.

### Regulation 7-2.1

1 In cases where the  $GZ$  curve may include more than one “range” of positive righting levers for a specific stage of flooding, only one continuous positive “range” of the  $GZ$  curve may be used within the allowable range/heel limits for calculation purposes. Different stages of flooding may not be combined in a single  $GZ$  curve.



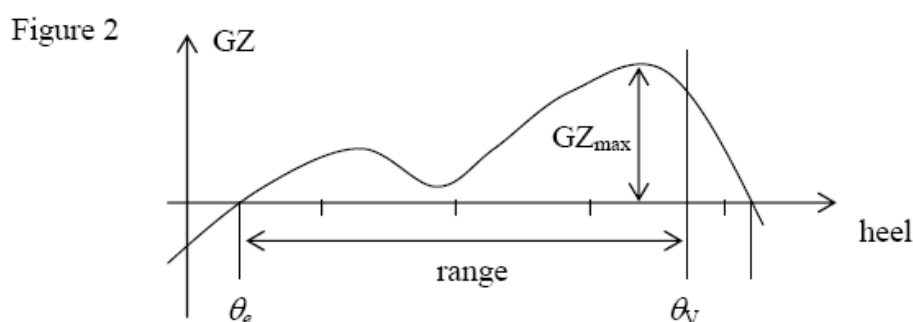
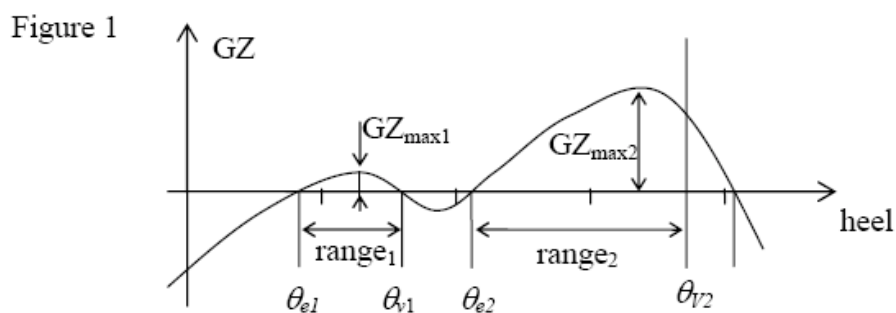

2 In figure 1, the  $s$ -factor may be calculated from the heel angle, range and corresponding  $GZ_{max}$  of the first or second “range” of positive righting levers. In figure 2, only one  $s$ -factor can be calculated.

## Regulation 7-2.2

### *Intermediate stages of flooding*

1 The case of instantaneous flooding in unrestricted spaces in way of the damage zone does not require intermediate stage flooding calculations. Where intermediate stages of flooding calculations are necessary in connection with progressive flooding, they should reflect the sequence of filling as well as filling level phases. Calculations for intermediate stages of flooding should be performed whenever equalization is not instantaneous, i.e. equalization is of a duration greater than 60 s. Such calculations consider the progress through one or more floodable (non-watertight) spaces. Bulkheads surrounding refrigerated spaces, incinerator rooms and longitudinal bulkheads fitted with non-watertight doors are typical examples of structures that may significantly slow down the equalization of main compartments.

### *Flooding boundaries*

2 If a compartment contains decks, inner bulkheads, structural elements and doors of sufficient tightness and strength to seriously restrict the flow of water, for intermediate stage flooding calculation purposes it should be divided into corresponding non-watertight spaces. It is assumed that the non-watertight divisions considered in the calculations are limited to “A” class fire-rated bulkheads and do not apply to “B” class fire-rated bulkheads normally used in accommodation areas (e.g., cabins and corridors). This guidance also relates to regulation 4.4.

### ***Sequential flooding computation***

3 For each damage scenario, the damage extent and location determine the initial stage of flooding. Calculations should be performed in stages, each stage comprising of at least two intermediate filling phases in addition to the full phase per flooded space. Unrestricted spaces in way of damage should be considered as flooded immediately. Every subsequent stage involves all connected spaces being flooded simultaneously until an impermeable boundary or final equilibrium is reached. If due to the configuration of the subdivision in the ship it is expected that other intermediate stages of flooding are more onerous, then those should be investigated.

### ***Cross-flooding/equalization***

4 In general, cross-flooding is meant as a flooding of an undamaged space on the other side of the ship to reduce the heel in the final equilibrium condition.

5 The cross-flooding time should be calculated in accordance with resolution MSC.245(83) (Recommendation on a standard method for evaluating cross-flooding arrangements). If complete fluid equalization occurs in 60 s or less, it should be treated as instantaneous and no further calculations need to be carried out. Additionally, in cases where  $s_{final} = 1$  is achieved in 60 s or less, but equalization is not complete, instantaneous flooding may also be assumed if  $s_{final}$  will not become reduced. In any cases where complete fluid equalization exceeds 60 s, the value of  $s_{intermediate}$  after 60 s is the first intermediate stage to be considered. Only passive open cross-flooding arrangements without valves should be considered effective for instantaneous flooding cases.

6 If complete fluid equalization can be finalized in 10 min or less, the assessment of survivability can be carried out for passenger ships as the smallest values of  $s_{intermediate}$  or  $s_{final}$ .

7 In case the equalization time is longer than 10 min,  $s_{final}$  is calculated for the floating position achieved after 10 min of equalization. This floating position is computed by calculating the amount of flood water according to resolution MSC.245(83) using interpolation, where the equalization time is set to 10 min, i.e. the interpolation of the flood water volume is made between the case before equalization ( $T = 0$ ) and the total calculated equalization time.

8 In any cases where complete fluid equalization exceeds 10 min, the value of  $s_{final}$  used in the formula in regulation 7-2.1.1 should be the minimum of  $s_{final}$  at 10 min or at final equalization.

### ***Cargo ships***

9 If the Administration considers that the stability in intermediate stages of flooding in a cargo ship may be insufficient, it may require further investigation thereof.

### **Regulation 7-2.4**

The displacement is the intact displacement at the subdivision draught in question ( $d_s$ ,  $d_p$  and  $d_i$ ).

#### **Regulation 7-2.4.1.1**

The beam  $B$  used in this paragraph means breadth as defined in regulation 2.8.

### **Regulation 7-2.4.1.2**

The parameter  $A$  (projected lateral area) used in this paragraph does not refer to the attained subdivision index.

### **Regulation 7-2.5**

In cargo ships where cross-flooding devices are fitted, the safety of the ship should be maintained in all stages of flooding. The Administration may request for this to be demonstrated. Cross-flooding equipment, if installed, should have the capacity to ensure that the equalization takes place within 10 min.

#### **Regulation 7-2.5.2.1**

##### ***Unprotected openings***

1 The flooding angle will be limited by immersion of such an opening. It is not necessary to define a criterion for non-immersion of unprotected openings at equilibrium, because if it is immersed, the range of positive  $GZ$  limited to flooding angle will be zero so “ $s$ ” will be equal to zero.

2 An unprotected opening connects two rooms or one room and the outside. An unprotected opening will not be taken into account if the two connected rooms are flooded or none of these rooms are flooded. If the opening is connected to the outside, it will not be taken into account if the connected compartment is flooded. An unprotected opening does not need to be taken into account if it connects a flooded room or the outside to an undamaged room, if this room will be considered as flooded in a subsequent stage.

##### ***Openings fitted with a weathertight mean of closing (“weathertight openings”)***

3 The survival “ $s$ ” factor will be “0” if any such point is submerged at a stage which is considered as “final”. Such points may be submerged during a stage or phase which is considered as “intermediate”, or within the range beyond equilibrium.

4 If an opening fitted with a weathertight means of closure is submerged at equilibrium during a stage considered as intermediate, it should be demonstrated that this weathertight means of closure can sustain the corresponding head of water and that the leakage rate is negligible.

5 These points are also defined as connecting two rooms or one room and the outside, and the same principle as for unprotected openings is applied to take them into account or not. If several stages have to be considered as “final”, a “weathertight opening” does not need to be taken into account if it connects a flooded room or the outside to an undamaged room if this room will be considered as flooded in a successive “final” stage.

#### **Regulation 7-2.5.2.2**

1 Partial immersion of the bulkhead deck may be accepted at final equilibrium. This provision is intended to ensure that evacuation along the bulkhead deck to the vertical escapes will not be impeded by water on that deck. A “horizontal evacuation route” in the context of this regulation means a route on the bulkhead deck connecting spaces located on and under this deck with the vertical escapes from the bulkhead deck required for compliance with SOLAS chapter II-2.

2 Horizontal evacuation routes on the bulkhead deck include only escape routes (designated as category 2 stairway spaces according to SOLAS regulation II-2/9.2.2.3 or as category 4 stairway spaces according to SOLAS regulation II-2/9.2.2.4 for passenger ships carrying not more than 36 passengers) used for the evacuation of undamaged spaces. Horizontal evacuation routes do not include corridors (designated as category 3 corridor spaces according to SOLAS regulation II-2/9.2.2.3 or as category 2 corridor spaces according to SOLAS regulation II-2/9.2.2.4 for passenger ships carrying not more than 36 passengers) within the damaged space. No part of a horizontal evacuation route serving undamaged spaces should be immersed.

3  $s_i = 0$  where it is not possible to access a stair leading up to the embarkation deck from an undamaged space as a result of flooding to the “stairway” or “horizontal stairway” on the bulkhead deck.

4 Horizontal escapes situated in way of the damage extent may remain effective, therefore  $s_i$  need not be taken as zero. Contributions to the attained index  $A$  may still be gained.

### Regulation 7-2.5.3.1

1 The purpose of this paragraph is to provide an incentive to ensure that evacuation through a vertical escape will not be obstructed by water from above. The paragraph is intended for smaller emergency escapes, typically hatches, where fitting of a watertight or weathertight means of closure would otherwise exclude them from being considered as flooding points.

2 Since the probabilistic regulations do not require that the watertight bulkheads be carried continuously up to the bulkhead deck, care should be taken to ensure that evacuation from intact spaces through flooded spaces below the bulkhead deck will remain possible, for instance by means of a watertight trunk.

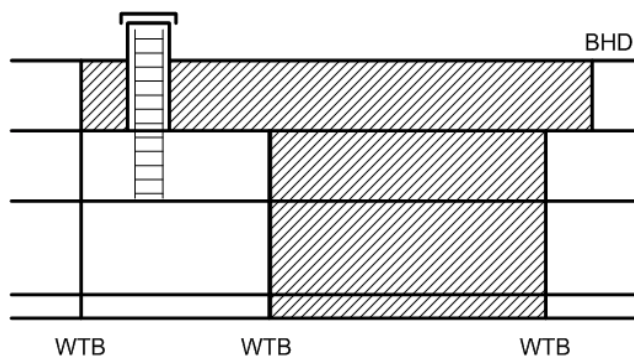

### Regulation 7-2.6

The sketches in the figure illustrate the connection between position of watertight decks in the reserve buoyancy area and the use of factor  $v$  for damages below these decks.

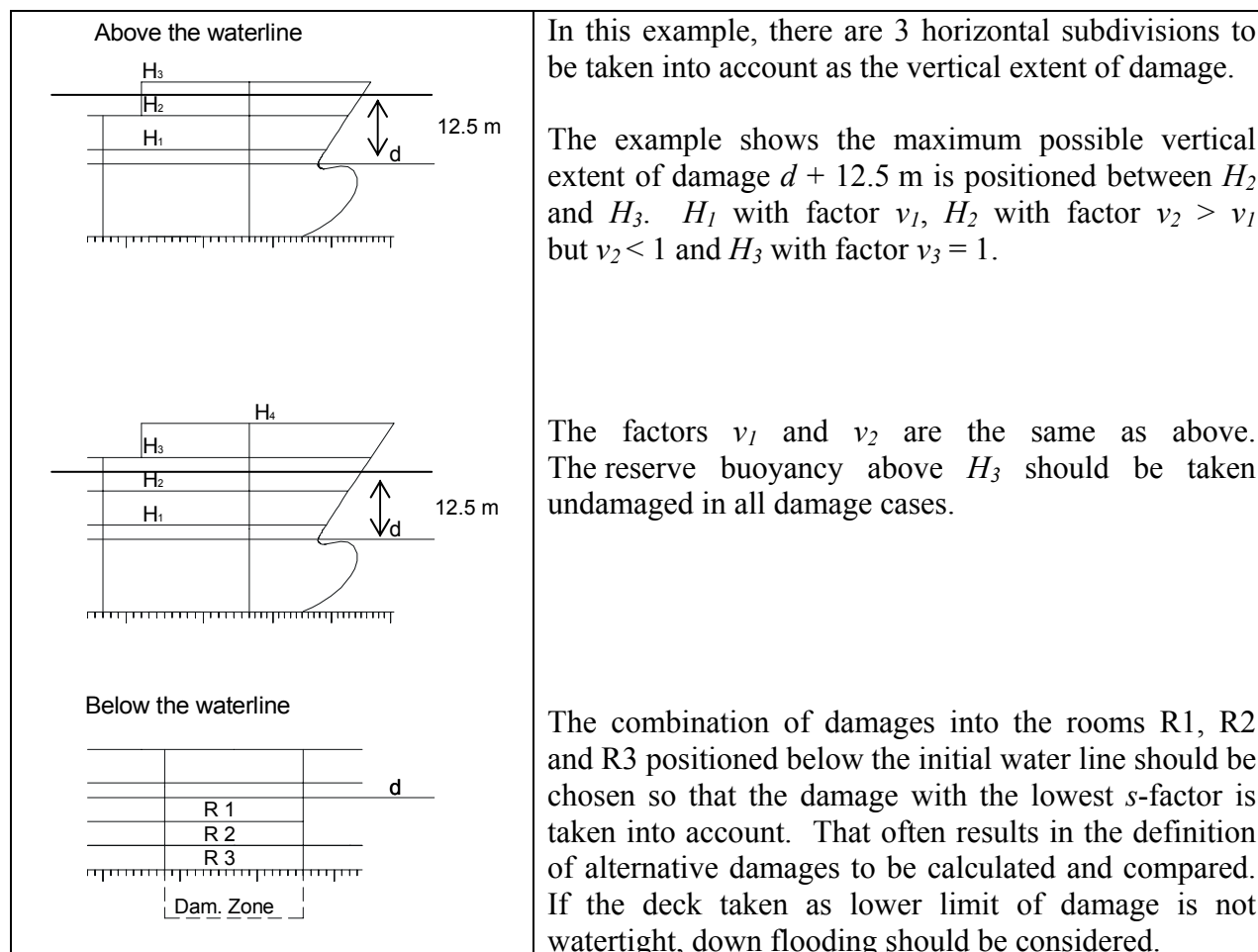

#### Regulation 7-2.6.1

The parameters  $x_1$  and  $x_2$  are the same as parameters  $x1$  and  $x2$  used in regulation 7-1.

## REGULATION 7-3 – PERMEABILITY

### Regulation 7-3.2

1 The following additional cargo permeabilities may be used:

Spaces	Permeability at draught $d_s$	Permeability at draught $d_p$	Permeability at draught $d_l$
Timber cargo in holds	0.35	0.70	0.95
Wood chip cargo	0.60	0.70	0.95

2 Reference is made to MSC/Circ.998 (IACS Unified Interpretation regarding timber deck cargo in the context of damage stability requirements) regarding timber deck cargo.

### Regulation 7-3.3

1 Concerning the use of other figures for permeability “if substantiated by calculations”, such permeabilities should reflect the general conditions of the ship throughout its service life rather than specific loading conditions.

2 This paragraph allows for the recalculation of permeabilities. This should only be considered in cases where it is evident that there is a major discrepancy between the values shown in the regulation and the real values. It is not designed for improving the attained value of a deficient ship of regular type by the modification of chosen spaces in the ship that are known to provide significantly onerous results. All proposals should be considered on a case-by-case basis by the Administration and should be justified with adequate calculations and arguments.

## REGULATION 8 – SPECIAL REQUIREMENTS CONCERNING PASSENGER SHIP STABILITY

### Regulations 8.3.2 to 8.3.5

The number of persons carried, which is specified in these paragraphs, equals the total number of persons the ship is permitted to carry (and not  $N = N_1 + 2 N_2$  as defined in regulation 6).

## REGULATION 8-1 – SYSTEM CAPABILITIES AFTER A FLOODING CASUALTY ON PASSENGER SHIPS

### Regulation 8-1.2

1 In the context of this regulation, “compartment” has the same meaning as defined under regulation 7-1 of these Explanatory Notes (i.e. an onboard space within watertight boundaries).

2 The purpose of the paragraph is to prevent any flooding of limited extent from immobilizing the ship. This principle should be applied regardless of how the flooding might occur. Only flooding below the bulkhead deck need be considered.

## REGULATION 9 – DOUBLE BOTTOMS IN PASSENGER SHIPS AND CARGO SHIPS OTHER THAN TANKERS

### Regulation 9.1

1 This regulation is intended to minimize the impact of flooding from a minor grounding. Special attention should be paid to the vulnerable area at the turn of the bilge. When justifying a deviation from fitting an inner bottom an assessment of the consequences of allowing a more extensive flooding than reflected in the regulation should be provided.

2 Except as provided in regulations 9.3 and 9.4, parts of the double bottom not extended for the full width of the ship as required by regulation 9.1 should be considered an unusual arrangement for the purpose of this regulation and is to be handled in accordance with regulation 9.7

### Regulation 9.2

If an inner bottom is located higher than the partial subdivision draught  $d_p$ , this should be considered an unusual arrangement and is to be handled in accordance with regulation 9.7.

### Regulation 9.6

1 Any part of a passenger ship or a cargo ship where a double bottom is omitted in accordance with regulation 9.1, 9.4 or 9.5 shall be capable of withstanding bottom damages, as specified in regulation 9.8. The intent of this provision is to specify the circumstances under which the Administration should require calculations, which damage extents to assume and what survival criteria to apply when double bottoms are not fitted.

2 The definition of “watertight” in regulation 2.17 implies that the strength of inner bottoms and other boundaries assumed to be watertight must be verified if they are to be considered effective in this context.

### Regulation 9.7

The reference to a “plane” in regulation 9.2 does not imply that the surface of the inner bottom may not be stepped in the vertical direction. Minor steps and recesses need not be considered unusual arrangements for the purpose of this paragraph as long as no part of the inner bottom is located below the reference plane. Discontinuities in way of wing tanks are covered by regulation 9.4.

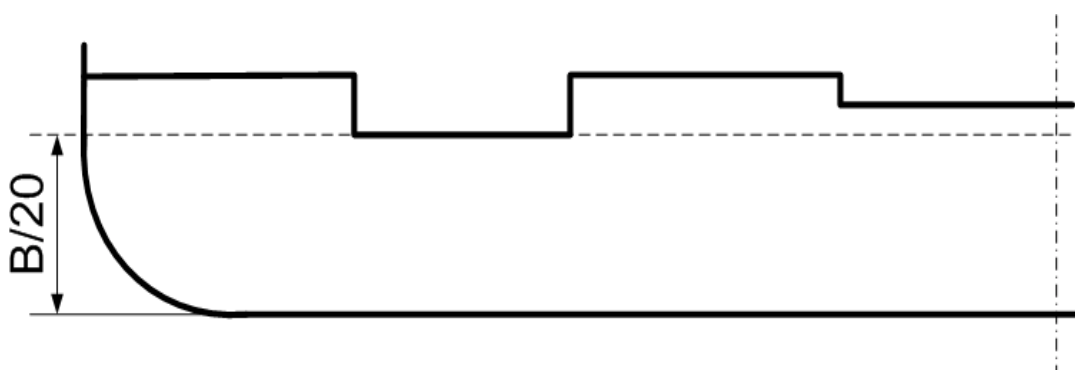

### Regulation 9.8

1 The term “all service conditions” used in this paragraph means the three loading conditions used to calculate the attained subdivision index *A*.

2 The damage extents specified in this paragraph should be applied to all parts of the ship where no double bottom is fitted, as permitted by regulations 9.1, 9.4 or 9.5, and include any adjacent spaces located within the extent of damage. Small wells in accordance with regulation 9.3 do not need to be considered damaged even if within the extent of the damage. Possible positions of the damages are shown in an example below (parts of the ship not fitted with a double bottom are shaded; the damages to be assumed are indicated by boxes).

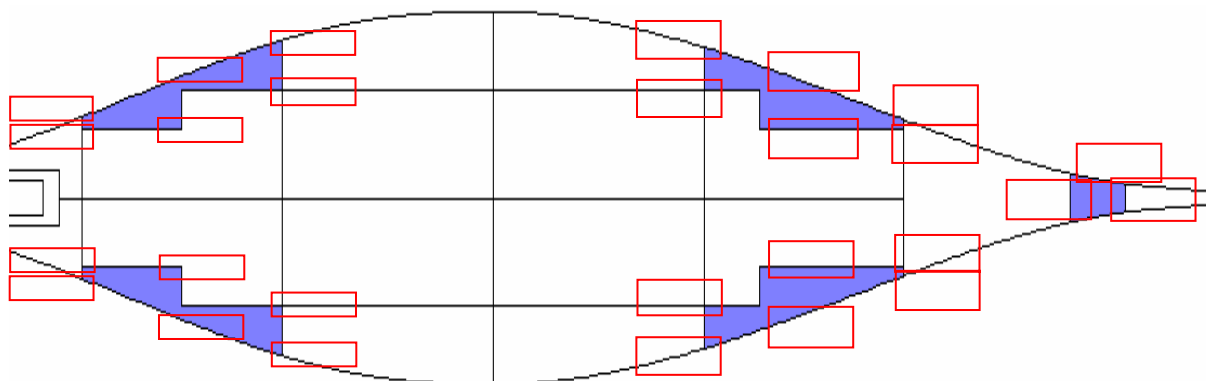

### Regulation 9.9

1 For the purpose of identifying “large lower holds”, horizontal surfaces having a continuous deck area greater than approximately 30% in comparison with the waterplane area at subdivision draught should be taken to be located anywhere in the affected area of the ship. For the alternative bottom damage calculation, a vertical extent of  $B/10$  or 3 m, whichever is less, should be assumed.

2 The increased minimum double bottom height of not more than  $B/10$  or 3 m, whichever is less, for passenger ships with large lower holds, is applicable to holds in direct contact with the double bottom. Typical arrangements of ro-ro passenger ships may include a large lower hold with additional tanks between the double bottom and the lower hold, as shown in the figure below. In such cases, the vertical position of the double bottom required to be  $B/10$  or 3 m, whichever is less, should be applied to the lower hold deck, maintaining the required double bottom height of  $B/20$  or 2 m, whichever is less (but not less than 760 mm). The figure below shows a typical arrangement of a modern ro-ro passenger ferry.



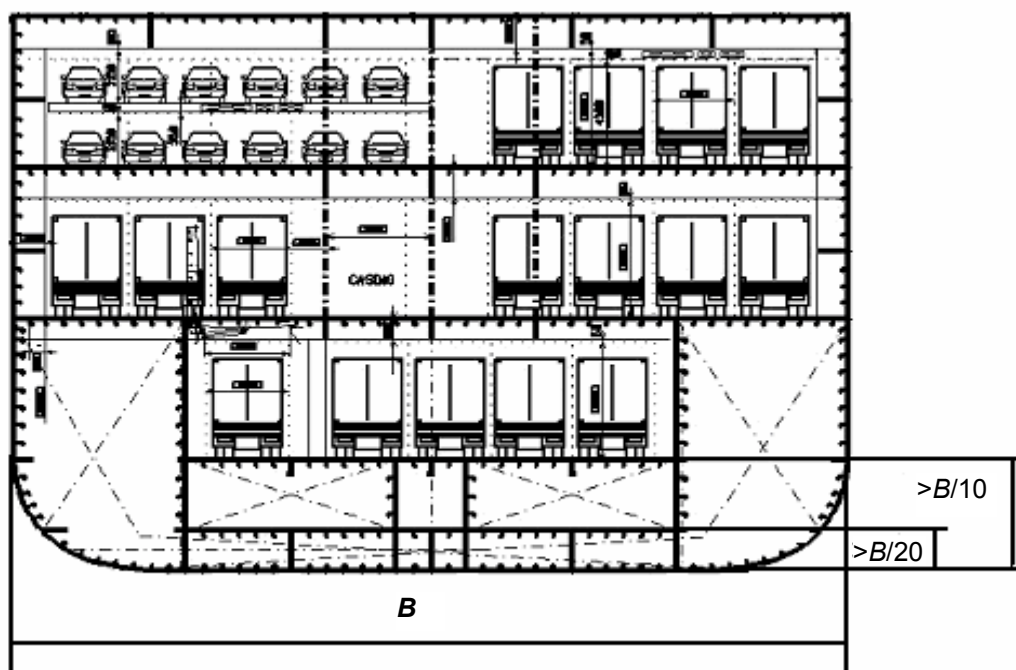

## REGULATION 10 – CONSTRUCTION OF WATERTIGHT BULKHEADS

### Regulation 10.1

For the treatment of steps in the bulkhead deck of passenger ships see Explanatory Notes for regulation 13. For the treatment of steps in the freeboard deck of cargo ships see Explanatory Notes for regulation 13-1.

## REGULATION 12 – PEAK AND MACHINERY SPACE BULKHEADS, SHAFT TUNNELS, ETC.

Reference is made to MSC.1/Circ.1211 (Unified interpretations to SOLAS regulation II-1/10 and regulation 12 of the revised SOLAS chapter II-1 regarding bow doors and the extension of the collision bulkhead) concerning interpretations regarding bow doors and the extension of the collision bulkhead.

## REGULATION 13 – OPENINGS IN WATERTIGHT BULKHEADS BELOW THE BULKHEAD DECK IN PASSENGER SHIPS

### General – Steps in the bulkhead deck

1 If the transverse watertight bulkheads in a region of the ship are carried to a higher deck which forms a vertical step in the bulkhead deck, openings located in the bulkhead at the step may be considered as being located above the bulkhead deck. Such openings should then comply with regulation 17 and should be taken into account when applying regulation 7-2.

2 All openings in the shell plating below the upper deck throughout that region of the ship should be treated as being below the bulkhead deck and the provisions of regulation 15 should be applied. See figure below.

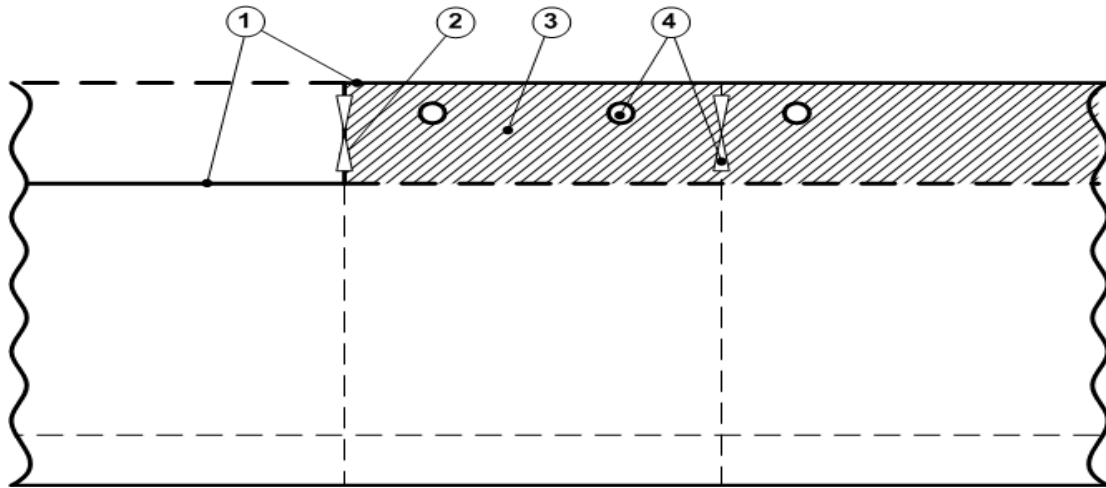

- |                 |   |
|-----------------|---|
| 1 Bulkhead deck | 2 Considered as located above the bulkhead deck |
| 3 Ship's side   | 4 Considered as located below the bulkhead deck |

#### Regulation 13.4

In cases where main and auxiliary propulsion machinery spaces, including boilers serving the needs for propulsion, are divided by watertight longitudinal bulkheads in order to comply with redundancy requirements (e.g., according to regulation 8-1.2), one watertight door in each watertight bulkhead may be permitted, as shown in the figure below.

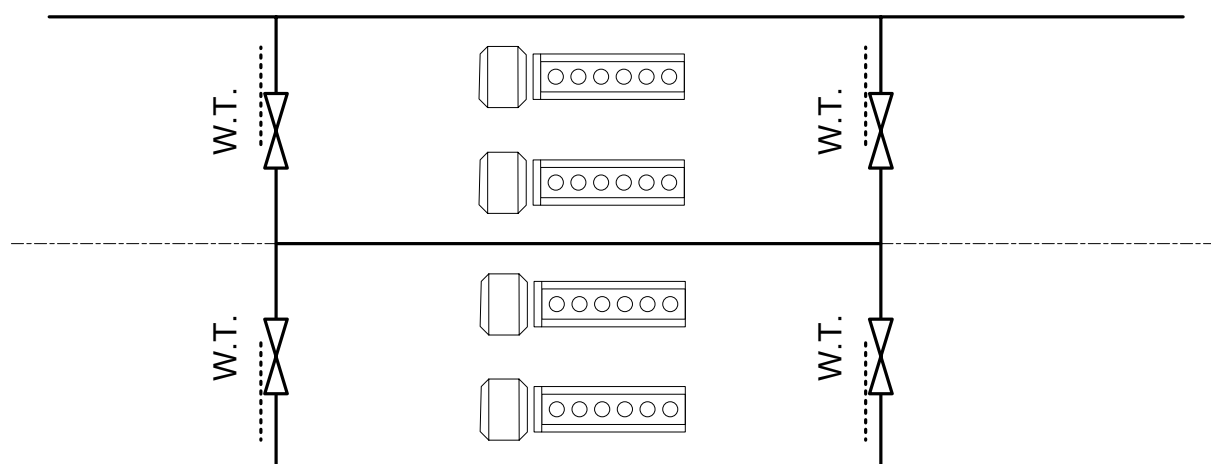

#### Regulation 13.7.6

The IEC standard referenced in the footnote (IEC publication 529, 1976) has been replaced by the newer standard IEC 60529:2003.

### REGULATION 13-1 – OPENINGS IN WATERTIGHT BULKHEADS AND INTERNAL DECKS IN CARGO SHIPS

#### Regulation 13-1.1

1 If the transverse watertight bulkheads in a region of the ship are carried to a higher deck than in the remainder of the ship, openings located in the bulkhead at the step may be considered as being located above the freeboard deck.

2 All openings in the shell plating below the upper deck throughout that region of the ship should be treated as being below the freeboard deck, similar to the bulkhead deck for passenger ships (see relevant figure under regulation 13 above), and the provisions of regulation 15 should be applied.

## **REGULATION 15 – OPENINGS IN THE SHELL PLATING BELOW THE BULKHEAD DECK OF PASSENGER SHIPS AND THE FREEBOARD DECK OF CARGO SHIPS**

### **General – Steps in the bulkhead deck and freeboard deck**

For the treatment of steps in the bulkhead deck of passenger ships see Explanatory Notes for regulation 13. For the treatment of steps in the freeboard deck of cargo ships see Explanatory Notes for regulation 13-1.

## **REGULATION 15-1 – EXTERNAL OPENINGS IN CARGO SHIPS**

### **Regulation 15-1.1**

With regard to air-pipe closing devices, they should be considered weathertight closing devices (not watertight). This is consistent with their treatment in regulation 7-2.5.2.1. However, in the context of regulation 15-1, “external openings” are not intended to include air-pipe openings.

## **REGULATION 16 – CONSTRUCTION AND INITIAL TESTS OF WATERTIGHT DOORS, SIDESCUTTLES, ETC.**

### **Regulation 16.2**

1 Watertight doors should be tested by water pressure to a head of water measured from the lower edge of the door opening to the bulkhead deck or the freeboard deck, or to the most unfavourable final or intermediate waterplane during flooding, whichever is greater.

2 Large doors, hatches or ramps on passenger and cargo ships, of a design and size that would make pressure testing impracticable, may be exempted from regulation 16.2, provided it is demonstrated by calculations that the doors, hatches or ramps maintain watertightness at design pressure with a proper margin of resistance. Where such doors utilize gasket seals, a prototype pressure test to confirm that the compression of the gasket material is capable of accommodating any deflection, revealed by the structural analysis, should be carried out. After installation every such door, hatch or ramp should be tested by means of a hose test or equivalent.

*Note:* See Explanatory Notes for regulation 13 for additional information regarding the treatment of steps in the bulkhead deck of passenger ships. See Explanatory Notes for regulation 13-1 for additional information regarding the treatment of steps in the freeboard deck of cargo ships.

## **REGULATION 17 – INTERNAL WATERTIGHT INTEGRITY OF PASSENGER SHIPS ABOVE THE BULKHEAD DECK**

### **General – Steps in the bulkhead deck**

For the treatment of steps in the bulkhead deck of passenger ships see Explanatory Notes for regulation 13.

### **Regulation 17.1**

Watertight sliding doors with reduced pressure head complying with the requirements of MSC/Circ.541, as may be amended, should be in line with regulation 7-2.5.2.1. These types of tested watertight sliding doors with reduced pressure head could be immersed during intermediate stages of flooding.

### **Regulation 17.3**

These provisions regarding the open end of air pipes should be applied only to damages of longitudinal and transverse extent as defined in regulation 8.3 but limited to the bulkhead deck and involving tanks having their open end terminating within the superstructure.

## APPENDIX

### GUIDELINES FOR THE PREPARATION OF SUBDIVISION AND DAMAGE STABILITY CALCULATIONS

#### 1 GENERAL

##### 1.1 Purpose of the Guidelines

1.1.1 These Guidelines serve the purpose of simplifying the process of the damage stability analysis, as experience has shown that a systematic and complete presentation of the particulars results in considerable saving of time during the approval process.

1.1.2 A damage stability analysis serves the purpose to provide proof of the damage stability standard required for the respective ship type. At present, two different calculation methods, the deterministic concept and the probabilistic concept are applied.

##### 1.2 Scope of analysis and documentation on board

1.2.1 The scope of subdivision and damage stability analysis is determined by the required damage stability standard and aims at providing the ship's master with clear intact stability requirements. In general, this is achieved by determining *KG*-respective *GM*-limit curves, containing the admissible stability values for the draught range to be covered.

1.2.2 Within the scope of the analysis thus defined, all potential or necessary damage conditions will be determined, taking into account the damage stability criteria, in order to obtain the required damage stability standard. Depending on the type and size of ship, this may involve a considerable amount of analyses.

1.2.3 Referring to SOLAS chapter II-1, regulation 19, the necessity to provide the crew with the relevant information regarding the subdivision of the ship is expressed, therefore plans should be provided and permanently exhibited for the guidance of the officer in charge. These plans should clearly show for each deck and hold the boundaries of the watertight compartments, the openings therein with means of closure and position of any controls thereof, and the arrangements for the correction of any list due to flooding. In addition, Damage Control Booklets containing the aforementioned information should be available.

#### 2 DOCUMENTS FOR SUBMISSION

##### 2.1 Presentation of documents

The documentation should begin with the following details: principal dimensions, ship type, designation of intact conditions, designation of damage conditions and pertinent damaged compartments, *KG*-respective *GM*-limit curve.

## 2.2 General documents

For the checking of the input data, the following should be submitted:

- .1 main dimensions;
- .2 lines plan, plotted or numerically;
- .3 hydrostatic data and cross curves of stability (including drawing of the buoyant hull);
- .4 definition of sub-compartments with moulded volumes, centres of gravity and permeability;
- .5 layout plan (watertight integrity plan) for the sub-compartments with all internal and external opening points including their connected sub-compartments, and particulars used in measuring the spaces, such as general arrangement plan and tank plan. The subdivision limits, longitudinal, transverse and vertical, should be included;
- .6 light service condition;
- .7 load line draught;
- .8 coordinates of opening points with their level of tightness (e.g., weathertight, unprotected);
- .9 watertight door location with pressure calculation;
- .10 side contour and wind profile;
- .11 cross and down flooding devices and the calculations thereof according to resolution MSC.245(83) with information about diameter, valves, pipe lengths and coordinates of inlet/outlet;
- .12 pipes in damaged area when the destruction of these pipes results in progressive flooding; and
- .13 damage extensions and definition of damage cases.

## 2.3 Special documents

The following documentation of results should be submitted.

### 2.3.1 Documentation

#### 2.3.1.1 Initial data:

- .1 subdivision length  $L_s$ ;

- .2 initial draughts and the corresponding  $GM$ -values;
- .3 required subdivision index  $R$ ; and
- .4 attained subdivision index  $A$  with a summary table for all contributions for all damaged zones.

2.3.1.2 Results for each damage case which contributes to the index  $A$ :

- .1 draught, trim, heel,  $GM$  in damaged condition;
- .2 dimension of the damage with probabilistic values  $p$ ,  $v$  and  $r$ ;
- .3 righting lever curve (including  $GZ_{max}$  and range) with factor of survivability  $s$ ;
- .4 critical weathertight and unprotected openings with their angle of immersion; and
- .5 details of sub-compartments with amount of in-flooded water/lost buoyancy with their centres of gravity.

2.3.1.3 In addition to the requirements in paragraph 2.3.1.2, particulars of non-contributing damages ( $s_i = 0$  and  $p_i > 0.00$ ) should also be submitted for passenger ships and ro-ro ships fitted with long lower holds including full details of the calculated factors.

### 2.3.2 Special consideration

For intermediate conditions, as stages before cross-flooding or before progressive flooding, an appropriate scope of the documentation covering the aforementioned items is needed in addition.

\*\*\*



**ANNEX 2****DRAFT MSC CIRCULAR****GUIDELINES FOR FLOODING DETECTION SYSTEMS ON PASSENGER SHIPS**

1 The Maritime Safety Committee, at its [eighty-fifth session (26 November to 5 December 2008)], approved the Guidelines for flooding detection systems on passenger ships, set out in the annex, following the recommendations made by the Sub-Committee on Stability and Load Lines and on Fishing Vessels Safety, at its fifty-first session. The Guidelines provide guidance for the flooding detection systems for watertight spaces below the bulkhead deck, required by SOLAS regulation II-1/22-1 for passenger ships carrying 36 or more persons and constructed on or after 1 July 2010.

2 Member Governments are invited to use the annexed Guidelines for flooding detection systems on passenger ships when applying the relevant provisions of SOLAS regulation II-1/22-1 and to bring them to the attention of all parties concerned.

## ANNEX

### GUIDELINES FOR FLOODING DETECTION SYSTEMS ON PASSENGER SHIPS

#### Introduction

1 SOLAS regulation II-1/22-1 requires passenger ships carrying 36 or more persons constructed on or after 1 July 2010 to be provided with flooding detection systems for watertight spaces below the bulkhead deck based on guidelines developed by the Organization.

2 These guidelines are intended to provide detailed requirements for flooding detection systems to provide information in the case of flooding in order to assess the actual flooding situation and support the decision-making process.

#### Definitions

3 *Flooding detection system* means a system of sensors and alarms that detect and warn of water ingress into watertight spaces. Continuous flood level monitoring may be provided, but is not required.

4 *Sensor* means a device fitted at the location being monitored that activates a signal to identify the presence of water at the location.

5 *Alarm* means an audible and visual signal which announces a flooding condition requiring attention.

#### System installation

6 A flooding detection system should be fitted in all watertight spaces below the bulkhead deck that:

- .1 have a volume in cubic metres ( $m^3$ ) that is more than the ship's moulded displacement per centimetre (cm) immersion at deepest subdivision draught; or
- .2 have a volume more than  $30 m^3$ ,

whichever is the greater.

7 Any watertight spaces that are separately equipped with a liquid level monitoring system (such as fresh water, ballast water, fuel, etc.), with an indicator panel or other means of monitoring at the navigation bridge (and the safety centre if located in a separate space from the navigation bridge), are excluded from these requirements.

#### Sensor installation

8 The number and location of flooding detection sensors should be sufficient to ensure that any substantial water ingress into a watertight space requiring a flooding detection system is detected under reasonable angles of trim and heel. To accomplish this, flooding detection sensors required in accordance with paragraph 6 should generally be installed as indicated below:

- .1 **Vertical location** – sensors should be installed as low as practical in the watertight space.
- .2 **Longitudinal location** – in watertight spaces located forward of the mid-length, sensors should generally be installed at the forward end of the space; and in watertight spaces located aft of the mid-length, sensors should generally be installed at the aft end of the space. For watertight spaces located in the vicinity of the mid-length, consideration should be given to the appropriate longitudinal location of the sensor. In addition, any watertight space of more than  $L_s/5$  in length or with arrangements that would seriously restrict the longitudinal flow of water should be provided with sensors at both the forward and aft ends.
- .3 **Transverse location** – sensors should generally be installed at the centreline of the space (or alternatively at both the port and starboard sides). In addition, any watertight space that extends the full breadth of the ship or with arrangements that would seriously restrict the transverse flow of water should be provided with sensors at both the port and starboard sides.

9 Where a watertight space extends in height over more than one deck, there should be at least one flooding detection sensor at each deck level. This provision is not applicable in cases where a continuous flood level monitoring system is installed.

### **Unusual arrangements**

10 For watertight spaces with unusual arrangements or in other cases where this guidance would not achieve the intended purpose, the number and location of flooding detection sensors should be subject to special consideration.

### **Alarm installation**

11 Each flooding detection system should give an audible and visual alarm at the navigation bridge and the safety centre, if located in a separate space from the navigation bridge. These alarms should indicate which watertight space is flooded.

12 Visual and audible alarms should conform to the Code on Alarms and Indicators, 1995, as may be amended, as applicable to a *primary alarm* for the preservation or safety of the ship.

### **Design requirements**

13 The flooding detection system and equipment shall be suitably designed to withstand supply voltage variation and transients, ambient temperature changes, vibration, humidity, shock, impact and corrosion normally encountered in ships. Sensor cabling and junction boxes should be suitably rated to ensure operability of the detection system in a flooded condition. In addition, the detection system should be designed on the fail-to-safety principle, where an open sensor circuit should result in an alarm condition.\*

14 The flooding detection system should be continuously powered and should have an automatic change-over to a stand-by power supply in case of loss of the normal power supply. Failure of the normal power supply should be indicated by an alarm.\*

---

\* Refer to the Code on Alarms and Indicators, 1995, as amended.

**Detector maintenance, accessibility and testing**

15 Documented operating, maintenance and testing procedures for the flooding detection system should be kept on board and be readily accessible.

16 Flooding detection system sensors and equipment should be installed where they are accessible for testing, maintenance and repair.

17 The flooding detection system should be capable of being functionally tested using either direct or indirect methods. Records of testing should be retained on board.

\*\*\*

**ANNEX 3****JUSTIFICATION FOR INCLUSION OF A NEW ITEM ON “REVISION OF SOLAS CHAPTER II-1 SUBDIVISION AND DAMAGE STABILITY REGULATIONS” IN THE SUB-COMMITTEE’S WORK PROGRAMME****Scope of the proposal**

The scope should include consideration of the need for a revision of those SOLAS chapter II-1 regulations already identified in SLF 51/3/2, SLF 51/3/3 and SLF 51/3/4 and also include any additional items identified as experience is gained in the application of the new regulations. Interpretations included in the Explanatory Notes to the SOLAS chapter II-1 subdivision and damage stability regulations as adopted by MSC 85 should also be taken into account.

**Need or compelling need**

In the process of developing Explanatory Notes for the new SOLAS chapter II-1 subdivision and damage stability regulations, various regulations have been identified as either needing or being potential candidates for future improvement. In the process of gaining experience in the application of the new SOLAS provisions, a need for improvements can be foreseen.

Furthermore, in the process of the work on the above Explanatory Notes, a number of interpretations could not be finalized as they would have necessitated modifications to the text of the SOLAS regulations. These also need to be taken into account.

**Analysis of the issues involved, having regard to both the costs to the maritime industry, as well as the associated legislative and administrative burden, at global level**

Adjusting the text as included in the new SOLAS chapter II-1 adopted by resolution MSC.216(82).

**Benefits which would accrue from the proposal**

An updated and improved version would contribute to ensure the safety standard as defined in the new SOLAS chapter II-1.

**Priority and target completion date**

The item should be regarded as high priority. Completion time could be within 2 sessions. Work should commence at SLF 53.

**Specific indication of the action required including draft texts of the proposed requirements, if possible**

It is expected that a Correspondence Group is necessary to commence the work.

**Is the subject of the proposal within the scope of IMO's objectives?**

Yes.

**How is the proposed item related to the scope of the Strategic plan for the Organization and fits into the High-level Action Plan?**

Strategic plan of the Organization (for the six-year period 2008-2013), resolution A.989(25):

Strategic direction SD 2: IMO will foster global compliance with its instruments governing international shipping and will promote their uniform implementation by Member States.

High-level Action Plan of the Organization and priorities for the 2008-2009 biennium, resolution A.990(25):

High-level action 2.1.1: Monitor and improve conventions, etc., and provide interpretation thereof if requested by Member States.

**Do adequate industry standards exist?**

No.

**Do the benefits justify the proposed action?**

Yes.

**Identification of which committee/subsidiary body(ies) are essential to complete the work**

SLF Sub-Committee.

**Estimation of the number of sessions needed to complete the work**

2 sessions.

\*\*\*

**ANNEX 4****DRAFT MSC CIRCULAR****EARLY APPLICATION OF THE INTERNATIONAL  
CODE ON INTACT STABILITY, 2008**

1 The Maritime Safety Committee, at its [eighty-fifth session (26 November to 5 December 2008)], adopted the International Code on Intact Stability, 2008 (2008 IS Code) by resolution MSC....(85), together with adoption of amendments to chapter II-1 of the International Convention for the Safety of Life at Sea, 1974, as amended (1974 SOLAS Convention) (resolution MSC....(85)) and the Protocol of 1988 relating to the International Convention on Load Lines, 1966 (1988 LL Protocol) (resolution MSC....(85)), in order to make the introduction and the provisions of part A of the 2008 IS Code mandatory under the Convention and the Protocol, which are expected to enter into force on [1 July 2010].

2 In adopting the aforementioned amendments, the Committee considered the recommendation by the Sub-Committee on Stability and Load lines and on Fishing Vessel Safety, at its fifty-first session (14 to 18 July 2008), that Contracting Governments to the 1974 SOLAS Convention and Parties to the 1988 LL Protocol may apply, in advance, the provisions of the 2008 IS Code before it has entered into force, and agreed to the recommendation.

3 The Committee, therefore, resolved that Contracting Governments to the 1974 SOLAS Convention and Parties to the 1988 LL Protocol may apply the 2008 IS Code in advance of the entry into force of the amendments to chapter II-1 of the 1974 SOLAS Convention and the 1988 LL Protocol that make the introduction and the provisions of part A of the 2008 IS Code mandatory.

4 Contracting Governments to the 1974 SOLAS Convention and Parties to the 1988 LL Protocol are invited to take account of this decision when surveying and certifying ships flying their flag [constructed on or after 5 December 2008].

\*\*\*





## ANNEX 5

ROADMAP TOWARDS ENTRY INTO FORCE OF THE  
1993 TORREMOLINOS PROTOCOL

## Action plan

2008	SLF 51	<ul style="list-style-type: none"> <li>– Preparation of action plan</li> <li>– Preparation of questionnaire</li> </ul>
	MSC 85	<ul style="list-style-type: none"> <li>– Endorsement of action plan (Interim Report)</li> </ul>
2009	Correspondence Group	<ul style="list-style-type: none"> <li>– To prepare draft Agreement</li> <li>– Secretariat to contact countries with a large fishing fleet to request information using the questionnaire</li> </ul>
2010	SLF 52	<p>(January)</p> <ul style="list-style-type: none"> <li>– Working Group to prepare a draft Agreement</li> <li>– If further work is needed to consider arrangements for the intersessional period</li> </ul>
	MSC 87	<ul style="list-style-type: none"> <li>– To receive interim report from SLF 52</li> </ul>
2011	SLF 53	<p>(January)</p> <ul style="list-style-type: none"> <li>– Working Group to finalize the Agreement</li> </ul>
	MSC 89	<ul style="list-style-type: none"> <li>– To endorse the Agreement to be adopted by IMO Assembly (27th session)</li> </ul>
	A 27	<ul style="list-style-type: none"> <li>– To adopt the Agreement</li> </ul>
2012		<ul style="list-style-type: none"> <li>– Countries to consider ratification of the 1993 Torremolinos Protocol under the terms and conditions contained in the Agreement (Countries will declare that they accept the 1993 Torremolinos Protocol under the Agreement, when they deposit an instrument of ratification)</li> </ul>
[2015]		<ul style="list-style-type: none"> <li>– The 1993 Torremolinos Protocol to come into force after ratifications by countries with a large fishing fleet</li> <li>– To start implementation of the 1993 Torremolinos Protocol under the terms and conditions contained in the agreement</li> </ul>

\*\*\*



## ANNEX 6

**PROPOSED REVISED WORK PROGRAMME OF THE SUB-COMMITTEE  
AND PROVISIONAL AGENDA FOR SLF 52**

**PROPOSED REVISED WORK PROGRAMME OF THE SUB-COMMITTEE**

		<b>Target completion date/number of sessions needed for completion</b>	<b>Reference</b>
1	<del>Analysis of intact stability casualty records</del> <del>— Strategic direction: 12.1</del> <del>— High-level action: 12.1.2</del> <del>— Planned output: 12.1.2.1 to .2</del>	Continuous	MSC 70/23, paragraph 20.4; SLF 30/18, paragraphs 4.16 and 4.17
2	<del>Analysis of damage cards</del> <del>— Strategic direction: 12.1</del> <del>— High-level action: 12.1.2</del> <del>— Planned output: 12.1.2.1</del>	Continuous	MSC 70/23, paragraph 20.4; SLF 50/19, section 12
3	<b>Consideration of IACS unified interpretations</b> <i>Strategic direction: 1.1</i> <i>High-level action: 1.1.2</i> <i>Planned output: 1.1.2.1</i>	Continuous	MSC 78/26, paragraph 22.12; SLF 51/17, section 9
H.1	<del><b>Development of explanatory notes for harmonized SOLAS chapter II-1</b></del> <del>— Strategic direction: 2.1</del> <del>— High-level action: 2.1.1</del> <del>— Planned output: 2.1.1.2</del>	2008	MSC 69/22, paragraph 20.60.1; SLF 50/19, section 3
H.2 H.1	<b>Safety of small fishing vessels</b> (in co-operation with DE, COMSAR, FP, NAV and STW, as necessary) <i>Strategic direction: 5.2</i> <i>High-level action: 5.2.1</i> <i>Planned output: 5.2.1.2</i>	2010	MSC 79/23, paragraphs 11.15 and 20.32; MSC 83/28, paragraph 25.53; SLF 51/17, section 14
H.3 H.2	<del><b>Revision of the Intact Stability Code</b></del> <b>Development of new generation intact stability criteria</b> <i>Strategic direction: 5.2</i> <i>High-level action: 5.2.1</i> <i>Planned output: 5.2.1.2</i>	2010	SLF 41/18, paragraph 3.14; MSC 83/28, paragraph 25.54; SLF 51/17, section 14

- Notes:**
- 1 “H” means a high priority item and “L” means a low priority item. However, within the high and low priority groups, items have not been listed in any order of priority.
  - 2 Struck-out text indicates proposed deletions and the shaded text shows proposed additions or changes.
  - 3 Items printed in bold letters have been selected for inclusion in the provisional agenda for SLF 52.

		<b>Target completion date/number of sessions needed for completion</b>	<b>Reference</b>
H.4 H.3	<b>Development of options to improve effect on ship design and safety of the 1969 TM Convention</b> <i>Strategic direction:</i> 2.1 <i>High-level action:</i> 2.1.1 <i>Planned output:</i> 2.1.1.2	2008 2011	MSC 81/25, paragraph 23.53; SLF 51/17, section 14
H.5	<b>Guidelines for uniform operating limitations on high-speed craft</b> (coordinated by DE) <del><i>Strategic direction:</i> 5.2</del> <del><i>High-level action:</i> 5.2.1</del> <del><i>Planned output:</i> 5.2.1.2</del>	2008	MSC 81/25, paragraph 23.45; SLF 50/19, section 7
H.6 H.4	<b>Time-dependent survivability of passenger ships in damaged condition</b> <i>Strategic direction:</i> 5.1 <i>High-level action:</i> 5.1.1 <i>Planned output:</i> 5.1.1.1	2009 2011	MSC 81/25, paragraph 23.54; SLF 51/17, section 14
H.7 H.5	<b>Guidance on the impact of open watertight doors on existing and new ship survivability</b> <i>Strategic direction:</i> 2.1 <i>High-level action:</i> 2.1.1 <i>Planned output:</i> 2.1.1.2	2008 2010	SLF 49/17, section 3; MSC 82/24, paragraph 21.56; SLF 51/17, section 14
H.8 H.6	<b>Stability and sea-keeping characteristics of damaged passenger ships in a seaway when returning to port by own power or under tow</b> <i>Strategic direction:</i> 5.1 <i>High-level action:</i> 5.1.1 <i>Planned output:</i> 5.1.1.1	2008 2011	MSC 82/24, paragraph 21.57; <del>SLF 50/19, section 8</del> SLF 51/17, section 14
H.9	<b>Guidelines for drainage systems in closed vehicle and ro-ro spaces and special category spaces</b> (in co-operation with FP) <del><i>Strategic direction:</i> 5.1</del> <del><i>High-level action:</i> 5.1.1</del> <del><i>Planned output:</i> 5.1.1.2</del>	2009	<del>MSC 83/28, paragraph 25.49</del>

		<b>Target completion date/number of sessions needed for completion</b>	<b>Reference</b>
H.10 H.7	<b>Guidelines for verification of damage stability requirements for tankers and bulk carriers</b> (in co-operation with DE and STW, as necessary) <i>Strategic direction:</i> 2.1 <i>High-level action:</i> 2.1.1 <i>Planned output:</i> 2.1.1.2	2009 2010	MSC 83/28, paragraphs 25.50 to 25.52; SLF 51/17, section 14
H.11 H.8	<b>Safety provisions applicable to tenders operating from passenger ships</b> (coordinated by DE) <i>Strategic direction:</i> 5.2 <i>High-level action:</i> 5.2.1 <i>Planned output:</i> -	<del>3 sessions</del> 2012	MSC 84/24, paragraph 22.57; SLF 51/17, section 14
H.12 H.9	<b>Damage stability regulations for ro-ro passenger ships</b> <i>Strategic direction:</i> 5.1 <i>High-level action:</i> 5.1.1 <i>Planned output:</i> -	<del>2 sessions</del> 2011	MSC 84/24, paragraph 22.59; SLF 51/17, section 14
H.13 H.10	<b>Development of an agreement on the implementation of the 1993 Torremolinos Protocol</b> (in co-operation with appropriate sub-committees, as necessary) <i>Strategic direction:</i> 5.2 <i>High-level action:</i> 5.2.1 <i>Planned output:</i> 5.2.1.4	<del>2 sessions</del> 2011	MSC 84/24, paragraph 22.62; SLF 51/17, section 14
[H.11]	Revision of SOLAS chapter II-1 subdivision and damage stability regulations** <i>Strategic direction:</i> 5.2 <i>High-level action:</i> 5.2.1 <i>Planned output:</i> -	2 sessions	SLF 51/17, section 14]

\* The Sub-Committee has been instructed to include the item in the provisional agenda for SLF 52.

\*\* Pending approval of MSC 85.

**PROPOSED PROVISIONAL AGENDA FOR SLF 52\***

- Opening of the session and election of Chairman and Vice-Chairman for 2010
- 1 Adoption of the agenda
  - 2 Decisions of other IMO bodies
  - 3 Development of new generation intact stability criteria
  - 4 Safety of small fishing vessels
  - 5 Development of options to improve effect on ship design and safety of the 1969 TM Convention
  - 6 Time-dependent survivability of passenger ships in damaged condition
  - 7 Guidance on the impact of open watertight doors on existing and new ship survivability
  - 8 Stability and sea-keeping characteristics of damaged passenger ships in a seaway when returning to port by own power or under tow
  - 9 Guidelines for verification of damage stability requirements for tankers and bulk carriers
  - 10 Safety provisions applicable to tenders operating from passenger ships
  - 11 Damage stability regulations for ro-ro passenger ships
  - 12 Development of an agreement on the implementation of the 1993 Torremolinos Protocol
  - 13 Consideration of IACS unified interpretations
  - 14 Work programme and agenda for SLF 53
  - 15 Election of Chairman and Vice-Chairman for 2011
  - 16 Any other business
  - 17 Report to the Maritime Safety Committee

\*\*\*

---

\* Agenda item numbers do not necessarily indicate priority.

## ANNEX 7

**STATUS OF PLANNED OUTPUTS IN THE HIGH-LEVEL ACTION PLAN FOR THE 2008-2009  
BIENNIUM RELATING TO THE SUB-COMMITTEE'S WORK**

Strategic Directions (SDs) (A.989(25))			High-level Actions (HLAs)		Planned outputs for 2008-2009	
<b>ENHANCING THE STATUS AND EFFECTIVENESS OF IMO</b>						
1	IMO is the primary international forum for technical matters of all kinds affecting international shipping and legal matters related thereto. An inclusive and comprehensive approach to such matters will be a hallmark of IMO. In order to maintain that primacy, it will:	1.1	Further develop its role in maritime affairs <i>vis-à-vis</i> other intergovernmental organizations, so as to be able to deal effectively and comprehensively with complex cross-agency issues	1.1.2	Co-operate with the United Nations and other international bodies on matters of mutual interest	1.1.2.1 Co-operation with:  Safety and security topics (MSC):  - IACS: consideration of unified interpretations <b>Status: In progress</b>
<i>The related performance indicators are: 1, 2, 3, 16, 17 and 19</i>						
2	IMO will foster global compliance with its instruments governing international shipping and will promote their uniform implementation by Member States			2.1.1	Monitor and improve conventions, etc., and provide interpretation thereof if requested by Member States	2.1.12 New or amended non-mandatory IMO instruments:  Safety and security topics (MSC):  - Explanatory Notes for a harmonized SOLAS chapter II-1 (see Output 5.2.1.2) <b>Status: SLF 51 completed the item and agreed to the draft MSC resolution for adoption at MSC 85</b>  - Guidelines for verification of damage stability requirements for tankers and bulk carriers <b>Status: SLF 51 gave preliminary consideration to the item</b>  - Guidance on the impact of open watertight doors on existing and new ship survivability <b>Status: SLF 51 progressed the item</b>  - Guidelines to improve the effect on ship design and safety of the 1969 TM Convention <b>Status: SLF 51 progressed the item</b>
<i>The related performance indicator is: 16</i>						
<b>DEVELOPING AND MAINTAINING A COMPREHENSIVE FRAMEWORK FOR SAFE, SECURE, EFFICIENT AND ENVIRONMENTALLY SOUND SHIPPING</b>						
5	IMO's highest priority will be the safety of human life at sea. In particular, greater emphasis will be accorded to:	5.1	Ensuring that all systems related to enhancing the safety of human life at sea are adequate, including those concerned with large concentrations of people	5.1.1	Review adequacy of passenger ship safety provisions	5.1.1.1 New or amended mandatory IMO instruments (MSC):  - Stability and sea-keeping characteristics of damaged passenger ships in a seaway when returning to port under own power or under tow <b>Status: SLF 51 progressed the item</b>

Strategic Directions (SDs) (A.989(25))			High-level Actions (HLAs)		Planned outputs for 2008-2009	
						<ul style="list-style-type: none"> <li>- Standards on time dependent survivability of passenger ships in damaged condition</li> </ul> <p><b>Status: SLF 51 progressed the item</b></p> <p><b>(new item)</b> <b>Status: MSC 84 approved the item on “Damage stability regulations for ro-ro passenger ships” and SLF 51 gave a preliminary consideration to the item</b></p>
					5.1.1.2	<p>New or amended non-mandatory IMO instruments (MSC):</p> <ul style="list-style-type: none"> <li>- Guidelines for drainage systems in closed vehicle, ro-ro and special category spaces of passenger ships (see Output 5.2.1.2)</li> </ul> <p><b>Status: SLF 51 finalized the item and referred the outcome to FP 53</b></p>
	5.2	Enhancing technical, operational and safety management standards	5.2.1	Keep under review the technical and operational safety aspects of all types of ships, including fishing vessels	5.2.1.1	<p>New or amended mandatory IMO instruments (MSC):</p> <ul style="list-style-type: none"> <li>- Amendments to resolution A.744(18) (see Output 5.3.1.1)</li> <li>- Amendments to SOLAS related to asbestos</li> <li>- Amendments to SOLAS related to the fire resistance of ventilation ducts</li> <li>- Interim guidelines for gas-fuelled engine installations in ships</li> </ul> <p><b>(new item)</b> <b>Status: MSC 84 approved the item on “Safety provisions applicable to tenders operating from passenger ships”</b></p> <p><b>(proposed item)</b> <b>Status: SLF 51 invited the Committee to approve the new item on Revision of SOLAS chapter II-1 subdivision and damage stability regulations</b></p>
					5.2.1.2	<p>New or amended non-mandatory IMO instruments (MSC):</p> <ul style="list-style-type: none"> <li>- Explanatory Notes for a harmonized SOLAS chapter II-1 (see Output 2.1.1.2 (safety and security topics))</li> </ul> <p><b>Status: SLF 51 finalized the item and agreed to the draft MSC resolution for adoption at MSC 85</b></p> <ul style="list-style-type: none"> <li>- Guidelines for drainage systems in closed vehicle, ro-ro and special category spaces for cargo ships (see Output 5.1.1.2)</li> </ul> <p><b>Status: SLF 51 finalized the item and referred the outcome to FP 53</b></p> <ul style="list-style-type: none"> <li>- Guidelines for uniform operating limitations of high-speed craft</li> </ul> <p><b>Status: SLF 51 finalized the item and referred the outcome to DE 52</b></p> <ul style="list-style-type: none"> <li>- Guidelines for verification of damage stability requirements for tankers and bulk carriers</li> </ul> <p><b>Status: SLF 51 gave preliminary consideration to the item</b></p>



Strategic Directions (SDs) (A.989(25))				High-level Actions (HLAs)		Planned outputs for 2008-2009	
							<ul style="list-style-type: none"> <li>- Guidelines to enhance the safety of small fishing vessels <b>Status: SLF 51 progressed the item</b></li> <li>- Revised Intact Stability Code <b>Status: SLF 51 progressed the item and invited the Committee to modify the title of the item as Development of new generation intact stability criteria</b></li> </ul>
						5.2.1.3	Promotion of the implementation of resolution A.925(22) on <i>Entry into force of the 1993 Torremolinos Protocol and the 1995 STCW-F Convention</i> (MSC) (see Outputs 1.12.1 (safety and security topics) and 5.2.1.4)  <b>Status: MSC 84 approved the item on “Development of an agreement on the implementation of the 1993 Torremolinos Protocol” and SLF 51 gave preliminary consideration to the item</b>
						5.2.1.4	Legal and technical options to facilitate and expedite the earliest possible entry into force of the 1993 Torremolinos Protocol, as called for under resolution A.1003(25) (MSC) (see Outputs 1.1.2.1 (safety and security topics) and 5.2.1.3)  <b>Status: MSC 84 approved the item on “Development of an agreement on the implementation of the 1993 Torremolinos Protocol” and SLF 51 gave preliminary consideration to the item</b>
<i>The related performance indicators are: 4(b), 5(b), 6, 7, 8, 10, 11, 14 and 17(b)</i>							
12	IMO will take the lead in enhancing the quality of shipping by:	12.1	Encouraging the utilization of the best available techniques not entailing excessive costs, in all aspects of shipping	12.1.1	Use formal safety assessment techniques in the development of technical standards		
				12.1.2	Use risk-based tools that take account of costs and the human element in the development of operational standards	12.1.2.1	<ul style="list-style-type: none"> <li>- Guidelines for all sub-committees on the casualty analysis process (MSC) <b>Status: SLF 51 invited the Committee to delete continuous items on Analysis of intact stability casualty records and Analysis of damage cards</b></li> </ul>
						12.1.2.2	A casualty analysis process effectively implemented and monitored (MSC)

\*\*\*



**ANNEX 8****STATEMENT BY THE DELEGATIONS OF SWEDEN AND THE UNITED STATES**

Following a proposal from SLF 49, MSC 82 included in the Sub-Committee's work programme a new high priority item on "Guidance on the impact of open watertight doors on existing and new ship survivability", with a target completion date of 2008. At the same time a new high-priority item on "Guidance to ensure consistent policy for determining the need for watertight doors to remain open during navigation" was put in the work programme for the DE Sub-Committee. The SOLAS text to which both these items are related reads "Such determination shall be made by the Administration only after careful consideration of the impact on ship operations and survivability", and is equally applicable to existing and new ships.

Unfortunately, SLF 51 was not able to conclude the item and during the discussion some delegations stated that it would not be reasonable to use the same guidance for existing ships as for new ships. Sweden and the United States cannot understand nor accept this view. The guidance to be developed by the SLF Sub-Committee concerns the physical effect of open watertight doors, which of course is dependent on the position of the doors and the subdivision and stability standard, but in no respect on the age of the ship.

If Administrations for any reason would come to different conclusions when applying this guidance for existing and for new ships is an issue which should not have any influence on the technical content of the guidance.

---