

MARITIME SAFETY COMMITTEE  
92nd session  
Agenda item 26

MSC 92/26/Add.1  
28 June 2013  
Original: ENGLISH

**REPORT OF THE MARITIME SAFETY COMMITTEE ON  
ITS NINETY-SECOND SESSION**

Attached are annexes 1 to 16, 18 to 24 and 26 to 30 to the report of the Maritime Safety Committee on its ninety-second session (MSC 92/26).



**LIST OF ANNEXES**

ANNEX 1	RESOLUTION MSC.349(92) – CODE FOR RECOGNIZED ORGANIZATIONS (RO CODE)
ANNEX 2	RESOLUTION MSC.350(92) – AMENDMENTS TO THE INTERNATIONAL CONVENTION FOR THE SAFETY OF LIFE AT SEA, 1974, AS AMENDED
ANNEX 3	RESOLUTION MSC.351(92) – AMENDMENTS TO THE INTERNATIONAL CODE OF SAFETY FOR HIGH-SPEED CRAFT, 1994 (1994 HSC CODE)
ANNEX 4	RESOLUTION MSC.352(92) – AMENDMENTS TO THE INTERNATIONAL CODE OF SAFETY FOR HIGH-SPEED CRAFT, 2000 (2000 HSC CODE)
ANNEX 5	RESOLUTION MSC.353(92) – AMENDMENTS TO THE INTERNATIONAL MANAGEMENT CODE FOR THE SAFE OPERATION OF SHIPS AND FOR POLLUTION PREVENTION (INTERNATIONAL SAFETY MANAGEMENT (ISM) CODE)
ANNEX 6	RESOLUTION MSC.354(92) – AMENDMENTS TO THE INTERNATIONAL MARITIME SOLID BULK CARGOES (IMSBC) CODE
ANNEX 7	RESOLUTION MSC.355(92) – AMENDMENTS TO THE INTERNATIONAL CONVENTION FOR SAFE CONTAINERS (CSC), 1972
ANNEX 8	RESOLUTION MSC.356(92) – AMENDMENTS TO THE PROTOCOL OF 1988 RELATING TO THE INTERNATIONAL CONVENTION ON LOAD LINES, 1966, AS AMENDED
ANNEX 9	RESOLUTION MSC.357(92) – AMENDMENTS TO THE CODE FOR THE CONSTRUCTION AND EQUIPMENT OF MOBILE OFFSHORE DRILLING UNITS (MODU CODE)
ANNEX 10	RESOLUTION MSC.358(92) – AMENDMENTS TO THE CODE FOR THE CONSTRUCTION AND EQUIPMENT OF MOBILE OFFSHORE DRILLING UNITS, 1989 (1989 MODU CODE)
ANNEX 11	RESOLUTION MSC.359(92) – AMENDMENTS TO THE CODE FOR THE CONSTRUCTION AND EQUIPMENT OF MOBILE OFFSHORE DRILLING UNITS, 2009 (2009 MODU CODE)
ANNEX 12	RESOLUTION MSC.360(92) – AMENDMENTS TO THE CODE OF SAFETY FOR DYNAMICALLY SUPPORTED CRAFT (DSC CODE)
ANNEX 13	DRAFT AMENDMENTS TO SOLAS CHAPTER II-2
ANNEX 14	DRAFT AMENDMENTS TO THE INTERNATIONAL CODE FOR FIRE SAFETY SYSTEMS (FSS CODE)
ANNEX 15	RESOLUTION MSC.361(92) – OPERATION OF THE INTERNATIONAL LRIT DATA EXCHANGE AFTER 2013

---

ANNEX 16	DRAFT AMENDMENTS TO THE INTERNATIONAL CODE FOR THE CONSTRUCTION AND EQUIPMENT OF SHIPS CARRYING DANGEROUS CHEMICALS IN BULK (IBC CODE)
ANNEX 18	RESOLUTION MSC.362(92) – REVISED RECOMMENDATION ON A STANDARD METHOD FOR EVALUATING CROSS-FLOODING ARRANGEMENTS
ANNEX 19	DRAFT AMENDMENTS TO THE CODE FOR THE CONSTRUCTION AND EQUIPMENT OF SHIPS CARRYING DANGEROUS CHEMICALS IN BULK (BCH CODE)
ANNEX 20	DRAFT AMENDMENTS TO THE CODE FOR EXISTING SHIPS CARRYING LIQUEFIED GASES IN BULK (EGC CODE)
ANNEX 21	DRAFT AMENDMENTS TO THE CODE FOR THE CONSTRUCTION AND EQUIPMENT OF SHIPS CARRYING LIQUEFIED GASES IN BULK (GC CODE)
ANNEX 22	DRAFT ASSEMBLY RESOLUTION – USE OF NATIONAL TONNAGE IN APPLYING INTERNATIONAL CONVENTIONS
ANNEX 23	RESOLUTION MSC.363(92) – PERFORMANCE STANDARDS FOR ELECTRONIC INCLINOMETERS
ANNEX 24	RESOLUTION MSC.364(92) – PROCEDURE FOR CALCULATING THE NUMBER OF FISHING VESSELS OF EACH CONTRACTING STATE TO THE 2012 CAPE TOWN AGREEMENT BY THE DEPOSITARY
ANNEX 26	DRAFT ASSEMBLY RESOLUTION ON NOTIFICATION AND CIRCULATION THROUGH THE GLOBAL INTEGRATED SHIPPING INFORMATION SYSTEM (GISIS)
ANNEX 27	DRAFT ASSEMBLY RESOLUTION ON GUIDELINES TO ASSIST INVESTIGATORS IN THE IMPLEMENTATION OF THE CASUALTY INVESTIGATION CODE (RESOLUTION MSC.255(84))
ANNEX 28	DRAFT ASSEMBLY RESOLUTION ON AMENDMENTS TO THE SURVEY GUIDELINES UNDER THE HARMONIZED SYSTEM OF SURVEY AND CERTIFICATION (HSSC), 2011
ANNEX 29	DRAFT ASSEMBLY RESOLUTION ON 2013 NON-EXHAUSTIVE LIST OF OBLIGATIONS UNDER INSTRUMENTS RELEVANT TO THE IMO INSTRUMENTS IMPLEMENTATION CODE
ANNEX 30	DRAFT ASSEMBLY RESOLUTION ON IMO SHIP IDENTIFICATION NUMBER SCHEME

**(See document MSC 92/26/Add.2 for annexes 25 and 31 to 39; and document MSC 92/26/Add.3 for annexes 17 and 40 to 46)**

\*\*\*



**ANNEX 1**

**RESOLUTION MSC.349(92)  
(Adopted on 21 June 2013)**

**CODE FOR RECOGNIZED ORGANIZATIONS (RO CODE)**

THE MARITIME SAFETY COMMITTEE,

RECALLING Article 28(b) of the Convention on the International Maritime Organization concerning the functions of the Committee,

RECALLING ALSO resolution A.739(18) entitled *Guidelines for the authorization of organizations acting on behalf of the Administration*, as amended by resolution MSC.208(81), and resolution A.789(19) entitled *Specifications on the survey and certification functions of recognized organizations acting on behalf of the Administration*, which have become mandatory under chapter XI-1 of the International Convention for the Safety of Life at Sea (SOLAS), 1974 (hereinafter referred to as "the 1974 SOLAS Convention"), under chapter I of annex I to annex B of the Protocol of 1988 relating to the International Convention on Load Lines, 1966 (hereinafter referred to as "the 1988 Load Lines Protocol"), and under Annex I and Annex II of the MARPOL Convention,

RECOGNIZING the need to update the aforementioned resolutions, gather all the applicable requirements for recognized organizations in a single IMO mandatory instrument and assist in achieving harmonized and consistent global implementation of requirements established by IMO instruments for the assessment and authorization of recognized organizations,

RECOGNIZING ALSO the need for a code to provide, as far as national laws allow, a standard approach to assist the Administrations in meeting their responsibilities in recognizing, authorizing and monitoring their recognized organizations,

NOTING resolutions MSC.350(92) and MSC.356(92), by which it adopted, inter alia, amendments to the 1974 SOLAS Convention and to the 1988 Load Lines Protocol, respectively, to make the provisions of part 1 and part 2 of the Code for recognized organizations mandatory under the 1974 SOLAS Convention and the 1988 Load Lines Protocol,

NOTING ALSO resolution MEPC.237(65) by which the Marine Environment Protection Committee adopted the Code for recognized organizations to be made mandatory under annex I and annex II of the Protocol of 1978 relating to the International Convention for the Prevention of Pollution from Ships, 1973,

HAVING CONSIDERED, at its ninety-second session, the text of the proposed Code for recognized organizations,

CONSIDERING that it is highly desirable for the Code for recognized organizations made mandatory under the MARPOL Convention, the 1974 SOLAS Convention and the 1988 Load Lines Protocol to remain identical,

1. ADOPTS the Code for recognized organizations (RO Code), the text of which is set out in the annex to the present resolution;

2. INVITES Contracting Governments to the 1974 SOLAS Convention and Parties to the 1988 Load Lines Protocol to note that the RO Code will take effect on 1 January 2015 upon the entry into force of the respective amendments to the 1974 SOLAS Convention and 1988 Load Lines Protocol;

3. REQUESTS the Secretary-General to transmit certified copies of the present resolution and the text of the RO Code contained in the annex to all Contracting Governments to the 1974 SOLAS Convention and Parties to the 1988 Load Lines Protocol;

4. ALSO REQUESTS the Secretary-General to transmit copies of this resolution and the annex to all Members of the Organization which are not Contracting Governments to the 1974 SOLAS Convention or Parties to the 1988 Load Lines Protocol;

5. RECOMMENDS Governments concerned to use the recommendatory provisions contained in part 3 of the RO Code as a basis for relevant standards, unless their national requirements provide at least an equivalent degree of safety.

\* \* \*

ANNEX

**CODE FOR RECOGNIZED ORGANIZATIONS (RO CODE)**

**Contents**

PREAMBLE

PART 1 – GENERAL

- 1 PURPOSE
- 2 SCOPE
- 3 CONTENTS
- 4 DELEGATION OF AUTHORITY
- 5 COMMUNICATION OF INFORMATION
- 6 REFERENCES

PART 2 – RECOGNITION AND AUTHORIZATION REQUIREMENTS FOR ORGANIZATIONS

- 1 TERMS AND DEFINITIONS
- 2 GENERAL REQUIREMENTS FOR RECOGNIZED ORGANIZATIONS
  - 2.1 General
  - 2.2 Rules and Regulations
  - 2.3 Independence
  - 2.4 Impartiality
  - 2.5 Integrity
  - 2.6 Competence
  - 2.7 Responsibility
  - 2.8 Transparency
- 3 MANAGEMENT AND ORGANIZATION
  - 3.1 General
  - 3.2 Quality safety and pollution prevention policy
  - 3.3 Documentation requirements
  - 3.4 Quality manual
  - 3.5 Control of documents
  - 3.6 Control of records
  - 3.7 Planning
  - 3.8 Organization
  - 3.9 Communication
    - 3.9.1 Internal communication

- 3.9.2 Communication/cooperation with flag State
    - 3.9.3 Cooperation between ROs
  - 3.10 Management review
    - 3.10.1 General
    - 3.10.2 Review input
    - 3.10.3 Review output
- 4 RESOURCES
  - 4.1 General
  - 4.2 Personnel
  - 4.3 Infrastructure
  - 4.4 Work environment
- 5 STATUTORY CERTIFICATION AND SERVICES PROCESSES
  - 5.1 General
  - 5.2 Design and development
  - 5.3 Design and development inputs
  - 5.4 Design and development outputs
  - 5.5 Design and development verification
  - 5.6 Control of design and development changes
  - 5.7 Control of production and service provisions
  - 5.8 Property of clients
  - 5.9 Subcontracting and service suppliers
  - 5.10 Control of monitoring and measuring devices
  - 5.11 Complaints
  - 5.12 Appeals
- 6 PERFORMANCE MEASUREMENT, ANALYSIS AND IMPROVEMENT
  - 6.1 General
  - 6.2 Internal audit
  - 6.3 Vertical contract audit
  - 6.4 Monitoring and measurement of processes
  - 6.5 Control, monitoring and measurement of non-conformities; including statutory deficiencies



- 6.6 Improvement
  - 6.6.1 General
  - 6.6.2 Data analysis
  - 6.6.3 Sources of information
  - 6.6.4 Corrective action
  - 6.6.5 Preventative action

7 QUALITY MANAGEMENT SYSTEM CERTIFICATION

8 AUTHORIZATION OF RECOGNIZED ORGANIZATIONS

- 8.1 General
- 8.2 Legal basis of the functions under authorization
- 8.3 Specification of authorization
- 8.4 Resources
- 8.5 Instruments
- 8.6 Instructions
- 8.7 Records

PART 3 – OVERSIGHT OF RECOGNIZED ORGANIZATIONS

1 PURPOSE

2 SCOPE

3 REFERENCES

4 TERMS AND DEFINITIONS

5 ESTABLISHING AN OVERSIGHT PROGRAMME

- 5.1 Oversight
- 5.2 The flag State's supervision of duties delegated to an RO
- 5.3 Verification and monitoring

6 PRINCIPLES OF AUDITING

7 MANAGING AN OVERSIGHT PROGRAMME

- 7.1 General
- 7.2 Oversight programme objectives and extent
  - 7.2.1 Objectives of an oversight programme
  - 7.2.2 Extent of an oversight programme

- 7.3 Oversight programme responsibilities, resources and procedures
  - 7.3.1 Oversight programme responsibilities
  - 7.3.2 Oversight programme resources
  - 7.3.3 Oversight programme procedures
  - 7.3.4 Oversight programme implementation
  - 7.3.5 Oversight programme records
- 7.4 Oversight programme monitoring and reviewing

#### APPENDIX 1 – REQUIREMENTS FOR TRAINING AND QUALIFICATION OF RECOGNIZED ORGANIZATION'S TECHNICAL STAFF

- A1.1 Definitions
- A1.2 Trainee entry requirements
- A1.3 Modules
- A1.4 Theoretical training for survey and plan approval staff
- A1.5 Practical training for survey and plan approval staff
  - A1.5.1 General
  - A1.5.2 Plan approval staff
  - A1.5.3 Survey staff
  - A1.5.4 Examinations and tests for survey and plan approval staff
  - A1.5.5 Audit Staff
- A1.6 Qualification
- A1.7 Assessment of training effectiveness
- A1.8 Maintenance of qualification
- A1.9 Activity monitoring
  - A1.9.1 Purpose
  - A1.9.2 Monitoring
  - A1.9.3 Method
  - A1.9.4 Reporting
  - A1.9.5 Evaluation
  - A1.9.6 Implementation
- A1.11 Training of support staff
- A1.12 Records

APPENDIX 2 – SPECIFICATIONS ON THE SURVEY AND CERTIFICATION FUNCTIONS  
OF RECOGNIZED ORGANIZATIONS ACTING ON BEHALF OF THE  
FLAG STATE

A2.1 SCOPE

A2.2 AREAS OF INTEREST COVERED BY ELEMENTARY MODULES

A2.2.1 MANAGEMENT

Module 1A: Management functions

A2.2.2 TECHNICAL APPRAISAL

Module 2A: Hull structure

Module 2B: Machinery systems

Module 2C: Subdivision and stability

Module 2D: Load line

Module 2E: Tonnage

Module 2F: Structural fire protection

Module 2G: Safety equipment

Module 2H: Oil pollution prevention

Module 2I: NLS pollution prevention

Module 2J: Radio

Module 2K: Carriage of dangerous chemicals in bulk

Module 2L: Carriage of liquefied gases in bulk

A2.2.3 SURVEYS

Module 3A: Survey functions

A2.2.4 QUALIFICATIONS AND TRAINING

Module 4A: General qualifications

Module 4B: Radio survey qualifications

A2.3 SPECIFICATIONS PERTAINING TO THE VARIOUS CERTIFICATES

A2.3.1 PASSENGER SHIP SAFETY CERTIFICATE

Initial certification, renewal survey

A2.3.2 CARGO SHIP SAFETY CONSTRUCTION CERTIFICATE

Initial certification, annual/intermediate, renewal surveys

A2.3.3 CARGO SHIP SAFETY EQUIPMENT CERTIFICATE

Initial certification, annual, periodical, renewal surveys

A2.3.4 CARGO SHIP SAFETY RADIO CERTIFICATE

Initial certification, periodical, renewal surveys

- A2.3.5 INTERNATIONAL SAFETY MANAGEMENT CODE CERTIFICATION  
Initial certification, annual/intermediate verifications, renewal certification
- A2.3.6 INTERNATIONAL LOAD LINE CERTIFICATE  
Initial certification, annual, renewal surveys
- A2.3.7 INTERNATIONAL OIL POLLUTION PREVENTION CERTIFICATE  
Initial certification, annual, intermediate, renewal surveys
- A2.3.8 INTERNATIONAL POLLUTION PREVENTION CERTIFICATE FOR THE CARRIAGE OF NOXIOUS LIQUID SUBSTANCES IN BULK  
Initial certification, annual, intermediate, renewal surveys
- A2.3.9 INTERNATIONAL CERTIFICATE OF FITNESS FOR THE CARRIAGE OF DANGEROUS CHEMICALS IN BULK  
Initial certification, annual, intermediate, renewal surveys
- A2.3.10 INTERNATIONAL CERTIFICATE OF FITNESS FOR THE CARRIAGE OF LIQUEFIED GASES IN BULK  
Initial certification, annual, intermediate, renewal surveys
- A2.3.11 INTERNATIONAL TONNAGE CERTIFICATE (1969)  
Initial certification

#### APPENDIX 3 – ELEMENTS TO BE INCLUDED IN AN AGREEMENT

## **PREAMBLE**

The *Code for Recognized Organizations (RO Code)* was adopted by the Organization by resolutions MSC.349(92) and MEPC.237(65).

This Code:

- .1 provides flag States with a standard that will assist in achieving harmonized and consistent global implementation of requirements established by the instrument of the International Maritime Organization (IMO) for the assessment and authorization of recognized organizations (ROs);
- .2 provides flag States with harmonized, transparent and independent mechanisms, which can assist in the consistent oversight of ROs in an efficient and effective manner; and
- .3 clarifies the responsibilities of organizations authorized as ROs for a flag State and overall scope of authorization.

## **PART 1**

### **GENERAL**

#### **1 PURPOSE**

The Code serves as the international standard and consolidated instrument containing minimum criteria against which organizations are assessed towards recognition and authorization and the guidelines for the oversight by flag States.

#### **2 SCOPE**

2.1 The Code applies to:

- .1 all organizations being considered for recognition or that are recognized by a flag State to perform, on its behalf, statutory certification and services under mandatory IMO instruments and national legislation; and
- .2 all flag States that intend to recognize an organization to perform, on their behalf, statutory certification and services under mandatory IMO instruments.

2.2 The Code establishes:

- .1 the mandatory requirements that an organization shall fulfil to be recognized by a flag State (part 1);
- .2 the mandatory requirements that an RO shall fulfil when performing statutory certification and services on behalf of its authorizing flag States (part 2);
- .3 the mandatory requirements that flag States shall adhere to when authorizing an RO (part 2); and
- .4 guidelines for flag State oversight of ROs (part 3).

2.3 The Code defines the functional, organizational and control requirements that apply to ROs conducting statutory certification and services performed under mandatory IMO instruments, such as, but not limited to, SOLAS, MARPOL and the Load Lines Conventions.

2.4 All requirements of the Code are generic and applicable to all ROs, regardless of their type and size and the statutory certification and services provided.

2.5 ROs subject to this Code need not offer all types of statutory certification and services and may have a limited scope of recognition, provided that the requirements of this Code are applied in a manner that is compatible with the limited scope of recognition. Where any requirement of this Code cannot be applied due to the scope of services delivered by an RO, this shall be clearly identified by the flag State and recorded in the RO's quality management system.

### **3 CONTENTS**

The Code consists of three parts. Part 1 contains general provisions. Part 2 contains mandatory provisions for the flag State and RO as already contained in relevant IMO instruments and applicable international standards. Part 3 contains guidelines for the oversight of ROs by flag States.

### **4 DELEGATION OF AUTHORITY**

4.1 A flag State may delegate authority to an organization recognized as complying with the provisions of this Code to perform, on its behalf, statutory certification and services under mandatory IMO instruments and its national legislation.

4.2 The flag State shall not authorize functions beyond RO's capabilities. In this respect, the flag State shall take into consideration appendix 2 of this Code for authorization.

4.3 Flag States should cooperate with each other with the objective of ensuring that ROs to whom they delegate authority adhere to the provisions of this Code.

### **5 COMMUNICATION OF INFORMATION**

The flag State shall communicate to, and deposit with, the Secretary-General of IMO a list of ROs for circulation to the interested parties for information of their officers, and a notification of the specific responsibilities and conditions of the authority delegated to ROs.

### **6 REFERENCES**

The Code is based on the following referenced documents:

- .1 mandatory IMO instruments and IMO Guidelines and recommendations (i.e. Codes, guidelines and standards recommended by the Organization);
- .2 ISO 9000:2005, Quality Management Systems – Fundamentals and vocabulary;
- .3 ISO 9001:2008, Quality Management Systems – Requirements;
- .4 ISO/IEC 17020:1998, General criteria for the operation of various types of bodies performing inspection;

- .5 ISO 19011:2002, Guidelines for quality and/or environmental management systems auditing;
- .6 International Association of Classification Societies (IACS) Quality Management System Requirements (QMSR); and
- .7 national legislation.

## PART 2

### RECOGNITION AND AUTHORIZATION REQUIREMENTS FOR ORGANIZATIONS

#### 1 TERMS AND DEFINITIONS

1.1 *Recognized organization (RO)* means an organization that has been assessed by a flag State, and found to comply with this part of the RO Code.

1.2 *Authorization* means the delegation of authority to an RO to perform statutory certification and services on behalf of a flag State as detailed in an agreement or equivalent legal arrangement taking into account the " Elements to be included in an Agreement" as set out in appendix 3 of this Code.

1.3 *Statutory certification and services* means certificates issued, and services provided, on the authority of laws, rules and regulations set down by the Government of a sovereign State. This includes plan review, survey, and/or audit leading to the issuance of, or in support of the issuance of, a certificate by or on behalf of a flag State as evidence of compliance with requirements contained in an international convention or national legislation. This includes certificates issued by an organization recognized by the flag State in accordance with the provisions of SOLAS regulation XI-1/1, and which may incorporate demonstrated compliance with the structural, mechanical and electrical requirements of the RO under the terms of its agreement of recognition with the flag State.

1.4 *Assessment* means any activity to determine that the assessed entity fulfils the requirements of the relevant rules and regulations.

1.5 *Interested parties* means any person or legal entity who can demonstrate a justified interest in the survey and certification process and includes, inter alia, clients of the RO, shipowners, ship operators, shipbuilders, equipment manufacturers, shipping industry interests or associations, marine insurance interests or associations, trade associations, governmental regulatory bodies or other governmental services and non-governmental organizations.

1.6 *Location* is a place from which surveys are carried out and managed, or where plan approval is carried out, or from which processes are managed.

1.7 *Site* is the place at which a surveyor is based to cover a specific contract or a series of contracts including; but not limited to, a port, shipyard, firm, and company. All statutory certification and services at sites are to be controlled by a location.

1.8 A *Vertical Contract Audit (VCA)* is a contract/order specific audit of production processes, including witnessing work during attendance at a survey, audit or plan approval in progress and, as applicable, including relevant sub-processes. A VCA is carried out at a location or a site (Survey Station/Approval Office/Site) to verify the correct application of

relevant requirements in service realization for the specific work in that contract/order, and their interactions (relevant sub-processes include e.g. previous part surveys or UTM processes connected to the survey). Plan approval VCA may be carried out for completed tasks.

## **2 GENERAL REQUIREMENTS FOR RECOGNIZED ORGANIZATIONS**

### **2.1 General**

Delegation of authority by a flag State to an organization shall be subject to the confirmation of the capability of that organization to demonstrate that it has the capacity to deliver high standards of service and its compliance with the requirements of this Code and applicable national legislation.

### **2.2 Rules and regulations**

The RO shall establish, publish and systematically maintain its rules or regulations, a version of which shall be provided in the English language, for the design, construction and certification of ships and their associated essential engineering systems as well as provide for adequate research capability to ensure appropriate updating of the published criteria.

### **2.3 Independence**

The RO and its staff shall not engage in any activities that may conflict with their independence of judgement and integrity in relation to their statutory certification and services. The RO and its staff responsible for carrying out the statutory certification and services shall not be the designer, manufacturer, supplier, installer, purchaser, owner, user or maintainer of the item subject to the statutory certification and services, nor the authorized representative of any of these parties. The RO shall not be substantially dependent on a single commercial enterprise for its revenue.

### **2.4 Impartiality**

2.4.1 The personnel of ROs shall be free from any pressures, which might affect their judgement in performing statutory certification and services. Procedures shall be implemented to prevent persons or organizations external to the organization from influencing the results of services carried out.

2.4.2 All potential customers shall have access to statutory certification and services provided by the RO without undue financial or other conditions. The procedures under which the RO operates shall be administered in a non-discriminatory manner.

### **2.5 Integrity**

The RO shall be governed by the principles of ethical behaviour, which shall be contained in a Code of Ethics. The Code of Ethics shall recognize the inherent responsibility associated with a delegation of authority to include assurance of adequate performance of services.

### **2.6 Competence**

The RO shall perform statutory certification and services by the use of competent surveyors and auditors who are duly qualified, trained and authorized to execute all duties and activities incumbent upon their employer, within their level of work responsibility.



## **2.7 Responsibility**

The RO shall define and document the responsibilities, authorities, qualifications and interrelation of personnel whose work affects the quality of its services.

## **2.8 Transparency**

2.8.1 Transparency reflects the principle of access to, or disclosure of, all information related to the statutory certification and services carried out by the RO on behalf of a flag State.

2.8.2 The ROs shall communicate information to the flag State as described in the section on communication/cooperation with the flag State.

2.8.3 Information concerning the status of ships certified by ROs shall be made available to the public.

## **3 MANAGEMENT AND ORGANIZATION**

### **3.1 General**

The RO shall, based on the provisions of this Code, develop and implement a quality management system and shall continually improve its effectiveness.

### **3.2 Quality, safety and pollution prevention policy**

The RO shall define and document its policy and objectives for, and commitment to, quality, safety and pollution prevention. In particular, the RO's management shall:

- .1 ensure that the policy and objectives are established;
- .2 ensure the policy and objectives are appropriate for the purpose of the organization;
- .3 communicate the policy and objectives; including provisions applicable to the statutory certification and services, to the organization and ensure that it is understood within the organization;
- .4 ensure sufficient availability of resources;
- .5 include a commitment to comply with all applicable requirements and continually improve the effectiveness of the quality management system;
- .6 conduct management reviews; which includes a framework for reviewing quality objectives; and
- .7 review the quality policy, objectives and the quality management system for continuing suitability.

### **3.3 Documentation requirements**

3.3.1 The quality management system shall include the following documentation:

- .1 quality policy and quality objectives;
- .2 quality manual (refer to section 3.4);
- .3 procedures and records required by this Code and the national legislation of the recognizing flag State;
- .4 procedures to ensure the effective planning, operation, and control of the RO's processes;
- .5 rules and regulations as applicable to the RO's areas of authorization;
- .6 list of ships for which statutory certification and services are provided;
- .7 other documented process procedures that are considered necessary (these include any circulars or letters, which provide the surveyors and administrative staff with up-to-date information on classification, statutory and related matters);
- .8 specifications and diagrams defining or amplifying service processes; and
- .9 pro-forma reports, checklists and certificates appropriate to the activities covered by this certification.

3.3.2 The quality management system shall also include external documents, such as:

- .1 national and international standards necessary for the activities governed by this instrument;
- .2 IMO Conventions and resolutions;
- .3 national shipping regulations and standards appropriate to the authorization of the RO;
- .4 documents and data submitted to the RO for verification and/or approval; and
- .5 specified correspondence defined by the RO to be of an important nature.

### **3.4 Quality manual**

The RO shall establish and maintain a quality manual that includes:

- .1 scope of the quality management system, including details of, and justification for any exclusions;
- .2 management statement on its policy and objectives for, and commitment to, quality;

- .3 description of the RO's areas of activity and competence;
- .4 general information about the organization and its head office (name, address, phone number, etc., and legal status);
- .5 information on the RO's relationship to its parent or associated organizations (where applicable);
- .6 charts describing the organization's structure;
- .7 management statement assigning a person designated who is responsible for the organization's quality management system;
- .8 relevant job descriptions;
- .9 policy statement on qualification and training of personnel;
- .10 documented procedures established for the quality management system, or reference to them;
- .11 description of the interaction between processes of the quality management system; and
- .12 description of all other documents required by the quality management system.

### **3.5 Control of documents**

3.5.1 Documents required by the quality management system shall be controlled. The provision of document control shall apply to any type of document, including but not limited to; electronic media and IT applications where said electronic media may affect the reliability of the service or of the recorded data.

3.5.2 A documented procedure shall be established to define the controls needed to:

- .1 approve documents for adequacy prior to issue;
- .2 review and update as necessary and re-approve documents;
- .3 ensure that changes and the current revision status of documents are identified;
- .4 ensure that relevant versions of applicable documents are available at points of use;
- .5 ensure that documents remain legible and readily identifiable;
- .6 ensure that documents of external origin determined by the RO to be necessary for the planning and operation of the quality management system are identified and their distribution is controlled; and
- .7 prevent the unintended use of obsolete documents, and to apply suitable identification if they are retained for any purpose.

### **3.6 Control of records**

3.6.1 Records shall be established to provide evidence of conformity to requirements of this Code and of the effective operation of the quality management system. The records shall be controlled.

3.6.2 The RO shall establish a documented procedure to define the controls needed for the identification, storage, protection, retrieval, retention, and disposition of records. Records shall remain legible, readily identifiable and retrievable.

3.6.3 The RO shall ensure that records are maintained, demonstrating achievement of the required standards in the terms covered by the statutory certification and services performed as well as the effective operation of the quality management system. Records, other than those set out in 3.6.4.2, shall be retained at least for the period for which statutory certification and services are provided by the RO. Records specified in 3.6.4.2 for a ship shall be retained for a minimum period of three years beyond the period for which statutory certification and services are provided by the RO to that ship, or a longer period if specified in the agreement between the flag State and the RO.

3.6.4 Records shall include at least those relevant to:

- .1 rules and regulations development and associated research;
- .2 the application of the rules and regulations and statutory requirements through:
  - .1 verification and/or approval of documents and/or drawings relevant to the design;
  - .2 approval and survey of materials and equipment;
  - .3 survey during construction and installation;
  - .4 survey during service; and
  - .5 issuance of certificates;
- .3 the list of ships; and
- .4 all other records required by this quality management system and any additional requirements established by the recognizing flag State.

### **3.7 Planning**

3.7.1 The RO shall ensure that quality objectives, including those needed to meet the requirements for statutory certification and services are established at relevant functions and levels within the organization.

3.7.2 The quality objectives shall be measurable and consistent with the quality policy.

3.7.3 The RO shall in its planning consider the elements identified below, and use the result to evaluate the effectiveness of its standards and procedures and their impact on safety of life and property and the marine environment:

- .1 that the planning of the quality management system is carried out in order to meet the requirements of the mandatory IMO Instruments, including but not limited to this Code, its quality management system and the authorizing flag State's national legislation;
- .2 that the integrity of the quality management system is maintained when changes to the quality management system are planned and implemented;
- .3 that the needs and expectations of the customers and other interested parties are taken into account, e.g. feedback from IMO, flag States and industry associations;
- .4 the effectiveness of services based on statistics from port State control, casualties, loss trends and feedback obtained from internal and external users;
- .5 the performance of the quality management system processes based on feedback from internal audits, non-conformities and internal comments;
- .6 lessons learned from previous experience and deriving from an examination of survey reports, casualty investigations or external sources; and
- .7 other sources of information which identifies opportunities for improvement.

3.7.4 The RO shall identify and plan the processes required for the quality management system, and determine the sequence and interaction of these processes.

3.7.5 The RO shall determine the requirements to be complied with and the criteria to ensure both the operation and control of these processes, including the criteria for acceptance, and evaluate the resources needed.

3.7.6 The RO shall plan and develop the processes required for statutory certification and services. Planning of the delivery of statutory certification and services shall be consistent with the requirements of other processes of the quality management system.

3.7.7 In planning the delivery of statutory certification and services, the RO shall determine the following as appropriate:

- .1 quality objectives and requirements for statutory certification and services;
- .2 the need to establish processes and documents, and to provide resources specific to the activity;
- .3 required verification, validation, monitoring, measurement, inspection and test activities and the criteria for acceptance; and
- .4 records needed to provide evidence that statutory certification and services meet the quality management system requirements; the requirements set out in the Code and the national legislation of the recognizing flag State.

3.7.8 The output of this planning shall be in a form suitable for the RO's structure and method of operations. The output of the planning should consider:

- .1 responsibility and authority for developing improvement plans;
- .2 skills and knowledge needed;
- .3 improvement approaches, methodology and tools;
- .4 resource requirements;
- .5 alternative planning needs;
- .6 indicators for performance achievements; and
- .7 the need for documentation and records.

### **3.8 Organization**

3.8.1 The relative size, structure, experience, and capability of the RO shall be commensurate with the type and degree of the statutory certification and services authorized by the flag State.

3.8.2 The RO shall demonstrate that it has the technical, administrative, and managerial competence and capacity to ensure the provision of quality services in a timely manner.

3.8.3 The RO shall appoint a member of its management who, irrespective of other responsibilities, shall have responsibility and authority that includes:

- .1 ensuring that processes needed for the quality management system are established, implemented, and maintained;
- .2 ensuring that processes required for the effective delivery of statutory certification and services are established, implemented and maintained;
- .3 reporting to top management on the performance of the quality management system; the delivery of statutory certification and services and any need for improvement; and
- .4 ensuring the promotion of awareness of all requirements throughout the RO.

3.8.4 The RO shall ensure that the responsibilities and authorities are defined and communicated within the RO.

### **3.9 Communication**

#### **3.9.1 *Internal communication***

The RO shall ensure that appropriate communication processes are established within the RO and that communication takes place regarding the effectiveness of the quality management system and statutory certification and services provided.

### **3.9.2 Communication/cooperation with flag State**

3.9.2.1 The RO shall establish appropriate communication processes with the authorizing flag State that, inter alia, address the following:

- .1 information specified by the flag State in terms of authorization;
- .2 classification of ships (assignments of class, changes and withdrawals), as applicable;
- .3 cases where a ship did not in all respects remain fit to proceed to sea without danger to the ship or persons on board or presenting unreasonable threat of harm to the marine environment;
- .4 information on all overdue surveys, overdue recommendations or overdue conditions of class, operating conditions or operating restrictions issued against their classed ships that shall be made available upon request by the authorizing flag State; and
- .5 other information as so specified by the authorizing flag State.

3.9.2.2 The RO shall allow participation in the development of its rules and/or regulations by the flag State.

3.9.2.3 The RO shall determine, propose and, if agreed by the flag State, implement effective arrangements for communicating with a flag State in relation to:

- .1 enquiries, contracts or other handling, including amendments; and
- .2 flag State feedback, including conformity issues pertaining to statutory certification and services.

### **3.9.3 Cooperation between ROs**

3.9.3.1 Under the framework established by the flag State, the ROs shall cooperate and share relevant experience with other ROs with the view to standardizing processes concerning statutory certification and services for the flag State, as appropriate.

3.9.3.2 Under the framework established by a flag State or a group of flag States, the organizations recognized by this State or these States shall establish and maintain appropriate technical and safety-related cooperation processes regarding statutory certification and services of ships, which may affect the validity of certificates issued by other ROs either in whole or in part on behalf of the said flag State(s). Flag States shall seek to mutually cooperate in order to ensure, as far as practicable, the compatibility of their respective frameworks.

3.9.3.3 No flag State shall mandate its ROs to apply to ships, other than those entitled to fly its flag, any requirement pertaining to their classification rules, requirements, procedures or performance of other statutory certification processes, beyond convention requirements and the mandatory instruments of the IMO.

3.9.3.4 In cases of transfer of the certification of the ship from one RO to another, the losing organization shall, without undue delay, provide the gaining organization access to the history file of the ship including:

- .1 any overdue surveys;
- .2 any overdue recommendations and overdue conditions of class;
- .3 operating conditions issued against the ship;
- .4 operating restrictions issued against the ship; and
- .5 technical information, drawings, plans and documents taking into account the relevant guidelines developed by the Organization<sup>1</sup>.

3.9.3.5 New certificates for the ship can be issued by the gaining organization only after all overdue surveys have been satisfactorily completed and all overdue recommendations or overdue conditions of class previously issued in respect of the ship have been completed as specified by the losing organization.

3.9.3.6 Within one month from the issuance of the certificates, the gaining organization shall advise the losing organization of the date of issue of the certificates and confirm the date, place and action taken to satisfy each overdue survey, overdue recommendation and overdue condition of class.

3.9.3.7 ROs shall establish and implement appropriate common requirements concerning cases of transfer of the certification of a ship where special precautions are necessary. Those cases shall, as a minimum, include the certification of ships of 15 years of age or over and the transfer of a ship from an organization not recognized by the flag State of the ship.

### **3.10 Management review**

#### **3.10.1 General**

The management of an RO shall review its quality management system; including a review of the RO's performance of statutory certification and services, at planned intervals, which shall not exceed 13 months, to ensure its continuing suitability, adequacy, and effectiveness. This review shall include assessing opportunities for improvement and the need for changes to the quality management system, including the quality policy and quality objectives.

#### **3.10.2 Review input**

The input to management review shall include the following information:

- .1 results of audits;
- .2 feedback from interested parties;
- .3 process performance and consistency of compliance with statutory requirements;

---

<sup>1</sup> MSC-MEPC.5/Circ.2 – *Guidelines for Administrations to ensure the adequacy of transfer of class-related matters between recognized organizations (ROs).*



- .4 status of preventive and corrective actions;
- .5 follow-up actions from previous management reviews;
- .6 changes that could affect the quality management system; and
- .7 recommendations for improvement.

Any output of management reviews containing information relevant to quality objectives, customer complaints and activity monitoring, throughout the RO, shall be used as input to the top management review.

### **3.10.3 Review output**

3.10.3.1 The output from management review shall include any decisions and actions related to:

- .1 improvement of the effectiveness of the quality management system and its processes;
- .2 improvement of services related to the requirements established in the authorization agreement; and
- .3 resource requirements.

3.10.3.2 Top management shall ensure that the results of the top management review of the quality management system, including the derived quality objectives, are documented and communicated throughout the organization, as appropriate.

3.10.3.3 Records from management reviews shall be maintained.

## **4 RESOURCES**

### **4.1 General**

4.1.1 The RO shall determine and provide the adequate resources in terms of technical, managerial and survey capabilities to accomplish the tasks being assigned and resources needed to implement the quality management system and to continually improve its effectiveness; and to enhance its performance in the delivery of statutory certification and services.

4.1.2 The RO shall be able to document extensive experience in assessing the design, construction and equipment of ships and the capability to effectively perform statutory certification and services on behalf of a flag State.

4.1.3 The RO shall have the capacity to:

- .1 provide for the publication and systematic maintenance of rules and/or regulations for the design, construction and certification of ships and their associated essential engineering systems as well as the provision of an adequate research capability to ensure appropriate updating of the published criteria. The RO is required to maintain an up-to-date version of this publication in the English language; and

- .2 allow participation in the development of its rules and/or regulations by representatives of the flag State and other interested parties.

## **4.2 Personnel**

4.2.1 The RO shall be equipped, at all times, with significant managerial, technical, support and research staff commensurate with the size of the fleet in its class, its composition and the organization's involvement in the construction, repair and conversion of ships. The RO shall be capable of assigning to every place of work, when and as needed, the means and staff commensurate with the tasks to be carried out in accordance with the requirements of this Code and those of the flag State.

4.2.2 The management of an RO shall have the competence, capability and capacity to organize, manage and control the performance of statutory certification and services in order to verify compliance with requirements relevant to the tasks delegated and shall, inter alia:

- .1 possess an adequate number of competent supervisory, technical appraisal and survey personnel;
- .2 develop and maintain appropriate procedures and instructions;
- .3 maintain up-to-date documentation on interpretation of the relevant instruments;
- .4 give technical and administrative support to field staff; and
- .5 review survey reports and plan approval letters for accuracy, compliance with requirements and to provide experience feedback for continual improvement.

4.2.3 The RO shall be established with a qualified staff to provide the required service representing an adequate geographical coverage and local representation as required.

4.2.4 The RO shall perform statutory certification and services by the use of only exclusive surveyors and auditors, being persons solely employed by the RO, duly qualified, trained and authorized to execute all duties and activities incumbent upon their employer, within their level of work responsibility. While still remaining responsible for the certification on behalf of the flag State, the RO may subcontract radio surveys to non-exclusive surveyors in accordance with section 5.9 of part 2 of this Code.

4.2.5 The RO's personnel performing and responsible for statutory certification and services shall have, as a minimum, the following formal education:

- .1 qualifications from a tertiary institution within a relevant field of engineering or physical science (minimum two-year programme); or
- .2 qualifications from a marine or nautical institution and relevant seagoing experience as a certificated ship officer, and
- .3 proficiency in the English language commensurate with the scope of statutory certification and services.

4.2.6 Other personnel assisting in the performance of statutory work shall have education, training and supervision commensurate with the tasks they are authorized to perform.

4.2.7 The RO shall have a documented system to track the qualifications of personnel; including continuous updating of their knowledge as appropriate to the tasks they are authorized to undertake. This system shall comprise appropriate training courses, including, inter alia, international instruments and appropriate procedures related to the delivery of statutory certification and services, as well as practical tutored training; it shall provide documented evidence of satisfactory completion of the training. As a minimum, the provisions in appendices 1 and 2 shall be met.

### **4.3 Infrastructure**

4.3.1 The RO shall determine, provide, and maintain the infrastructure required to perform statutory certification and services in accordance with the requirements of the mandatory IMO instruments. Infrastructure includes, as applicable:

- .1 building, workspaces and associated utilities;
- .2 process equipment (both hardware and software); and
- .3 supporting services, including but not limited to transport, communication, training and information systems.

4.3.2 Systems (hardware and software) provided to the surveyor shall be identified and relevant training on their use shall be carried out and documented. Special consideration should be given to the situation where a surveyor is working out of a home-based office.

### **4.4 Work environment**

4.4.1 The RO shall be satisfied that the work environment is safe and effective to perform statutory certification and services. While it is understood that such environmental conditions are not provided by the RO, the environmental conditions under which the survey will be permitted to take place shall be made clear to the customer prior to survey commencing.

4.4.2 The RO shall determine the necessary working procedures required to perform statutory certification and services safely and effectively. Training of staff on personal safety shall be carried out and documented.

4.4.3 Requirements for personal protective equipment to be used while performing statutory certification and services and procedures for personal safety of surveyors at work shall be established and documented.

## **5 STATUTORY CERTIFICATION AND SERVICES PROCESSES**

### **5.1 General**

It should be recognized that statutory certification and services are service delivery development processes for flag State and RO compliance verification activities rather than the design process for a ship or its equipment.

## **5.2 Design and development**

5.2.1 The RO shall plan and control the design and development of statutory certification and services processes. During the design and development planning, the organization shall determine:

- .1 the design and development stages;
- .2 the review, verification and validation that are appropriate to each service design and development stage; and
- .3 the responsibilities and authorities for design and development.

5.2.2 The RO shall allow participation in the development and review of its rules, procedures and/or regulations, specifically in the review process prior to finalization, by representatives of the flag State and interested parties.

5.2.3 The RO shall include in its rules and/or procedures:

- .1 requirements specified and communicated to ROs by the flag State, specifically for statutory certification and services<sup>2</sup>;
- .2 requirements not stated by the flag State but necessary for specified or intended use, as determined by the RO.

5.2.4 Implementation of requirements may be in the form of adoption into the RO's internal requirements or by use of the original documents from IMO or the flag State.

5.2.5 The RO shall not issue statutory certificates to a ship, irrespective of its flag, which has been declassified or is changing class for safety reasons, before giving the opportunity to the competent Administration of the flag State to give its opinion within a reasonable time as to whether a full inspection is necessary.

## **5.3 Design and development inputs**

5.3.1 Inputs relating to service requirements shall be determined and records maintained.

These inputs shall include:

- .1 applicable statutory and regulatory requirements;
- .2 where applicable, information derived from previous similar designs;
- .3 other requirements essential for design and development, such as functional and performance requirements; and
- .4 in-service experience with ships and mobile offshore drilling units obtained from within the RO itself and external sources.

---

<sup>2</sup> Refer to the *Code for the implementation of mandatory IMO instruments, 2011*, adopted by resolution A.1054(27), as may be amended.

5.3.2 The inputs shall be reviewed for adequacy. Requirements shall be complete, unambiguous and not in conflict with each other.

#### **5.4 Design and development outputs**

At suitable stages, systematic reviews of design and development of rules and standards shall be performed in accordance with planned arrangements to evaluate the ability of the results to meet requirements; and to identify any problems and propose necessary actions.

#### **5.5 Design and development verification**

Verification shall be performed in accordance with planned arrangements to ensure that the design and development outputs have met the design and development input requirements. Records of the results of the verification and any necessary actions shall be maintained.

#### **5.6 Control of design and development changes**

Design and development changes shall be identified and records maintained. The changes shall be reviewed, verified and validated, as appropriate, and approved before implementation. The review of the design and development changes shall include evaluation of the effect of the changes on the constituent parts and product already delivered. Records of the results of the review of changes and any necessary actions shall be maintained.

#### **5.7 Control of production and service provisions**

5.7.1 The RO shall ensure that all statutory certification and services are carried out under controlled conditions.

5.7.2 Controlled conditions shall include, as applicable:

- .1 the availability of information that describes the status and condition of ships surveyed and certified;
- .2 the availability of rules, regulations, work instructions, and other applicable standards, as necessary;
- .3 the use of suitable equipment;
- .4 the availability and use of monitoring and measuring equipment;
- .5 the implementation of monitoring and measurement;
- .6 the implementation of controls to ensure the accuracy of survey reports and certificates both before and after issuance; and
- .7 a safe work environment.

5.7.3 An RO shall conduct the statutory certification and services of the ship in conformity with all relevant international requirements and the requirements of this Code. When accepting a ship on behalf of the flag State that was constructed originally without a known flag State the RO shall verify that the ship complies with national requirements of that flag State prior to certification.

## **5.8 Property of clients**

The RO shall identify, verify, protect and safeguard property provided by the clients for performance of statutory certification and services. If property is lost, damaged or otherwise found to be unsuitable for use, the RO shall report this to the property owner and maintain relevant records.

## **5.9 Subcontracting and service suppliers**

5.9.1 Where an RO chooses to outsource any service that affects conformity to requirements or accepts work of a third party approved by the RO, the RO shall ensure that it fully controls the performance of such services. The flag State may increase the scope of control to be applied to these outsourced services. The process for outsourcing shall be defined within the RO's quality management system. For the purpose of accountability to the flag State, the work performed by the sub-contracted organization or service supplier constitutes the work of the RO and shall be subject to the requirements incumbent upon the RO under this Code.

5.9.2 Firms providing services on behalf of the owner of a ship or a mobile offshore drilling unit, the results of which are used by the RO in making decisions affecting the statutory certification and services shall be subject to approval and control by either the flag State or the RO in accordance with the procedures under their respective quality management system or the flag State requirements.

## **5.10 Control of monitoring and measuring devices**

5.10.1 The RO shall determine the monitoring and measurement to be undertaken and the monitoring and measurement equipment needed to provide evidence of conformity to the applicable requirements.

5.10.2 The RO shall establish processes to ensure that monitoring and measurement can be carried out in a manner that is consistent with the monitoring and measurement requirements.

5.10.3 Where necessary to ensure valid results, measuring equipment shall:

- .1 be calibrated or verified, or both, at specified intervals, or prior to use, against measurement standards traceable to international or national measurement standards; where no such standards exist, the basis used for calibration or verification shall be recorded;
- .2 be adjusted or re-adjusted as necessary;
- .3 have identification in order to determine its calibration status;
- .4 be safeguarded from adjustments that would invalidate the measurement result; and
- .5 be protected from damage and deterioration during handling, maintenance, and storage.

5.10.4 The RO shall assess and record the validity of previous measuring results when the equipment is found not to conform to requirements. The RO shall take appropriate action on the equipment affected. Records of results of calibration and verification shall be maintained.

5.10.5 When used in monitoring and measurement of specific requirements, the ability of computer software to satisfy the intended application shall be confirmed. This shall be undertaken prior to initial use and reconfirmed as necessary.

5.10.6 Where an RO is verifying testing at manufacturers, builders, repairers or owners premises and reporting the same, the RO shall ensure that the measuring devices used in the process are identified and that evidence of calibration is obtained. Where an RO is witnessing testing of service equipment installed or available on board a ship, a means shall be established so that the RO is satisfied as to the appropriate accuracy of the measuring equipment.

### **5.11 Complaints**

The RO shall have a documented process to address complaints related to statutory certification and services.

### **5.12 Appeals**

The RO shall have a documented process to address appeals related to statutory certification and services in accordance with the requirements of the flag State.

## **6 PERFORMANCE MEASUREMENT, ANALYSIS AND IMPROVEMENT**

### **6.1 General**

6.1.1 The RO shall plan and implement the monitoring, measurement, analysis and improvement processes needed to demonstrate conformity to statutory certification and services requirements, to ensure conformity of the quality management system, and to continually improve the effectiveness of the quality management system. This shall include the determination of applicable methods, including statistical techniques, and the extent of their use. The measurements employed by the RO shall be reviewed periodically, and data shall be verified on a continual basis for accuracy and completeness.

6.1.2 The RO shall develop key performance indicators with respect to the performance of statutory certification and services.

### **6.2 Internal audit**

6.2.1 The RO shall implement an audit programme; including the completion of internal audits at planned intervals to determine whether the authorized activity conforms to the planned arrangements and that the quality management system is effectively implemented and maintained, and that a supervisory system is in place, which monitors statutory certification and services.

6.2.2 The audit programme shall take into consideration the status and importance of the processes and areas to be audited, as well as the results of previous audits, flag State feedback, complaints and appeals including port State and flag State inspections. When planning the internal audits, consideration shall be given to complaints received in the past (either related to the location or in general) and to the results of previous internal audits and to the operation of the locations.

6.2.3 The RO shall define the audit criteria, scope, frequency, and methods. Auditors shall be suitably qualified and selected in order to ensure objectivity and impartiality of the audit process. Auditors shall not audit their own work. The audit scope shall cover the processes for the statutory certification and services at various locations with a focus on verification of the efficient and effective implementation of the quality management system and applicable work processes at the individual location. The audit periods, which may be established according to the findings, shall ensure that each location is audited at least once per three years. Audits at locations shall also include visits to selected sites, which operate under the control of the location.

6.2.4 A documented procedure shall be established to define the responsibilities and requirements for planning and conducting audits, establishing records and reporting results. Records of audits and their results shall be maintained.

6.2.5 The management responsible for the area being audited shall ensure that any necessary corrections and corrective actions are taken without undue delay to eliminate detected nonconformities, observations (potential non-conformities) and their root causes.

### **6.3 Vertical Contract Audit**

6.3.1 The RO shall carry out Vertical Contract Audits annually for each of the following processes:

- .1 plan approval;
- .2 new construction survey;
- .3 in-service periodical survey/audit; and
- .4 type approval (where applicable) or survey of other materials and equipment.

6.3.2 Evidence of completion of VCAs and findings thereof, shall be formally recorded.

### **6.4 Monitoring and measurement of processes**

6.4.1 The RO shall apply suitable methods for monitoring, including a supervisory system that monitors the work activities carried out, and where applicable, measurement of the quality management system processes. These methods shall demonstrate the ability of the processes to achieve sustained compliance with the requirements of this Code and the agreement with the flag State, in particular that:

- .1 the RO's rules and/or regulations are complied with; and
- .2 the requirements of the statutory certification and services are satisfied.

6.4.2 When planned results are not achieved, correction and corrective action shall be taken, as appropriate.

6.4.3 The implemented methods should consider issues such as, but not limited to:

- .1 port State control detentions;
- .2 casualties; and
- .3 rework of plan approval letters and survey reports.



## **6.5 Control, monitoring and measurement of non-conformities, including statutory deficiencies**

6.5.1 The RO shall monitor and measure the service delivery with statutory requirements and the RO's rules to verify that all requirements have been met. This shall be carried out at appropriate stages of the statutory certification and services process in accordance with the planned arrangements. Evidence of conformity with the statutory requirements and RO rules shall be maintained. Records shall indicate the person(s) approving or verifying compliance with the statutory requirements and the RO's rules.

6.5.2 The RO shall make provisions to ensure that non-conformities are identified and controlled. The controls and related responsibilities and authorities for dealing with non-conformities shall be defined in a documented procedure.

6.5.3 Where applicable, the RO shall deal with a non-conformity by one or more of the following ways:

- .1 by taking action to eliminate the detected non-conformity;
- .2 by authorizing its use, release or acceptance under the terms determined by the flag State;
- .3 when accepting with or without correction by exemption or equivalence, consideration should be given to the non-conformities with rules and regulations or statutory requirements during:
  - .1 drawing approval,
  - .2 survey of materials and equipment,
  - .3 survey during construction and installation,
  - .4 survey during service;
- .4 by taking action to preclude its original intended use or application; and
- .5 by taking action appropriate to the effects, or potential effects, of the non-conformity when a non-conformity is detected.

6.5.4 When a non-conformity is corrected, it shall be subject to reverification to demonstrate conformity to the requirements.

6.5.5 Records of the nature of non-conformities and any subsequent actions taken, including exemption or equivalences obtained, shall be maintained.

6.5.6 The RO shall comply with the instructions of the flag State detailing actions to be followed in the event that a ship is found not fit to proceed to sea without danger to the ship or persons on board, or presenting unreasonable threat of harm to the marine environment.

6.5.7 The ROs shall cooperate with port State control Administrations where a ship to which the RO issued the certificates is concerned, in particular, in order to facilitate the rectification of reported deficiencies or other discrepancies.

6.5.8 The RO responsible for issuing the relevant certificate shall, upon receiving a report of an accident or discovering a defect to a ship which affects the safety of the ship or the efficiency or completeness of its life saving appliances or other equipment, cause investigations to be initiated to determine whether a survey is necessary.

## **6.6 Improvement**

### **6.6.1 General**

The RO shall continually improve the effectiveness of its quality management system through the use of the quality policy, quality objectives, audit results, analysis of data, corrective and preventive actions and management review.

### **6.6.2 Data analysis**

6.6.2.1 The objective of data analysis is to determine the cause of problems to guide effective corrective and preventive action. The RO shall:

- .1 analyse data from various sources to assess performance against plans and goals and to identify areas for improvement;
- .2 make use of statistical methodologies for data analysis, which can help in assessing, controlling, and improving performance of processes; and
- .3 analyse the product requirements, as well as analysis of relevant processes, operations and quality records.

6.6.2.2 Information and data from all parts of the RO shall be integrated and analysed to evaluate the overall performance of the quality management system.

6.6.2.3 The results of analysis shall be documented and used to determine:

- .1 trends;
- .2 operational performance;
- .3 customer satisfaction and/or dissatisfaction through complaints or other quality indicators (PSC detentions, flag State non-conformities, etc.);
- .4 effectiveness and/or efficiency of processes; and
- .5 performance of suppliers.

### **6.6.3 Sources of information**

The RO shall identify sources of information and establish processes for collection of information for planning continual improvement, corrective and preventive actions. Such information shall include, inter alia:

- .1 customer complaints;
- .2 non-conformance reports;

- .3 outputs from management reviews;
- .4 internal audit reports;
- .5 outputs from data analysis;
- .6 relevant records;
- .7 outputs from customer feedback and satisfaction measurements;
- .8 process measurements;
- .9 results of self-assessment; and
- .10 in-service experience.

#### **6.6.4 Corrective action**

6.6.4.1 The RO shall without undue delay take action to eliminate the causes of non-conformities in order to prevent recurrence. Corrective actions shall be appropriate to the effects of the non-conformities encountered and address all actual or potential effects of these.

6.6.4.2 A documented procedure shall be established to define requirements for:

- .1 reviewing non-conformities (including complaints);
- .2 determining the cause of non-conformities;
- .3 evaluating the need for action to ensure that non-conformities do not recur;
- .4 determining and implementing action needed;
- .5 records of the results of action taken; and
- .6 reviewing the effectiveness of the corrective action taken.

#### **6.6.5 Preventive action**

6.6.5.1 The RO shall take action to identify and eliminate the causes of potential non-conformities in order to prevent their occurrence. Preventive actions shall be appropriate to the nature and effects of the potential problems.

6.6.5.2 A documented procedure shall be established to define requirements for:

- .1 determining potential non-conformities and their causes;
- .2 evaluating the need for action to prevent occurrence of non-conformities;
- .3 determining and implementing action needed;
- .4 records of results of action taken; and
- .5 reviewing the effectiveness of the preventive action taken.

6.6.5.3 Examples of such methodologies may include risk analyses, trend analyses, statistical process control, fault-tree analyses, failure modes and effects and criticality analyses.

## **7 QUALITY MANAGEMENT SYSTEM CERTIFICATION**

7.1 The RO shall develop, implement and maintain an effective internal quality management system that complies with the requirements of this Code and is based on appropriate parts of internationally recognized quality standards no less effective than the ISO 9000 series.

7.2 The RO's quality management system shall be periodically assessed and certified in accordance with the applicable international quality standards by a qualified body, accredited to comply with ISO/IEC 17021:2006 standard by an accreditation body that is signatory to the International Accreditation Forum (IAF) Multinational Recognition Agreement (MRA), recognized by the flag State as having the necessary governance and competences to act independently of the ROs or their associations and having the necessary means to carry out its duties effectively and to the highest professional standards, safeguarding the independence of the persons performing them.

7.3 In pursuance of continually improving RO and flag State services, IMO endeavours to closely monitor the certification and audit process of the RO and its implementation to ensure its continued relevance and validity to the maritime industry in general and to the ROs, in particular. IMO will establish the working methods and rules of procedure for such monitoring.

## **8 AUTHORIZATION OF RECOGNIZED ORGANIZATIONS**

### **8.1 General**

Under the provisions of regulation I/6 of SOLAS 1974, article 13 of LL 66, regulation 6 of MARPOL Annex I and regulation 8 of MARPOL Annex II and article 6 of TONNAGE 69, a flag State may authorize an RO to act on its behalf in statutory certification and services and determination of tonnages only to ships entitled to fly its flag as required by these conventions. Such authorizations shall not require ROs to perform actions that impinge on the rights of another flag State.

### **8.2 Legal basis of the functions under authorization**

The flag State shall establish the legal basis under which the authorization of statutory certification and services is administered. The following items shall be considered:

- .1 the formal written agreement with the RO;
- .2 acts, regulations and supplementary information;
- .3 interpretations; and
- .4 deviations and equivalent solutions.

### **8.3 Specification of authorization**

The flag State shall specify the scope of authorization granted to an RO. The following specifications shall be considered:

- .1 ship types and sizes;
- .2 conventions and other instruments, including relevant national legislation;
- .3 approval of drawings;
- .4 approval of materials and equipment;
- .5 surveys, audits, inspections;
- .6 issuance, endorsement and/or renewal of certificates;
- .7 corrective actions;
- .8 withdrawal or cancellation of certificates; and
- .9 reporting requirements.

### **8.4 Resources**

The flag State shall ensure that an RO has adequate resources in terms of technical, managerial and research capabilities to accomplish the tasks being assigned, in accordance with the minimum standards for ROs acting on behalf of the flag State set out in part 2 of this Code.

### **8.5 Instruments**

The flag State shall provide the RO with access to all appropriate instruments of national law giving effect to the provisions of the conventions, notify the RO of any additions, deletions or revisions thereto in advance of their effective date and specify whether the flag State's standards go beyond convention requirements in any respect.

### **8.6 Instructions**

8.6.1 The flag State shall issue specific instructions detailing the procedures to be followed in carrying out statutory certification and services, and actions to be followed in the event that a ship is found not fit to proceed to sea without danger to the ship or persons on board, or presenting unreasonable threat of harm to the marine environment.

8.6.2 Flag States shall ensure by appropriate means that ROs cooperate with each other in accordance with the provisions of this Code.

### **8.7 Records**

The flag State shall specify that the RO maintain records, which can provide the flag State with data to assist in interpretation of convention regulations.

## PART 3

### OVERSIGHT OF RECOGNIZED ORGANIZATIONS

#### 1 PURPOSE

Part 3 of the RO Code provides guidance on flag State's oversight of ROs authorized to perform statutory certification and services on its behalf. Part 3 also provides guidance on the principles of oversight that may include ship inspection, auditing, and monitoring activities.

#### 2 SCOPE

Part 3 of the RO code is applicable to all flag States that have authorized ROs to perform statutory certification and services. Part 3 includes flag State oversight provisions and provides guidance, which is non-mandatory, to assist flag States in the development and implementation of an effective oversight programme of ROs.

#### 3 REFERENCES

The following documents are referenced:

- .1 mandatory IMO instruments;
- .2 ISO 9000:2005, Quality Management Systems – Fundamentals and vocabulary;
- .3 ISO 9001:2008, Quality Management Systems – Requirements;
- .4 ISO/IEC 17020:1998, General Criteria for the operation of various types of bodies performing inspection;
- .5 ISO 19011:2002, Guidelines for quality and/or environmental management systems auditing; and
- .6 national legislation.

#### 4 TERMS AND DEFINITIONS

4.1 *Audit* means a systematic, independent, and documented process for obtaining audit evidence and evaluating it objectively to determine the extent to which the audit criteria are fulfilled. Auditing is characterized by reliance on a number of principles. These make the audit an effective and reliable tool in support of management policies and controls, providing information on which an RO can act to improve its performance. Adherence to these principles is a prerequisite for providing audit conclusions that are relevant and sufficient and for enabling auditors working independently from one another to reach similar conclusions in similar circumstances.

4.2 *Audit criteria* means a set of policies, procedures or requirements.

4.3 *Audit evidence* means records, statements of fact, or other information, which are relevant to the audit criteria and verifiable. Audit evidence may be qualitative or quantitative.

4.4 *Audit findings* means results of the evaluation of the collected audit evidence against audit criteria. Audit findings can indicate conformity, observation (potential non-conformity) or non-conformity with audit criteria or opportunities for improvement.

4.5 *Audit conclusion* means an outcome of an audit, provided by the audit team, after consideration of the audit objectives and all audit findings.

4.6 *Audit client* means an organization or person requesting an audit.

4.7 *Auditee* is an organization recognized by a flag State that may be subject to an audit by the authorizing flag State.

4.8 *Auditor* means a person with the competence to conduct an audit.

4.9 *Audit team* means one or more auditors conducting an audit, supported if required by technical experts.

4.10 *Technical expert* means a person who provides specific knowledge or expertise to the audit team.

4.11 *Audit programme* means a set of one or more audits planned for a specific period and directed towards a specific purpose. An audit programme includes all activities necessary for planning, organizing, and conducting the audits.

4.12 *Audit plan* means a description of the activities and arrangements for an audit.

4.13 *Audit scope* means extent and boundaries of an audit. The audit scope generally includes a description of the physical locations, organizational units, activities and processes, as well as the time period covered.

4.14 *Competence* means demonstrated personal attributes and demonstrated ability to apply knowledge and skills.

4.15 *Oversight* means any activity by a flag State carried out to assure an RO's service complies with IMO and national requirements of the recognizing flag State.

4.16 *Monitoring* means any activity by a flag State where a flag State witnesses services by an RO or reviews documentation used by the RO and which is carried out to assure that RO services are in compliance with IMO and national requirements. Monitoring may be considered as a component of oversight.

## **5 ESTABLISHING AN OVERSIGHT PROGRAMME**

### **5.1 Oversight**

The flag State should establish or participate in an oversight programme with adequate resources for monitoring of, and communication with, its RO(s) in order to ensure that its international obligations are fully met, by:

- .1 exercising its authority to conduct supplementary surveys to ensure that ships entitled to fly its flag in fact comply with the requirements of the applicable international instruments;

- .2 conducting supplementary surveys as it deems necessary to ensure that ships entitled to fly its flag comply with national requirements, which supplement the international mandatory requirements; and
- .3 providing staff who have a good knowledge of the rules and regulations of the flag State and the ROs and who are available to carry out effective oversight of the ROs.

## **5.2 Flag State's supervision of duties delegated to an RO**

The flag State's supervision of duties delegated to an RO should consider, inter alia, the following:

- .1 documentation of the RO's quality management system;
- .2 access to internal instructions, circulars and guidelines;
- .3 access to the RO's documentation relevant to the flag State's fleet;
- .4 cooperation with the flag State's inspection and verification work; and
- .5 provision of information and statistics; such as, but not limited to, damage and casualties relevant to the flag State's fleet.

## **5.3 Verification and monitoring**

The flag State should establish a system to ensure the adequacy of statutory certification and services provided. Such a system should, inter alia, include the following items:

- .1 procedures for communication with the RO;
- .2 procedures for reporting to the flag State by the RO and the processing of such reports by the flag State. The following reporting requirements should be considered:
  - .1 the RO should notify the flag State immediately upon becoming aware of a situation involving a major deficiency, or serious safety-related issue, that would normally be considered sufficient to detain a ship from proceeding to sea pending correction;
  - .2 the RO should notify the flag State(s) immediately upon becoming aware of a situation aboard ship or within a company involving a major non-conformity, as defined in the *Guidelines on the Implementation of the International Safety Management (ISM) Code by Administrations* (resolution A.1022(26), as amended);
  - .3 the notification above should contain the name of the company or ship, the IMO number, the official number, if applicable, and a description of the major non-conformity, deficiency or issue;
  - .4 the RO should inform the flag State, as soon as possible, of any dangerous occurrences, accidents, machinery or structural breakdowns, or failures that they are aware of on a ship; and



- .5 the RO should report to the flag State in writing the names and official numbers, if applicable, of any ships removed from the RO's list of classed/certified ships for which the RO has performed statutory certification and services. The report should contain a description of the reason(s) for removal from class, and this should be made within thirty (30) days of the removal becoming effective;
- .3 additional ship's inspections by the flag State;
- .4 appropriate technical and/or safety related consultations between ROs regarding statutory certification and services, which may affect the validity of certificates issued either in whole or in part on behalf of the flag State(s);
- .5 the flag State's evaluation/acceptance of the certification of the RO's quality management system by an independent body of auditors accepted by the flag State;
- .6 monitoring and verification of statutory certification and services, which contribute either in whole or in part to compliance with a mandatory IMO instrument. The flag State should consider the implementation of the following:
  - .1 flag State's oversight of RO quality management systems;
  - .2 observation of or systematic review of reports of the quality management system audits conducted by other qualified persons or organizations external to and independent of the RO;
  - .3 verification and inspection of ships that are subject to statutory certification and services; and
  - .4 complaint and feedback system and corrective action follow-up;
- .7 a flag State accepting ships constructed without its involvement should establish that an RO conducting statutory certification and services of the ship conforms to this Code; and
- .8 for ships constructed without an identified flag State, the flag State specific requirements should be verified prior to certification.

## **6 PRINCIPLES OF AUDITING**

6.1 The flag State should be satisfied that the RO has an effective quality management system in place. The flag State may rely upon the audits carried out by an accredited certification body or equivalent organizations. Intergovernmental cooperation in establishing common auditing practices is encouraged.

6.2 A flag State auditor should advance the following principles:

- .1 ethical conduct: the foundation of professionalism. Trust, integrity, confidentiality and discretion are essential to auditing;
- .2 fair presentation: the obligation to report truthfully and accurately. Audit findings, audit conclusions, and audit reports reflect truthfully and accurately the audit activities. Significant obstacles encountered during the

audit and unresolved diverging opinions between the audit team and the auditee are reported; and

- .3 due professional care: the application of diligence and judgment in auditing. Auditors exercise care in accordance with the importance of the task they perform and the confidence placed in them by audit clients and other interested parties. Having the necessary competence is an important factor.

6.3 Further principles relate to the audit, which is by definition independent and systematic.

- .1 independence: the basis for the impartiality of the audit and objectivity of the audit conclusions. Auditors are independent of the activity being audited and are free from bias and conflict of interest. Auditors maintain an objective state of mind throughout the audit process to ensure that the audit findings and conclusions will be based only on the audit evidence;
- .2 evidence-based approach: the rational method for reaching reliable and reproducible audit conclusions in a systematic audit process. Audit evidence is verifiable. It is based on samples of the information available, since an audit is conducted during a finite period of time and with finite resources. The appropriate use of sampling is closely related to the confidence that can be placed in the audit conclusions.

6.4 The guidance given in this Code is based on the principles set out above.

## **7 MANAGING AN OVERSIGHT PROGRAMME**

### **7.1 General**

7.1.1 The flag States are required to verify that the organizations recognized to perform statutory certification and services on their behalf fulfil the requirements of this Code. The purpose of this verification is to ensure that the RO is performing its statutory certification and service in compliance with this Code and its agreement with the flag State.

7.1.2 The flag State should develop, implement, and manage an effective oversight programme of the ROs that act on its behalf.

7.1.3 An oversight programme should include various monitoring activities, which may inter alia consist of audits, inspections and audit observations (potential non-conformities). The flag States' oversight programme of their ROs should be developed after carefully assessing the factors associated with the RO as well as the extent of access to the RO's records of statutory certification and services that are made available to the flag State. The programme should also consider the delivery of statutory certification and services with respect to the provisions of the Conventions and with respect to the national requirements and instructions published by the flag State. Factors should include:

- .1 the scope and frequency of high level audits of the RO carried out by flag States and independent accredited bodies, and of internal audits carried out by the RO;
- .2 the extent to which audit findings, observations (potential non-conformities) and corrective actions are made available to the flag State;

- .3 the extent to which remote monitoring of the RO can be undertaken by the flag State which can manifest itself in several different ways depending on the scope of information that is electronically available to the flag State. Remote monitoring can include:
  - .1 review of the contents of survey reports associated with statutory certificates issued by the RO;
  - .2 review of the effectiveness of the control and rectification of deficiencies and outstanding requirements within the deadlines established by the flag State through the RO; and
  - .3 review of the RO's country-specific instructions to determine that the flag State's national requirements are properly and completely addressed by the RO;
- .4 flag State inspections carried out on board ships to check the end-result of the certification process, with a specific interest in their national requirements and/or implementation of instructions issued to the RO; and
- .5 port State control detentions and deficiencies allocated to the responsibility of the RO.

7.1.4 An oversight programme should also include all activities necessary for planning and organizing the types and number of monitoring activities, and for providing resources to conduct them effectively and efficiently within the specified periods.

7.1.5 Those assigned the responsibility for managing the oversight programme should:

- .1 establish, implement, monitor, review and improve the oversight programme; and
- .2 identify the necessary resources and ensure they are available and provided, as required.

7.1.6 An oversight programme should also include planning, the provision of resources and the establishment of procedures to conduct monitoring activities within the programme.

## **7.2 Oversight programme objectives and extent**

### **7.2.1 Objectives of an oversight programme**

7.2.1.1 The flag State should establish objectives for an oversight programme, to direct the planning and conduct of monitoring activities.

7.2.1.2 The following objectives should be considered:

- .1 management priorities;
- .2 flag State intentions;
- .3 flag State system requirements;

- .4 statutory, regulatory and contractual requirements;
- .5 need for ROs to be evaluated;
- .6 flag State, ROs, and other requirements;
- .7 needs of other interested parties; and
- .8 risks to the flag State.

## **7.2.2 Extent of an oversight programme**

7.2.2.1 The flag State's oversight programme should reflect the size, nature and complexity of the flag State's authorization programme, as well as the following factors:

- .1 the scope, objective and duration of monitoring activities to be conducted;
- .2 the frequency of monitoring activities to be conducted;
- .3 the number, importance, complexity, similarity, and locations of the ROs;
- .4 standards, statutory, regulatory, and contractual requirements and other monitoring criteria;
- .5 the need for accreditation or registration/certification of ROs;
- .6 conclusions of previous monitoring activities;
- .7 the concerns of interested parties; and
- .8 significant changes to an RO or its operations.

7.2.2.2 A flag State may enter into a written agreement to participate in combined monitoring/oversight activities with another flag State or States that have authorizations with the same RO provided that the level of detail regarding individual flag State requirements and individual flag State performance are addressed at a level equivalent to an oversight programme conducted by each of the individual flag State. Conversely no flag State may be compelled by another flag State or organization to accept oversight of an RO by others in lieu of conducting its own individual flag State oversight unless it so elects by written agreement or is so provided in the law of that State. A copy of all such agreements should be submitted to IMO for the information of the Member States.

## **7.3 Oversight programme responsibilities, resources and procedures**

### **7.3.1 Oversight programme responsibilities**

7.3.1.1 The flag State is responsible for managing its oversight programme. The flag State should utilize competent individuals that have an understanding of the oversight requirements, audit principles, and the application of audit techniques. They should have management skills as well as technical and business understanding relevant to the activities to be monitored.

7.3.1.2 Those assigned the responsibility for managing the oversight programme should:

- .1 establish the objectives and extent of the oversight programme;
- .2 establish the responsibilities and procedures, and ensure resources are provided;
- .3 ensure the implementation of the oversight programme;
- .4 ensure that appropriate oversight programme records are maintained; and
- .5 monitor, review and improve the oversight programme.

### **7.3.2 Oversight programme resources**

When identifying resources for the oversight programme, the flag State should consider the following:

- .1 financial resources necessary to develop, implement, manage, and improve oversight activities;
- .2 auditing techniques;
- .3 processes to achieve and maintain the competence of staff, and to improve oversight performance;
- .4 the availability of staff and technical experts having competence appropriate to the particular oversight programme objectives;
- .5 the extent of the oversight programme; and
- .6 travelling time, accommodation and other oversight needs.

### **7.3.3 Oversight programme procedures**

7.3.3.1 The flag State's oversight programme procedures should address the following:

- .1 planning and scheduling of oversight activities;
- .2 assuring the competence of assigned personnel;
- .3 selecting appropriate personnel and assigning their roles and responsibilities;
- .4 conducting monitoring activities;
- .5 conducting follow-up, if applicable;
- .6 maintaining oversight programme records;
- .7 monitoring the performance and effectiveness of the oversight programme; and
- .8 reporting on the overall achievements of the oversight programme.

7.3.3.2 For flag States with a limited authorization programme, the activities above may be addressed in a single procedure.

#### **7.3.4 Oversight programme implementation**

The implementation of a flag State oversight programme should include the following factors:

- .1 communicating the objectives of the oversight programme to relevant parties;
- .2 coordinating and scheduling monitoring activities relevant to the oversight programme;
- .3 establishing and maintaining a process for the evaluation of assigned personnel and their continual professional development;
- .4 selecting and appointing assigned personnel;
- .5 providing necessary resources to the oversight programme, specifically the corresponding monitoring activities;
- .6 robust execution of monitoring activities according to the oversight programme;
- .7 ensuring the control of records of the monitoring activities;
- .8 ensuring review and approval of monitoring activity reports, and ensuring their distribution to interested parties; and
- .9 ensuring follow-up, if applicable.

#### **7.3.5 Oversight programme records**

7.3.5.1 The flag State's monitoring records should be maintained to demonstrate the implementation of the oversight programme and should include the following:

- .1 all records related to monitoring activities, such as:
  - .1 plans;
  - .2 reports;
  - .3 non-conformity reports;
  - .4 corrective and preventive action reports, and
  - .5 follow-up reports, if applicable;
- .2 results of oversight programme review; and
- .3 records related to personnel covering subjects, such as:
  - .1 assigned personnel competence and performance evaluation;

- .2 monitoring and/or audit team selection; and
- .3 maintenance and improvement of competence.

7.3.5.2 Records should be retained and suitably safeguarded.

#### **7.4 Oversight programme monitoring and reviewing**

7.4.1 The implementation of a flag State oversight programme should be monitored and, at appropriate intervals, reviewed to assess whether its objectives have been met and to identify opportunities for improvement.

7.4.2 The flag State should develop and use performance indicators to monitor the effectiveness of its oversight programme for ROs. The following factors should be considered:

- .1 the ability of assigned personnel to implement the oversight plan;
- .2 conformity with the requirements of the RO Code, monitoring activities, and schedules; and
- .3 feedback from clients, ROs and assigned personnel.

7.4.3 The flag State should consider the following performance indicators when evaluating the performance of the ROs:

- .1 port State performance of ROs;
- .2 results of RO's internal audits;
- .3 results of quality management system audits performed by third-party organizations (ACBs);
- .4 the results of previous performance monitoring; and
- .5 condition/compliance of ships that receive survey and certification from the ROs.

7.4.4 The flag State should, on a periodic basis, evaluate its overall performance with respect to the implementation of administrative processes, procedures and resources necessary to meet its obligations as required by the conventions to which it is party.

7.4.5 Other measures to evaluate the performance of the flag States may include, inter alia, the following:

- .1 port State control detention rates;
- .2 flag State inspection results;
- .3 casualty statistics;
- .4 communication and information processes;
- .5 annual loss statistics (excluding constructive total losses (CTLs)); and

- .6 other performance indicators as may be appropriate, to determine whether staffing, resources and administrative procedures are adequate to meet their flag State obligations. Other performance measurement indicators may consist of the following:
  - .1 fleet loss and accident ratios to identify trends over selected time periods;
  - .2 the number of verified cases of detained ships in relation to the size of the fleet;
  - .3 the number of verified cases of incompetence or wrongdoing by individuals holding certificates or endorsements issued under its authority;
  - .4 responses to port State deficiency reports or interventions;
  - .5 investigations into very serious and serious casualties and lessons learned from them;
  - .6 technical and other resources committed;
  - .7 results of inspections, surveys and controls of the ships in the fleet;
  - .8 investigation of occupational accidents;
  - .9 the number of incidents and violations under MARPOL, as amended; and
  - .10 the number of suspensions or withdrawals of certificates, endorsements and approvals.

7.4.6 The oversight programme review should also consider:

- .1 results and trends from monitoring;
- .2 conformity with procedures;
- .3 evolving needs and expectations of interested parties;
- .4 oversight programme records;
- .5 alternative or new auditing practices or monitoring activities; and
- .6 consistency in performance between audit teams in similar situations.

7.4.7 Results of oversight programme reviews can lead to corrective and preventive actions and the improvement of the oversight programme.

\* \* \*



## Appendix 1

### REQUIREMENTS FOR TRAINING AND QUALIFICATION OF RECOGNIZED ORGANIZATION'S TECHNICAL STAFF

#### A1.1 Definitions

A1.1.1 *Survey staff* are the personnel authorized to carry out surveys and to conclude whether or not compliance has been achieved.

A1.1.2 *Plan approval staff* are the personnel authorized to carry out design assessment and to conclude whether or not compliance has been achieved.

A.1.1.3 *Audit staff* are the personnel authorized to carry out audits and to conclude whether compliance has been achieved.

A1.1.4 *Trainee* is a person receiving theoretical and practical training under the supervision of a trainer/tutor.

A1.1.5 *Trainer* is a designated person having experience within a relevant area or a proficient expert in a special field recognized by the RO to give theoretical training through classroom teaching, special seminars or individual training.

A1.1.6 *Tutor* is a qualified and designated person from among the RO's staff having appropriate experience and capability in the relevant areas of activities in which they assist, consult and supervise the practical training of a trainee until the latter is qualified.

A1.1.7 *Technical staff* are the personnel qualified to carry out technical activity as survey staff or plan approval staff or, Marine Management Systems audit staff.

A1.1.8 *Support staff* are the personnel assisting survey and/or plan approval staff in connection with classification and statutory work.

#### A1.2 Trainee entry requirements

RO personnel performing, and responsible for, statutory work shall have as a minimum the formal education requirements defined in part 2, section 4.2.5.

#### A1.3 Modules

A1.3.1 The RO shall define the required competence criteria for each relevant type of survey, and type of plan approval activity and audit to be performed.

A1.3.2 The RO shall define the necessary theoretical and practical training modules required to meet the competence criteria defined for survey, plan approval and marine management systems audit staff. The training modules shall cover as a minimum:

- .1 learning and competence objectives;
- .2 scope of training; and
- .3 evaluation criteria and pass requirements.

A1.3.3 Through studying the training modules, trainees shall acquire and develop general knowledge and understanding applicable to different types of ships and types of work according to the flag State requirements, RO's rules and regulations and international conventions and codes.

#### **A1.4 Theoretical training for survey and plan approval staff**

A1.4.1 The objective of theoretical training is to ensure that familiarization with rules, technical standards or statutory regulations and any additional requirement specific to the type of survey or ships is sufficient for the areas of activity.

A1.4.2 Theoretical training shall include:

- .1 general modules for theoretical training; and
- .2 special modules for theoretical training in the particular specialty.

A1.4.3 General modules for theoretical training shall include general subjects with respect to:

- .1 activity and functions of IMO and maritime Administrations;
- .2 activity and functions of classification societies;
- .3 classification of ships and mobile offshore drilling units;
- .4 types of certificates and reports issued on completion of class and statutory surveys;
- .5 quality management system;
- .6 personal safety regulations; and
- .7 legal and ethical issues.

A1.4.4 The programmes of theoretical training for survey and plan approval staff shall be documented in a training plan and developed according to the areas of activity (types or categories of surveys, types of ships, subjects such as hull, machinery, electrical engineering, etc.).

A1.4.5 In case of an existing gap in the formal educational background in some particular field of activity, theoretical training shall be extended.

A1.4.6 In case survey or plan approval staff have obtained particular qualifications through their previous work experience prior to their joining the RO, the training plan may be reduced.

A1.4.7 Additions or reductions in the individual training plans shall be documented.

A1.4.8 In case of extension of areas of activity the training plan shall be developed and documented accordingly.

A1.4.9 Theoretical training may be received through classroom teaching, special seminars, individual training, self-study or computer-assisted training.

**A1.5 Practical training for survey and plan approval staff (see appendix 2 for specific criteria for each certificate)**

**A1.5.1 General**

Practical training shall ensure the trainee is sufficiently proficient to carry out survey or design assessment work independently.

**A1.5.2 Plan approval staff**

A1.5.2.1 Practical training shall be commensurate with the complexity of design assessment (review of technical design of ships, review of technical documentation on materials and equipment) and shall be carried out under the supervision of a tutor.

A1.5.2.2 Practical training carried out shall be recorded.

**A1.5.3 Survey staff**

A1.5.3.1 Practical training shall be commensurate with the complexity of the survey (types or categories of surveys, types of ships, specific subjects (hull, machinery, and electrical engineering)) and shall be carried out under the supervision of a tutor.

A1.5.3.2 Selection of particular surveys depends on the specialty/qualification to be granted and shall include classification and statutory types of surveys of the following, as appropriate:

- .1 new construction;
- .2 ships and mobile offshore drilling units in operation; and
- .3 materials and equipment.

A1.5.3.3 Practical training carried out shall be recorded.

**A1.5.4 Examinations and tests for survey and plan approval staff**

A1.5.4.1 Competence gained through the theoretical training shall be demonstrated through written or oral examination or through suitable computer tests.

A1.5.4.2 Examinations and tests shall cover the sets of modules attended by the trainee, as applicable.

A1.5.4.3 With respect to competence gained through practical training being demonstrated by:

- .1 a surveyor, this shall be accomplished by the surveyor satisfactorily completing the surveys associated with the competence whilst under the supervision of the tutor. The surveyor would be expected to be able to answer associated technical questions raised as thought necessary by the tutor to confirm levels of understanding. The results of the tutor's review shall be annotated on the respective training record; and

- .2 a plan approval staff member, this shall be accomplished by the staff member satisfactorily completing the appraisal of drawings against the relevant classification rules and statutory regulations as verified through a review by the tutor of the staff member's work. The results of the tutor's review shall be annotated on the respective training record.

A1.5.4.4 A competent person shall perform examinations of theoretical training or witnessing practical competence.

A1.5.4.5 During examinations and tests, use of the relevant working documents (rules, conventions, checklists, etc.) by the trainee shall be considered allowable.

### **A1.5.5 Audit staff**

#### *A1.5.5.1 Theoretical training*

A1.5.5.1.1 Theoretical training should address the following:

- .1 principles and practice of management systems auditing;
- .2 the requirements of the International Safety Management (ISM) Code and its interpretation and application;
- .3 mandatory rules and regulations and applicable codes, guidelines and standards recommended by the IMO, flag States, classification societies and maritime industry organization; and
- .4 basic shipboard operations including emergency preparedness and response. The time spent on each topic and the level of detail that it is necessary to include will depend on the qualifications and experience of the trainees, their existing competence in each subject, and the number of training audits to be carried out.

A1.5.5.1.2 The training may be modular in structure, in which case the period over which the theoretical training is delivered shall not exceed 12 months.

A1.5.5.1.3 Where appropriate, some elements may be delivered by means such as distance learning and e-learning. However, at least fifty per cent of the total theoretical training days shall be classroom-based in order to allow for discussion and debate and to allow candidates to benefit from the experience of the trainer.

#### *A1.5.5.2 Examination*

A1.5.5.2.1 Confirmation that the learning objectives have been met shall be demonstrated by written examination at the end of the theoretical training, or at the end of each module if the training is not delivered in a single training course.

A1.5.5.2.2 If the trainee fails the written examination, or any part thereof; a single resist will be permitted. A candidate who fails the resist will be required to undergo the corresponding theoretical training again before being allowed to make another attempt at the examination.

A1.5.5.2.3 A candidate who passes a written examination shall receive a certificate, statement or other record indicating which of the competences have been addressed, and the dates on which the corresponding training took place.

### *A1.5.5.3 Practical training*

A1.5.5.3.1 A person authorized to carry out ISM audits shall have completed at least the minimum number of training audits under supervision as specified by the RO.

A1.5.5.3.2 The RO shall establish procedures for ensuring and demonstrating that the required competence has been achieved.

## **A1.6 Qualification**

A1.6.1 After completion of the theoretical and practical training, with positive results, the trainee is granted the appropriate authorizations to work independently. The activities they are qualified to perform (types of surveys, types of ships, types of design approval, etc.) are identified.

A1.6.2 The criteria adopted by the RO for granting qualifications shall be documented in the appropriate quality management system documents.

## **A1.7 Assessment of training effectiveness**

A1.7.1 The methods of training effectiveness assessment may include monitoring, testing, etc., on the regular basis according to the RO's system.

A1.7.2 The criteria adopted by the RO for training effectiveness assessment shall be documented in the appropriate RO quality management system documents.

A1.7.3 Evidence of training effectiveness assessment shall be provided.

## **A1.8 Maintenance of qualification**

A1.8.1 The criteria adopted by the RO for maintenance or updating of qualifications shall be in accordance with and documented in the appropriate RO quality management system documents.

A1.8.2 Updating of qualifications may be done through the following methods:

- .1 self-study (unassisted study);
- .2 different courses and seminars organized in local offices and/or in the main offices of the RO;
- .3 extraordinary technical seminars in case of significant changes in the RO's rules or international conventions, codes, etc. (with examination if required); and
- .4 special training on specific works or type of survey in some areas of the activity, which are determined by activity monitoring or by a long time absence of practical experience.

A1.8.3 Maintenance of qualifications in accordance with these criteria shall be verified at annual performance review.

## **A1.9 Activity monitoring**

### **A1.9.1 Purpose**

Activity monitoring has the purpose:

- .1 to assess whether the individuals are competent and capable of carrying out their authorized and assigned work independently, consistent with the RO's policies and practices;
- .2 to identify needs for continual improvement in aligning the technical services across the organization; and
- .3 to identify need for improvements in the guidance processes and/or tools provided for the staff.

### **A1.9.2 Monitoring**

A1.9.2.1 Headquarters, regional or local offices, may initiate activity monitoring. It shall be carried out by persons who are qualified in the survey or audit being monitored.

A1.9.2.2 It shall be carried out to the extent that the work of each surveyor or auditor engaged in survey or audit work will be monitored at least once every other calendar year. Where a person carries out both survey and audit work, they shall be monitored in both work activities at least once every other calendar year. Only one type of survey for a qualified surveyor and one type of audit for a qualified auditor need be monitored within the two-year cycle. Persons doing plan approval shall be monitored at least once every other calendar year.

A1.9.2.3 Subsequent to the monitoring, the monitoring surveyor or auditor shall report the activity.

A1.9.2.4 Should any comments be necessary, or findings made, these will be included in the report, for review and corrective action.

### **A1.9.3 Method**

A1.9.3.1 Activity monitoring shall be performed by personnel authorized to undertake activity monitoring.

A1.9.3.2 Preparation shall include familiarization with the processes, requirements and tools (e.g. software) associated with the activity to be witnessed during the activity monitoring.

A1.9.3.3 The monitoring process shall include a review of relevant performance information related to the individual's work. This may include: report and certificate accuracy, meeting objectives, received complaints, PSC detention feedback.

A1.9.3.4 Survey, audit or plan approval activity selected for monitoring shall have an extent such as to cover a maximum possible range of activity and qualifications that can be monitored during the attendance.

A1.9.3.5 Monitoring shall include, but not be limited to, evaluation of the individual's:

- .1 personal safety awareness;
- .2 understanding and application of the relevant requirements;
- .3 technical capabilities;
- .4 understanding of the related requirements; and
- .5 standards of reporting and communication.

#### **A1.9.4 Reporting**

Subsequent to the monitoring, a report shall be made with conclusions with respect to:

- .1 whether the individuals assessed are capable of carrying out their authorized and assigned work (including particularly positive aspects);
- .2 any areas of improvement; and
- .3 any recommended training requirements.

#### **A1.9.5 Evaluation**

The monitoring report shall be evaluated by management who will determine the individual's continued authorization or possible training requirements to obtain further authorization. The report shall be completed and reviewed annually.

#### **A1.9.6 Implementation**

The RO shall:

- .1 document the activity monitoring methodology, including how it is reported;
- .2 document how the authorization to undertake activity monitoring is achieved;
- .3 document consequence and actions to undertake if activity-monitoring timing is exceeded;
- .4 maintain records to demonstrate that all relevant staff has been monitored in the prescribed period; and
- .5 maintain records to demonstrate level of technical performance and the effect of possible improvement activities across the organization through the analysis of activity monitoring.

#### **A1.10 Training of support staff**

Support staff shall have training and/or supervision commensurate with the tasks they are authorized to perform.

### **A1.11 Records**

Records shall be maintained for each surveyor/plan approval staff member, indicating:

- .1 formal education background;
- .2 professional experience prior to joining the RO;
- .3 evidence of theoretical training completed;
- .4 evidence of practical training completed;
- .5 evidence of examinations and tests;
- .6 professional experience during employment at the RO; and
- .7 periodical updating of knowledge.

\* \* \*



## Appendix 2

### **SPECIFICATIONS ON THE SURVEY AND CERTIFICATION FUNCTIONS OF RECOGNIZED ORGANIZATIONS ACTING ON BEHALF OF THE FLAG STATE**

#### **A2.1 SCOPE**

A2.1.1 This document contains minimum specifications for organizations recognized as capable of performing statutory work on behalf of a flag State in terms of certification and survey functions connected with the issuance of international certificates.

A2.1.2 The principle of the system described below is to divide the specifications required into different elementary modules with a view to selecting the relevant modules for each function of certification and survey.

#### **A2.2 AREAS OF INTEREST COVERED BY ELEMENTARY MODULES**

- .1 Management
- .2 Technical appraisal
- .3 Surveys
- .4 Qualifications and training.

##### **A2.2.1 Management**

###### ***Module 1A: Management functions***

The management of the RO shall have the competence, capability and capacity to organize, manage and control the performance of survey and certification functions in order to verify compliance with requirements relevant to the tasks delegated and shall, inter alia:

- .1 possess an adequate number of competent supervisory, technical appraisal and survey personnel;
- .2 provide for the development and maintenance of appropriate procedures and instructions;
- .3 provide for the maintenance of up-to-date documentation on interpretation of the relevant instruments;
- .4 give technical and administrative support to field staff; and
- .5 provide for the review of survey reports and provision of experience feedback.

##### **A2.2.2 Technical appraisal**

###### ***Module 2A: Hull structure***

The RO shall have the appropriate competence, capability and capacity to perform the following technical evaluations and/or calculations pertaining to:

- .1 longitudinal strength;
- .2 local scantlings such as plates and stiffeners;
- .3 structural stress, fatigue and buckling analyses; and
- .4 materials, welding and other pertinent methods of material-joining, for compliance with relevant rules and convention requirements pertaining to design, construction and safety.

***Module 2B: Machinery systems***

The RO shall have the appropriate competence, capability and capacity to perform technical evaluations and/or calculations pertaining to:

- .1 propulsion, auxiliary machinery and steering gear;
- .2 piping; and
- .3 electrical and automation systems,

for compliance with relevant rules and convention requirements pertaining to design, construction and safety.

***Module 2C: Subdivision and stability***

The RO shall have the appropriate competence, capability and capacity to perform technical evaluations and/or calculations pertaining to:

- .1 intact and damage stability;
- .2 inclining test assessment;
- .3 grain loading stability; and
- .4 watertight and weathertight integrity.

***Module 2D: Load line***

The RO shall have the appropriate competence, capability and capacity to perform the following technical evaluations and/or calculations pertaining to:

- .1 freeboard calculation; and
- .2 conditions of assignment of freeboard.

***Module 2E: Tonnage***

The RO shall have the appropriate competence, capability and capacity to perform technical evaluations and/or calculations pertaining to tonnage computation.

**Module 2F: Structural fire protection**

The RO shall have the appropriate competence, capability, and capacity to perform technical evaluations and/or calculations pertaining to:

- .1 structural fire protection and fire isolation;
- .2 use of combustible materials;
- .3 means of escape; and
- .4 ventilation systems.

**Module 2G: Safety equipment**

The RO shall have the appropriate competence, capability and capacity to perform technical evaluations and/or calculations pertaining to:

- .1 life-saving appliances and arrangements;
- .2 navigation equipment;
- .3 fire detection and fire alarm systems and equipment;
- .4 fire-extinguishing system and equipment;
- .5 fire control plans;
- .6 pilot ladders and pilot hoists;
- .7 lights, shapes and sound signals; and
- .8 inert gas systems.

**Module 2H: Oil pollution prevention**

The RO shall have the appropriate competence, capability and capacity to perform technical evaluations and/or calculations pertaining to:

- .1 monitoring and control of oil discharge;
- .2 segregation of oil and ballast water;
- .3 crude oil washing;
- .4 protective location of segregated ballast spaces;
- .5 pumping, piping and discharge arrangements; and
- .6 shipboard oil pollution emergency plans (SOPEPs).

### ***Module 2I: NLS pollution prevention***

The RO shall have the appropriate competence, capability and capacity to perform technical evaluations and/or calculations pertaining to:

- .1 list of substances the ship may carry;
- .2 pumping system;
- .3 stripping system;
- .4 tank-washing system and equipment; and
- .5 underwater discharge arrangements.

### **Module 2J: Radio**

The RO shall have the appropriate competence, capability and capacity to perform technical evaluations pertaining to:

- .1 radiotelephony;
- .2 radiotelegraphy; and
- .3 GMDSS.

Alternatively, a professional radio installation inspection service company approved and monitored by the RO according to an established and documented programme may perform these services. This programme is to include the definition of the specific requirements the company and its radio technicians shall satisfy.

### ***Module 2K: Carriage of dangerous chemicals in bulk***

The RO shall have the appropriate competence, capability and capacity to perform technical evaluations and/or calculations pertaining to:

- .1 ship arrangement and ship survival capacity;
- .2 cargo containment and material of construction;
- .3 cargo temperature control and cargo transfer;
- .4 cargo tank vent systems and environmental control;
- .5 personnel protection; operational requirements; and
- .6 list of chemicals the ship may carry.

### ***Module 2L: Carriage of liquefied gases in bulk***

The RO shall have the appropriate competence, capability and capacity to perform technical evaluations and/or calculations pertaining to:

- .1 ship arrangement and ship survival capacity;
- .2 cargo containment and material of construction;
- .3 process pressure vessels and liquid, vapour and pressure piping systems;
- .4 cargo tank vent systems and environmental control;
- .5 personnel protection;
- .6 use of cargo as fuel; and
- .7 operational requirements.

#### **A2.2.3 Surveys**

##### ***Module 3A: Survey functions***

The RO shall have the appropriate competence, capability and capacity to perform the required surveys under controlled conditions as per the RO's internal quality management system and, representing an adequate geographical coverage and local representation as required. The work to be covered by the staff is described in the relevant sections of the appropriate survey guidelines developed by the Organization.

#### **A2.2.4 Qualifications and training**

##### ***Module 4A: General qualifications***

RO personnel performing, and responsible for, statutory work shall meet, as a minimum, the requirements defined in part 2, section 4.2.5.

##### ***Module 4B: Radio survey qualifications***

A professional radio installation inspection service company, approved and monitored by the RO according to an established and documented programme, may do surveys. This programme is to include the definition of the specific requirements the company and its radio technicians shall satisfy, including, inter alia, requirements for internal tutored training covering at least:

- .1 radiotelephony;
- .2 radiotelegraphy;
- .3 GMDSS; and
- .4 initial and renewal surveys.

Radio technicians carrying out surveys shall have successfully completed, as a minimum, at least one year of relevant technical school training, the internal tutored training programme of his/her employer and at least one year of experience as an assistant radio technician. For exclusive radio surveyors to the RO, equivalent requirements as above apply.

## **A2.3 SPECIFICATIONS PERTAINING TO THE VARIOUS CERTIFICATES**

### **A2.3.1 Passenger ship safety certificate**

#### ***Initial certification, renewal survey***

A2.3.1.1 Module Nos. 1A, 2A, 2B, 2C, 2D, 2F, 2G, 2J, 3A, 4A and 4B apply.

A2.3.1.2 For this certification, the system shall cover practical tutored training on the following issues as appropriate for Technical Appraisal and Support staff (TS) and Field Surveyors (FS), respectively:

- .1 TS: SOLAS 74, as amended.
- .2 FS: SOLAS 74, as amended:
  - .1 initial survey, report, and issuance of certificate; and
  - .2 renewal survey, report- and issuance of certificate.

### **A2.3.2 Cargo ship safety construction certificate**

#### ***Initial certification, annual/intermediate, renewal surveys***

A2.3.2.1 Module Nos. 1A, 2A, 2B, 2C, 2F, 3A and 4A apply.

A2.3.2.2 For this certification the system shall cover practical tutored training on the following issues as appropriate for Technical Appraisal and Support staff (TS) and Field Surveyors (FS), respectively:

- .1 TS: SOLAS 74 chapters II-1, II-2 and XII with any amendments and appropriate classification rules.
- .2 FS: Pertinent technical surveys (class surveys or similar), newbuilding:
  - .1 hull structure and equipment; and
  - .2 machinery and systems installation and testing.
- .3 FS: Pertinent technical surveys (class surveys or similar), ships in operation:
  - .1 annual/intermediate survey;
  - .2 renewal survey; and
  - .3 bottom survey.
- .4 FS: SOLAS 74 chapters II-1, II-2 and XII, as amended:
  - .1 initial survey, report, issuance of certificate;
  - .2 annual/intermediate survey and report; and
  - .3 renewal survey, report and issuance of certificate.

### **A2.3.3 Cargo ship safety equipment certificate**

#### ***Initial certification, annual, periodical, renewal surveys***

A2.3.3.1 Module Nos. 1A, 2G, 3A and 4A apply.

A2.3.3.2 For this certification the system shall cover practical tutored training on the following issues as appropriate for Technical Appraisal and Support staff (TS) and Field Surveyors (FS), respectively:

- .1 TS: SOLAS 74 chapters II-1, II-2, III and V, as amended, and applicable aspects of COLREG 72, as amended.
- .2 FS: SOLAS 74 chapters II-1, II-2, III and V, as amended, and applicable aspects of COLREG 72, as amended:
  - .1 initial survey, report and issuance of certificate;
  - .2 annual/periodical survey and report; and
  - .3 renewal survey, report and issuance of certificate.

### **A2.3.4 Cargo ship safety radio certificate**

#### ***Initial certification, periodical, renewal surveys***

A2.3.4.1 Module Nos. 1A, 2J, 3A and 4B apply.

A2.3.4.2 For this certification the system shall cover practical tutored training on the following issues for Technical Appraisal and Support staff (TS) and Field Surveyors (FS) respectively:

- .1 TS: SOLAS 74 chapter IV, as amended.
- .2 FS: Reference Module 4B.

### **A2.3.5 International Safety Management Code certification**

#### ***Initial certification, annual/intermediate verifications, renewal certification***

A2.3.5.1 All of the modules, with the exception of 2E (tonnage), apply to the extent that they relate to an RO's ability to identify and evaluate the mandatory rules and regulations with which a company's safety management system and ships shall comply.

A2.3.5.2 For this certification, the system shall comply with the qualification and training requirements for ISM Code assessors contained in the *Guidelines on Implementation of the International Safety Management (ISM) Code by Administrations*.

### **A2.3.6 International load line certificate**

#### ***Initial certification, annual, renewal surveys***

A2.3.6.1 Module Nos. 1A, 2A, 2C, 2D, 3A and 4A apply.

A2.3.6.2 For this certification, the system shall cover practical tutored training on the following issues as appropriate for Technical Appraisal and Support staff (TS) and Field Surveyors (FS), respectively:

- .1 TS: Calculation of freeboard and approval of drawings for conditions of assignment according to ILLC 1966.
- .2 FS: Pertinent technical surveys (class surveys or similar), newbuilding:
  - .1 hull structural survey;
  - .2 hull penetrations and closing appliances; and
  - .3 stability/inclining test.
- .3 FS: Pertinent technical surveys (class surveys or similar), ships in operation:
  - .1 annual survey;
  - .2 renewal survey; and
  - .3 bottom survey.
- .4 FS: Measurement for load line/initial survey report.
- .5 FS: Conditions for assignment/initial survey report.
- .6 FS: Load line marking verification/initial survey report.
- .7 FS: Load line annual survey.
- .8 FS: Load line renewal survey, report and issuance of certificate.

### **A2.3.7 International oil pollution prevention certificate**

#### ***Initial certification, annual, intermediate, renewal surveys***

A2.3.7.1 Module Nos. 1A, 2A, 2B, 2C, 2H, 3A and 4A apply.

A2.3.7.2 For this certification, the system shall cover practical tutored training on the following issues as appropriate for Technical Appraisal and Support staff (TS) and Field Surveyors (FS), respectively:

- .1 TS: Approval of drawings and manuals according to MARPOL, Annex I.
- .2 FS: MARPOL, Annex I, as amended:
  - .1 initial survey, report and issuance of certificate;
  - .2 annual/intermediate survey and report; and
  - .3 renewal survey, report and issuance of certificate.



### **A2.3.8 International pollution prevention certificate for the carriage of noxious liquid substances in bulk**

#### ***Initial certification, annual, intermediate, renewal surveys***

A2.3.8.1 Module Nos. 1A, 2A, 2B, 2C, 2I, 3A and 4A apply.

A2.3.8.2 For this certification the system shall cover practical tutored training on the following issues as appropriate for Technical Appraisal and Support staff (TS) and Field Surveyors (FS), respectively:

- .1 TS: Approval of drawings and manuals according to MARPOL, Annex II and appropriate codes.
- .2 FS: MARPOL, Annex II and appropriate codes:
  - .1 initial survey, report and issuance of certificate;
  - .2 annual/intermediate survey and report; and
  - .3 renewal survey, report and issuance of certificate.

### **A2.3.9 International certificate of fitness for the carriage of dangerous chemicals in bulk**

#### ***Initial certification, annual, intermediate, renewal surveys***

A2.3.9.1 Module Nos. 1A, 2A, 2B, 2C, 2K, 3A and 4A apply.

A2.3.9.2 For this certification the system shall cover practical tutored training on the following issues as appropriate for Technical Appraisal and Support staff (TS) and Field Surveyors (FS), respectively:

- .1 TS: Approval of drawings and manuals according to International Code for the Construction and Equipment of Ships Carrying Dangerous Chemicals in Bulk (IBC Code).
- .2 FS: IBC Code:
  - .1 initial survey, report and issuance of certificate;
  - .2 annual/intermediate survey and report; and
  - .3 renewal survey, report and issuance of certificate.

### **A2.3.10 International certificate of fitness for the carriage of liquefied gases in bulk**

#### ***Initial certification, annual, intermediate, renewal surveys***

A2.3.10.1 Module Nos. 1A, 2A, 2B, 2C, 2L, 3A and 4A apply.

A2.3.10.2 For this certification the system shall cover practical tutored training on the following issues as appropriate for Technical Appraisal and Support staff (TS) and Field Surveyors (FS), respectively:

- .1 TS: Approval of drawings and manuals according to International Code for the Construction and Equipment of Ships Carrying Liquefied Gases in Bulk (IGC Code).
- .2 FS: IGC Code:
  - .1 initial survey, report and issuance of certificate;
  - .2 annual/intermediate survey and report; and
  - .3 renewal survey, report and issuance of certificate.

### **A2.3.11 International tonnage certificate (1969)**

#### ***Initial certification***

A2.3.11.1 Module Nos. 1A, 2E and 4A apply.

A2.3.11.2 For this certification the system shall cover practical tutored training on the following issues as appropriate for Technical Appraisal and Support staff (TS) and Field Surveyors (FS), respectively:

- .1 TS: Measurement and computation of tonnage according to:
  - .1 1969 Tonnage Measurement Convention; and
  - .2 Pertinent IMO resolutions.
- .2 FS: Marking survey and report.

\* \* \*

### Appendix 3

#### ELEMENTS TO BE INCLUDED IN AN AGREEMENT

A formal written agreement or equivalent between the flag State and the RO should, as a minimum, cover the following items:

- 1 Application
- 2 Purpose
- 3 General conditions
- 4 The execution of functions under authorization:
  - .1 Functions in accordance with the general authorization
  - .2 Functions in accordance with special (additional) authorization
  - .3 Relationship between the organization's statutory and other related activities
  - .4 Functions to cooperate with port States to facilitate the rectification of reported port State control deficiencies or the discrepancies within the organization's purview
- 5 Legal basis of the functions under authorization:
  - .1 Acts, regulations and supplementary provisions
  - .2 Interpretations
  - .3 Deviations and equivalent solutions
- 6 Reporting to the flag State:
  - .1 Procedures for reporting in the case of general authorization
  - .2 Procedures for reporting in the case of special authorization
  - .3 Reporting on classification of ships (assignment of class, alterations and cancellations), as applicable
  - .4 Reporting of cases where a ship did not in all respects remain fit to proceed to sea without danger to the ship or persons on board or presenting unreasonable threat of harm to the environment
  - .5 Other reporting

- 7 Development of rules and/or regulations – Information:
  - .1 Cooperation in connection with development of rules and/or regulations – liaison meetings
  - .2 Exchange of rules and/or regulations and information
  - .3 Language and form
- 8 Other conditions:
  - .1 Remuneration
  - .2 Rules for administrative proceedings
  - .3 Confidentiality
  - .4 Liability<sup>3</sup>
  - .5 Financial responsibility
  - .6 Entry into force
  - .7 Termination
  - .8 Breach of agreement
  - .9 Settlement of disputes
  - .10 Use of subcontractors
  - .11 Issue of the agreement
  - .12 Amendments
- 9 Specification of the authorization from the flag State to the organization:
  - .1 Ship types and sizes
  - .2 Conventions and other instruments, including relevant national legislation
  - .3 Approval of drawings
  - .4 Approval of material and equipment
  - .5 Surveys

---

<sup>3</sup> ROs and its employees who are involved in or responsible for delivery of statutory certification and services may be required by the law of the flag State to be covered by professional indemnity or professional liability insurance in the event that liability is finally and definitively imposed on the flag State for loss or damage which is proved in a court of law to have been caused by any negligent act or omission by its RO. In this connection, the flag State may also consider placing a limitation on the level of liability and indemnification to be covered under that insurance or other compensation arrangements.

- .6 Issuance of certificates
  - .7 Corrective actions
  - .8 Withdrawal of certificates
  - .9 Reporting
- 10 The flag State's supervision of duties delegated to the organization:
- .1 Documentation of quality assurance system
  - .2 Access to internal instructions, circulars and guidelines
  - .3 Access by the flag State to the organization's documentation relevant to the flag State's fleet
  - .4 Cooperation with the flag State's inspection and verification work
  - .5 Provision of information and statistics on, e.g. damage and casualties relevant to the flag State's fleet.

\*\*\*



**ANNEX 2**

**RESOLUTION MSC.350(92)  
(Adopted on 21 June 2013)**

**AMENDMENTS TO THE INTERNATIONAL CONVENTION  
FOR THE SAFETY OF LIFE AT SEA, 1974, AS AMENDED**

THE MARITIME SAFETY COMMITTEE,

RECALLING Article 28(b) of the Convention on the International Maritime Organization concerning the functions of the Committee,

RECALLING ALSO article VIII(b) of the International Convention for the Safety of Life at Sea (SOLAS), 1974 (hereinafter referred to as "the Convention"), concerning the amendment procedure applicable to the annex to the Convention, other than to the provisions of chapter I thereof,

HAVING CONSIDERED, at its ninety-second session, amendments to the Convention, proposed and circulated in accordance with article VIII(b)(i) thereof,

1. ADOPTS, in accordance with article VIII(b)(iv) of the Convention, amendments to the Convention, the text of which is set out in the annex to the present resolution;
2. DETERMINES, in accordance with article VIII(b)(vi)(2)(bb) of the Convention, that the said amendments shall be deemed to have been accepted on 1 July 2014, unless, prior to that date, more than one third of the Contracting Governments to the Convention or Contracting Governments the combined merchant fleets of which constitute not less than 50 per cent of the gross tonnage of the world's merchant fleet, have notified their objections to the amendments;
3. INVITES SOLAS Contracting Governments to note that, in accordance with article VIII(b)(vii)(2) of the Convention, the amendments shall enter into force on 1 January 2015 upon their acceptance in accordance with paragraph 2 above;
4. REQUESTS the Secretary-General, in conformity with article VIII(b)(v) of the Convention, to transmit certified copies of the present resolution and the text of the amendments contained in the annex to all Contracting Governments to the Convention;
5. ALSO REQUESTS the Secretary-General to transmit copies of this resolution and its annex to Members of the Organization which are not Contracting Governments to the Convention.

\* \* \*

ANNEX

**AMENDMENTS TO THE INTERNATIONAL CONVENTION FOR  
THE SAFETY OF LIFE AT SEA, 1974, AS AMENDED**

**CHAPTER III  
LIFE-SAVING APPLIANCES AND ARRANGEMENTS**

**Part B  
Requirements for ships and life-saving appliances**

**Regulation 19 – Emergency training and drills**

1 The existing text of paragraphs 2.2 and 2.3 is replaced with the following:

"2.2 On a ship engaged on a voyage where passengers are scheduled to be on board for more than 24 h, musters of newly-embarked passengers shall take place prior to or immediately upon departure. Passengers shall be instructed in the use of the lifejackets and the action to take in an emergency.

2.3 Whenever new passengers embark, a passenger safety briefing shall be given immediately before departure, or immediately after departure. The briefing shall include the instructions required by regulations 8.2 and 8.4, and shall be made by means of an announcement, in one or more languages likely to be understood by the passengers. The announcement shall be made on the ship's public address system, or by other equivalent means likely to be heard at least by the passengers who have not yet heard it during the voyage. The briefing may be included in the muster required by paragraph 2.2. Information cards or posters or video programmes displayed on ships video displays may be used to supplement the briefing, but may not be used to replace the announcement."

2 After existing paragraph 3.2, a new paragraph 3.3 is inserted as follows:

"3.3 Crew members with enclosed space entry or rescue responsibilities shall participate in an enclosed space entry and rescue drill to be held on board the ship at least once every two months."

3 Existing sections 3.3 and 3.4 are renumbered as 3.4 and 3.5, respectively. In the renumbered paragraph 3.4.2, the reference "paragraph 3.3.1.5" is replaced by the reference "paragraph 3.4.1.5"; and in the renumbered paragraph 3.4.3, the reference "paragraphs 3.3.4 and 3.3.5" is replaced by the reference "paragraphs 3.4.4 and 3.4.5"

4 After the renumbered section 3.5, the following new section is added:

"3.6 Enclosed space entry and rescue drills

3.6.1 Enclosed space entry and rescue drills should be planned and conducted in a safe manner, taking into account, as appropriate, the guidance provided in the recommendations developed by the Organization\*.

---

\* Refer to the *Revised Recommendations for entering enclosed spaces aboard ships*, adopted by the Organization by resolution A.1050(27).



3.6.2 Each enclosed space entry and rescue drill shall include:

- .1 checking and use of personal protective equipment required for entry;
- .2 checking and use of communication equipment and procedures;
- .3 checking and use of instruments for measuring the atmosphere in enclosed spaces;
- .4 checking and use of rescue equipment and procedures; and
- .5 instructions in first aid and resuscitation techniques."

5 In paragraph 4.2, at the end of subparagraph .3, the word "and" is deleted; at the end of subparagraph .4, the period "." is replaced by the word "; and"; and after subparagraph .4, the following new subparagraph is added:

- "5 risks associated with enclosed spaces and onboard procedures for safe entry into such spaces which should take into account, as appropriate, the guidance provided in recommendations developed by the Organization .

---

\* Refer to the *Revised Recommendations for entering enclosed spaces aboard ships*, adopted by the Organization by resolution A.1050(27)."

6 In paragraph 5, after the words "fire drills,", the words "enclosed space entry and rescue drills," are inserted.

## CHAPTER V SAFETY OF NAVIGATION

### **Regulation 19 – Carriage requirements for shipborne navigational systems and equipment**

7 In subparagraph 1.2.1, the words "1.2.2 and 1.2.3" are replaced with the words "1.2.2, 1.2.3 and 1.2.4".

8 In subparagraph 1.2.2, the word "and" at the end of the subparagraph is deleted and in subparagraph 1.2.3, the full stop "." is replaced with the word "; and".

9 After the existing subparagraph 1.2.3, the following new subparagraph is added:

- "4 be fitted with the system required in paragraph 2.2.3, as follows:
- .1 passenger ships irrespective of size, not later than the first survey\* after 1 January 2016;
  - .2 cargo ships of 3,000 gross tonnage and upwards, not later than the first survey\* after 1 January 2016;
  - .3 cargo ships of 500 gross tonnage and upwards but less than 3,000 gross tonnage, not later than the first survey\* after 1 January 2017; and

- .4 cargo ships of 150 gross tonnage and upwards but less than 500 gross tonnage, not later than the first survey after 1 January 2018.

The bridge navigational watch alarm system shall be in operation whenever the ship is underway at sea.

The provisions of paragraph 2.2.4 shall also apply to ships constructed before 1 July 2002.

---

\* Refer to the Unified interpretation of the term first survey referred to in SOLAS regulations (MSC.1/Circ.1290)."

- 10 After the new subparagraph 1.2.4, the following new paragraph is added:

"1.3 Administrations may exempt ships from the application of the requirement of paragraph 1.2.4 when such ships will be taken permanently out of service within two years after the implementation date specified in subparagraphs 1.2.4.1 to 1.2.4.4."

## **CHAPTER XI-1 SPECIAL MEASURES TO ENHANCE MARITIME SAFETY**

### **Regulation 1 – Authorization of recognized organizations**

- 11 The existing text of regulation 1 is replaced with the following:

"The Administration shall authorize organizations, referred to in regulation I/6, including classification societies, in accordance with the provisions of the present Convention and with the Code for Recognized Organizations (RO Code), consisting of part 1 and part 2 (the provisions of which shall be treated as mandatory) and part 3 (the provisions of which shall be treated as recommendatory), as adopted by the Organization by resolution MSC.349(92), as may be amended by the Organization, provided that:

- (a) amendments to part 1 and part 2 of the RO Code are adopted, brought into force and take effect in accordance with the provisions of article VIII of the present Convention;
- (b) amendments to part 3 of the RO Code are adopted by the Maritime Safety Committee in accordance with its Rules of Procedure; and
- (c) any amendments adopted by the Maritime Safety Committee and the Marine Environment Protection Committee are identical and come into force or take effect at the same time, as appropriate."

\*\*\*

**ANNEX 3**

**RESOLUTION MSC.351(92)  
(Adopted on 21 June 2013)**

**AMENDMENTS TO THE INTERNATIONAL CODE OF SAFETY  
FOR HIGH-SPEED CRAFT, 1994 (1994 HSC CODE)**

THE MARITIME SAFETY COMMITTEE,

RECALLING Article 28(b) of the Convention on the International Maritime Organization concerning the functions of the Committee,

NOTING resolution MSC.36(63), by which it adopted the *International Code of Safety for High-Speed Craft* (hereinafter referred to as "the 1994 HSC Code"), which has become mandatory under chapter X of the International Convention for the Safety of Life at Sea (SOLAS), 1974 (hereinafter referred to as "the Convention"),

NOTING ALSO article VIII(b) and regulation X/1.1 of the Convention concerning the procedure for amending the 1994 HSC Code,

HAVING CONSIDERED, at its ninety-second session, amendments to the 1994 HSC Code proposed and circulated in accordance with article VIII(b)(i) of the Convention,

1. ADOPTS, in accordance with article VIII(b)(iv) of the Convention, amendments to the International Code of Safety for High-Speed Craft (1994 HSC Code), the text of which is set out in the annex to the present resolution;
2. DETERMINES, in accordance with article VIII(b)(vi)(2)(bb) of the Convention, that the amendments shall be deemed to have been accepted on 1 July 2014 unless, prior to that date, more than one third of the Contracting Governments to the Convention or Contracting Governments the combined merchant fleets of which constitute not less than 50 per cent of the gross tonnage of the world's merchant fleet, have notified their objections to the amendments;
3. INVITES Contracting Governments to note that, in accordance with article VIII(b)(vii)(2) of the Convention, the amendments shall enter into force on 1 January 2015 upon their acceptance in accordance with paragraph 2 above;
4. REQUESTS the Secretary-General, in conformity with article VIII(b)(v) of the Convention, to transmit certified copies of the present resolution and the text of the amendments contained in the annex to all Contracting Governments to the Convention;
5. ALSO REQUESTS the Secretary-General to transmit copies of this resolution and its annex to Members of the Organization, which are not Contracting Governments to the Convention.

\* \* \*

ANNEX

**AMENDMENTS TO THE THE INTERNATIONAL CODE OF SAFETY  
FOR HIGH-SPEED CRAFT, 1994 (1994 HSC CODE)**

**CHAPTER 18  
OPERATIONAL REQUIREMENTS**

- 1 After existing paragraph 18.5.3, a new paragraph is inserted as follows:
- "18.5.4 Crew members with enclosed space entry or rescue responsibilities should participate in an enclosed space entry and rescue drill, to be held on board the craft, at least once every two months."
- 2 The existing paragraphs 18.5.4 to 18.5.10 are renumbered as 18.5.5 to 18.5.11, respectively.
- 3 The first sentence of the renumbered paragraph 18.5.8 is amended to read:
- "18.5.8 Records
- The date when musters are held, details of abandon craft drills and fire drills, drills of other life-saving appliances, enclosed space entry and rescue drills, and onboard training should be recorded in such logbook as may be prescribed by the Administration."
- 4 After renumbered paragraph 18.5.11, a new subsection is inserted as follows:
- "18.5.12 Enclosed space entry and rescue drills
- 18.5.12.1 Enclosed space entry and rescue drills should be planned and conducted in a safe manner, taking into account, as appropriate, the guidance provided in the recommendations developed by the Organization<sup>\*</sup>.
- 
- <sup>\*</sup> Refer to the *Revised Recommendations for entering enclosed spaces aboard ships*, adopted by the Organization by resolution A.1050(27).
- 18.5.12.2 Each enclosed space entry and rescue drill should include:
- .1 checking and use of personal protective equipment required for entry;
  - .2 checking and use of communication equipment and procedures;
  - .3 checking and use of instruments for measuring the atmosphere in enclosed spaces;
  - .4 checking and use of rescue equipment and procedures; and
  - .5 instructions in first aid and resuscitation techniques.
- 18.5.12.3 The risks associated with enclosed spaces and onboard procedures for safe entry into such spaces which should take into account, as appropriate, the guidance provided in recommendations developed by the Organization<sup>\*</sup>.
- 
- <sup>\*</sup> Refer to the *Revised Recommendations for entering enclosed spaces aboard ships*, adopted by the Organization by resolution A.1050(27)."

\*\*\*

**ANNEX 4**

**RESOLUTION MSC.352(92)  
(adopted on 21 June 2013)**

**AMENDMENTS TO THE INTERNATIONAL CODE OF SAFETY  
FOR HIGH-SPEED CRAFT, 2000 (2000 HSC CODE)**

THE MARITIME SAFETY COMMITTEE,

RECALLING Article 28(b) of the Convention on the International Maritime Organization concerning the functions of the Committee,

NOTING resolution MSC.97(73), by which it adopted the *International Code of Safety for High-Speed Craft, 2000* (hereinafter referred to as "the 2000 HSC Code"), which has become mandatory under chapter X of the International Convention for the Safety of Life at Sea (SOLAS), 1974 (hereinafter referred to as "the Convention"),

NOTING ALSO article VIII(b) and regulation X/1.2 of the Convention concerning the procedure for amending the 2000 HSC Code,

HAVING CONSIDERED, at its ninety-second session, amendments to the 2000 HSC Code proposed and circulated in accordance with article VIII(b)(i) of the Convention,

1. ADOPTS, in accordance with article VIII(b)(iv) of the Convention, amendments to the 2000 HSC Code, the text of which is set out in the annex to the present resolution;
2. DETERMINES, in accordance with article VIII(b)(vi)(2)(bb) of the Convention, that the amendments shall be deemed to have been accepted on 1 July 2014 unless, prior to that date, more than one third of the Contracting Governments to the Convention or Contracting Governments the combined merchant fleets of which constitute not less than 50 per cent of the gross tonnage of the world's merchant fleet, have notified their objections to the amendments;
3. INVITES Contracting Governments to the Convention to note that, in accordance with article VIII(b)(vii)(2) of the Convention, the amendments shall enter into force on 1 January 2015 upon their acceptance in accordance with paragraph 2 above;
4. REQUESTS the Secretary-General, in conformity with article VIII(b)(v) of the Convention, to transmit certified copies of the present resolution and the text of the amendments contained in the annex to all Contracting Governments to the Convention;
5. ALSO REQUESTS the Secretary-General to transmit copies of this resolution and its annex to Members of the Organization, which are not Contracting Governments to the Convention.

\* \* \*

ANNEX

**AMENDMENTS TO THE INTERNATIONAL CODE OF SAFETY  
FOR HIGH-SPEED CRAFT, 2000 (2000 HSC CODE)**

**CHAPTER 18  
OPERATIONAL REQUIREMENTS**

- 1 After existing paragraph 18.5.3, a new paragraph is inserted as follows:
- "18.5.4 Crew members with enclosed space entry or rescue responsibilities shall participate in an enclosed space entry and rescue drill, to be held on board the craft, at least once every two months."
- 2 The existing paragraphs 18.5.4 to 18.5.10 are renumbered as 18.5.5 to 18.5.11, respectively.
- 3 The first sentence of the renumbered paragraph 18.5.8.1 is amended to read:
- "18.5.8.1 The date when musters are held, details of abandon craft drills and fire drills, drills of other life-saving appliances, enclosed space entry and rescue drills, and onboard training shall be recorded in such log-book as may be prescribed by the Administration."
- 4 After renumbered paragraph 18.5.11, a new subsection is inserted as follows:
- "18.5.12 Enclosed space entry and rescue drills
- 18.5.12.1 Enclosed space entry and rescue drills should be planned and conducted in a safe manner, taking into account, as appropriate, the guidance provided in the recommendations developed by the Organization\*.
- \* Refer to the *Revised Recommendations for entering enclosed spaces aboard ships*, adopted by the Organization by resolution A.1050(27).
- 18.5.12.2 Each enclosed space entry and rescue drill shall include:
- .1 checking and use of personal protective equipment required for entry;
  - .2 checking and use of communication equipment and procedures;
  - .3 checking and use of instruments for measuring the atmosphere in enclosed spaces;
  - .4 checking and use of rescue equipment and procedures; and
  - .5 instructions in first aid and resuscitation techniques.
- 18.5.12.3 The risks associated with enclosed spaces and onboard procedures for safe entry into such spaces which should take into account, as appropriate, the guidance provided in recommendations developed by the Organization .

---

\* Refer to the *Revised Recommendations for entering enclosed spaces aboard ships*, adopted by the Organization by resolution A.1050(27)."

\*\*\*

**ANNEX 5**

**RESOLUTION MSC.353(92)  
(Adopted on 21 June 2013)**

**AMENDMENTS TO THE INTERNATIONAL MANAGEMENT CODE FOR THE  
SAFE OPERATION OF SHIPS AND FOR POLLUTION PREVENTION  
(INTERNATIONAL SAFETY MANAGEMENT (ISM) CODE)**

THE MARITIME SAFETY COMMITTEE,

RECALLING Article 28(b) of the Convention on the International Maritime Organization concerning the functions of the Committee,

NOTING resolution A.741(18), by which the Assembly adopted the *International Management Code for the Safe Operation of Ships and for Pollution Prevention (International Safety Management (ISM) Code)* (hereinafter referred to as "the ISM Code"), which has become mandatory under chapter IX of the International Convention for the Safety of Life at Sea (SOLAS), 1974 (hereinafter referred to as "the Convention"),

NOTING ALSO article VIII(b) and regulation IX/1.1 of the Convention concerning the procedure for amending the ISM Code,

HAVING CONSIDERED, at its ninety-second session, amendments to the ISM Code proposed and circulated in accordance with article VIII(b)(i) of the Convention,

1. ADOPTS, in accordance with article VIII(b)(iv) of the Convention, amendments to the ISM Code, the text of which is set out in the annex to the present resolution;
2. DETERMINES, in accordance with article VIII(b)(vi)(2)(bb) of the Convention, that the amendments shall be deemed to have been accepted on 1 July 2014 unless, prior to that date, more than one third of the Contracting Governments to the Convention or Contracting Governments the combined merchant fleets of which constitute not less than 50 per cent of the gross tonnage of the world's merchant fleet, have notified their objections to the amendments;
3. INVITES Contracting Governments to note that, in accordance with article VIII(b)(vii)(2) of the Convention, the amendments shall enter into force on 1 January 2015 upon their acceptance in accordance with paragraph 2 above;
4. REQUESTS the Secretary-General, in conformity with article VIII(b)(v) of the Convention, to transmit certified copies of the present resolution and the text of the amendments contained in the annex to all Contracting Governments to the Convention;
5. ALSO REQUESTS the Secretary-General to transmit copies of this resolution and its annex to Members of the Organization, which are not Contracting Governments to the Convention.

\* \* \*

ANNEX

**AMENDMENTS TO THE INTERNATIONAL MANAGEMENT CODE  
FOR THE SAFE OPERATION OF SHIPS AND FOR POLLUTION PREVENTION  
(INTERNATIONAL SAFETY MANAGEMENT (ISM) CODE)**

**PART A – IMPLEMENTATION**

**6 RESOURCES AND PERSONNEL**

1 The existing text of paragraph 6.2 is replaced with the following:

"6.2 The Company should ensure that each ship is:

- .1 manned with qualified, certificated and medically fit seafarers in accordance with national and international requirements; and
- .2 appropriately manned in order to encompass all aspects of maintaining safe operations on board\*.

\* Refer to the *Principles of minimum safe manning*, adopted by the Organization by resolution A.1047(27)."

**12 COMPANY VERIFICATION, REVIEW AND EVALUATION**

2 The following new paragraph 12.2 is inserted after existing paragraph 12.1 and the existing paragraphs 12.2 to 12.6 are renumbered as 12.3 to 12.7:

"12.2 The Company should periodically verify whether all those undertaking delegated ISM-related tasks are acting in conformity with the Company's responsibilities under the Code."

**Footnotes and paragraph for foreword of the publication of the Code**

1 In paragraph 1.1.10, the following footnote is added after the words "Major non-conformity":

"Refer to the *Procedures concerning observed ISM Code major non-conformities* (MSC/Circ.1059-MEPC/Circ.401)."

2 In paragraph 1.2.3.2, the following footnote is added after the word "account":

"Refer to the *List of codes, recommendations, guidelines and other safety and security-related non-mandatory instruments* (MSC.1/Circ.1371)."

3 The following footnote is added at the end of the title of section 3:

"Refer to the *Guidelines for the operational implementation of the International Safety Management (ISM) Code by Companies* (MSC-MEPC.7/Circ.5)."

4 The following footnote is added at the end of the title of section 4:

"Refer to the *Guidance on the qualifications, training and experience necessary for undertaking the role of the Designated Person under the provisions of the International Safety Management (ISM) Code* (MSC-MEPC.7/Circ.6)."







**ANNEX 6**

**RESOLUTION MSC.354(92)  
(Adopted on 21 June 2013)**

**AMENDMENTS TO THE INTERNATIONAL MARITIME  
SOLID BULK CARGOES (IMSBC) CODE**

THE MARITIME SAFETY COMMITTEE,

RECALLING Article 28(b) of the Convention on the International Maritime Organization concerning the functions of the Committee,

NOTING resolution MSC.268(85) by which it adopted the *International Maritime Solid Bulk Cargoes Code* (hereinafter referred to as "the IMSBC Code"), which has become mandatory under chapters VI and VII of the International Convention for the Safety of Life at Sea (SOLAS), 1974 (hereinafter referred to as "the Convention"),

NOTING ALSO article VIII(b) and regulation VI/1-1.1 of the Convention concerning the amendment procedure for amending the IMSBC Code,

HAVING CONSIDERED, at its ninety-second session, amendments to the IMSBC Code, proposed and circulated in accordance with article VIII(b)(i) of the Convention,

1. ADOPTS, in accordance with article VIII(b)(iv) of the Convention, amendments to the IMSBC Code, the text of which is set out in the annex to the present resolution;
2. DETERMINES, in accordance with article VIII(b)(vi)(2)(bb) of the Convention, that the said amendments shall be deemed to have been accepted on 1 July 2014, unless, prior to that date, more than one third of the Contracting Governments to the Convention or Contracting Governments the combined merchant fleets of which constitute not less than 50 per cent of the gross tonnage of the world's merchant fleet, have notified their objections to the amendments;
3. INVITES Contracting Governments to the Convention to note that, in accordance with article VIII(b)(vii)(2) of the Convention, the amendments shall enter into force on 1 January 2015 upon their acceptance in accordance with paragraph 2 above;
4. AGREES that Contracting Governments to the Convention may apply the aforementioned amendments in whole or in part on a voluntary basis as from 1 January 2014;
5. REQUESTS the Secretary-General, in conformity with article VIII(b)(v) of the Convention, to transmit certified copies of the present resolution and the text of the amendments contained in the annex to all Contracting Governments to the Convention;
6. ALSO REQUESTS the Secretary-General to transmit copies of this resolution and its annex to Members of the Organization which are not Contracting Governments to the Convention.

\* \* \*

ANNEX

**AMENDMENTS TO THE INTERNATIONAL MARITIME  
SOLID BULK CARGOES (IMSBC) CODE**

**Section 1 – General provisions**

**1.3 Cargoes not listed in this Code**

**1.3.3 Format for the properties of cargoes not listed in this Code and conditions of the carriage**

1 At the end of the title, insert a footnote "\*" with the following:

"\* Refer to MSC.1/Circ.1453 on *Guidelines for the submission of information and completion of the format for the properties of cargoes not listed in the International Maritime Solid Bulk Cargoes (IMSBC) Code and their conditions of carriage*, according to subsection 1.3.3 of the IMSBC Code."

**1.4 Application and implementation of this Code**

2 Replace the last sentence of paragraph 1.4.2 with the following:

"The texts in the sections for "Description", "Characteristics (other than CLASS and GROUP)", "Hazard" and "Emergency procedures" of individual schedules of solid bulk cargoes in appendix 1."

**1.7 Definitions**

3 Insert the following new definitions in alphabetical order:

"*GHS* means the fourth revised edition of the Globally Harmonized System of Classification and Labelling of Chemicals, published by the United Nations as document ST/SG/AC.10/30/Rev.4."

"*Manual of Tests and Criteria* means the fifth revised edition of the United Nations publication entitled "Recommendations on the Transport of Dangerous Goods, Manual of Tests and Criteria" (ST/SG/AC.10/11/Rev.5/Amendment 1)"

"*Potential sources of ignition* means, but is not limited to, open fires, machinery exhausts, galley uptakes, electrical outlets and electrical equipment unless they are of certified safe type\*."

---

\* For cargo spaces, refer to SOLAS II-2/19.3.2."

"*Sources of heat* means heated ship structures, where the surface temperature is liable to exceed 55°C. Examples of such heated structures are steam pipes, heating coils, top or side walls of heated fuel and cargo tanks, and bulkheads of machinery spaces."

and all numerical references to definitions are deleted, keeping them in alphabetical order only.

- 4 Insert a new sentence at end of definition of *Competent authority* as follows:

"The competent authority shall operate independently from the shipper."

### **Section 3 – Safety of personnel and ship**

#### **3.6 Cargo under in-transit fumigation**

- 5 The existing text under 3.6 is renumbered as 3.6.1.

- 6 Insert new paragraphs 3.6.2 and 3.6.3 as follows:

"3.6.2 When a fumigant is used, such as phosphine gas, for fumigation-in-transit, due consideration shall be given to the severe toxicity of fumigants, taking into account that fumigants may enter into occupied spaces despite many precautions taken. In particular, in the case that fumigant leaks from a cargo hold under fumigation, the possibility should be kept in mind that it may enter the engine-room via pipe tunnels, ducts, and piping of any kind, including wiring ducts on or below deck, or dehumidifier systems that may be connected to parts of the cargo hold or compartments of the engine-room. Attention shall be given to potential problem areas such as bilge and cargo line systems and valves\*. In all cases, ventilation procedures on board the ship during the voyage, should be scrutinized with regard to the possibility of drawing in the fumigant gas such as by incorrect ventilation procedures and settings, vacuum creation due to incorrect closing devices or flap settings, air conditioning and closed loop ventilation of the accommodation. Prior to commencement of fumigation procedures, it should be verified that ventilation flaps and closing devices are set correctly and that means of closing and sealing of all the bulkhead openings (such as doors and manholes) leading from the engine-room to piping tunnels/duct keels and other spaces that in case of leaks could become unsafe to enter during the fumigation are effective, confirmed closed and have warning signs posted.

---

\* Refer to subsection 3.3.2.10 of MSC.1/Circ.1264 as amended by MSC.1/Circ.1396.

3.6.3 Gas concentration safety checks shall also be made at all appropriate locations, which shall at least include: accommodation; engine-rooms; areas designated for use in navigation of the ship; and frequently visited working areas and stores, such as the forecastle head spaces, adjacent to cargo holds being subject to fumigation in transit, shall be continued throughout the voyage at least at eight-hour intervals or more frequently if so advised by the fumigator-in-charge. Special attention shall also be paid to potential problem areas such as bilge and cargo line systems. These readings shall be recorded in the ship's logbook."

### **Section 4 – Assessment of acceptability of consignments for safe shipment**

#### **4.3 Certificates of test**

- 7 Replace the first sentence of paragraph 4.3.2 with the following:

"When a concentrate or other cargo which may liquefy is carried, the shipper shall provide the ship's master or his representative with a signed certificate of the TML, and a signed certificate or declaration of the moisture content, each issued by an entity recognized by the Competent Authority of the port of loading."

8 Insert new paragraph 4.3.3 with the accompanying footnote as follows:

"4.3.3 When a concentrate or other cargo which may liquefy is carried, procedures for sampling, testing and controlling moisture content to ensure the moisture content is less than the TML when it is on board the ship shall be established by the shipper, taking account of the provisions of this Code. Such procedures shall be approved and their implementation checked by the competent authority of the port of loading\*. The document issued by the competent authority stating that the procedures have been approved shall be provided to the master or his representative.

---

\* Refer to MSC.1/Circ1454 on *Guidelines for developing and approving procedures for sampling, testing and controlling the moisture content for solid bulk cargoes which may liquefy.*"

9 Insert new paragraph 4.3.4 as follows:

"4.3.4 If the cargo is loaded on to the ship from barges, in developing the procedures under 4.3.3 the shipper shall include procedures to protect the cargo on the barges from any precipitation and water ingress."

and renumber the existing paragraphs 4.3.3 and 4.3.4 as 4.3.5 and 4.3.6, respectively.

10 A new sentence is inserted to the end of the new paragraph 4.3.6 as follows:

"However, it is important to ensure that the samples taken are representative of the whole depth of the stockpile."

#### **4.4 Sampling procedures**

11 Insert new paragraph 4.4.3 as follows:

"4.4.3 For a concentrate or other cargo which may liquefy, the shipper shall facilitate access to stockpiles for the purpose of inspection, sampling and subsequent testing by the ship's nominated representative."

12 Renumber the existing paragraphs 4.4.3, 4.4.4, 4.4.5 and 4.4.6 as 4.4.4, 4.4.5, 4.4.6 and 4.4.7, respectively.

13 In the renumbered paragraph 4.4.6, replace the sentence "Samples shall be immediately placed in suitable sealed containers which are properly marked" with the sentence "Samples for moisture testing shall be immediately placed in suitable airtight, non-absorbent containers with a minimum of free air space to minimize any change in moisture content, such containers being properly marked".

14 Insert a new paragraph 4.4.8 as follows:

"4.4.8 For unprocessed mineral ores the sampling of stationary stockpiles shall be carried out only when access to the full depth of the stockpile is available and samples from the full depth of the stockpile can be extracted."

- 15 In subsection 4.7, the existing reference "ISO 3082:1998" is replaced with the following:  
"ISO 3082:2009 – Iron ores – Sampling and sample preparation procedures.  
(Note: Under this Standard the in situ sampling of ships and stockpiles is not permitted)."
- 16 A new reference in subsection 4.7 is inserted after "ISO 3082:2009" as follows:  
"IS1405:2010 – Iron Ores – Sampling & Sample Preparation – Manual Method.  
(Note: This Indian Standard covers the in situ sampling of stockpiles up to a height of 3 m)."

## **Section 7 – Cargoes that may liquefy**

### **7.2 Conditions for hazards**

- 17 The existing paragraph 7.2.2 is replaced with the following:  
"7.2.2 Liquefaction does not occur when the cargo consists of large particles or lumps and water passes through the spaces between the particles and there is no increase in the water pressure."

## **Section 8 – Test procedures for cargoes that may liquefy**

### **8.4 Complementary test procedure for determining the possibility of liquefaction**

- 18 The existing paragraph under subsection 8.4 is numbered as 8.4.1.
- 19 Insert a new paragraph 8.4.2 as follows:  
"8.4.2 If samples remain dry following a can test, the moisture content of the material may still exceed the Transportable Moisture Limit (TML)."

## **Section 9 – Materials possessing chemical hazards**

### **9.2 Hazard classification**

#### **9.2.3 *Materials hazardous only in bulk (MHB)***

- 20 In paragraph 9.2.3, replace the existing text under the heading with the following:

##### **"9.2.3.1 General**

9.2.3.1.1 These are materials which possess chemical hazards when transported in bulk other than materials classified as packaged dangerous goods in the IMDG Code. These materials present a significant risk when carried in bulk and require special precautions.

9.2.3.1.2 A material shall be classified as MHB if the material possesses one or more of the chemical hazards as defined below. When a test method is prescribed, representative samples of the cargo to be carried shall be used for testing. Samples shall be taken 200 to 360 mm inward from the surface at 3 m intervals over the length of a stockpile.

9.2.3.1.3 A material may also be classified as MHB by analogy with similar cargoes with known hazardous properties or by records of accidents.

### 9.2.3.2 Combustible solids

9.2.3.2.1 These are materials which are readily combustible or easily ignitable when transported in bulk and do not meet the established criteria for inclusion in class 4.1 (see 9.2.2.1 of the IMSBC Code).

9.2.3.2.2 Powdered, granular or pasty materials shall be classified as MHB when the time of burning of one or more of the test runs, performed in accordance with the preliminary screening test method described in the United Nations Manual of Tests and Criteria, part III, 33.2.1.4.3.1, is less than 2 minutes. Powders of metals or metal alloys shall be classified as MHB when they can be ignited and the reaction spreads over the whole length of the sample in 20 minutes or less. The test sample in the preliminary screening test is 200 mm in length. A summary of this approach is presented in the table below:

<b>Solid Cargo</b>	<b>Hazard Class 4.1, PG III Burn time, Burn distance</b>	<b>MHB Burn time, Burn distance</b>
Powdered Metal	more than 5 minutes but not more than 10 minutes, 250 mm	≤20 minutes, 200 mm
Solid Material	<45 seconds, 100 mm	≤2 minutes, 200 mm

### 9.2.3.3 Self-heating solids

9.2.3.3.1 These are materials that self-heat when transported in bulk and do not meet the established criteria for inclusion in class 4.2 (see 9.2.2.2).

9.2.3.3.2 A material shall be classified as MHB if, in the tests performed in accordance with the test method given in the United Nations Manual of Tests and Criteria, part III, 33.3.1.6, the temperature of the test sample rises by more than 10°C when using a 100 mm cube sample at 140°C and at 100°C. The flow chart below illustrates the test procedure.



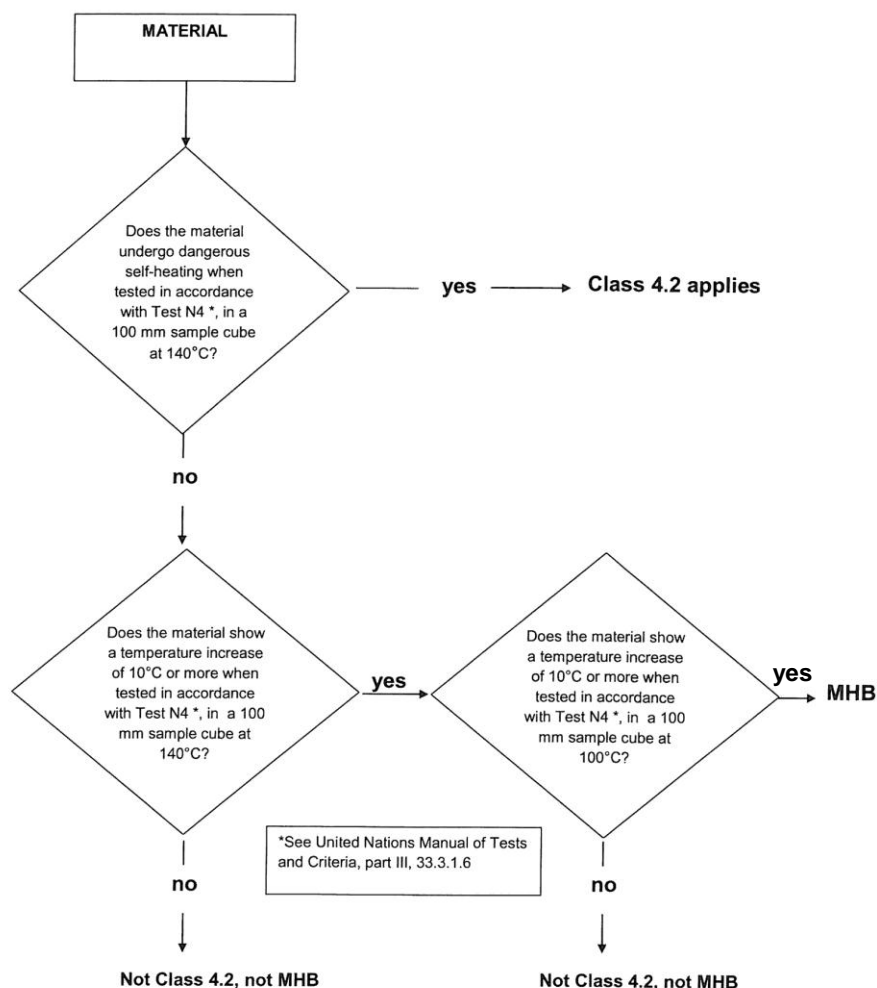

9.2.3.3.3 In addition, a material shall be classified as MHB if a temperature rise of 10°C or more over ambient temperature is observed during any portion of the test performed in accordance with the test method described in United Nations Manual of Tests and Criteria, part III, 33.4.1.4.3.5. When performing this test, the temperature of the sample should be measured continuously over 48 hours. If, at the end of the 48-hour period the temperature is increasing, the test period shall be extended in accordance with the test method.

#### 9.2.3.4 Solids that evolve into flammable gas when wet

9.2.3.4.1 These are materials that emit flammable gases when in contact with water when transported in bulk and do not meet established criteria for inclusion in class 4.3 (see 9.2.2.3).

9.2.3.4.2 A material shall be classified as MHB if, in tests performed in accordance with the test method given in the United Nations Manual of Tests and Criteria, part III, 33.4.1, the flammable gas evolution rate is greater than zero. When performing this test, the rate of evolution of gas shall be calculated over 48 hours at one-hour intervals. If at the end of the 48-hour period the rate of evolution is increasing, the test period shall be extended in accordance with the test method.

### **9.2.3.5 Solids that evolve toxic gas when wet**

9.2.3.5.1 These are materials that emit toxic gases when in contact with water when transported in bulk.

9.2.3.5.2 A material shall be classified as MHB if, in tests performed in accordance with the test method given in the United Nations Manual of Tests and Criteria, part III, 33.4.1, the toxic gas evolution rate is greater than zero. Toxic gas evolution shall be measured using the same test procedure for flammable gas evolution as prescribed in the test method. When performing this test, the rate of evolution of gas shall be calculated over 48 hours at 1-hour intervals. If at the end of the 48-hour period the rate of evolution is increasing, the test period shall be extended in accordance with the test method.

9.2.3.5.3 The gas shall be collected over the test period prescribed above. The gas shall be chemically analysed and tested for toxicity if the gas is unknown and no acute inhalation toxicity data is available. If the gas is known, inhalation toxicity shall be assessed based on all information available, using testing as a last resort option for concluding this hazard. Toxic gases in this respect are gases showing acute inhalation toxicity (LC<sub>50</sub>) of or below 20,000 ppmV or 20 mg/l by 4 hours' testing (GHS Acute Toxicity Gases/Vapours Category 4).

### **9.2.3.6 Toxic solids**

9.2.3.6.1 These are materials that have toxic hazards to humans if inhaled or with contact with skin when loaded, unloaded, or transported in bulk and do not meet the established criteria for inclusion in class 6.1 (see 9.2.2.5).

9.2.3.6.2 A material shall be classified as MHB in accordance with the criteria laid down within part 3 of the GHS:

- .1 cargoes developing cargo dust with an acute inhalation toxicity (LC<sub>50</sub>) of 1-5 mg/l by 4 hours testing (GHS Acute Toxicity Dusts Category 4);
- .2 cargoes developing cargo dust exhibiting an inhalation toxicity of equal to or less than 1 mg/litre/4h (GHS Specific Target Organ Toxicity Single Exposure Inhalation Dust Category 1) or below 0.02 mg/litre/6h/d (GHS Specific Target Organ Toxicity Repeated Dose Inhalation Dust Category 1);
- .3 cargoes exhibiting an acute dermal toxicity (LD<sub>50</sub>) of 1,000-2,000 mg/kg (GHS Acute Toxicity Dermal Category 4);
- .4 cargoes exhibiting a dermal toxicity of or below 1000 mg (GHS Specific Target Organ Toxicity Single Exposure Dermal Category 1) or below 20 mg/kg bw/d by 90 days testing (GHS Specific Target Organ Toxicity Repeated Dose Dermal Category 1);
- .5 cargoes exhibiting carcinogenicity (GHS Category 1A and 1B), mutagenicity (GHS Category 1A and 1B) or reprotoxicity (GHS Category 1A and 1B).

### 9.2.3.7 Corrosive solids

9.2.3.7.1 These are materials that are corrosive to skin, eye or to metal or are respiratory sensitizers and do not meet the established criteria for inclusion in class 8 (see 9.2.2.7).

9.2.3.7.2 A material shall be classified as MHB in accordance with the criteria laid down within part 3 of the GHS:

- .1 cargoes which are known to be a respiratory sensitizer (GHS Respiratory Sensitization Category 1);
- .2 cargoes exhibiting skin irritation with a mean value of or higher than 2.3 for erythema/eschar or oedema (GHS Skin Corrosion/Irritation Category 2);
- .3 cargoes exhibiting eye irritation with a mean value of or higher than 1 for corneal opacity/irititis or 2 for conjunctival redness/oedema (GHS Serious Eye Damage Category 1 or Eye Irritation Category 2A).

9.2.3.7.3 A material shall be classified as MHB when the corrosion rate on either steel or aluminium surfaces is between 4 mm and 6.25 mm a year at a test temperature of 55°C when tested on both materials. For the purposes of testing steel, type S235JR+CR (1.0037 resp. St 37-2), S275J2G3+CR (1.0144 resp. St 44-3), ISO 3574:199, Unified Numbering Systems (UNS) G10200 or SAE 1020, and for testing aluminium, non-clad, types 7075-T6 or AZ5GU T6 shall be used. An acceptable test is prescribed in the United Nations Manual of Tests and Criteria, part III, section 37. When this test is performed the sample shall contain at least 10% moisture by mass. If the representative sample of the cargo to be shipped does not contain more than 10% moisture by mass, water shall be added to the sample."

## Appendix 1 – Individual schedules of solid bulk cargoes

### AMMONIUM NITRATE UN 1942

**with not more than 0.2% total combustible material, including any organic substance, calculated as carbon to the exclusion of any other added substance**

21 In the section for Stowage and Segregation replace the sentence "There shall be no sources of heat or ignition in the cargo space." with the sentence "Separated from" sources of heat or ignition (see also **Loading**)."

22 In the section for Loading, insert as the first sentence the following:

"This cargo shall not be loaded in cargo spaces adjacent to fuel oil tank(s), unless heating arrangements for the tank(s) are disconnected and remain disconnected during the entire voyage."

### **AMMONIUM NITRATE-BASED FERTILIZER UN 2067**

23 The following text contained in the section for Description, is moved under the Bulk Cargo Shipping Name:

"Ammonium nitrate-based fertilizers classified as UN 2067 are uniform mixtures containing ammonium nitrate as the main ingredient within the following composition limits:

- .1 not less than 90% ammonium nitrate with not more than 0.2% total combustible/organic material calculated as carbon and with added matter, if any, which is inorganic and inert towards ammonium nitrate; or
- .2 less than 90% but more than 70% ammonium nitrate with other inorganic materials or more than 80% but less than 90% ammonium nitrate mixed with calcium carbonate and/or dolomite and/or mineral calcium sulphate and not more than 0.4% total combustible/organic material calculated as carbon; or
- .3 ammonium nitrate-based fertilizers containing mixtures of ammonium nitrate and ammonium sulphate with more than 45% but less than 70% ammonium nitrate and not more than 0.4% total combustible organic material calculated as carbon such that the sum of the percentage compositions of ammonium nitrate and ammonium sulphate exceeds 70%."

24 In the section for Stowage and Segregation, the text "Not to be stowed immediately adjacent to any tank, double bottom or pipe containing fuel oil heated to more than 50°C" is replaced with the following:

"Not to be stowed immediately adjacent to any tank, double bottom or pipe containing heated fuel oil unless there are means to monitor and control the temperature so that it does not exceed 50°C."

### **AMMONIUM NITRATE-BASED FERTILIZER UN 2071**

25 The following text contained in the section for Description, is moved under the Bulk Cargo Shipping Name:

"Ammonium nitrate-based fertilizers classified as UN 2071 are uniform ammonium nitrate based fertilizer mixtures of the nitrogen, phosphate or potash, containing not more than 70% ammonium nitrate and not more than 0.4% total combustible organic material calculated as carbon or with not more than 45% ammonium nitrate and unrestricted combustible material. Fertilizers within these composition limits are not subject to the provisions of this schedule when shown by a trough test\* that they are not liable to self-sustaining decomposition.

---

\* See UN Manual of Tests and Criteria, part III, subsection 38.2."

26 In the section for Stowage and Segregation, the text "Not to be stowed immediately adjacent to any tank or double bottom containing fuel oil heated to more than 50°C" is replaced with the following:

"Not to be stowed immediately adjacent to any tank, double bottom or pipe containing heated fuel oil unless there are means to monitor and control the temperature so that it does not exceed 50°C."

#### **AMMONIUM NITRATE-BASED FERTILIZER (non-hazardous)**

27 The following text contained in the section for Description, is moved under the Bulk Cargo Shipping Name:

"Ammonium nitrate based fertilizers transported in conditions mentioned in this schedule are uniform mixtures containing ammonium nitrate as the main ingredient within the following composition limits:

- .1 not more than 70% ammonium nitrate with other inorganic materials;
- .2 not more than 80% ammonium nitrate mixed with calcium carbonate and/or dolomite and/or mineral calcium sulphate and not more than 0.4% total combustible organic material calculated as carbon;
- .3 nitrogen type ammonium nitrate based fertilizers containing mixtures of ammonium nitrate and ammonium sulphate with not more than 45% ammonium nitrate and not more than 0.4% total combustible organic material calculated as carbon; and
- .4 uniform ammonium nitrate based fertilizer mixtures of nitrogen, phosphate or potash, containing not more than 70 % ammonium nitrate and not more than 0.4% total combustible organic material calculated as carbon or with not more than 45% ammonium nitrate and unrestricted combustible material. Fertilizers within these composition limits are not subject to the provisions of this schedule when shown by a trough test that they are liable to self-sustaining decomposition or if they contain an excess of nitrate greater than 10% by mass."

and its corresponding footnote is amended as follows:

---

\* See UN Manual of Tests and Criteria, part III, subsection 38.2."

28 In the section Stowage and Segregation the text "Not to be stowed immediately adjacent to any tank, double bottom or pipe containing fuel oil heated to more than 50°C" is replaced with the following:

"Not to be stowed immediately adjacent to any tank, double bottom or pipe containing heated fuel oil unless there are means to monitor and control the temperature so that it does not exceed 50°C."

### **CALCIUM NITRATE UN 1454**

29 The following text contained in the section for Description, is moved under the Bulk Cargo Shipping Name:

"The provisions of this Code shall not apply to the commercial grades of calcium nitrate fertilizers consisting mainly of a double salt (calcium nitrate and ammonium nitrate) and containing not more than 10% ammonium nitrate and at least 12% water of crystallization."

### **CALCIUM NITRATE FERTILIZER**

30 The following text is inserted under the Bulk Cargo Shipping Name:

"The provisions of this schedule shall apply only for cargoes containing not more than 15.5% total nitrogen and at least 12% water."

31 The following text is deleted from the section for Description:

"and containing not more than 15.5% total nitrogen and at least 12% water".

### **CHARCOAL**

32 The following text contained in the section for Hazard, is moved at the end in the section for Loading:

"Hot charcoal screenings in excess of 55°C shall not be loaded."

### **FERROUS METAL BORINGS, SHAVINGS, TURNINGS or CUTTINGS UN 2793**

33 The following text contained in the section for Description is moved under the Bulk Cargo Shipping Name:

"This schedule shall not apply to consignments of materials which are accompanied by a declaration submitted prior to loading by the shipper and stating that they have no self-heating properties when transported in bulk."

### **METAL SULPHIDE CONCENTRATES**

34 The following text contained in the section for Hazard, is moved at the end in the section for Precautions:

"When a Metal Sulphide Concentrate is considered as presenting a low fire-risk, the carriage of such cargo on a ship not fitted with a fixed gas fire extinguishing system shall be subject to the Administration's authorization as provided by SOLAS regulation II-2/10.7.1.4."

### **PEAT MOSS**

35 The following text contained in the section for Hazard, is moved at the end in the section for Loading:

"Peat Moss having a moisture content of more than 80% by weight shall only be carried on specially fitted or constructed ships (see paragraph 7.3.2 of this Code)."

## SAND

36 The following text is inserted under the Bulk Cargo Shipping Name:

"Sands included in this schedule are:

Foundry sand	Silica sand
Potassium felspar sand	Soda felspar sand"
Quartz sand	

37 The following text in the section for Description is deleted:

"Sands included in this schedule are:

FOUNDRY SAND	SILICA SAND
POTASSIUM FELSPAR SAND	SODA FELSPAR SAND"
QUARTZ SAND	

## SEED CAKE

**containing vegetable oil UN 1386(b) solvent extractions and expelled seeds, containing not more than 10% of oil and when the amount of moisture is higher than 10%, not more than 20% of oil and moisture combined.**

38 The following text is inserted under the Bulk Cargo Shipping Name:

"The provisions of this schedule shall not apply to:

- .1 solvent extracted rape seed meal, soya bean meal, cotton seed meal and sunflower seed meal, containing not more than 4% oil and 15% oil and moisture combined and being substantially free from flammable solvents;
- .2 mechanically expelled citrus pulp pellets containing not more than 2.5% oil and 14% oil and moisture combined;
- .3 mechanically expelled corn gluten meal containing not more than 11.0% oil and 23.6% oil and moisture combined;
- .4 mechanically expelled corn gluten feed pellets containing not more than 5.2% oil and 17.8% oil and moisture combined; and
- .5 mechanically expelled beet pulp pellets containing not more than 2.8% oil and 15.0% oil and moisture combined.

A certificate from a person recognized by the competent authority of the country of shipment shall be provided by the shipper, prior to loading, stating that the provisions of the exemption are met."

39 In the section for Description, the following paragraph is deleted:

"The provisions of this schedule should not apply to solvent extracted rape seed meal, pellets, soya bean meal, cotton seed meal and sunflower seed meal, containing not more than 4% oil and 15% oil and moisture combined and being substantially free from flammable solvents. The provisions of this schedule also apply to mechanically expelled citrus pulp pellets containing not more than 2.5% oil and 14% oil and moisture combined. A certificate from a person recognized by the competent authority of the country of shipment should be provided by the shipper, prior to loading, stating that the provisions of the exemption are met."

### **SEED CAKE (non-hazardous)**

40 The following text is inserted under the Bulk Cargo Shipping Name:

"The provisions of this schedule shall only apply to:

- .1 solvent extracted rape seed meal, soya bean meal, cotton seed meal and sunflower seed meal, containing not more than 4% oil and 15% oil and moisture combined and being substantially free from flammable solvents;
- .2 mechanically expelled citrus pulp pellets containing not more than 2.5% oil and 14% oil and moisture combined;
- .3 mechanically expelled corn gluten meal containing not more than 11.0% oil and 23.6% oil and moisture combined;
- .4 mechanically expelled corn gluten feed pellets containing not more than 5.2% oil and 17.8% oil and moisture combined; and
- .5 mechanically expelled beet pulp pellets containing not more than 2.8% oil and 15.0% oil and moisture combined."

41 In the section for Description, the following text is deleted:

"The provisions of this schedule apply to solvent extracted rape seed meal, pellets, soya bean meal, cotton seed meal and sunflower seed meal, containing not more than 4% oil and 15% oil and moisture combined and being substantially free from flammable solvents. The provisions of this schedule also apply to mechanically expelled citrus pulp pellets containing not more than 2.5% oil and 14% oil and moisture combined."

and the following text contained in the section for Description, is moved at the end of the section for Loading:

"A certificate from a person recognized by the competent authority of the country of shipment shall be provided by the shipper, prior to loading, stating that the requirements for exemption as set out either in the schedule for seed cake UN 1386 (b) or UN 2217, whichever is applicable, are met."



**SILICOMANGANESE (low carbon)**

**with known hazard profile or known to evolve gases with silicon content of 25% or more**

42 In the Bulk Cargo Shipping Name, delete the words "**with known hazard profile or known to evolve gases with silicon content of 25% or more**".

43 Replace the existing text under the section for Description, with the following:

"A ferroalloy comprising principally manganese and silicon, mainly used as a deoxidizer and alloying element in the steel-making process. Particle or lump of blackish brown, silver white metal."

44 The existing table of Characteristics is replaced with the following:

<b>Angle of repose</b>	<b>Bulk density (kg/m<sup>3</sup>)</b>	<b>Stowage factor (m<sup>3</sup>/t)</b>
Not applicable	3,000 to 3,300	0.30 to 0.33
<b>Size</b>	<b>Class</b>	<b>Group</b>
10 mm to 150 mm	MHB	B

45 Replace the existing text under the section for Hazard, with the following:

"This cargo is non-combustible and has a low fire-risk. However, in contact with water this cargo may evolve hydrogen, a flammable gas that may form explosive mixtures with air and may, under similar conditions, produce phosphine and arsine, which are highly-toxic gases. This cargo is liable to reduce oxygen content in a cargo space. May cause long-term health effect."

46 In the section for Precautions, the following text is deleted:

"Prohibition of smoking in dangerous areas shall be enforced, and clearly legible "NO SMOKING" signs shall be displayed. Electrical fittings and cables shall be in good condition and properly safeguarded against short circuits and sparking. Where a bulkhead is required to be suitable for segregation purposes, cable and conduit penetrations of the decks and bulkheads shall be sealed against the passage of gas and vapour. Ventilation systems shall be shut down or screened and air condition systems, if any, placed on recirculation during loading or discharge, in order to minimize the entry of dust into living quarters or other interior spaces of the ship. Precautions shall be taken to minimize the extent to which dust may come in contact with moving parts of deck machinery and external navigation aids (e.g. navigation lights)."

**SULPHUR (formed, solid)**

47 The following text contained in the section for Description, is moved under the Bulk Cargo Shipping Name:

"This schedule shall not apply to crushed, lump and coarse-grained sulphur (see SULPHUR UN 1350), or to co-products from sour gas processing or oil refinery operations NOT subjected to the above-described forming process."

48 Insert the following new individual schedules accordingly in alphabetical order:

**"ALUMINA HYDRATE**

**Description**

Alumina hydrate is a fine, moist, white (light coloured), odourless powder. Insoluble in water and organic liquids.

**Characteristics**

<b>Angle of repose</b>	<b>Bulk density (kg/m<sup>3</sup>)</b>	<b>Stowage factor (m<sup>3</sup>/t)</b>
Not applicable	500 to 1,500	0.67 to 2.0
<b>Size</b>	<b>Class</b>	<b>Group</b>
Fine powder	MHB	A and B

**Hazard**

This cargo may liquefy if shipped at moisture content in excess of its Transportable Moisture Limit (TML). See sections 7 and 8 of the Code. Alumina Hydrate dust is very abrasive and penetrating. Irritating to eyes, skin and mucous membranes. This cargo is non-combustible or has low fire-risks.

**Stowage and segregation**

Separated from oxidizing materials.

**Hold cleanliness**

Clean and dry as relevant to the hazards of the cargo.

**Weather precautions**

When a cargo is carried in a ship other than a specially constructed or fitted cargo ship complying with the requirements in subsection 7.3.2 of this Code, the following provisions shall be complied with:

- .1 the moisture content of the cargo shall be kept less than its TML during loading operations and the voyage;
- .2 unless expressly provided otherwise in this individual schedule, the cargo shall not be handled during precipitation;
- .3 unless expressly provided otherwise in this individual schedule, during handling of the cargo, all non-working hatches of the cargo spaces into which the cargo is loaded or to be loaded shall be closed;
- .4 the cargo may be handled during precipitation under the conditions stated in the procedures required in subsection 4.3.3 of this Code; and
- .5 the cargo in a cargo space may be discharged during precipitation provided that the total amount of the cargo in the cargo space is to be discharged in the port.

### **Loading**

Trim in accordance with the relevant provisions required under sections 4 and 5 of the Code.

### **Precautions**

Bilge wells shall be clean, dry and covered as appropriate, to prevent ingress of the cargo. Bilge system of a cargo space to which this cargo is to be loaded shall be tested to ensure it is working. Appropriate precautions shall be taken to protect machinery and accommodation spaces from the dust of the cargo. Due consideration shall be paid to protect equipment from the dust of the cargo. Persons who may be exposed to the dust of the cargo shall wear goggles or other equivalent dust eye-protection and dust filter masks. Those persons shall wear protective clothing, as necessary.

### **Ventilation**

No special requirements.

### **Carriage**

The appearance of the surface of this cargo shall be checked regularly during voyage. If free water above the cargo or fluid state of the cargo is observed during voyage, the master shall take appropriate actions to prevent cargo shifting and potential capsizing of the ship, and give consideration to seeking emergency entry into a place of refuge.

### **Discharge**

No special requirements.

### **Clean-up**

The water used for the cleaning of the cargo spaces, after discharge of this cargo, shall not be pumped by the fixed bilge pumps. A portable pump shall be used, as necessary, to clear the cargo spaces of the water.

### **Emergency procedures**

<p style="text-align: center;"><b>Special emergency equipment to be carried</b> Protective clothing (gloves, boots, coveralls, headgear). Self-contained breathing apparatus.</p>
<p style="text-align: center;"><b>Emergency procedures</b> Wear protective clothing and self-contained breathing apparatus</p> <p style="text-align: center;"><b>Emergency action in the event of fire</b> Nil (non-combustible)</p> <p style="text-align: center;"><b>Medical First Aid</b> Refer to the Medical First Aid Guide (MFAG), as amended.</p>

11

## "ALUMINIUM SMELTING / REMELTING BY-PRODUCTS, PROCESSED"

*The provisions of this schedule shall not apply to ALUMINIUM SMELTING BY-PRODUCTS or ALUMINIUM REMELTING BY-PRODUCTS UN 3170.*

### Description

Product obtained by treating the by-products of merging/recasting of aluminium with water and/or alkalis solutions to render the material less reactive with water. A damp powder with a slight smell of ammonia.

### Characteristics

Angle of repose	Bulk density (kg/ m <sup>3</sup> )	Stowage factor (m <sup>3</sup> /t)
Not applicable	1,080 to 1,750	0.57 to 0.93
Size	Class	Group
Less than 1 mm	MHB	A and B

### Hazard

This cargo may develop small amount of hydrogen, a flammable gas which may form explosive mixtures with air, and of ammonia, which is a highly toxic gas.

This cargo may liquefy if shipped at moisture content in excess of its transportable moisture limit (TML). See sections 7 and 8 of the Code. Corrosive to eyes.

### Stowage and segregation

"Separated from" foodstuffs and all Class 8 liquids. Segregation as for Class 4.3 materials.

### Hold cleanliness

Clean and dry as relevant to the hazards of the cargo.

### Weather precautions

This cargo shall be kept as dry as practicable and the moisture content shall be kept less than its TML during loading operations and the voyage. This cargo shall not be handled during precipitation. During handling of this cargo, all non-working hatches of the cargo spaces into which this cargo is loaded or to be loaded shall be closed.

### Loading

Trim in accordance with the relevant provisions of sections 4 and 5 of this Code.

### Precautions

Persons who may be exposed to the cargo shall wear personal protective equipment, including goggles and/or skin protection as necessary. Prior to loading this cargo, a weathering certificate shall be provided by the manufacturer or shipper stating that, after manufacture, the material was stored under cover, but exposed to the weather in the particle size to be shipped, for not less than four weeks prior to shipment. Whilst the ship is alongside and the hatches of the cargo spaces containing this cargo are closed, the mechanical ventilation shall be operated continuously as weather permits. During handling of this cargo, "NO SMOKING" signs shall be posted on decks and in areas adjacent to cargo spaces and no naked lights shall be permitted in these areas. Bulkheads between the cargo spaces and the engine-room shall be gastight. Inadvertent pumping through machinery spaces shall be avoided. Bilge wells shall be clean, dry and covered as appropriate, to prevent ingress of the cargo.

**Ventilation**

Continuous mechanical ventilation shall be conducted during the voyage for the cargo spaces carrying this cargo. If maintaining ventilation endangers the ship or the cargo, it may be interrupted unless there is a risk of explosion or other danger due to interruption of the ventilation. In any case, mechanical ventilation shall be maintained for a reasonable period prior to discharge. Ventilation shall be arranged such that any escaping gases are minimized from reaching living quarters on or under the deck.

**Carriage**

For quantitative measurements of hydrogen, ammonia and acetylene, suitable detectors for each gas or combination of gases shall be on board while this cargo is carried. The detectors shall be of certified safe type for use in explosive atmosphere. The concentrations of these gases in the cargo spaces carrying this cargo shall be measured regularly, during voyage, and the results of the measurements shall be recorded and kept on board. The appearance of the surface of this cargo shall be checked regularly during voyage. If free water above the cargo or fluid state of the cargo is observed during voyage, the master shall take appropriate actions to prevent cargo shifting and potential capsize of the ship, and give consideration to seeking emergency entry into a place of refuge. Hatches of the cargo spaces carrying this cargo shall be weathertight to prevent the ingress of water.

**Discharge**

No special requirements.

**Clean-up**

Persons who may be exposed to the cargo shall wear personal protective equipment including goggles and/or skin protection as necessary. After discharge of this cargo, the bilge wells and scuppers of the cargo spaces shall be checked and any blockage shall be removed.

Prior to using water for hold cleaning, holds should be swept to remove as much cargo residues as practicable.

**Emergency procedures**

<p><b>Special emergency equipment to be carried</b></p> <p>Nil</p>
<p><b>Emergency procedures</b></p> <p>Nil</p>
<p><b>Emergency action in the event of fire</b></p> <p>Batten down and use CO<sub>2</sub> if fitted</p>
<p><b>Medical first aid</b></p> <p>Refer to the Medical First Aid Guide (MFAG), as amended</p>

## "CLINKER ASH, WET

### Description

Coal ash discharged from coal-fired power stations. Grey-coloured, possibly ranging from near-white to near-black, and odourless substance collected from the bottom of boilers, and resembles sand. Moisture content is about 15% to 23%. Insoluble in water.

### Characteristics

Angle of repose	Bulk density (kg/m <sup>3</sup> )	Stowage factor (m <sup>3</sup> /t)
Not applicable	600 to 1,700	0.6 to 1.7
Size	Class	Group
Up to 90 mm	MHB	A and B

### Hazard

The material may liquefy if shipped at a moisture content in excess of its Transportable Moisture Limit (TML). See sections 7 and 8 of the Code. May cause long-term health effects. This cargo is non-combustible or has a low fire-risk.

### Stowage and Segregation

No special requirements.

### Hold cleanliness

No special requirements.

### Weather precautions

This cargo shall be kept as dry as practicable before loading, during loading and while on the voyage. When a cargo is carried in a ship other than a specially constructed or fitted cargo ship complying with the requirements in subsection 7.3.2 of this Code, the following provisions shall be complied with:

- .1 the moisture content of the cargo shall be kept less than its TML during loading operations and the voyage;
- .2 unless expressly provided otherwise in this individual schedule, the cargo shall not be handled during precipitation;
- .3 unless expressly provided otherwise in this individual schedule, during handling of the cargo, all non-working hatches of the cargo spaces into which the cargo is loaded or to be loaded shall be closed;
- .4 the cargo may be handled during precipitation under the conditions stated in the procedures required in subsection 4.3.3 of this Code; and
- .5 the cargo in a cargo space may be discharged during precipitation provided that the total amount of the cargo in the cargo space is to be discharged in the port.

**Loading**

Trim in accordance with the relevant provisions required under sections 4 and 5 of the Code.

**Precautions**

Persons who may be exposed to the dust of the cargo shall wear gloves, goggles or other equivalent dust eye-protection and dust filter masks.

**Ventilation**

No special requirements.

**Carriage**

No special requirements.

**Discharge**

No special requirements.

**Clean-Up**

No special requirements.

**Emergency procedures**

<p style="text-align: center;"><b>Special emergency equipment to be carried</b> Protective clothing (goggles, dust filter masks, gloves, coveralls).</p>
<p style="text-align: center;"><b>Emergency procedures</b> Wear protective clothing.</p> <p style="text-align: center;"><b>Emergency action in the event of fire</b> Nil (non-combustible)</p> <p style="text-align: center;"><b>Medical First Aid</b> Refer to the Medical First Aid Guide (MFAG), as amended.</p>

**"COAL TAR PITCH****Description**

A coarse distilled residue of Coal Tar, a by-product of Cokes production. Mostly comprises many kinds of polycyclic aromatic hydrocarbon. A black solid at ambient temperature. It is insoluble in water. A raw material in use for electrodes and materials covering pitch bound on metallurgy coke. The moisture content is up to 6%.

### Characteristics

Angle of repose	Bulk density (kg/m <sup>3</sup> )	Stowage factor (m <sup>3</sup> /t)
Not applicable	600 to 1,100	0.9 to 1.7
Size	Class	Group
Up to 100mm 0 to 10% of fine particles: less than 1 mm	MHB	B

### Hazard

This cargo is non-combustible or has a low fire-risk. When heated, it melts and turns into inflammable liquid. It softens between 70°C and 120°C. Corrosive to eyes. May cause long-term health effects.

### Stowage and segregation

No special requirements.

### Hold cleanliness

No special requirements.

### Weather precautions

No special requirements.

### Loading

Trim in accordance with the relevant provisions required under sections 4 and 5 of the Code.

### Precautions

Persons who may be in contact with this cargo shall be supplied with protective gloves, dust masks, protective clothing and goggles.

### Ventilation

No special requirements.

### Carriage

No special requirements.

### Discharge

No special requirements.

### Clean-up

No special requirements.



## Emergency procedures

<p><b><u>Special emergency equipment to be carried</u></b></p> <p>Protective clothing (gloves, boots, overalls, headgear, dust masks and goggles).</p>
<p><b><u>Emergency procedures</u></b></p> <p>Wear protective clothing, protective gloves, dust masks and goggles.</p> <p><b><u>Emergency action in the event of fire</u></b></p> <p>Batten down: use ship's fixed fire-fighting installation if fitted. Exclusion of air may be sufficient to control fire.</p> <p><b><u>Medical first aid</u></b></p> <p>Refer to the Medical First Aid Guide (MFAG), as amended.</p>

## "COARSE IRON AND STEEL SLAG AND ITS MIXTURE

### Description

A coarse slag arising from iron and steel manufacture, and a coarse slag mixed with one of the following substances or a combination thereof: concrete debris, fly-ash, firebricks, dust collected from iron/steel-making processes, refractory material debris and fine raw materials of iron making.

This cargo includes shaped blocks made of iron and steel slag with one of the additives or a combination of additives: cement, ground granulated blast furnace slag and fly-ash, and its debris, and their mixture with iron and steel slag.

The colour is in the range from greyish-white to dark grey, and the appearance is in the range from granulated, pebble to block shaped.

### Characteristics

Angle of repose	Bulk density (kg/m <sup>3</sup> )	Stowage factor (m <sup>3</sup> /t)
Not applicable	1,200 to 3,000	0.33 to 0.83
Size	Class	Group
90 to 100% of lumps: up to 300 mm 0 to 10% fine particles: less than 1 mm	Not applicable	C

**Hazard**

No special requirements.  
This cargo is non-combustible or has a low fire-risk.

**Stowage and segregation**

No special requirements.

**Hold cleanliness**

No special requirements.

**Weather precautions**

No special requirements.

**Loading**

Trim in accordance with the relevant provisions required under sections 4 and 5 of the Code.

When the stowage factor of this cargo is equal or less than 0.56 m<sup>3</sup>/t, the tank top may be overstressed unless the cargo is evenly spread across the tank top to equalize the weight distribution. Due consideration shall be given to ensure that the tank top is not overstressed during the voyage and during loading by a pile of the cargo.

**Precautions**

Persons who may be exposed to the dust of the cargo shall wear goggles or other equivalent dust eye-protection and dust filter masks, as necessary.

**Ventilation**

No special requirements.

**Carriage**

No special requirements.

**Discharge**

No special requirements.

**Clean-up**

No special requirements."

**"CRUSHED CARBON ANODES****Description**

Crushed Carbon Anodes are spent carbon anodes that are crushed into smaller pieces to permit their shipment for recycling. Carbon anodes are used to introduce electricity into the aluminium smelter pots. This cargo is mainly composed of black crushed lumps and pieces principally containing carbon and other impurities. The material is odourless.

<b>Angle of repose</b>	<b>Bulk density (kg/m<sup>3</sup>)</b>	<b>Stowage factor (m<sup>3</sup>/t)</b>
Not applicable	800 to 1,000	1.00 to 1.25
<b>Size</b>	<b>Class</b>	<b>Group</b>
Mainly coarse pieces up to 60 cm +	Not applicable	C

**Hazard**

This cargo may generate dust. This cargo is non-combustible or has a low fire-risk.

**Stowage and segregation**

No special requirements.

**Hold cleanliness**

No special requirements.

**Weather precautions**

No special requirements.

**Loading**

Trim in accordance with the relevant provisions required under sections 4 and 5 of the Code.

**Precautions**

Persons who may be exposed to the dust of the cargo shall wear protective clothing, goggles or other equivalent dust eye-protection, dust filter mask and barrier creams as necessary.

**Ventilation**

No special requirements.

**Carriage**

No special requirements.

**Discharge**

No special requirements.

**Clean-up**

No special requirements."

**"GRAIN SCREENING PELLETS**

*The provision of this schedule shall apply only to Grain Screening Pellets material containing not more than 6.2% oil content and not more than 17.5% oil and moisture content combined.*

**Description**

Grain Screening Pellets are animal feed products, pelletized animal feed derived from dockage removed from grains. Screenings means dockage that has been removed from grain that does not qualify for any other grain grades. Depending

upon their quality, screenings vary in level of parent and volunteer grain material, broken or shrunken kernels, hulls, weed seeds, chaff, dust and other plant material. The colour ranges from brown to yellow.

### Characteristics

Angle of repose	Bulk density (kg/m <sup>3</sup> )	Stowage factor (m <sup>3</sup> /t)
less than 30°	478 to 719	1.39 to 2.09
Size	Class	Group
Length: 12 to 38 mm Diameter: 4 to 7 mm	Not applicable	C

### Hazard

This cargo flows freely like grain. This cargo is non-combustible or has a low fire-risk.

### Stowage and segregation

No special requirements.

### Hold cleanliness

No special requirements.

### Weather precautions

This cargo shall be kept as dry as practicable. This cargo shall not be handled during precipitation. During handling of this cargo, all non-working hatches of the cargo spaces into which the cargo is loaded or to be loaded shall be closed.

### Loading

Trim in accordance with the relevant provisions required under sections 4, 5 and 6 of the Code in accordance with the shipper's declaration of the angle of repose.

A certificate from a person recognized by the competent authority of the country of shipment shall be provided by the shipper to the master, prior to loading, confirming that the oil and the moisture contents as described in the schedule have been met.

### Precautions

Persons who may be exposed to the dust of the cargo shall wear a dust filter mask, protective eyewear, and protective clothing as necessary.

### Carriage

Hatches of the cargo spaces shall be weather tight to prevent water ingress.

### Discharge

No special requirements.

### Ventilation

No special requirements.

**Clean-up**

No special requirements.

**Emergency Procedures**

No special requirements."

**"GRANULATED NICKEL MATTE (LESS THAN 2% MOISTURE CONTENT)**

**Description**

Crude dark grey nickel product composed of about 55% nickel, 20% copper and 25% other mineral impurities. The material is odourless.

**Characteristics**

Angle of repose	Bulk density (kg/m <sup>3</sup> )	Stowage factor (m <sup>3</sup> /t)
Not applicable	2,800 to 4,000	0.25 to 0.36
Size	Class	Group
Up to 3 mm	MHB	B

**Hazard**

Contact with the skin may give rise to irritation.  
This cargo is non-combustible or has a low fire-risk.  
This cargo is moderately toxic by inhalation.

**Stowage and segregation**

Separated from foodstuffs.

**Hold cleanliness**

No special requirements.

**Weather precautions**

No special requirements.

**Loading**

Trim in accordance with the relevant provisions required under sections 4 and 5 of the Code. As the density of the cargo is extremely high, the tank top may be overstressed unless the cargo is evenly spread across the tank top to equalize the weight distribution. Due consideration shall be paid to ensure that the tank top is not overstressed during voyage and during loading process by a pile of the cargo.

**Precautions**

Persons who may be exposed to the dust component of the cargo shall wear personal protective equipment including goggles or other equivalent dust eye-protection, respiratory protection, and/or skin protection as necessary. Due consideration shall be paid to prevent dust entering living quarters and enclosed working area. Eating and drinking is prohibited in the cargo work areas. Appropriate precautions shall be taken to protect machinery and accommodation spaces from the dust of the cargo.

**Carriage**

No special requirements.

**Discharge**

No special requirements.

**Ventilation**

No special requirements.

**Clean-up**

No special requirements.

**Emergency procedures**

<p><b>Special emergency equipment to be carried</b> Protective clothing ( gloves, boots, coveralls ) Self-contained breathing apparatus</p>
<p><b>Emergency procedures</b> Wear protective clothing and self-contained breathing apparatus.</p> <p><b>Emergency action in the event of fire</b> Nil (non-combustible)</p> <p><b>Medical First Aid</b> Refer to the <i>Medical First Aid Guide (MFAG)</i>, as amended.</p>

**"GYPSUM GRANULATED**

**Description**

Gypsum Granulated made from calcium sulphate hydrate which is produced artificially or industrial by-product. It is produced by granulating and processing such calcium sulphate hydrate until its grain size becomes 10 mm diameter or more. Insoluble in water.

**Characteristics**

<b>Angle of repose</b>	<b>Bulk density (kg/m<sup>3</sup>)</b>	<b>Stowage factor (m<sup>3</sup>/t)</b>
Not applicable	310 to 1,200	0.83 to 3.23
<b>Size</b>	<b>Class</b>	<b>Group</b>
Greater than 10 mm	Not applicable	C

**Hazard**

No special hazards.

This cargo is non-combustible or has a low fire-risk.

**Stowage and segregation**

No special requirements.

**Hold cleanliness**

No special requirements.

**Weather precautions**

No special requirements.

**Loading**

Trim in accordance with the relevant provisions required under sections 4 and 5 of the Code.

**Precautions**

No special requirements.

**Ventilation**

No special requirements.

**Carriage**

No special requirements.

**Discharge**

No special requirements.

**Clean-up**

No special requirements."

**"ILMENITE (ROCK)**

**Description**

Ilmenite (Rock) is obtained from mine blasting followed by crushing. It has a black colour. It may be smelted in electric arc furnaces or can be used in blast furnaces.

**Characteristics**

Angle of repose	Bulk density (kg/m <sup>3</sup> )	Stowage factor (m <sup>3</sup> /t)
Not applicable	2,400 to 3,200	0.31 to 0.42
Size	Class	Group
Up to 100 mm	Not applicable	C

**Hazard**

This cargo has no special hazards.  
This cargo is non-combustible or has a low fire-risk.

**Stowage and segregation**

No special requirements.

**Hold cleanliness**

No special requirements.

### **Weather precautions**

No special requirements.

### **Loading**

Trim in accordance with the relevant provisions required under sections 4 and 5 of the Code. As the density of the cargo is extremely high, the tank top may be overstressed unless the cargo is evenly spread across the tank top to equalize the weight distribution. Due consideration shall be paid to ensure that the tank top is not overstressed during voyage and during loading by a pile of the cargo.

### **Precautions**

Avoid breathing dust. Persons who may be exposed to the dust of the cargo shall wear a dust filter mask, protective eyewear and clothing as necessary.

### **Ventilation**

No special requirements.

### **Carriage**

No special requirements.

### **Discharge**

No special requirements.

### **Clean-up**

No special requirements."

## **"ILMENITE (UPGRADED)**

### **Description**

Ilmenite (upgraded), is obtained from the smelting of rock or sand Ilmenite into electric arc furnaces. Ilmenite (upgraded) has a granular form and its colour varies from black (normal grades) to brown-orange for its purified grade.

Ilmenite (upgraded) is also known as Titanium slag, Titanium Ore Concentrate, Chloride Slag, Sulphate Slag, High Grade Sulphate Slag, Slag fines, Slag ilmenite electro thermal smelting or TiO<sub>2</sub> slag.

### **Characteristics**

<b>Angle of repose</b>	<b>Bulk density (kg/m<sup>3</sup>)</b>	<b>Stowage factor (m<sup>3</sup>/t)</b>
Not applicable	1,860 to 2,400	0.41 to 0.54
<b>Size</b>	<b>Class</b>	<b>Group</b>
Up to 12 mm	Not applicable	A

### **Hazard**

This material may liquefy if shipped at moisture content in excess of its Transportable Moisture Limit (TML). See sections 7 and 8 of this Code.

This cargo is non-combustible or has a low fire-risk.

### **Stowage and segregation**

No special requirements.



### **Hold cleanliness**

No special requirements.

### **Weather precautions**

This cargo shall be kept as dry as practicable before loading, during loading and while on the voyage. When a cargo is carried in a ship other than a specially constructed or fitted cargo ship complying with the requirements in subsection 7.3.2 of this Code, the following provisions shall be complied with:

- .1 the moisture content of the cargo shall be kept less than its TML during loading operations and the voyage;
- .2 unless expressly provided otherwise in this individual schedule, the cargo shall not be handled during precipitation;
- .3 unless expressly provided otherwise in this individual schedule, during handling of the cargo, all non-working hatches of the cargo spaces into which the cargo is loaded or to be loaded shall be closed;
- .4 the cargo may be handled during precipitation under the conditions stated in the procedures required in subsection 4.3.3 of this Code; and
- .5 the cargo in a cargo space may be discharged during precipitation provided that the total amount of the cargo in the cargo space is to be discharged in the port.

### **Loading**

Trim in accordance with the relevant provisions required under sections 4 and 5 of the Code. As the density of the cargo is extremely high, the tank top may be overstressed unless the cargo is evenly spread across the tank top to equalize the weight distribution. Due consideration shall be paid to ensure that the tank top is not overstressed during voyage and during loading by a pile of the cargo.

### **Precautions**

Bilge wells shall be clean, dry and covered as appropriate to prevent ingress of the cargo. Avoid breathing dust. Persons who may be exposed to the dust component of the cargo shall wear personal protective equipment including goggles or other equivalent dust eye-protection and respiratory protection as necessary. Wash hands and face before eating, drinking or smoking.

### **Ventilation**

No special requirements.

### **Carriage**

The appearance of the cargo shall be checked regularly during voyage. If free water above the cargo or fluid state of the cargo is observed during voyage, the master shall take appropriate actions to prevent cargo shifting and potential capsize of the ship, and give consideration to seeking emergency entry into a place of refuge.

### **Discharge**

No special requirements.

### **Clean-up**

No special requirements."

## "NICKEL ORE

### Description

Nickel ore varies in colour. There are several types of ore of variable particle size and moisture content. Some may contain clay-like ores. For concentrates, see NICKEL CONCENTRATE.

### Characteristics

Angle of repose	Bulk density (kg/m <sup>3</sup> )	Stowage factor (m <sup>3</sup> /t)
Not applicable	1,400 to 1,800	0.55 to 0.71
Size	Class	Group
Various	Not applicable	A

### Hazard

This material may liquefy if shipped at a moisture content in excess of its Transportable Moisture Limit (TML). See sections 7 and 8 of this Code. This cargo is non-combustible or has a low fire-risk.

### Stowage and segregation

No special requirements.

### Hold cleanliness

Cargo spaces must be clean and dry.

### Weather precautions

When a cargo is carried in a ship other than a specially constructed or fitted cargo ship complying with the requirements in subsection 7.3.2 of this Code, the following provisions shall be complied with:

- .1 all measures shall be taken during loading operations and the voyage to avoid an increase in the moisture content of the cargo;
- .2 unless expressly provided otherwise in this individual schedule, the cargo shall not be handled during precipitation;
- .3 unless expressly provided otherwise in this individual schedule, during handling of the cargo, all non-working hatches of the cargo spaces into which the cargo is loaded or to be loaded shall be closed;
- .4 the cargo may be handled during precipitation under the conditions stated in the procedures required in subsection 4.3.3 of this Code; and
- .5 the cargo in a cargo space may be discharged during precipitation provided that the total amount of the cargo in the cargo space is to be discharged in the port.

### Loading

Trim in accordance with the relevant provisions required under sections 4 and 5 of the Code.

When the stowage factor of this cargo is equal or less than 0.56 m<sup>3</sup>/t, the tank top may be overstressed unless the cargo is evenly spread across the tank top to equalize the weight distribution. Due consideration shall be given to ensure that the tank top is not overstressed during the voyage and during loading by a pile of the cargo.

### Precautions

Bilge wells shall be clean, dry and covered as appropriate, to prevent ingress of the cargo. The bilge system of a cargo space to which this cargo is to be loaded shall be tested to ensure that it is working.

### Ventilation

The cargo spaces carrying this cargo shall not be ventilated during voyage.

### Carriage

The appearance of the surface of this cargo shall be checked regularly during voyage. If free water above the cargo or fluid state of the cargo is observed during voyage, the master shall take appropriate actions to prevent cargo shifting and potential capsize of the ship, and give consideration to seeking emergency entry into a place of refuge.

### Discharge

No special requirements.

### Clean-up

No special requirements."

## "SAND, HEAVY MINERAL

### Description

The cargo is generally a blend of two or more heavy mineral sands. Such sands are characterized by their heavy bulk density and relatively fine grain size. Abrasive. May be dusty.

### Characteristics

Angle of repose	Bulk density (kg/m <sup>3</sup> )	Stowage factor (m <sup>3</sup> /t)
Not applicable	2,380 to 3,225	0.31 to 0.42
Size	Class	Group
Up to 5 mm	Not applicable	A

### Hazard

This cargo may liquefy if shipped at a moisture content in excess of its TML. See sections 7 and 8 of this Code.

This cargo is non-combustible or has a low fire-risk.

### **Stowage and segregation**

No special requirements.

### **Hold cleanliness**

No special requirements.

### **Weather precautions**

When a cargo is carried in a ship other than a specially constructed or fitted cargo ship complying with the requirements in subsection 7.3.2 of this Code, the following provisions shall be complied with:

- .1 the moisture content of the cargo shall be kept less than its TML during loading operations and the voyage;
- .2 unless expressly provided otherwise in this individual schedule, the cargo shall not be handled during precipitation;
- .3 unless expressly provided otherwise in this individual schedule, during handling of the cargo, all non-working hatches of the cargo spaces into which the cargo is loaded or to be loaded shall be closed;
- .4 the cargo may be handled during precipitation under the conditions stated in the procedures required in subsection 4.3.3 of this Code; and
- .5 the cargo in a cargo space may be discharged during precipitation provided that the total amount of the cargo in the cargo space is to be discharged in the port.

### **Loading**

Trim in accordance with the relevant provisions required under sections 4 and 5 of the Code.

As the density of the cargo is extremely high, the tank top may be overstressed unless the cargo is evenly spread across the tank top to equalize the weight distribution. Due consideration shall be paid to ensure that tank top is not overstressed during voyage and during loading by a pile of the cargo.

### **Precautions**

Bilge wells shall be clean, dry and covered as appropriate, to prevent ingress of the cargo.

### **Ventilation**

No special requirements.

### **Carriage**

The appearance of the surface of this cargo shall be checked regularly during voyage. If free water above the cargo or fluid state of the cargo is observed during voyage, the master shall take appropriate actions to prevent cargo shifting and potential capsizing of the ship, and give consideration to seeking emergency entry into a place of refuge.

**Discharge**

No special requirements.

**Clean-up**

No special requirements."

**"SILICON SLAG**

**Description**

Silicon slag is an odourless greyish metallic material mainly in lump. It is composed of silicon and silicon dioxide in variable proportions.

**Characteristics**

Angle of repose	Bulk density (kg/m <sup>3</sup> )	Stowage factor (m <sup>3</sup> /t)
Not applicable	2,300 to 3,000	0.33 to 0.43
Size	Class	Group
Up to 150 mm	Not applicable	C

**Hazard**

The dust may cause irritation of eyes, skin and upper respiratory tract. This cargo is non-combustible or has a low fire-risk.

**Stowage and segregation**

"Separated from" acids or base materials.

**Hold cleanliness**

No special requirements.

**Weather precautions**

No special requirements.

**Loading**

Trim in accordance with the relevant provisions required under sections 4 and 5 of the Code. As the density of the cargo is extremely high, the tank top may be overstressed unless the cargo is evenly spread across the tank top to equalize the weight distribution. Due consideration shall be paid to ensure that the tank top is not overstressed during the voyage and during the loading process by a pile of the cargo.

**Precautions**

Persons who may be exposed to the dust of the cargo shall wear protective clothing, goggles or other equivalent dust eye-protection and dust filter mask as necessary.

**Ventilation**

No special requirements.

**Carriage**

No special requirements.

**Discharge**

No special requirements.

**Clean-up**

No special requirements."

## "SOLIDIFIED FUELS RECYCLED FROM PAPER AND PLASTICS"

This schedule shall not apply to material classified as dangerous goods (Class 4.2).

### Description

Solidified fuels comprising papers and plastics by compressing or extruding in moulds. The main raw materials of this cargo are waste paper and plastic. Moisture content is 5% or less. Ash content is 10% or less. Total chlorine is 0.3% or less.

### Characteristics

Angle of repose	Bulk density (kg/m <sup>3</sup> )	Stowage factor (m <sup>3</sup> /t)
Not applicable	400 to 500	2.0 to 2.5
Size	Class	Group
Length: 30 to 100 mm Diameter: 15 to 30 mm	MHB	B

### Hazard

Spontaneous ignition is not liable to occur up to 200°C. When ignited, it burns violently. When melted, it generates flammable and toxic gases. Spontaneous-heating may take place and may deplete oxygen in the cargo spaces.

### Stowage and segregation

No special requirements.

### Hold cleanliness

No special requirements.

### Weather precautions

No special requirements.

### Loading

Prior to loading, the manufacturer or shipper shall give the master a certificate stating that the cargo is not class 4.2. Trim in accordance with the relevant provisions required under sections 4 and 5 of the Code.

### Precautions

During handling and carriage, no hot work, burning and smoking shall be permitted in the vicinity of the cargo spaces containing this cargo. After discharging this cargo, entry into cargo spaces shall not be permitted unless they have been sufficiently ventilated.

### Ventilation

The hatches of the cargo spaces shall be closed and the spaces shall not be ventilated during voyage.

### Carriage

Entry into the cargo spaces shall not be permitted during voyage.

### Discharge

The hatches of the cargo spaces shall be opened and sufficiently ventilated prior to entry.

**Clean-up**

No special requirements.

**Emergency procedures**

<p><b>Special emergency equipment to be carried</b> Protective clothing (protective glasses, heat-resistant gloves, coveralls).</p>
<p><b>Emergency procedures</b> Wear protective clothing.</p>
<p><b>Emergency action in the event of fire</b> Batten down; use ship's fixed fire-fighting installation, if fitted. Extinguish fire with water, foam or dry chemicals.</p>
<p><b>Medical First Aid</b> Refer to the Medical First Aid Guide (MFA), as amended.</p>

**"WOOD TORREFIED**

**Description**

Wood torrefied is wood that has been partially burned or roasted and formed into pellets or briquettes. Chocolate brown or black in colour. May contain up to 3% binder.

**Characteristics**

Angle of repose	Bulk density (kg/m <sup>3</sup> )	Stowage factor (m <sup>3</sup> /t)
35° or less	650 to 800	1.25 to 1.54
Size	Class	Group
Pellets with a diameter of 6 to 12 mm. Briquettes with a thickness of 12 to 50 mm and a length and width up to 75 mm.	MHB	B

**Hazard**

Shipments may be subject to oxidation leading to depletion of oxygen and increase of carbon monoxide and carbon dioxide in cargo and adjacent spaces.

Wood torrefied is readily combustible and may self-heat and spontaneously combust.

Handling of wood torrefied may cause dust to develop with a subsequent risk of dust explosion when loading. Dust may cause eye, skin and respiratory irritation.

**Stowage and segregation**

Segregation as for class 4.1 materials.

**Hold cleanliness**

Clean and dry as relevant to the hazards of the cargo.

**Weather precautions**

This cargo shall be kept as dry as practicable. This cargo shall not be handled during precipitation. During handling of this cargo, all non-working hatches of the cargo spaces into which this cargo is loaded or to be loaded shall be closed.

**Loading**

Trim in accordance with the relevant provisions required under sections 4, 5 and 6 of the Code.

**Precautions**

Entry of personnel into cargo and adjacent confined spaces shall not be permitted until tests have been carried out and it has been established that the oxygen content and carbon monoxide levels have been restored to the following levels: oxygen 20.7% and carbon monoxide <100 ppm. If these conditions are not met, additional ventilation shall be applied to the cargo hold or adjacent confined spaces and remeasuring shall be conducted after a suitable interval. An oxygen and carbon monoxide meter shall be worn and activated by all crew when entering cargo and adjacent enclosed spaces.

Persons who may be exposed to the dust of the cargo shall wear protective clothing, goggles or other equivalent dust eye-protection and dust filter masks, as necessary.

**Ventilation**

Ventilation of enclosed spaces adjacent to a cargo hold before entry may be necessary even if these spaces are apparently sealed from the cargo hold.

**Carriage**

Hatches of the cargo spaces carrying this cargo shall be weathertight to prevent the ingress of water.

**Discharge**

No special requirements.

**Clean-up**

No special requirements.

**Emergency procedures**

<p style="text-align: center;"><b>Special emergency equipment to be carried</b> Self-contained breathing apparatus and combined or individual oxygen and carbon monoxide meters should be available.</p>
<p style="text-align: center;"><b>Emergency procedures</b> Nil</p>
<p style="text-align: center;"><b>Emergency action in the event of fire</b> Batten down; use ship's fixed fire-fighting installation, if fitted. Exclusion of air may be sufficient to control fire. Extinguish fire with carbon dioxide, foam or water.</p>
<p style="text-align: center;"><b>Medical First Aid</b> Refer to the Medical First Aid Guide (MFAG), as amended.</p>



**Appendix 3 – Properties of solid bulk cargoes**

**1 Non-cohesive cargoes**

49 In paragraph 1.1, the new following Bulk Cargo Shipping Names are inserted in alphabetical order:

"GRAIN SCREENING PELLETS"

"WOOD TORREFIED"

**Appendix 4 – Index**

50 Include in ALUMINA HYDRATE a synonym as:

"Aluminium hydroxide"

51 Insert an additional name under SAND as:

"

Material	Group	References
Spodumene	C	see SAND

"

52 In the line for SILICOMANGANESE in the line for Material, amend the Bulk Shipping Name to read "SILICOMANGANESE (low carbon)".

53 Include the following names in the alphabetical index:

"

Material	Group	References
ALUMINA HYDRATE	A and B	
ALUMINIUM SMELTING / REMELTING BY-PRODUCTS, PROCESSED	A and B	
CLINKER ASH, WET	A and B	
COAL TAR PITCH	B	
COARSE IRON AND STEEL SLAG AND ITS MIXTURE	C	
CRUSHED CARBON ANODES	C	
GRAIN SCREENING PELLETS	C	
GRANULATED NICKEL MATTE (LESS THAN 2% MOISTURE CONTENT)	B	
GYPSUM GRANULATED	C	
ILMENITE (ROCK)	C	
ILMENITE (UPGRADED)	A	
NICKEL ORE	A	
SAND, HEAVY MINERAL	A	
SILICON SLAG	C	
SOLIDIFIED FUELS RECYCLED FROM PAPER AND PLASTICS	B	
WOOD TORREFIED	B	

"

\*\*\*



**ANNEX 7**

**RESOLUTION MSC.355(92)  
(Adopted on 21 June 2013)**

**AMENDMENTS TO THE INTERNATIONAL CONVENTION  
FOR SAFE CONTAINERS (CSC), 1972**

THE MARITIME SAFETY COMMITTEE,

RECALLING Article 28(b) of the Convention on the International Maritime Organization concerning the functions of the Committee,

NOTING article X of the International Convention for Safe Containers, 1972 (hereinafter referred to as "the Convention"), concerning the special procedure for amending the annexes to the Convention,

HAVING CONSIDERED, at its ninety-second session, proposed amendments to the Convention in accordance with the procedure set forth in paragraphs 1 and 2 of article X of the Convention,

1. ADOPTS the amendments to the annexes of the Convention, the text of which is set out in the annex to the present resolution;
2. DETERMINES, in accordance with paragraph 3 of article X of the Convention, that the said amendments shall enter into force on 1 July 2014 unless, prior to 1 January 2014, five or more of the Contracting Parties notify the Secretary-General of their objection to the amendments;
3. REQUESTS the Secretary-General, in conformity with paragraph 2 of article X of the Convention, to communicate the certified copies of the present resolution and the text of the amendments contained in the annex to all Contracting Parties for their acceptance;
4. ALSO REQUESTS the Secretary-General to inform all Contracting Parties and Members of the Organization of any request and communication under article X of the Convention and of the date on which the amendments enter into force.

\* \* \*

ANNEX

**DRAFT AMENDMENTS TO  
THE INTERNATIONAL CONVENTION FOR SAFE CONTAINERS (CSC), 1972**

**ANNEX I  
REGULATIONS FOR THE TESTING, INSPECTION, APPROVAL  
AND MAINTENANCE OF CONTAINERS**

**Chapter I  
Regulations common to all systems of approval**

- 1 After the heading of chapter I, the following text is inserted:

**"General Provisions**

The following definitions shall be applied for the purpose of this annex:

The letter *g* means the standard acceleration of gravity; *g* equals 9.8 m/s<sup>2</sup>.

The word *load*, when used to describe a physical quantity to which units may be ascribed, signifies mass.

*Maximum operating gross mass or Rating or R* means the maximum allowable sum of the mass of the container and its cargo. The letter *R* is expressed in units of mass. Where the annexes are based on gravitational forces derived from this value, that force, which is an inertial force, is indicated as *Rg*.

*Maximum permissible payload or P* means the difference between maximum operating gross mass or rating and tare. The letter *P* is expressed in units of mass. Where the annexes are based on the gravitational forces derived from this value, that force, which is an inertial force, is indicated as *Pg*.

*Tare* means the mass of the empty container, including permanently affixed ancillary equipment."

**Regulation 1 – Safety Approval Plate**

- 2 Subparagraph 1(b) of regulation 1 is amended as follows:

"(b) On each container, all maximum operating gross mass markings shall be consistent with the maximum operating gross mass information on the Safety Approval Plate.";

- 3 Subparagraph 2(a) is amended as follows:

"(a) The plate shall contain the following information in at least the English or French language:

"CSC SAFETY APPROVAL"

Country of approval and approval reference

Date (month and year) of manufacture

Manufacturer's identification number of the container or, in the case of existing containers for which that number is unknown,

the number allotted by the Administration  
Maximum operating gross mass (kg and lbs)  
Allowable stacking load for 1.8 g (kg and lbs)  
Transverse racking test force (newtons)";

4 At the end of paragraph 3, a new text is added as follows:

", at or before their next scheduled examination or before any other date approved by the Administration, provided this is not later than 1 July 2015.";

5 After the existing paragraph 4, a new paragraph 5 is added as follows:

"5 A container, the construction of which was completed prior to 1 July 2014, may retain the Safety Approval Plate as permitted by the Convention prior to that date as long as no structural modifications occur to that container."

#### **Chapter IV** **Regulations for approval of existing containers** **and new containers not approved at time of manufacture**

##### **Regulation 9 – Approval of existing containers**

6 Subparagraphs 1(c) and 1(e) are amended as follows:

"(c) maximum operating gross mass capability;"

"(e) allowable stacking load for 1.8 g (kg and lbs); and"

##### **Regulation 10 – Approval of new containers not approved at time of manufacture**

7 Subparagraphs (c) and (e) are amended as follows:

"(c) maximum operating gross mass capability;"

"(e) allowable stacking load for 1.8 g (kg and lbs); and"

#### **Appendix**

8 The fourth, fifth and sixth lines of the model of the Safety Approval Plate reproduced in the appendix are amended as follows:

"MAXIMUM OPERATING GROSS MASS ..... kg ..... lbs  
ALLOWABLE STACKING LOAD FOR 1.8 g ..... kg ..... lbs  
TRANSVERSE RACKING TEST FORCE ..... newtons"

9 Items 4 to 8 of the appendix are amended as follows:

"4 Maximum operating gross mass (kg and lbs).

5 Allowable stacking load for 1.8 g (kg and lbs).

6 Transverse racking test force (newtons).

- 7 End-wall strength to be indicated on plate only if end-walls are designed to withstand a force of less or greater than 0.4 times the gravitational force by maximum permissible payload, i.e.  $0.4Pg$ .
- 8 Side-wall strength to be indicated on plate only if the side-walls are designed to withstand a force of less or greater than 0.6 times the gravitational force by maximum permissible payload, i.e.  $0.6Pg$ ."
- 10 The existing paragraphs 10 and 11 are replaced as follows:
- "10 One door off stacking strength to be indicated on plate only if the container is approved for one door off operation. The marking shall show: ALLOWABLE STACKING LOAD ONE DOOR OFF FOR 1.8 g (... kg ... lbs). This marking shall be displayed immediately near the stacking test value (see line 5).
- 11 One door off racking strength to be indicated on plate only if the container is approved for one door off operation. The marking shall show: TRANSVERSE RACKING TEST FORCE (... newtons). This marking shall be displayed immediately near the racking test value (see line 6)."

## ANNEX II STRUCTURAL SAFETY REQUIREMENTS AND TESTS

- 11 After the heading of chapter II, the following text is inserted:

### "General Provisions

The following definitions shall be applied for the purpose of this annex:

The letter *g* means the standard acceleration of gravity; *g* equals  $9.8 \text{ m/s}^2$ .

The word *load*, when used to describe a physical quantity to which units may be ascribed, signifies mass.

*Maximum operating gross mass or Rating or R* means the maximum allowable sum of the mass of the container and its cargo. The letter *R* is expressed in units of mass. Where the annexes are based on gravitational forces derived from this value, that force, which is an inertial force, is indicated as *Rg*.

*Maximum permissible payload or P* means the difference between maximum operating gross mass or rating and tare. The letter *P* is expressed in units of mass. Where the annexes are based on the gravitational forces derived from this value, that force, which is an inertial force, is indicated as *Pg*.

*Tare* means the mass of the empty container, including permanently affixed ancillary equipment."

12 The first sentence of the Introduction to annex II (Structural safety requirements and tests) is amended as follows:

"In setting the requirements of this annex, it is implicit that, in all phases of the operation of containers, the forces as a result of motion, location, stacking and gravitational effect of the loaded container and external forces will not exceed the design strength of the container."

13 In section 1 (Lifting), subsection 1(A) (Lifting from corner fittings) the text concerning test loadings and applied forces is amended as follows:

**"TEST LOAD AND APPLIED FORCES**

**Internal load:**

A uniformly distributed load such that the sum of the mass of container and test load is equal to 2R. In the case of a tank container, when the test load of the internal load plus the tare is less than 2R, a supplementary load, distributed over the length of the tank, is to be added to the container.

**Externally applied forces:**

Such as to lift the sum of a mass of 2R in the manner prescribed (under the heading TEST PROCEDURES)."

14 In section 1 (Lifting), subsection 1(B) (Lifting by any other additional methods) is replaced with the following:

**"TEST LOAD AND APPLIED FORCES**

**TEST PROCEDURES**

**Internal load:**

A uniformly distributed load such that the sum of the mass of container and test load is equal to 1.25R.

**Externally applied forces:**

Such as to lift the sum of a mass of 1.25R in the manner prescribed (under the heading TEST PROCEDURES).

**Internal load:**

A uniformly distributed load such that the sum of the mass of container and test load is equal to 1.25R. In the case of a tank container, when the test load of the internal load plus the tare is less than 1.25R, a supplementary load, distributed over the length of the tank, is to be added to the container.

(i) *Lifting from fork-lift pockets:*

The container shall be placed on bars which are in the same horizontal plane, one bar being centred within each fork-lift pocket which is used for lifting the loaded container. The bars shall be of the same width as the forks intended to be used in the handling, and shall project into the fork pocket 75% of the length of the fork pocket.

(ii) *Lifting from grappler-arm positions:*

The container shall be placed on pads in the same horizontal plane, one under each grappler-arm position. These pads shall be of the same sizes as the lifting area of the grappler arms intended to be used.

**Externally applied forces:**

Such as to lift the sum of a mass of 1.25R in the manner prescribed (under the heading TEST PROCEDURES).

iii) *Other methods:*

Where containers are designed to be lifted in the loaded condition by any method not mentioned in (A) or (B)(i) and (ii) they shall also be tested with the internal load and externally applied forces representative of the acceleration conditions appropriate to that method."

15 Paragraphs 1 and 2 of section 2 (STACKING) are amended as follows:

"1 For conditions of international transport where the maximum vertical acceleration varies significantly from 1.8 g and when the container is reliably and effectively limited to such conditions of transport, the stacking load may be varied by the appropriate ratio of acceleration.

2 On successful completion of this test, the container may be rated for the allowable superimposed static stacking load, which should be indicated on the Safety Approval Plate against the heading ALLOWABLE STACKING LOAD FOR 1.8 g (kg and lbs)."

16 In section 2 (STACKING) the text concerning test loadings and applied forces is amended as follows:

"TEST LOAD AND APPLIED FORCES

**Internal load:**

A uniformly distributed load such that the sum of the mass of container and test load is equal to 1.8R. Tank containers may be tested in the tare condition.

**Externally applied forces:**

Such as to subject each of the four top corner fittings to a vertical downward force equal to 0.25 x 1.8 x the gravitational force of the allowable superimposed static stacking load."



17 Section 3 (CONCENTRATED LOADS) is amended as follows:

"TEST LOAD AND APPLIED FORCES

TEST PROCEDURES

**(a) On roof**

**Internal load:**

None.

The externally applied forces shall be applied vertically downwards to the outer surface of the weakest area of the roof of the container.

**Externally applied forces:**

A concentrated gravitational force of 300 kg (660 lbs) uniformly distributed over an area of 600 mm x 300 mm (24 in x 12 in).

**(b) On floor**

**Internal load:**

Two concentrated loads each of 2,730 kg (6,000 lbs) and each added to the container floor within a contact area of 142 cm<sup>2</sup> (22 sq in).

The test should be made with the container resting on four level supports under its four bottom corners in such a manner that the base structure of the container is free to deflect.

**Externally applied forces:**

None.

A testing device loaded to a mass of 5,460 kg (12,000 lbs), that is, 2,730 kg (6,000 lbs) on each of two surfaces, having, when loaded, a total contact area of 284 cm<sup>2</sup> (44 sq in), that is, 142 cm<sup>2</sup> (22 sq in) on each surface, the surface width being 180 mm (7 in) spaced 760 mm (30 in) apart, centre to centre, should be manoeuvred over the entire floor area of the container.

"

18 The heading and subheading of the text concerning test loadings and applied forces in section 4 (TRANSVERSE RACKING) are replaced with the following respectively:

"TEST LOAD AND APPLIED FORCES" and "**Internal load:**".

19 In section 5 (LONGITUDINAL RESTRAINT (STATIC TEST)), the text concerning test loadings and applied forces is amended as follows:

"TEST LOAD AND APPLIED FORCES

**Internal load:**

A uniformly distributed load, such that the sum of the mass of a container and test load is equal to the maximum operating gross mass or rating R. In the case of a tank container, when the mass of the internal load plus the tare is less than the maximum gross mass or rating, R, a supplementary load is to be added to the container.

**Externally applied forces:**

Such as to subject each side of the container to longitudinal compressive and tensile forces of magnitude  $R_g$ , that is, a combined force of  $2R_g$  on the base of the container as a whole."

20 The first paragraph of section 6 (END-WALLS) is amended as follows:

"The end-walls should be capable of withstanding a force of not less than 0.4 times the force equal to gravitational force by maximum permissible payload. If, however, the end-walls are designed to withstand a force of less or greater than 0.4 times the gravitational force by maximum permissible payload, such a strength factor shall be indicated on the Safety Approval Plate in accordance with annex I, regulation 1."

21 In section 6 (END-WALLS), the text concerning test loadings and applied forces is amended as follows:

"TEST LOAD AND APPLIED FORCES

**Internal load:**

Such as to subject the inside of an end-wall to a uniformly distributed force of  $0.4P_g$  or such other force for which the container may be designed.

**Externally applied forces:**

None."

22 The first paragraph of section 7 (SIDE-WALLS) is amended as follows:

"The side-walls should be capable of withstanding a force of not less than 0.6 times the force equal to the gravitational force by maximum permissible payload. If, however, the side-walls are designed to withstand a force of less or greater than 0.6 times the gravitational force by maximum permissible payload, such a strength factor shall be indicated on the Safety Approval Plate in accordance with annex I, regulation 1."

23 In section 7 (SIDE-WALLS), the text concerning test loadings and applied forces is amended as follows:

"TEST LOAD AND APPLIED FORCES

**Internal load:**

Such as to subject the inside of a side-wall to a uniformly distributed force of  $0.6P_g$  or such other force for which the container may be designed.

**Externally applied forces:** None."

24 The existing section 8 (ONE DOOR OFF OPERATION), is replaced with the following:

**"8 ONE DOOR OFF OPERATION**

8.1 Containers with one door removed have a significant reduction in their ability to withstand racking forces and, potentially, a reduction in stacking strength. The removal of a door on a container in operation is considered a modification of the container. Containers must be approved for one door off operation. Such approval shall be based on test results as set forth below.

8.2 On successful completion of the stacking test the container may be rated for the allowable superimposed stacking load, which shall be indicated on the Safety Approval Plate immediately below line 5: ALLOWABLE STACKING LOAD FOR 1.8 g (kg and lbs) ONE DOOR OFF.

8.3 On successful completion of the racking test the transverse racking test force shall be indicated on the Safety Approval Plate immediately below line 6: TRANSVERSE RACKING TEST FORCE ONE DOOR OFF (newtons).

TEST LOAD AND APPLIED FORCES      TEST PROCEDURES

**Stacking**

**Internal load:**

A uniformly distributed load such that the sum of the mass of container and test load is equal to 1.8R.

The test procedures shall be as set forth under **2 STACKING**

**Externally applied forces:**

Such as to subject each of the four top corner fittings to a vertical downward force equal to  $0.25 \times 1.8 \times$  the gravitational force of the allowable superimposed static stacking load.

**Transverse racking**

**Internal load:**

None.

The test procedures shall be as set forth under **4 TRANSVERSE RACKING**

**Externally applied forces:**

Such as to rack the end structures of the container sideways. The forces shall be equal to those for which the container was designed."

**ANNEX III  
CONTROL AND VERIFICATION**

25 The existing section 4 is replaced with the following:

**"4 Structurally sensitive components**

4.1 The following components are structurally sensitive and should be examined for deficiencies in accordance with the following table:

(i)	(ii)	(iii)	(iv)	(v)	(vi)	(vii)
Structurally sensitive component	Serious deficiency requiring immediate out-of-service determination	Deficiency requiring advice to owner and restrictions for transport	Restrictions to be applied in case of deficiencies according to column (iii)			
			Empty container		Loaded container	
			Sea transport	Other modes	Sea transport	Other modes
<b>Top rail</b>	Local deformation to the rail in excess of 60 mm or separation or cracks or tears in the rail material in excess of 45 mm in length. (see Note 1)	Local deformation to the rail in excess of 40 mm or separation or cracks or tears in the rail material in excess of 10 mm in length. (see Note 1)	No restriction	No restriction	Bottom lifting not allowed, Top lifting allowed only by use of spreaders without chains	Bottom lifting not allowed, Top lifting allowed only by use of spreaders without chains
Note 1: On some designs of tank containers the top rail is not a structurally significant component.						
<b>Bottom rail</b>	Local deformation perpendicular to the rail in excess of 100 mm or separation cracks or tears in the rail's material in excess of 75 mm in length (see Note 2)	Local deformation perpendicular to the rail in excess of 60 mm or separation cracks or tears in the rail's material: in excess of 25 mm in length in the upper flange; or b) of web in any length (see Note 2)	No restriction	No restriction	Lifting at (any) corner fitting not allowed	Lifting at (any) corner fitting not allowed
Note 2: The rails material does not include the rail's bottom flange.						
<b>Header</b>	Local deformation to the header in excess of 80 mm or cracks or tears in excess of 80 mm in length	Local deformation to the header in excess of 50 mm or cracks or tears in excess of 10 mm in length	Container shall not be overstowed	No restriction	Container shall not be overstowed	No restriction

(i)	(ii)	(iii)	(iv)	(v)	(vi)	(vii)
Structurally sensitive component	Serious deficiency requiring immediate out-of-service determination	Deficiency requiring advice to owner and restrictions for transport	Restrictions to be applied in case of deficiencies according to column (iii)			
			Empty container		Loaded container	
			Sea transport	Other modes	Sea transport	Other modes
<b>Sill</b>	Local deformation to the sill in excess of 100 mm or cracks or tears in excess of 100 mm in length.	Local deformation to the sill in excess of 60 mm or cracks or tears in excess of 10 mm in length	Container shall not be overstowed	No restrictions	Container shall not be overstowed	No restrictions
<b>Corner posts</b>	Local deformation to the post in excess of 50 mm or cracks or tears in excess of 50 mm in length	Local deformation to the post in excess of 30 mm or cracks or tears of any length	Container shall not be overstowed	No restrictions	Container shall not be overstowed	No restrictions
<b>Corner and intermediate fittings</b>	Missing corner fittings, any through cracks or tears in the fitting, any deformation of the fitting that precludes full engagement of the securing or lifting fittings (see Note 3) or any weld separation of adjoining components in excess of 50 mm in length	Weld separation of adjoining components of 50 mm or less	Container shall not be lifted on board a ship if the damaged fittings prevent safe lifting or securing.	Container shall be lifted and handled with special care	Container shall not be loaded on board a ship.	Container shall be lifted and handled with special care
		Any reduction in the thickness of the plate containing the top aperture that makes it less than 25 mm thick	Container shall be lifted and handled with special care Container shall not be overstowed when twistlocks have to be used	Container shall be lifted and handled with special care	Container shall not be lifted by the top corner fittings.	Container shall be lifted and handled with special care.
		Any reduction in the thickness of the plate containing the top aperture that makes it less than 26 mm thick	Container shall not be overstowed when fully automatic twistlocks are to be used	Container shall be lifted and handled with special care	Container shall not be used with fully automatic twistlocks.	Container shall be lifted and handled with special care.

(i)	(ii)	(iii)	(iv)	(v)	(vi)	(vii)
Structurally sensitive component	Serious deficiency requiring immediate out-of-service determination	Deficiency requiring advice to owner and restrictions for transport	Restrictions to be applied in case of deficiencies according to column (iii)			
			Empty container		Loaded container	
			Sea transport	Other modes	Sea transport	Other modes
<p>Note 3 The full engagement of securing or lifting fittings is precluded if there is any deformation of the fitting beyond 5 mm from its original plane, any aperture width greater than 66 mm, any aperture length greater than 127 mm or any reduction in thickness of the plate containing the top aperture that makes it less than 23 mm thick.</p>						
Understructure	Two or more adjacent cross members missing or detached from the bottom rails. 20% or more of the total number of cross members missing or detached. (see Note 4)	One or two cross members missing or detached (see Note 4)	No restrictions	No restrictions	No restrictions	No restrictions
		More than two cross members missing or detached (see Notes 4 and 5)	No restrictions	No restrictions	Maximum payload shall be restricted to 0.5 x P	Maximum payload shall be restricted to 0.5 x P
<p>Note 4: If onward transport is permitted, it is essential that detached cross members are precluded from falling free.</p>						
<p>Note 5: Careful cargo discharge is required as forklift capability of the understructure might be limited.</p>						
Locking rods	One or more inner locking rods are non-functional (see Note 6)	One or more outer locking rods are non-functional (see Note 6)	Container shall not be overstowed	No restriction	Container shall not be overstowed. Cargo shall be secured against the container frame and the door shall not be used to absorb acceleration forces – otherwise maximum payload shall be restricted to 0.5 P	Cargo shall be secured against the container frame and the door shall not be used to absorb acceleration forces – otherwise maximum payload shall be restricted to 0.5 P
<p>Note 6: Some containers are designed and approved (and so recorded on the CSC Plate) to operate with one door open or removed.</p>						

\*\*\*





**ANNEX 8**

**RESOLUTION MSC.356(92)  
(Adopted on 21 June 2013)**

**AMENDMENTS TO THE PROTOCOL OF 1988 RELATING TO  
THE INTERNATIONAL CONVENTION ON LOAD LINES, 1966, AS AMENDED**

THE MARITIME SAFETY COMMITTEE,

RECALLING Article 28(b) of the Convention on the International Maritime Organization concerning the functions of the Committee,

RECALLING ALSO article VI of the Protocol of 1988 relating to the International Convention on Load Lines, 1966 (hereinafter referred to as the "1988 Load Lines Protocol") concerning amendment procedures,

NOTING the proposed amendments to the 1988 Load Lines Protocol to make the Code for recognized organizations (RO Code) mandatory,

HAVING CONSIDERED, at its ninety-second session, amendments to the 1988 Load Lines Protocol proposed and circulated in accordance with paragraph 2(a) of article VI thereof,

1. ADOPTS, in accordance with paragraph 2(d) of article VI of the 1988 Load Lines Protocol, amendments to the 1988 Load Lines Protocol, the text of which is set out in the annex to the present resolution;
2. DETERMINES, in accordance with paragraph 2(f)(ii)(bb) of article VI of the 1988 Load Lines Protocol, that the said amendments shall be deemed to have been accepted on 1 July 2014, unless, prior to that date, more than one third of the Parties to the 1988 Load Lines Protocol or Parties the combined merchant fleets of which constitute not less than 50 per cent of the gross tonnage of all the merchant fleets of all Parties, have notified their objections to the amendments;
3. INVITES the Parties concerned to note that, in accordance with paragraph 2(g)(ii) of article VI of the 1988 Load Lines Protocol, the amendments shall enter into force on 1 January 2015 upon their acceptance in accordance with paragraph 2 above;
4. REQUESTS the Secretary-General, in conformity with paragraph 2(e) of article VI of the 1988 Load Lines Protocol, to transmit certified copies of the present resolution and the text of the amendments contained in the annex to all Parties to the 1988 Load Lines Protocol;
5. ALSO REQUESTS the Secretary-General to transmit copies of this resolution and its annex to Members of the Organization, which are not Parties to the 1988 Load Lines Protocol.

\* \* \*

ANNEX

**AMENDMENTS TO ANNEX B TO THE PROTOCOL OF 1988 RELATING TO  
THE INTERNATIONAL CONVENTION ON LOAD LINES, 1966, AS AMENDED**

**ANNEX I**

**Regulations for determining load lines**

**Chapter I**

**General**

**Regulation 2-1 – Authorization of recognized organizations**

1 The existing text of regulation 2-1 is replaced with the following:

"The Administration shall authorize organizations, including classification societies, referred to in article 13 of the Convention and regulation 1(2) in accordance with the provisions of the present Convention and with the Code for Recognized Organizations (RO Code), consisting of part 1 and part 2 (the provisions of which shall be treated as mandatory) and part 3 (the provisions of which shall be treated as recommendatory), as adopted by the Organization by resolution MSC.349(92), as may be amended by the Organization, provided that:

- (a) amendments to part 1 and part 2 of the RO Code are adopted, brought into force and take effect in accordance with the provisions of article VI of the present Protocol;
- (b) amendments to part 3 of the RO Code are adopted by the Maritime Safety Committee in accordance with its Rules of Procedure; and
- (c) any amendments adopted by the Maritime Safety Committee and the Marine Environment Protection Committee are identical and come into force or take effect at the same time, as appropriate."

\*\*\*

**ANNEX 9**

**RESOLUTION MSC.357(92)  
(Adopted on 21 June 2013)**

**AMENDMENTS TO THE CODE FOR THE CONSTRUCTION AND EQUIPMENT  
OF MOBILE OFFSHORE DRILLING UNITS (MODU CODE)**

THE MARITIME SAFETY COMMITTEE,

RECALLING Article 28(b) of the Convention on the International Maritime Organization concerning the functions of the Committee,

RECALLING ALSO that the Assembly, when adopting resolution A.414(XI) on the *Code for the Construction and Equipment of Mobile Offshore Drilling Units* (MODU Code), authorized the Committee to amend the Code as necessary after due consultation with relevant organizations as the Committee deems necessary,

RECOGNIZING the need for introduction into this Code of provisions for enclosed space entry and rescue drills,

HAVING CONSIDERED, at its ninety-second session, the recommendations made by the Sub-Committee on Dangerous Goods, Solid Cargoes and Containers, at its seventeenth session,

1. ADOPTS amendments to the MODU Code, set out in the annex to the present resolution;
2. INVITES all Governments concerned to take appropriate steps to give effect to the annexed amendments to the Code by 1 January 2015.

\* \* \*

ANNEX

**AMENDMENTS TO THE CODE FOR THE CONSTRUCTION AND EQUIPMENT  
OF MOBILE OFFSHORE DRILLING UNITS (MODU CODE)**

- 1 After subsection 10.6.3 "Emergency drills", insert new subsection 10.6.4 as follows:  
**"10.6.4 Enclosed space entry and rescue drills**
  - .1 Crew members with enclosed space entry or rescue responsibilities should participate in an enclosed space entry and rescue drill to be held on board the unit, at least once every two months.
  - .2 Enclosed space entry and rescue drills should be planned and conducted in a safe manner, taking into account, as appropriate, the guidance provided in the recommendations developed by the Organization\*.  

---

\* Refer to the *Revised recommendations for entering enclosed spaces aboard ships* (resolution A.1050(27)).
  - .3 Each enclosed space entry and rescue drill should include:
    - .1 checking and use of personal protective equipment required for entry;
    - .2 checking and use of communication equipment and procedures;
    - .3 checking and use of instruments for measuring the atmosphere in enclosed spaces;
    - .4 checking and use of rescue equipment and procedures; and
    - .5 instructions in first aid and resuscitation techniques."
- 2 Renumber existing subsection 10.6.4 as 10.6.5.
- 3 After existing section 14.4, insert new sections 14.5 and 14.6 as follows:  
**"14.5 Procedures for entry into enclosed spaces**

Written procedures for entry into enclosed spaces should be provided which should take into account, as appropriate, the guidance provided in recommendations developed by the Organization .

---

\* Refer to the *Revised recommendations for entering enclosed spaces aboard ships* (resolution A.1050(27)).

  
**14.6 Records**

The date when musters and enclosed space entry and rescue drills are held, details of abandonment drills, drills of other life-saving appliances and onboard training should be recorded in such logbook as may be prescribed by the Administration. If a full muster, drill or training session is not held at the appointed time, an entry should be made in the logbook stating the circumstances and the extent of the muster, drill or training session held."
- 4 Renumber existing sections 14.5 to 14.7 as 14.7 to 14.9, respectively.

\*\*\*

**ANNEX 10**

**RESOLUTION MSC.358(92)  
(Adopted on 21 June 2013)**

**AMENDMENTS TO THE CODE FOR THE CONSTRUCTION AND EQUIPMENT OF  
MOBILE OFFSHORE DRILLING UNITS, 1989 (1989 MODU CODE)**

THE MARITIME SAFETY COMMITTEE,

RECALLING Article 28(b) of the Convention on the International Maritime Organization concerning the functions of the Committee,

RECALLING ALSO that the Assembly, when adopting resolution A.649(16) on the *Code for the Construction and Equipment of Mobile Offshore Drilling Units, 1989* (1989 MODU Code), authorized the Committee to amend the Code, when appropriate, taking into consideration the developing design and safety features after due consultation with appropriate organizations,

RECOGNIZING the need for introduction into this Code of provisions for enclosed space entry and rescue drills,

HAVING CONSIDERED, at its ninety-second session, the recommendations made by the Sub-Committee on Dangerous Goods, Solid Cargoes and Containers, at its seventeenth session,

1. ADOPTS amendments to the 1989 MODU Code, set out in the annex to the present resolution;
2. INVITES all Governments concerned to take appropriate steps to give effect to the annexed amendments to the 1989 MODU Code by 1 January 2015.

\* \* \*

ANNEX

**AMENDMENTS TO THE CODE FOR THE CONSTRUCTION AND EQUIPMENT  
OF MOBILE OFFSHORE DRILLING UNITS, 1989 (1989 MODU CODE)**

- 1 After existing section 14.4, insert new section 14.5 as follows:

**"14.5 Procedures for entry into enclosed spaces**

Written procedures for entry into enclosed spaces should be provided which should take into account, as appropriate, the guidance provided in recommendations developed by the Organization .

\* Refer to the *Revised recommendations for entering enclosed spaces aboard ships* (resolution A.1050(27))."

- 2 Renumber existing sections 14.5 to 14.11 as 14.6 to 14.12, respectively.

- 3 After renumbered section 14.12, insert new section 14.13 as follows:

**"14.13 Enclosed space entry and rescue drills**

- .1 Crew members with enclosed space entry or rescue responsibilities should participate in an enclosed space entry and rescue drill to be held on board the unit at least once every two months.
- .2 Enclosed space entry and rescue drills should be planned and conducted in a safe manner, taking into account, as appropriate, the guidance provided in the recommendations developed by the Organization\*.

\* Refer to the *Revised recommendations for entering enclosed spaces aboard ships* (resolution A.1050(27)).

- .3 Each enclosed space entry and rescue drill should include:

- .1 checking and use of personal protective equipment required for entry;
- .2 checking and use of communication equipment and procedures;
- .3 checking and use of instruments for measuring the atmosphere in enclosed spaces;
- .4 checking and use of rescue equipment and procedures; and
- .5 instructions in first aid and resuscitation techniques."

4 Renumber existing section 14.13 as 14.14 and amend it to read:

**"14.14 Records**

The date when musters and enclosed space entry and rescue drills are held, details of abandonment drills, drills of other life-saving appliances and onboard training should be recorded in such logbook as may be prescribed by the Administration. If a full muster, drill or training session is not held at the appointed time, an entry should be made in the logbook stating the circumstances and the extent of the muster, drill or training session held."

5 In the existing paragraphs 14.8.9 and 14.11.3, references to the renumbered paragraphs are updated.

\*\*\*





**ANNEX 11**

**RESOLUTION MSC.359(92)  
(Adopted on 21 June 2013)**

**AMENDMENTS TO THE CODE FOR THE CONSTRUCTION AND EQUIPMENT  
OF MOBILE OFFSHORE DRILLING UNITS, 2009 (2009 MODU CODE)**

THE MARITIME SAFETY COMMITTEE,

RECALLING Article 28(b) of the Convention on the International Maritime Organization concerning the functions of the Committee,

RECALLING ALSO that the Assembly, when adopting resolution A.1023(26) on the *Code for the Construction and Equipment of Mobile Offshore Drilling Units, 2009 (2009 MODU Code)*, authorized the Committee to amend the Code as appropriate, taking into consideration development in the design and technologies, in consultation with appropriate organizations,

RECOGNIZING the need for introduction into this Code of provisions for enclosed space entry and rescue drills,

HAVING CONSIDERED, at its ninety-second session, the recommendations made by the Sub-Committee on Dangerous Goods, Solid Cargoes and Containers, at its seventeenth session,

1. ADOPTS amendments to the 2009 MODU Code, set out in the annex to the present resolution;
2. INVITES all Governments concerned to take appropriate steps to give effect to the annexed amendments to the 2009 MODU Code by 1 January 2015.

\* \* \*

ANNEX

**AMENDMENTS TO THE CODE FOR THE CONSTRUCTION AND EQUIPMENT OF  
MOBILE OFFSHORE DRILLING UNITS, 2009 (2009 MODU CODE)**

- 1 After existing section 14.6, insert new section 14.7 as follows:

**"14.7 Procedures for entry into enclosed spaces**

Written procedures for entry into enclosed spaces should be provided which should take into account, as appropriate, the guidance provided in recommendations developed by the Organization .

\* Refer to the *Revised recommendations for entering enclosed spaces aboard ships* (resolution A.1050(27))."

- 2 Renumber existing sections 14.7 to 14.12 as 14.8 to 14.13, respectively.

- 3 After renumbered section 14.13, insert new section 14.14 to read:

**"14.14 Enclosed space entry and rescue drills**

.1 Crew members with enclosed space entry or rescue responsibilities should participate in an enclosed space entry and rescue drill to be held on board the unit at least once every two months. If a full drill is not held at the appointed time, an entry should be made in the official log or tour record stating the circumstances and the extent of the drill held.

.2 Enclosed space entry and rescue drills should be planned and conducted in a safe manner, taking into account, as appropriate, the guidance provided in the recommendations developed by the Organization .

\* Refer to the *Revised recommendations for entering enclosed spaces aboard ships* (resolution A.1050(27)).

.3 Each enclosed space entry and rescue drill should include:

.1 checking and use of personal protective equipment required for entry;

.2 checking and use of communication equipment and procedures;

.3 checking and use of instruments for measuring the atmosphere in enclosed spaces;

.4 checking and use of rescue equipment and procedures; and

.5 instructions in first aid and resuscitation techniques."

- 4 Renumber existing sections 14.13 and 14.14 as 14.15 and 14.16, respectively.
- 5 In renumbered section 14.16 "Records", amend paragraph 14.16.1.2 to read:  
  
"14.16.1.2 drills and exercises under paragraph 14.10.2 and sections 14.13 and 14.14."
- 6 In the existing paragraphs 14.1.2, 14.9.9, 14.12.3 and 14.14.2, references to the renumbered paragraphs are updated.

\*\*\*



**ANNEX 12**

**RESOLUTION MSC.360(92)  
(Adopted on 21 June 2013)**

**AMENDMENTS TO THE CODE OF SAFETY FOR DYNAMICALLY  
SUPPORTED CRAFT (DSC CODE)**

THE MARITIME SAFETY COMMITTEE,

RECALLING Article 28(b) of the Convention on the International Maritime Organization concerning the functions of the Committee,

RECALLING ALSO that the Assembly, when adopting resolution A.373(X) on the *Code of Safety for Dynamically Supported Craft* (DSC Code), authorized the Committee to amend the Code as may be necessary,

RECOGNIZING the need for introduction into this Code of provisions for enclosed space entry and rescue drills,

HAVING CONSIDERED, at its ninety-second session, the recommendations made by the Sub-Committee on Dangerous Goods, Solid Cargoes and Containers, at its seventeenth session,

1. ADOPTS amendments to the DSC Code, set out in the annex to the present resolution;
2. INVITES all Governments concerned to take appropriate steps to give effect to the annexed amendments to the Code by 1 January 2015.

\* \* \*

ANNEX

**AMENDMENTS TO THE CODE OF SAFETY FOR DYNAMICALLY  
SUPPORTED CRAFT (DSC CODE)**

Insert a new paragraph in chapter 17 "Operational requirements" as follows:

"17.5.4 Personnel with enclosed space entry or rescue responsibilities should participate in an enclosed space entry and rescue drill, to be held on board the craft, at least once every two months. Enclosed space entry and rescue drills should be planned and conducted in a safe manner, taking into account, as appropriate, the guidance provided in the recommendations developed by the Organization .

\* Refer to the *Revised recommendations for entering enclosed spaces aboard ships* (resolution A.1050(27))."

\*\*\*

## ANNEX 13

### DRAFT AMENDMENTS TO SOLAS CHAPTER II-2

#### CHAPTER II-2 CONSTRUCTION – PROTECTION, FIRE DETECTION AND FIRE EXTINCTION

##### Part A – General

##### Regulation 1 – Application

1 The following new paragraph 2.6 is added after existing paragraph 2.5:

"2.6 Vehicle carriers constructed before [*date of entry into force*] shall comply with paragraph 2.2 of regulation 20-1, as adopted by resolution [MSC....(....)]."

##### Regulation 3 – Definitions

2 The following three new paragraphs are added after paragraph 53:

"54 *Fire damper* is a device installed in a ventilation duct, which under normal conditions remains open allowing flow in the duct, and is closed during a fire, preventing the flow in the duct to restrict the passage of fire. In using the above definition the following terms may be associated:

- .1 *automatic fire damper* is a fire damper that closes independently in response to exposure to fire products;
- .2 *manual fire damper* is a fire damper that is intended to be opened or closed by the crew by hand at the damper itself; and
- .3 *remotely operated fire damper* is a fire damper that is closed by the crew through a control located at a distance away from the controlled damper.

55 *Smoke damper* is a device installed in a ventilation duct, which under normal conditions remains open allowing flow in the duct, and is closed during a fire, preventing the flow in the duct to restrict the passage of smoke and hot gases. A smoke damper is not expected to contribute to the integrity of a fire rated division penetrated by a ventilation duct. In using the above definition the following terms may be associated:

- .1 *automatic smoke damper* is a smoke damper that closes independently in response to exposure to smoke or hot gases.
- .2 *manual smoke damper* is a smoke damper intended to be opened or closed by the crew by hand at the damper itself.
- .3 *remotely operated smoke damper* is a smoke damper that is closed by the crew through a control located at a distance away from the controlled damper.

56 *Vehicle carrier* means a cargo ship with multi deck ro-ro spaces designed for the carriage of empty cars and trucks as cargo."

## Part B – Prevention of fire and explosion

### Regulation 4 – Probability of ignition

3 The existing paragraph 5.5 is replaced by the following:

#### **"5.5 Inert gas systems**

##### **5.5.1 Application**

5.5.1.1 For tankers of 20,000 tonnes deadweight and upwards constructed on or after 1 July 2002 but before [*date of entry into force*], the protection of the cargo tanks shall be achieved by a fixed inert gas system in accordance with the requirements of the Fire Safety Systems Code, as adopted by resolution MSC.98(73), except that the Administration may accept other equivalent systems or arrangements, as described in paragraph 5.5.4.

5.5.1.2 For tankers of 8,000 tonnes deadweight and upwards constructed on or after [*date of entry into force*] when carrying cargoes described in regulation 1.6.1 or 1.6.2, the protection of the cargo tanks shall be achieved by a fixed inert gas system in accordance with the requirements of the Fire Safety Systems Code, except that the Administration may accept other equivalent systems or arrangements, as described in paragraph 5.5.4.

5.5.1.3 Tankers operating with a cargo tank cleaning procedure using crude oil washing shall be fitted with an inert gas system complying with the Fire Safety Systems Code and with fixed tank washing machines. However, inert gas systems fitted on tankers constructed on or after 1 July 2002 but before [*date of entry into force*] shall comply with the Fire Safety Systems Code, as adopted by resolution MSC.98(73).

5.5.1.4 Tankers required to be fitted with inert gas systems shall comply with the following provisions:

- .1 double-hull spaces shall be fitted with suitable connections for the supply of inert gas;
- .2 where hull spaces are connected to a permanently fitted inert gas distribution system, means shall be provided to prevent hydrocarbon gases from the cargo tanks entering the double hull spaces through the system; and
- .3 where such spaces are not permanently connected to an inert gas distribution system, appropriate means shall be provided to allow connection to the inert gas main.

##### **5.5.2 Inert gas systems of chemical tankers and gas carriers**

5.5.2.1 The requirements for inert gas systems contained in the Fire Safety Systems Code need not be applied to chemical tankers and gas carriers constructed before [*date of entry into force*]:



- .1 when carrying cargoes described in regulation 1.6.1, provided that they comply with the requirements for inert gas systems on chemical tankers established by the Administration, based on the guidelines developed by the Organization<sup>\*</sup>; or

<sup>\*</sup> Refer to the *Regulation for inert gas systems on chemical tankers*, adopted by the Organization by resolution A.567(14), and Corr.1.

- .2 when carrying flammable cargoes other than crude oil or petroleum products such as cargoes listed in chapters 17 and 18 of the International Bulk Chemical Code, provided that the capacity of tanks used for their carriage does not exceed 3,000 m<sup>3</sup> and the individual nozzle capacities of tank washing machines do not exceed 17.5 m<sup>3</sup>/h and the total combined throughput from the number of machines in use in a cargo tank at any one time does not exceed 110 m<sup>3</sup>/h.

### 5.5.3 General requirements for inert gas systems

5.5.3.1 The inert gas system shall be capable of inerting, purging and gas-freeing empty tanks and maintaining the atmosphere in cargo tanks with the required oxygen content.

[5.5.3.2 The inert gas system referred to in paragraph 5.5.3.1 shall be designed, constructed and tested in accordance with the Fire Safety Systems Code.]

5.5.3.4 Tankers fitted with a fixed inert gas system shall be provided with a closed ullage system.

### 5.5.4 Requirements for equivalent systems

5.5.4.1 The Administration may, after having given consideration to the ship's arrangement and equipment, accept other fixed installations, in accordance with regulation I/5 and paragraph 5.5.4.3.

5.5.4.2 For tankers of 8,000 tonnes deadweight and upwards but less than 20,000 tonnes deadweight constructed on or after [*date of entry into force*], the Administration may accept other equivalent arrangements or means of protection in lieu of fixed installations, in accordance with regulation I/5 and paragraph 5.5.4.3.

5.5.4.3 Equivalent systems or arrangements shall:

- .1 be capable of preventing dangerous accumulations of explosive mixtures in intact cargo tanks during normal service throughout the ballast voyage and necessary in-tank operations; and
- .2 be so designed as to minimize the risk of ignition from the generation of static electricity by the system itself."

## Part C – Suppression of fire

### Regulation 9 - Containment of fire

4 Paragraph 7 is replaced by the following:

#### "7 Ventilation systems

(This paragraph applies to ships constructed on or after [*date of entry into force*].)

#### 7.1 General

7.1.1 Ventilation ducts, including single and double wall ducts, shall be of steel or equivalent material. Unless expressly provided otherwise in paragraph 7.1.6, any other material used in the construction of ducts, including insulation, shall also be non-combustible. However, short ducts, not generally exceeding 2 m in length and with a free cross-sectional area\* not exceeding 0.02 m<sup>2</sup>, need not be of steel or equivalent material, subject to the following conditions:

- .1 the ducts shall be made of heat resisting non-combustible material, which may be faced internally and externally with membranes having low flame-spread characteristics and, in each case, a calorific value\*\* not exceeding 45 MJ/m<sup>2</sup> of their surface area for the thickness used;
- .2 the ducts are only used at the end of the ventilation device; and
- .3 the ducts are not situated less than 600 mm, measured along the duct, from an opening in an "A" or "B" class division, including continuous "B" class ceiling.

---

\* The term *free cross-sectional area* means, even in the case of a pre-insulated duct, the area calculated on the basis of the inner dimensions of the duct itself and not the insulation.

\*\* Refer to the recommendations published by the International Organization for Standardization, in particular publication ISO 1716:2002, Reaction to the fire tests for building products – Determination of the heat of combustion.

7.1.2 The following arrangements shall be tested in accordance with the Fire Test Procedures Code:

- .1 fire dampers, including their relevant means of operation, however, the testing is not required for dampers located at the lower end of the duct in exhaust ducts for galley ranges, which must be of steel and capable of stopping the draught in the duct; and
- .2 duct penetrations through "A" class divisions. However, the test is not required where steel sleeves are directly joined to ventilation ducts by means of riveted or screwed connections or by welding.

7.1.3 Fire dampers shall be easily accessible. Where they are placed behind ceilings or linings, these ceilings or linings shall be provided with an inspection hatch on which the identification number of the fire damper is marked. The fire damper identification number shall also be marked on any remote controls provided.

7.1.4 Ventilation ducts shall be provided with hatches for inspection and cleaning. The hatches shall be located near the fire dampers.

7.1.5 The main inlets and outlets of ventilation systems shall be capable of being closed from outside the spaces being ventilated. The means of closing shall be easily accessible as well as prominently and permanently marked and shall indicate the operating position of the closing device.

7.1.6 Combustible gaskets in flanged ventilation duct connections are not permitted within 600 mm of openings in "A" or "B" class divisions and in ducts required to be of "A" class construction.

7.1.7 Ventilation openings or air balance ducts between two enclosed spaces shall not be provided except as permitted by paragraphs II-2/9.4.1.2.1 and II-2/9.4.2.3.

## **7.2 Arrangement of ducts**

7.2.1 The ventilation systems for machinery spaces of category A, vehicle spaces, ro-ro spaces, galleys, special category spaces and cargo spaces shall, in general, be separated from each other and from the ventilation systems serving other spaces. However, the galley ventilation systems on cargo ships of a gross tonnage of less than 4,000 and in passenger ships carrying not more than 36 passengers need not be completely separated from other ventilation systems, but may be served by separate ducts from a ventilation unit serving other spaces. In such a case, an automatic fire damper shall be fitted in the galley ventilation duct near the ventilation unit.

7.2.2 Ducts provided for the ventilation of machinery spaces of category A, galleys, vehicle spaces, ro-ro spaces or special category spaces shall not pass through accommodation spaces, service spaces, or control stations unless they comply with paragraph 7.2.4.

7.2.3 Ducts provided for the ventilation of accommodation spaces, service spaces or control stations shall not pass through machinery spaces of category A, galleys, vehicle spaces, ro-ro spaces or special category spaces unless they comply with paragraph 7.2.4.

7.2.4 As permitted by paragraphs 7.2.2 and 7.2.3 ducts shall be:

- .1 constructed of steel having a thickness of at least 3 mm for ducts with a free cross-sectional area of less than 0.075 m<sup>2</sup>, at least 4 mm for ducts with a free cross-sectional area of between 0.075 m<sup>2</sup> and 0.45 m<sup>2</sup>, and at least 5 mm for ducts with a free cross-sectional area of over 0.45 m<sup>2</sup>;
- .2 suitably supported and stiffened;
- .3 fitted with automatic fire dampers close to the boundaries penetrated; and
- .4 insulated to "A-60" class standard from the boundaries of the spaces they serve to a point at least 5 m beyond each fire damper;

or

- .5 constructed of steel in accordance with paragraphs 7.2.4.1.1 and 7.2.4.1.2; and
- .6 insulated to "A-60" class standard throughout the spaces they pass through, except for ducts that pass through spaces of category (9) or (10) as defined in paragraph 9.2.2.3.2.2.

7.2.5 For the purposes of paragraphs 7.2.4.4 and 7.2.4.6, ducts shall be insulated over their entire cross-sectional external surface. Ducts that are outside but adjacent to the specified space, and share one or more surfaces with it, shall be considered to pass through the specified space, and shall be insulated over the surface they share with the space for a distance of 450 mm past the duct\*.

---

\* Sketches of such arrangements are contained in the Unified Interpretations of SOLAS chapter II-2 (MSC.1/Circ.1276).

7.2.6 Where it is necessary that a ventilation duct passes through a main vertical zone division, an automatic fire damper shall be fitted adjacent to the division. The damper shall also be capable of being manually closed from each side of the division. The control location shall be readily accessible and be clearly and prominently marked. The duct between the division and the damper shall be constructed of steel in accordance with paragraphs 7.2.4.1 and 7.2.4.2 and insulated to at least the same fire integrity as the division penetrated. The damper shall be fitted on at least one side of the division with a visible indicator showing the operating position of the damper.

### **7.3 Details of fire dampers and duct penetrations**

7.3.1 Ducts passing through "A" class divisions shall meet the following requirements:

- .1 Where a thin plated duct with a free cross sectional area equal to, or less than, 0.02 m<sup>2</sup> passes through "A" class divisions, the opening shall be fitted with a steel sheet sleeve having a thickness of at least 3 mm and a length of at least 200 mm, divided preferably into 100 mm on each side of a bulkhead or, in the case of a deck, wholly laid on the lower side of the decks penetrated.
- .2 Where ventilation ducts with a free cross-sectional area exceeding 0.02 m<sup>2</sup>, but not more than 0.075 m<sup>2</sup>, pass through "A" class divisions, the openings shall be lined with steel sheet sleeves. The ducts and sleeves shall have a thickness of at least 3 mm and a length of at least 900 mm. When passing through bulkheads, this length shall be divided preferably into 450 mm on each side of the bulkhead. These ducts, or sleeves lining such ducts, shall be provided with fire insulation. The insulation shall have at least the same fire integrity as the division through which the duct passes.

- .3 Automatic fire dampers shall be fitted in all ducts with a free cross-sectional area exceeding  $0.075 \text{ m}^2$  that pass through "A" class divisions. Each damper shall be fitted close to the division penetrated and the duct between the damper and division penetrated shall be constructed of steel in accordance with paragraphs 7.2.4.5 and 7.2.4.6. The fire damper shall operate automatically, but shall also be capable of being closed manually from both sides of the division. The damper shall be fitted with a visible indicator which shows the operating position of the damper. Fire dampers are not required, however, where ducts pass through spaces surrounded by "A" class divisions, without serving those spaces, provided those ducts have the same fire integrity as the divisions which they penetrate. A duct of cross-sectional area exceeding  $0.075 \text{ m}^2$  shall not be divided into smaller ducts at the penetration of an "A" class division and then recombined into the original duct once through the division to avoid installing the damper required by this provision.

7.3.2 Ventilation ducts with a free cross-sectional area exceeding  $0.02 \text{ m}^2$  passing through "B" class bulkheads shall be lined with steel sheet sleeves of 900 mm in length, divided preferably into 450 mm on each side of the bulkheads unless the duct is of steel for this length.

7.3.3 All fire dampers shall be capable of manual operation. The dampers shall have a direct mechanical means of release or, alternatively, be closed by electrical, hydraulic, or pneumatic operation. All dampers shall be manually operable from both sides of the division. Automatic fire dampers, including those capable of remote operation, shall have a failsafe mechanism that will close the damper in a fire even upon loss of electrical power or hydraulic or pneumatic pressure loss. Remotely operated fire dampers shall be capable of being reopened manually at the damper.

#### **7.4 Ventilation systems for passenger ships carrying more than 36 passengers**

7.4.1 In addition to the requirements in sections 7.1, 7.2 and 7.3, the ventilation system of a passenger ship carrying more than 36 passengers shall also meet the following requirements.

7.4.2 In general, the ventilation fans shall be so arranged that the ducts reaching the various spaces remain within a main vertical zone.

7.4.3 Stairway enclosures shall be served by an independent ventilation fan and duct system (exhaust and supply) which shall not serve any other spaces in the ventilation systems.

7.4.4 A duct, irrespective of its cross-section, serving more than one 'tween-deck accommodation space, service space or control station, shall be fitted, near the penetration of each deck of such spaces, with an automatic smoke damper that shall also be capable of being closed manually from the protected deck above the damper. Where a fan serves more than one 'tween-deck space through separate ducts within a main vertical zone, each dedicated to a single 'tween-deck space, each duct shall be provided with a manually operated smoke damper fitted close to the fan.

7.4.5 Vertical ducts shall, if necessary, be insulated as required by tables 9.1 and 9.2. Ducts shall be insulated as required for decks between the space they serve and the space being considered, as applicable.

## **7.5 Exhaust ducts from galley ranges**

### **7.5.1 Requirements for passenger ships carrying more than 36 passengers**

7.5.1.1 In addition to the requirements in sections 7.1, 7.2 and 7.3, exhaust ducts from galley ranges shall be constructed in accordance with paragraphs 7.2.4.5 and 7.2.4.6 and insulated to "A-60" class standard throughout accommodation spaces, service spaces, or control stations they pass through. They shall also be fitted with:

- .1 a grease trap readily removable for cleaning unless an alternative approved grease removal system is fitted;
- .2 a fire damper located in the lower end of the duct at the junction between the duct and the galley range hood which is automatically and remotely operated and, in addition, a remotely operated fire damper located in the upper end of the duct close to the outlet of the duct;
- .3 a fixed means for extinguishing a fire within the duct<sup>\*</sup>;
- .4 remote-control arrangements for shutting off the exhaust fans and supply fans, for operating the fire dampers mentioned in paragraph 7.5.1.1.2 and for operating the fire-extinguishing system, which shall be placed in a position outside the galley close to the entrance to the galley. Where a multi-branch system is installed, a remote means located with the above controls shall be provided to close all branches exhausting through the same main duct before an extinguishing medium is released into the system; and
- .5 suitably located hatches for inspection and cleaning, including one provided close to the exhaust fan and one fitted in the lower end where grease accumulates.

---

<sup>\*</sup> Refer to the recommendations published by the International Organization for Standardization, in particular publication ISO 15371:2009, Ships and marine technology – Fire-extinguishing systems for protection of galley cooking equipment.

7.5.1.2 Exhaust ducts from ranges for cooking equipment installed on open decks shall conform to paragraph 7.5.1.1, as applicable, when passing through accommodation spaces or spaces containing combustible materials.

### **7.5.2 Requirements for cargo ships and passenger ships carrying not more than 36 passengers**

When passing through accommodation spaces or spaces containing combustible materials, the exhaust ducts from galley ranges shall be constructed in accordance with paragraphs 7.2.4.1 and 7.2.4.2. Each exhaust duct shall be fitted with:

- .1 a grease trap readily removable for cleaning;
- .2 an automatically and remotely operated fire damper located in the lower end of the duct at the junction between the duct and the galley range hood and, in addition, a remotely operated fire damper in the upper end of the duct close to the outlet of the duct;
- .3 arrangements, operable from within the galley, for shutting off the exhaust and supply fans; and
- .4 fixed means for extinguishing a fire within the duct.\*

\* Refer to the recommendations published by the International Organization for Standardization, in particular publication ISO 15371:2009, Ships and marine technology – Fire-extinguishing systems for protection of galley cooking equipment.

## **7.6 Ventilation rooms serving machinery spaces of category A containing internal combustion machinery**

7.6.1 Where a ventilation room serves only such an adjacent machinery space and there is no fire division between the ventilation room and the machinery space, the means for closing the ventilation duct or ducts serving the machinery space shall be located outside of the ventilation room and machinery space.

7.6.2 Where a ventilation room serves such a machinery space as well as other spaces and is separated from the machinery space by a "A-0" class division, including penetrations, the means for closing the ventilation duct or ducts for the machinery space can be located in the ventilation room. In this case, the ventilation ducts shall be dedicated to the machinery space in question.

## **7.7 Ventilation systems for laundries in passenger ships carrying more than 36 passengers**

Exhaust ducts from laundries and drying rooms of category (13) spaces as defined in paragraph 9.2.2.3.2.2 shall be fitted with:

- .1 filters readily removable for cleaning purposes;
- .2 a fire damper located in the lower end of the duct which is automatically and remotely operated;
- .3 remote-control arrangements for shutting off the exhaust fans and supply fans from within the space and for operating the fire damper mentioned in paragraph 7.7.1.2; and
- .4 suitably located hatches for inspection and cleaning."

## **Regulation 10 – Fire fighting**

5 Paragraph 1 (Purpose), is replaced by the following:

"1.1 The purpose of this regulation is to suppress and swiftly extinguish a fire in the space of origin, except for paragraph 1.2. For this purpose, the following functional requirements shall be met:

- .1 fixed fire-extinguishing systems shall be installed having due regard to the fire growth potential of the protected spaces; and
- .2 fire-extinguishing appliances shall be readily available.

1.2 For open-top container holds\* and on deck container stowage areas on ships designed to carry containers on or above the weather deck, constructed on or after [date of entry into force], fire protection arrangements shall be provided for the purpose of containing a fire in the space or area of origin and cooling adjacent areas to prevent fire spread and structural damage.

---

\* For a definition of this term, refer to the Interim guidelines for open-top containerships (MSC/Circ.608/Rev.1)."

6 In paragraph 2.1.3, add the words ",other than those included in paragraph 7.3.2," between the words "cargo ships" and "the diameter".

7 In paragraph 2.2.4.1.2, add the words ",other than those included in paragraph 7.3.2," between the words "cargo ship" and "need".

8 The following new paragraph 7.3 is added after existing paragraph 7.2:

"7.3 *Fire fighting for ships designed to carry containers on or above the weather deck, constructed on or after [date of entry into force]*

7.3.1 Ships shall carry, in addition to the equipment and arrangements required by regulations 10.1 and 10.2, at least one water mist lance.

7.3.1.1 The water mist lance shall consist of a tube with a piercing nozzle which is capable of penetrating a container wall and producing water mist inside a confined space (container, etc.) when connected to the fire main.

7.3.2 Ships designed to carry five or more tiers of containers on or above the weather deck shall carry, in addition to the requirements of paragraph 7.3.1, mobile water monitors\* as follows:

ships with breadth up to 30 m:	at least two mobile water monitors
ships with breadth of 30 m or more:	at least four mobile water monitors

---

\* Refer to the *Guidelines for the design, performance, testing and approval of mobile water monitors used for the protection of on-deck cargo areas of ships designed and constructed to carry five or more tiers of containers on or above the weather deck* (MSC.1/Circ...).

7.3.2.1 The mobile water monitors, all necessary hoses, fittings and required fixing hardware shall be kept ready for use in a location outside the cargo space area not likely to be cut-off in the event of a fire in the cargo spaces.

7.3.2.2 A sufficient number of fire hydrants shall be provided such that:

- .1 all provided mobile water monitors can be operated simultaneously for creating effective water barriers forward and aft of each container bay;



- .2 the two jets of water required by paragraph 2.1.5.1 can be supplied at the pressure required by paragraph 2.1.6; and
- .3 each of the required mobile water monitors can be supplied by separate hydrants at the pressure necessary to reach the top tier of containers on deck.

7.3.2.3 The mobile water monitors may be supplied by the fire main, provided the capacity of fire pumps and fire main diameter are adequate to simultaneously operate the mobile water monitors and two jets of water from fire hoses at the required pressure values. If carrying dangerous goods, the capacity of fire pumps and fire main diameter shall also comply with regulation 19.3.1.5, as far as applicable to on-deck cargo areas.

7.3.2.4 The operational performance of each mobile water monitor shall be tested during initial survey on board the ship to the satisfaction of the Administration. The test shall verify that:

- .1 the mobile water monitor can be securely fixed to the ship structure ensuring safe and effective operation; and
- .2 the mobile water monitor jet reaches the top tier of containers with all required monitors and water jets from fire hoses operated simultaneously."

## **Part D – Escape**

### **Regulation 13 – Means of escape**

9 The following new subparagraph 4.1.1.3 is added after existing subparagraph 4.1.1.2, and a semi-colon and the word "and" are added at the end of subparagraph 4.1.1.2:

- "3 all inclined ladders/stairways with open treads in machinery spaces being part of or providing access to escape routes but not located within a protected enclosure shall be made of steel. Such ladders/stairways shall be fitted with steel shields attached to their undersides, such as to provide escaping personnel protection against heat and flame from beneath."

10 The following new paragraph 4.1.5 is inserted after existing paragraph 4.1.4:

#### *"4.1.5 Escape from main workshops within machinery spaces*

Two means of escape shall be provided from the main workshop within a machinery space. At least one of these escape routes shall provide a continuous fire shelter to a safe position outside the machinery space."

11 In the first sentence of paragraph 4.2.1, the words "paragraph 4.2.2" are replaced with the words "paragraph 4.2.4".

12 The following new subparagraph 4.2.1.3 is added after existing subparagraph 4.2.1.2, and a semi-colon and the word "and" are added at the end of subparagraph 4.2.1.2:

"3 all inclined ladders/stairways with open treads in machinery spaces being part of or providing access to escape routes but not located within a protected enclosure shall be made of steel. Such ladders/stairways shall be fitted with steel shields attached to their undersides, such as to provide escaping personnel protection against heat and flame from beneath."

13 The following new paragraphs 4.2.2 and 4.2.3 are inserted after existing paragraph 4.2.1 and the following paragraphs are renumbered accordingly:

"4.2.2 *Escape from machinery control rooms in machinery spaces of category "A"*

Two means of escape shall be provided from the machinery control room located within a machinery space. At least one of these escape routes shall provide a continuous fire shelter to a safe position outside the machinery space.

4.2.3 *Escape from main workshops in machinery spaces of category "A"*

Two means of escape shall be provided from the main workshop within a machinery space. At least one of these escape routes shall provide a continuous fire shelter to a safe position outside the machinery space."

## **Part E – Operational requirements**

### **Regulation 16 – Operations**

14 Insert a new paragraph 3.3 after the existing paragraph 3.2 as follows:

#### **"3.3 Operation of inert gas system**

3.3.1 The inert gas system for tankers required in accordance with regulation 4.5.5.1 shall be so operated as to render and maintain the atmosphere of the cargo tanks non-flammable, except when such tanks are required to be gas-free.

3.3.2 Notwithstanding the above, for chemical tankers, the application of inert gas, may take place after the cargo tank has been loaded, but before commencement of unloading and shall continue to be applied until that cargo tank has been purged of all flammable vapours before gas-freeing. Only nitrogen is acceptable as inert gas under this provision.

3.3.3 If the oxygen content of the inert gas exceeds 5 per cent by volume, immediate action shall be taken to improve the gas quality. Unless the quality of the gas improves, all operations in those cargo tanks to which inert gas is being supplied shall be suspended so as to avoid air being drawn into the cargo tanks, the gas regulating valve, if fitted, shall be closed and the off-specification gas shall be vented to atmosphere.

3.3.4 In the event that the inert gas system is unable to meet the requirement in paragraph 16.3.3.1 and it has been assessed that it is impracticable to effect a repair, then cargo discharge and cleaning of those cargo tanks requiring inerting shall only be resumed when suitable emergency procedures have been followed, taking into account guidelines developed by the Organization\*.

---

\* Refer to the Clarification of inert gas system requirements under the Convention (MSC/Circ.485) and to the *Revised Guidelines for inert gas systems* (MSC/Circ.353), as amended by MSC/Circ.387."

## Part G – Special requirements

### Regulation 18 – Helicopter facilities

15 Paragraphs 5.1.3 to 5.1.5 are replaced by the following, and the remaining paragraphs are renumbered accordingly:

- "3 a foam application system in accordance with the guidelines developed by the Organization";

<sup>\*</sup> Refer to the *Guidelines for the approval of helicopter facility foam fire-fighting appliances* (MSC.1/Circ.1431)."

16 The following new regulation 20-1 is added after existing regulation 20:

### **"Regulation 20-1 – Requirements for vehicle carriers carrying motor vehicles with compressed hydrogen or natural gas in their tanks for their own propulsion as cargo**

#### **1 Purpose**

The purpose of this regulation is to provide additional safety measures in order to address the fire safety objectives of this chapter for vehicle carriers with vehicle and ro-ro spaces intended for carriage of motor vehicles with compressed hydrogen or compressed natural gas in their tanks for their own propulsion as cargo.

#### **2 Application**

2.1 In addition to complying with the requirements of regulation 20, as appropriate, vehicle spaces of a vehicle carrier constructed on or after [*date of entry into force*] intended for the carriage of motor vehicles with compressed hydrogen or compressed natural gas in their tanks for their own propulsion as cargo shall comply with the requirements in paragraphs 3 to 5 of this regulation.

2.2 In addition to complying with the requirements of regulation 20, as appropriate, a vehicle carrier constructed before [*date of entry into force*] shall comply with the requirements in paragraph 5 of this regulation.

#### **3 Requirements for spaces intended for carriage of motor vehicles with compressed natural gas in their tanks for their own propulsion as cargo**

##### **3.1 Electrical equipment and wiring**

All electrical equipment and wiring shall be of a certified safe type for use in an explosive methane and air mixture\*.

<sup>\*</sup> Refer to the recommendations of the International Electrotechnical Commission, in particular, publication IEC 60079.

##### **3.2 Ventilation arrangement**

3.2.1 Electrical equipment and wiring, if installed in any ventilation duct, shall be of a certified safe type for use in explosive methane and air mixtures.

3.2.2 The fans shall be such as to avoid the possibility of ignition of methane and air mixtures. Suitable wire mesh guards shall be fitted over inner and outlet ventilation openings.

### **3.3 Other ignition sources**

Other equipment which may constitute a source of ignition of methane and air mixtures shall not be permitted.

## **4 Requirements for spaces intended for carriage of motor vehicles with compressed hydrogen in their tanks for their own propulsion as cargo**

### **4.1 Electrical equipment and wiring**

All electrical equipment and wiring shall be of a certified safe type for use in an explosive hydrogen and air mixture\*.

\* Refer to the recommendations of the International Electrotechnical Commission, in particular, publication IEC 60079.

### **4.2 Ventilation arrangement**

4.2.1 Electrical equipment and wiring, if installed in any ventilation duct, shall be of a certified safe type for use in explosive hydrogen and air mixtures and the outlet from any exhaust duct shall be sited in a safe position, having regard to other possible sources of ignition.

4.2.2 The fans shall be designed such as to avoid the possibility of ignition of hydrogen and air mixtures. Suitable wire mesh guards shall be fitted over inner and outlet ventilation openings.

### **4.3 Other ignition sources**

Other equipment which may constitute a source of ignition of hydrogen and air mixtures shall not be permitted.

## **5 Detection**

When a vehicle carrier carries as cargo one or more motor vehicles with either compressed hydrogen or compressed natural gas in their tanks for their own propulsion, at least two portable gas detectors shall be provided. Such detectors shall be suitable for the detection of the gas fuel and be of a certified safe type for use in the explosive gas and air mixture."

\*\*\*

## ANNEX 14

### DRAFT AMENDMENTS TO THE INTERNATIONAL CODE FOR FIRE SAFETY SYSTEMS (FSS CODE)

#### CHAPTER 15 INERT GAS SYSTEMS

The text of existing chapter 15 is replaced by the following:

#### **1 Application**

This chapter details the specifications for inert gas systems as required by chapter II-2 of the Convention.

#### **2 Engineering specifications**

##### **2.1 Definitions**

For the purposes of this chapter:

2.1.1 *Cargo tanks* means those cargo tanks, including slop tanks, which carry cargoes, or cargo residues, having a flashpoint not exceeding 60°C.

2.1.2 *Inert gas system* includes inert gas systems using flue gas, inert gas generators, and nitrogen generators and means the inert gas plant and inert gas distribution together with means for preventing backflow of cargo gases to machinery spaces, fixed and portable measuring instruments and control devices.

2.1.3 *Gas-safe space* is a space in which the entry of gases would produce hazards with regard to flammability or toxicity.

2.1.4 *Gas-free* is a condition in a tank where the content of hydrocarbon or other flammable vapour is less than 1 per cent of the lower flammable limit (LFL), the oxygen content is at least 21 per cent, and no toxic gases are present\*.

---

\* Refer to the *Revised Recommendations for entering enclosed spaces aboard ships* (resolution A.1050(27)).

##### **2.2 Requirements for all systems**

###### **2.2.1 General**

2.2.1.1 The inert gas system referred to in chapter II-2 of the Convention shall be designed, constructed and tested to the satisfaction of the Administration. It shall be designed to be capable of rendering and maintaining the atmosphere of the relevant cargo tanks non-flammable\*.

---

\* Refer to the *Revised Standards for the design, testing and locating of devices to prevent the passage of flame into cargo tanks in tankers* (MSC/Circ.677, as amended by MSC/Circ.1009 and MSC.1/Circ.1324) and the *Revised Factors to be taken into consideration when designing cargo tank venting and gas-freeing arrangements* (MSC/Circ.731).

2.2.1.2 The system shall be capable of:

- .1 inerting empty cargo tanks and maintaining the atmosphere in any part of the tank with an oxygen content not exceeding 8 per cent by volume and at a positive pressure in port and at sea except when it is necessary for such a tank to be gas-free;
- .2 eliminating the need for air to enter a tank during normal operations except when it is necessary for such a tank to be gas-free;
- .3 purging empty cargo tanks of hydrocarbon or other flammable vapours, so that subsequent gas-freeing operations will at no time create a flammable atmosphere within the tank;
- .4 delivering inert gas to the cargo tanks at a rate of at least 125 per cent of the maximum rate of discharge capacity of the ship expressed as a volume. For chemical tankers and chemical/product tankers, the Administration may accept inert gas systems having a lower delivery capacity provided that the maximum rate of discharge of cargoes from cargo tanks being protected by the system is restricted to not more than 80 per cent of the inert gas capacity; and
- .5 delivering inert gas with an oxygen content of not more than 5 per cent by volume to the cargo tanks at any required rate of flow.

2.2.1.3 Materials used in inert gas systems shall be suitable for their intended purpose. In particular, those components which may be subjected to corrosive action of the gases and/or liquids are to be either constructed of corrosion-resistant material or lined with rubber, glass fibre epoxy resin or other equivalent coating material.

2.2.1.4 The inert gas supply may be:

- .1 treated flue gas from main or auxiliary boilers, or
- .2 gas from an oil or gas-fired gas generator, or
- .3 gas from nitrogen generators.

The Administration may accept systems using inert gases from one or more separate gas generators or other sources or any combination thereof, provided that an equivalent level of safety is achieved. Such systems shall, as far as practicable, comply with the requirements of this chapter. Systems using stored carbon dioxide shall not be permitted unless the Administration is satisfied that the risk of ignition from generation of static electricity by the system itself is minimized.

## **2.2.2 Safety measures**

2.2.2.1 The inert gas system shall be so designed that the maximum pressure which it can exert on any cargo tank will not exceed the test pressure of any cargo tank.

2.2.2.2 Automatic shutdown of the inert gas system and its components parts shall be arranged on predetermined limits being reached, taking into account the provisions of paragraphs 2.2.4, 2.3.2 and 2.4.2.

2.2.2.3 Suitable shutoff arrangements shall be provided on the discharge outlet of each generator plant.

2.2.2.4 The system shall be designed to ensure that if the oxygen content exceeds 5 per cent by volume, the inert gas shall be automatically vented to atmosphere.

2.2.2.5 Arrangements shall be provided to enable the functioning of the inert gas plant to be stabilized before commencing cargo discharge. If blowers are to be used for gas-freeing, their air inlets shall be provided with blanking arrangements.

2.2.2.6 Where a double block and bleed valve is installed, the system shall ensure upon loss of power, the block valves are automatically closed and the bleed valve is automatically open.

### **2.2.3 System components**

#### *2.2.3.1 Non-return devices*

2.2.3.1.1 At least two non-return devices shall be fitted in order to prevent the return of vapour and liquid to the inert gas plant, or to any gas-safe spaces.

2.2.3.1.2 The first non-return device shall be a deck seal of the wet, semi-wet, or dry type or a double-block and bleed arrangement. Two shut-off valves in series with a venting valve in between, may be accepted provided:

- .1 the operation of the valve is automatically executed. Signal(s) for opening/closing is (are) to be taken from the process directly, e.g. inert gas flow or differential pressure; and
- .2 alarm for faulty operation of the valves is provided, e.g. the operation status of "blower stop" and "supply valve(s) open" is an alarm condition.

2.2.3.1.3 The second non-return device shall be a non-return valve or equivalent capable of preventing the return of vapours and liquids and fitted between the deck water seal (or equivalent device) and the first connection from the inert gas main to a cargo tank. It shall be provided with positive means of closure. As an alternative to positive means of closure, an additional valve having such means of closure may be provided between the non-return valve and the first connection to the cargo tanks to isolate the deck water seal, or equivalent device, from the inert gas main to the cargo tanks.

2.2.3.1.4 A water seal, if fitted, shall be capable of being supplied by two separate pumps, each of which shall be capable of maintaining an adequate supply at all times. The audible and visual alarm on the low level of water in the water seal shall operate at all times.

2.2.3.1.5 The arrangement of the water seal, or equivalent devices, and its associated fittings shall be such that it will prevent backflow of vapours and liquids and will ensure the proper functioning of the seal under operating conditions.

2.2.3.1.6 Provision shall be made to ensure that the water seal is protected against freezing, in such a way that the integrity of seal is not impaired by overheating.

2.2.3.1.7 A water loop or other approved arrangement shall also be fitted to each associated water supply and drain pipe and each venting or pressure-sensing pipe leading to gas-safe spaces. Means shall be provided to prevent such loops from being emptied by vacuum.

2.2.3.1.8 Any water seal, or equivalent device, and loop arrangements shall be capable of preventing return of vapours and liquids to an inert gas plant at a pressure equal to the test pressure of the cargo tanks.

2.2.3.1.9 The non-return devices shall be located in the cargo area on deck.

#### 2.2.3.2 *Inert gas lines*

2.2.3.2.1 The inert gas main may be divided into two or more branches forward of the non-return devices required by paragraph 2.2.3.1.

2.2.3.2.2 The inert gas main shall be fitted with branch piping leading to the cargo tank. Branch piping for inert gas shall be fitted with either stop valves or equivalent means of control for isolating each tank. Where stop valves are fitted, they shall be provided with locking arrangements. The control system shall provide unambiguous information of the operational status of such valves to at least the control panel required in paragraph 2.2.4.

2.2.3.2.3 Each cargo tank not being inerted shall be capable of being separated from the inert gas main by:

- .1 removing spool-pieces, valves or other pipe sections, and blanking the pipe ends; or
- .2 arrangement of two spectacle flanges in series with provisions for detecting leakage into the pipe between the two spectacle flanges; or
- .3 equivalent arrangements to the satisfaction of the Administration, providing at least the same level of protection.

2.2.3.2.4 Means shall be provided to protect cargo tanks against the effect of overpressure or vacuum caused by thermal variations and/or cargo operations when the cargo tanks are isolated from the inert gas mains.

2.2.3.2.5 Piping systems shall be so designed as to prevent the accumulation of cargo or water in the pipelines under all normal conditions.

2.2.3.2.6 Arrangements shall be provided to enable the inert gas main to be connected to an external supply of inert gas. The arrangements shall consist of a 250 mm nominal pipe size bolted flange, isolated from the inert gas main by a valve and located forward of the non-return valve. The design of the flange should conform to the appropriate class in the standards adopted for the design of other external connections in the ship's cargo piping system.

2.2.3.2.7 If a connection is fitted between the inert gas main and the cargo piping system, arrangements shall be made to ensure an effective isolation having regard to the large pressure difference which may exist between the systems. This shall consist of two shutoff valves with an arrangement to vent the space between the valves in a safe manner or an arrangement consisting of a spool-piece with associated blanks.



2.2.3.2.8 The valve separating the inert gas main from the cargo main and which is on the cargo main side shall be a non-return valve with a positive means of closure.

2.2.3.2.9 Inert gas piping systems shall not pass through accommodation, service and control station spaces.

2.2.3.2.10 In combination carriers, the arrangement to isolate the slop tanks containing oil or oil residues from other tanks shall consist of blank flanges which will remain in position at all times when cargoes other than oil are being carried except as provided for in the relevant section of the guidelines developed by the Organization\*.

---

\* Refer to the Revised Guidelines for inert gas systems (MSC/Circ.353), as amended by MSC/Circ.387.

## **2.2.4 Indicators and alarms**

2.2.4.1 The operation status of the inert gas system shall be indicated in a control panel.

2.2.4.2 Instrumentation shall be fitted for continuously indicating and permanently recording, when inert gas is being supplied:

- .1 the pressure of the inert gas mains forward of the non-return devices; and
- .2 the oxygen content of the inert gas.

2.2.4.3 The indicating and recording devices shall be placed in the cargo control room where provided. But where no cargo control room is provided, they shall be placed in a position easily accessible to the officer in charge of cargo operations.

2.2.4.4 In addition, meters shall be fitted:

- .1 in the navigating bridge to indicate at all times the pressure referred to in paragraph 2.2.4.2.1 and the pressure in the slop tanks of combination carriers, whenever those tanks are isolated from the inert gas main; and
- .2 in the machinery control room or in the machinery space to indicate the oxygen content referred to in paragraph 2.2.4.2.2.

### **2.2.4.5 Audible and visual alarms**

2.2.4.5.1 Audible and visual alarms shall be provided, based on the system designed, to indicate:

- .1 oxygen content in excess of 5 per cent by volume;
- .2 failure of the power supply to the indicating devices as referred to in paragraph 2.2.4.2;
- .3 gas pressure less than 100 mm water gauge. The alarm arrangement shall be such as to ensure that the pressure in slop tanks in combination carriers can be monitored at all times;

- .4 high-gas pressure; and
- .5 failure of the power supply to the automatic control system.

2.2.4.5.2 The alarms required in paragraphs 2.2.4.5.1.1, 2.2.4.5.1.3 and 2.2.4.5.1.5 shall be fitted in the machinery space and cargo control room, where provided, but in each case in such a position that they are immediately received by responsible members of the crew.

2.2.4.5.3 An audible alarm system independent of that required in paragraph 2.2.4.5.1.3 or automatic shutdown of cargo pumps shall be provided to operate on predetermined limits of low pressure in the inert gas main being reached.

2.2.4.5.4 Two oxygen sensors shall be positioned at appropriate locations in the space or spaces containing the inert gas system. If the oxygen level falls below 19 per cent, these sensors shall trigger alarms, which shall be both visible and audible inside and outside the space or spaces and shall be placed in such a position that they are immediately received by responsible members of the crew.

### **2.2.5 Instruction manuals**

Detailed instruction manuals shall be provided on board, covering the operations, safety and maintenance requirements and occupational health hazards relevant to the inert gas system and its application to the cargo tank system.\* The manuals shall include guidance on procedures to be followed in the event of a fault or failure of the inert gas system.

---

\* Refer to the *Revised Guidelines for inert gas systems* (MSC/Circ.353), as amended by MSC/Circ.387.

## **2.3 Requirements for flue gas and inert gas generator systems**

In addition to the provisions in paragraph 2.2, for inert gas systems using flue gas or inert gas generators, the provisions of this section shall apply.

### **2.3.1 System requirements**

#### **2.3.1.1 Inert gas generators**

2.3.1.1.1 Two fuel oil pumps shall be fitted to the inert gas generator. Suitable fuel in sufficient quantity shall be provided for the inert gas generators.

2.3.1.1.2 The inert gas generators shall be located outside the cargo tank area. Spaces containing inert gas generators shall have no direct access to accommodation service or control station spaces, but may be located in machinery spaces. If they are not located in machinery spaces, such a compartment shall be separated by a gastight steel bulkhead and/or deck from accommodation, service and control station spaces. Adequate positive-pressure-type mechanical ventilation shall be provided for such a compartment.

#### **2.3.1.2 Gas regulating valves**

2.3.1.2.1 A gas regulating valve shall be fitted in the inert gas main. This valve shall be automatically controlled to close, as required in paragraph 2.2.2.2. It shall

also be capable of automatically regulating the flow of inert gas to the cargo tanks unless means are provided to automatically control the inert gas flow rate.

2.3.1.2.2 The gas regulating valve shall be located at the forward bulkhead of the forward most gas-safe space through which the inert gas main passes.

#### 2.3.1.3 *Cooling and scrubbing arrangement*

2.3.1.3.1 Means shall be fitted which will effectively cool the volume of gas specified in paragraph 2.2.1.2 and remove solids and sulphur combustion products. The cooling water arrangements shall be such that an adequate supply of water will always be available without interfering with any essential services on the ship. Provision shall also be made for an alternative supply of cooling water.

2.3.1.3.2 Filters or equivalent devices shall be fitted to minimize the amount of water carried over to the inert gas blowers.

#### 2.3.1.4 *Blowers*

2.3.1.4.1 At least two inert gas blowers shall be fitted and be capable of delivering to the cargo tanks at least the volume of gas required by paragraph 2.2.1.2. For systems fitted with inert gas generators the Administration may permit only one blower if that system is capable of delivering the total volume of gas required by paragraph 2.2.1.2 to the cargo tanks, provided that sufficient spares for the blower and its prime mover are carried on board to enable any failure of the blower and its prime mover to be rectified by the ship's crew.

2.3.1.4.2 Where inert gas generators are served by positive displacement blowers, a pressure relief device shall be provided to prevent excess pressure being developed on the discharge side of the blower.

2.3.1.4.3 When two blowers are provided, the total required capacity of the inert gas system shall be divided evenly between the two and in no case is one blower to have a capacity less than 1/3 of the total required.

#### 2.3.1.5 *Inert gas isolating valves*

For systems using flue gas, flue gas isolating valves shall be fitted in the inert gas mains between the boiler uptakes and the flue gas scrubber. These valves shall be provided with indicators to show whether they are open or shut, and precautions shall be taken to maintain them gas-tight and keep the seatings clear of soot. Arrangements shall be made to ensure that boiler soot blowers cannot be operated when the corresponding flue gas valve is open.

#### 2.3.1.6 *Prevention of flue gas leakage*

2.3.1.6.1 Special consideration shall be given to the design and location of scrubber and blowers with relevant piping and fittings in order to prevent flue gas leakages into enclosed spaces.

2.3.1.6.2 To permit safe maintenance, an additional water seal or other effective means of preventing flue gas leakage shall be fitted between the flue gas isolating valves and scrubber or incorporated in the gas entry to the scrubber.

### **2.3.2 Indicators and alarms**

2.3.2.1 In addition to the requirements in paragraph 2.2.4.2, means shall be provided for continuously indicating the temperature of the inert gas at the discharge side of the system, whenever it is operating.

2.3.2.2 In addition to the requirements of paragraph 2.2.4.5, audible and visual alarms shall be provided to indicate:

- .1 insufficient fuel oil supply to the oil-fired inert gas generator;
- .2 failure of the power supply to the generator;
- .3 low water pressure or low water flow rate to the cooling and scrubbing arrangement;
- .4 high water level in the cooling and scrubbing arrangement;
- .5 high gas temperature;
- .6 failure of the inert gas blowers; and
- .7 low water level in the water seal.

## **2.4 Requirements for nitrogen generator systems**

In addition to the provisions in paragraph 2.2, for inert gas systems using nitrogen generators, the provisions of this section shall apply.

### **2.4.1 System requirements**

2.4.1.1 The system shall be provided with one or more compressors to generate enough positive pressure to be capable of delivering the total volume of gas required by paragraph 2.2.1.2.

2.4.1.2 A feed air treatment system shall be fitted to remove free water, particles and traces of oil from the compressed air.

2.4.1.3 The air compressor and nitrogen generator may be installed in the engine-room or in a separate compartment. A separate compartment and any installed equipment shall be treated as an "Other machinery space" with respect to fire protection. Where a separate compartment is provided for the nitrogen generator, the compartment shall be fitted with an independent mechanical extraction ventilation system providing six air changes per hour. The compartment is to have no direct access to accommodation spaces, service spaces and control stations.

2.4.1.4 Where a nitrogen receiver or a buffer tank is installed, it may be installed in a dedicated compartment, in a separate compartment containing the air compressor and the generator, in the engine room, or in the cargo area. Where the nitrogen receiver or a buffer tank is installed in an enclosed space, the access shall be arranged only from the open deck and the access door shall open outwards. Adequate, independent mechanical ventilation, of the extraction type, shall be provided for such a compartment.

## **2.4.2 Indicators and alarms**

2.4.2.1 In addition to the requirements in paragraph 2.2.4.2, instrumentation is to be provided for continuously indicating the temperature and pressure of air at the suction side of the nitrogen generator.

2.4.2.2 In addition to the requirements in paragraph 2.2.4.5, audible and visual alarms shall be provided to include:

- .1 failure of the electric heater, if fitted;
- .2 low feed-air pressure or flow from the compressor;
- .3 high-air temperature; and
- .4 high condensate level at automatic drain of water separator."

\*\*\*



**ANNEX 15**

**RESOLUTION MSC.361(92)  
(Adopted on 21 June 2013)**

**OPERATION OF THE INTERNATIONAL LRIT DATA EXCHANGE AFTER 2013**

THE MARITIME SAFETY COMMITTEE,

RECALLING Article 28(b) of the Convention on the International Maritime Organization concerning the functions of the Committee,

RECALLING ALSO the provisions of regulation V/19-1 (Long-range identification and tracking (LRIT) of ships) of the International Convention for the Safety of Life at Sea (SOLAS), 1974, as amended (the Convention), and, in particular, paragraph 10.1 of the *Revised performance standards and functional requirements for the long-range identification and tracking (LRIT) of ships*, adopted by resolution MSC.263(84), as amended by resolution MSC.330(90),

FURTHER RECALLING that, at its eighty-ninth session, it adopted resolution MSC.322(89) on Operation of the International LRIT Data Exchange (IDE) with respect to the operation of the IDE until 31 December 2013,

BEARING IN MIND that, at its ninetieth session, it agreed with a proposal for the continuation of the hosting, maintenance and operation of the IDE by the European Maritime Safety Agency (EMSA) and of its disaster recovery site by the United States beyond 2013,

HAVING CONSIDERED, at its ninety-second session, the need to put in place all the necessary arrangements so as to ensure the continuous operation of the IDE after 31 December 2013,

1. EXPRESSES its appreciation to Austria, Belgium, Bulgaria, Cyprus, the Czech Republic, Denmark, Estonia, Finland, France, Germany, Greece, Hungary, Ireland, Italy, Latvia, Lithuania, Luxembourg, Malta, the Netherlands, Poland, Portugal, Romania, Slovakia, Slovenia, Spain, Sweden, the United Kingdom and the European Commission for their generous offers to continue hosting, maintaining and operating the IDE by EMSA beyond 2013, at no cost to either the Contracting Governments to the Convention or the Organization;
2. EXPRESSES ALSO its appreciation to the United States for their generous offers to continue hosting, maintaining and operating the disaster recovery site of the IDE beyond 2013, at no cost to either the Contracting Governments to the Convention or the Organization;
3. AGREES that EMSA should continue hosting, maintaining and operating the IDE at EMSA premises in Lisbon, Portugal, beyond 2013, until advised otherwise;
4. AGREES ALSO that the United States should continue hosting, maintaining and operating the disaster recovery site of the IDE at the United States Coast Guard Operations System Center (OSC), subject to their national procurement regulations, beyond 2013, until advised otherwise.

\*\*\*





## ANNEX 16

### DRAFT AMENDMENTS TO THE INTERNATIONAL CODE FOR THE CONSTRUCTION AND EQUIPMENT OF SHIPS CARRYING DANGEROUS CHEMICALS IN BULK (IBC CODE)

#### Chapter 1 – General

1 New paragraphs 1.3.37 and 1.3.38 are added as follows:

"1.3.37 Purging means the introduction of inert gas into a tank which is already in an inert condition with the object of further reducing the oxygen content; and/or reducing the existing hydrocarbon or other flammable vapours content to a level below which combustion cannot be supported if air is subsequently introduced into the tank.

1.3.38 Gas-freeing means the process where a portable or fixed ventilation system is used to introduce fresh air into a tank in order to reduce the concentration of hazardous gases or vapours to a level safe for tank entry."

#### Chapter 2 – Ship survival capability and location of cargo tanks

##### 2.2 – Freeboard and intact stability

2 The title of section 2.2 is amended to read:

"Freeboard and stability"

3 A new subparagraph 2.2.6 is added as follows:

"2.2.6 All ships, subject to the Code, shall be fitted with a stability instrument, capable of verifying compliance with intact and damage stability requirements, approved by the Administration having regard to the performance standards recommended by the Organization\*:

- .1 ships constructed before [date of entry into force] shall comply with this requirement at the first scheduled renewal survey of the ship after [date of entry into force] but not later than [five years after date of entry into force];
- .2 notwithstanding the requirements of 2.2.6.1, a stability instrument installed on a tanker constructed before [date of entry into force] need not be replaced provided it is capable of verifying compliance with intact and damage stability, to the satisfaction of the Administration; and
- .3 for the purposes of control under regulation 11 of MARPOL Annex I, the Administration shall issue a document of approval for the stability instrument.

\*

Refer to part B, chapter 4, of the International Code on Intact Stability, 2008 (2008 IS Code), as amended; the *Guidelines for the Approval of Stability Instruments* (MSC.1/Circ.1229), annex, section 4, as amended; and the technical standards defined in part 1 of the *Guidelines for verification of damage stability requirements for tankers* (MSC.1/Circ.1461).

4 A new subparagraph 2.2.7 is added as follows:

"2.2.7 The Administration may give special dispensation to the following ships from the requirements of paragraph 2.2.6 provided the procedures employed for intact and damage stability verification maintain the same degree of safety, as being loaded in accordance with the approved conditions\*. Any such dispensation shall be duly noted on the International Certificate of Fitness referred to in paragraph 1.5.4:

- .1 ships which are on a dedicated service, with a limited number of permutations of loading such that all anticipated conditions have been approved in the stability information provided to the master in accordance with the requirements of paragraph 2.2.5;
- .2 ships where stability verification is made remotely by a means approved by the Administration;
- .3 ships which are loaded within an approved range of loading conditions; or
- .4 ships constructed before [date of entry into force] provided with approved limiting KG/GM curves covering all applicable intact and damage stability requirements.

---

\* Refer to operational guidance provided in part 2 of the *Guidelines for verification of damage stability requirements for tankers* (MSC.1/Circ.1461)."

## **Chapter 8 – Cargo tank venting and gas-freeing arrangements**

5 In paragraph 8.15, the references to "SOLAS regulations II-2/4.5.3 and 4.5.6" are replaced by the references to "SOLAS regulations II-2/4.5.3, 4.5.6 and 16.3.2".

6 A new paragraph 8.5 is inserted as follows:

### **"8.5 Cargo tank purging**

When the application of inert gas is required by 11.1.1, before gas freeing, the cargo tanks shall be purged with inert gas through outlet pipes with cross sectional area such that an exit velocity of at least 20 m/s can be maintained when any three tanks are being simultaneously supplied with inert gas. The outlets shall extend not less than 2 m above the deck level. Purging shall continue until the concentration of hydrocarbon or other flammable vapours in the cargo tanks has been reduced to less than 2 per cent by volume."

7 The existing paragraph 8.5 and subparagraphs 8.5.1, 8.5.2 and 8.5.3 are renumbered as paragraph 8.6 and subparagraphs 8.6.1, 8.6.2 and 8.6.3, respectively.

## **Chapter 9 – Environmental control**

8 The chapeau of paragraph 9.1.3 is replaced by the following:

"9.1.3 Where inerting or padding of cargo tanks is required by this Code in column "h" of chapter 17:"

## Chapter 11 – Fire protection and fire extinction\*

9 Subparagraph 11.1.1.1 is replaced by the following:

"11.1.1.1 Regulations 10.8 and 10.9 shall not apply;"

## Chapter 15 – Special requirements

10 Paragraph 15.13.5 is replaced by the following:

"15.13.5 When a product containing an oxygen dependent inhibitor is to be carried in a ship:

- .1 constructed on or after [date of entry into force of the new SOLAS inert gas requirements], and for which inerting is required as per paragraph 11.1.1 of this Code, the application of inert gas shall not take place before loading or during the voyage, but shall be applied before commencement of unloading\*;
- .2 constructed before [entry into force of the SOLAS amendments for inert gas], the product shall be carried without inertion (in tanks of a size not greater than 3,000 m<sup>3</sup>). Such cargo shall not be carried in a tank requiring inertion under the requirements of SOLAS chapter II-2\*.

\* When new arrangements for the carriage of oxygen-dependent inhibitors are agreed."

## Chapter 17 – Summary of minimum requirements

11 The explanatory notes for "Tank environment control (column h)" are replaced by the following:

"Tank environmental control (column h)	Inert:	inerting (9.1.2.1)
	Pad:	liquid or gas padding (9.1.2.2)
	Dry:	drying (9.1.2.3)
	Vent:	natural or forced ventilation (9.1.2.4)
	No:	no special requirements under this Code (inerting requirements may be required under SOLAS)"

## Certificate of Fitness

12 Paragraph 6 is replaced with the following:

"6 That the ship must be loaded:

- .1\* only in accordance with loading conditions verified compliant with intact and damage stability requirements using the approved stability instrument fitted in accordance with paragraph 2.2.6 of the Code;
- .2\* where a dispensation permitted by paragraph 2.2.7 of the Code applies and the approved stability instrument required by paragraph 2.2.6 of the Code is not fitted, loading shall be made in accordance with the following approved methods:

- (i) in accordance with the loading conditions provided in the approved loading manual, stamped and dated ..... and signed by a responsible officer of the Administration, or of an organization recognized by the Administration; or
- (ii) in accordance with loading conditions verified remotely using an approved means .....; or
- (iii) in accordance with a loading condition which lies within an approved range of conditions defined in the approved loading manual referred to in (i) above; or
- (iv) in accordance with a loading condition verified using approved critical KG/GM data defined in the approved loading manual referred to in (i) above;

.3\* in accordance with the loading limitations appended to this Certificate.

Where it is required to load the ship other than in accordance with the above instruction, then the necessary calculations to justify the proposed loading conditions shall be communicated to the certifying Administration who may authorize in writing the adoption of the proposed loading condition.

---

\* Delete as appropriate."

\*\*\*

**ANNEX 18**

**RESOLUTION MSC.362(92)  
(Adopted on 14 June 2013)**

**REVISED RECOMMENDATION ON A STANDARD METHOD FOR  
EVALUATING CROSS-FLOODING ARRANGEMENTS**

THE MARITIME SAFETY COMMITTEE,

RECALLING Article 28(b) of the Convention on the International Maritime Organization concerning the functions of the Committee,

RECALLING ALSO resolution A.266(VIII), by which the Assembly, at its eighth session, adopted the *Recommendation on a standard method for establishing compliance with the requirements for cross-flooding arrangements in passenger ships*,

RECALLING FURTHER resolution MSC.245(83), by which it, at its eighty-third session, adopted the *Recommendation on a standard method for evaluating cross-flooding arrangements*,

NOTING that the above *Recommendation on a standard method for evaluating cross-flooding arrangements* needed to be revised and improved, based on recent research results regarding cross-flooding,

RECOGNIZING the need to establish a methodology for evaluating cross-flooding arrangements on ships subject to the applicable subdivision and damage stability requirements of SOLAS chapter II-1 to ensure uniform treatment of cross-flooding and equalization arrangements,

HAVING CONSIDERED, at its ninety-second session, the *Revised Recommendation on a standard method for evaluating cross-flooding arrangements*, prepared by the Sub-Committee on Stability and Load Lines and on Fishing Vessels Safety, at its fifty-fifth session,

1. ADOPTS the *Revised Recommendation on a standard method for evaluating cross-flooding arrangements*, the text of which is set out in the annex to the present resolution;
2. INVITES Governments to apply the annexed Revised Recommendation to ships constructed on or after 14 June 2013 and to bring it to the attention of all parties concerned;
3. NOTES that calculations to evaluate cross-flooding arrangements performed before 14 June 2013 remain valid.

\* \* \*

ANNEX

**REVISED RECOMMENDATION ON A STANDARD METHOD FOR  
EVALUATING CROSS-FLOODING ARRANGEMENTS**

Table of contents

1	Definitions
2	Formulae
3	Air pipe venting criteria
4	Alternatives
Appendix 1	Examples for treatment of heel angles and water heads at different stages of cross-flooding
Appendix 2	Friction coefficients in cross-flooding arrangements
Appendix 3	Example using figures for a passenger ship

## 1 Definitions

$\Sigma k$ : Sum of friction coefficients in the considered cross-flooding arrangement.

$s$  ( $m^2$ ): Cross-section area of the cross-flooding pipe or duct. If the cross-section area is not circular, then:

$$s_{equiv} = \frac{\pi \cdot D_{equiv}^2}{4}$$

where:

$$D_{equiv} = \frac{4 \cdot A}{p}$$

A = actual cross-section area

p = actual cross-section perimeter

$\theta_0$  ( $^\circ$ ): Angle before commencement of cross-flooding. The cross-flooding device may be assumed to be full or empty dependent on its arrangement and internal volume (see figure 1(b) in appendix 1).

$\theta_f$  ( $^\circ$ ): Heel angle at final equilibrium ( $\theta_f \leq \theta$ ).

$\theta$  ( $^\circ$ ): Any angle of heel between the commencement of cross-flooding and the final equilibrium at a given time.

$W_f$  ( $m^3$ ): Volume of water which is used to bring the ship from commencement of cross-flooding  $\theta_0$  to final equilibrium  $\theta_f$ .

$W_\theta$  ( $m^3$ ): Volume of water which is used to bring the ship from any angle of heel  $\theta$  to the final equilibrium  $\theta_f$ .

$H_0$  (m): Head of water before commencement of cross-flooding, with the same assumption as for  $\theta_0$ .

$H_\theta$  (m): Head of water when any angle of heel  $\theta$  is achieved.

$h_f$  (m): Final head of water after cross-flooding ( $h_f = 0$ , when the level inside the equalizing compartment is equal to the free level of the sea).

$g$  ( $m/s^2$ ): The acceleration due to gravity ( $9.81 m/s^2$ ).

## 2 Formulae

2.1 Time required from commencement of cross-flooding  $\theta_0$  to the final equilibrium  $\theta_f$ :

$$T_f = \frac{2W_f}{S \cdot F} \cdot \frac{1}{\sqrt{2gH_0}} \cdot \frac{1}{\left(1 + \sqrt{\frac{h_f}{H_0}}\right)}$$

2.2 Time required to bring the ship from any angle of heel  $\theta$  to the final equilibrium  $\theta_f$ :

$$T_\theta = \frac{2W_\theta}{S \cdot F} \cdot \frac{1}{\sqrt{2gH_\theta}} \cdot \frac{1}{\left(1 + \sqrt{\frac{h_f}{H_\theta}}\right)}$$

2.3 Time required from commencement of cross-flooding  $\theta_0$  until any angle of heel  $\theta$  is achieved:

$$T = T_f - T_\theta$$

2.4 Dimensionless factor of reduction of speed through an equalization device, being a function of bends, valves, etc. in the cross-flooding system:

$$F = \frac{1}{\sqrt{(\sum k_i) + 1}}$$

Values for k can be obtained from appendix 2 or other appropriate sources such as computational fluid dynamics (CFD) or model testing. If other appropriate sources are used, then the +1 factor in the formulae may not be appropriate. CFD can also be used to evaluate the discharge coefficient for the whole cross-flooding duct.

2.5 Cross-flooding through successive devices of different cross-section:

If the same flow crosses successive flooding devices of cross-section  $S_1, S_2, S_3...$  having corresponding friction coefficients  $k_1, k_2, k_3...$ , then the total k coefficient referred to  $S_1$  is:

$$\sum k = k_1 + k_2 \cdot S_1^2/S_2^2 + k_3 \cdot S_1^2/S_3^2...$$

2.6 If different flooding devices are not crossed by the same volume, each k coefficient should be multiplied by the square of the ratio of the volume crossing the device and the volume crossing the reference section (which will be used for the time calculation):

$$\sum k = k_1 + k_2 \cdot S_1^2/S_2^2 \cdot W_2^2/W_1^2 + k_3 \cdot S_1^2/S_3^2 \cdot W_3^2/W_1^2...$$

2.7 For cross-flooding through devices in parallel that lead to the same space, equalization time should be calculated assuming that:

$$S \cdot F = S_1 \cdot F_1 + S_2 \cdot F_2 + ...$$

With  $F = \frac{1}{\sqrt{(\sum k_i) + 1}}$  for each device of cross-section  $S_i$



### 3 Air pipe venting criteria

3.1 In arrangements where the total air pipe sectional area is 10 per cent or more of the cross-flooding sectional area, the restrictive effect of any air back pressure may be neglected in the cross-flooding calculations. The air pipe sectional area should be taken as the minimum or the net sectional area of any automatic closing devices, if that is less.

3.2 In arrangements where the total air pipe sectional area is less than 10 per cent of the cross-flooding sectional area, the restrictive effect of air back pressure should be considered in the cross-flooding calculations. The following method may be used for this purpose:

The  $k$  coefficient used in the calculation of cross-flooding time should take into account the drop of head in the air pipe. This can be done using an equivalent coefficient  $k_e$ , which is calculated according to the following formula:

$$k_e = k_w + k_a \cdot (\rho_a / \rho_w) \cdot (S_w / S_a)^2$$

where:

$k_w$  =  $k$  coefficient for the cross-flooding arrangement (water)

$k_a$  =  $k$  coefficient for the air pipe

$\rho_a$  = air density

$\rho_w$  = water density

$S_w$  = cross-section area of the cross-flooding device (water)

$S_a$  = cross-section of air pipe

### 4 Alternatives

As an alternative to the provisions in sections 2 and 3, and for arrangements other than those shown in appendix 2, direct calculation using computational fluid dynamics (CFD), time-domain simulations or model testing may also be used.

\* \* \*

Appendix 1

EXAMPLES FOR TREATMENT OF HEEL ANGLES AND WATER HEADS  
AT DIFFERENT STAGES OF CROSS-FLOODING

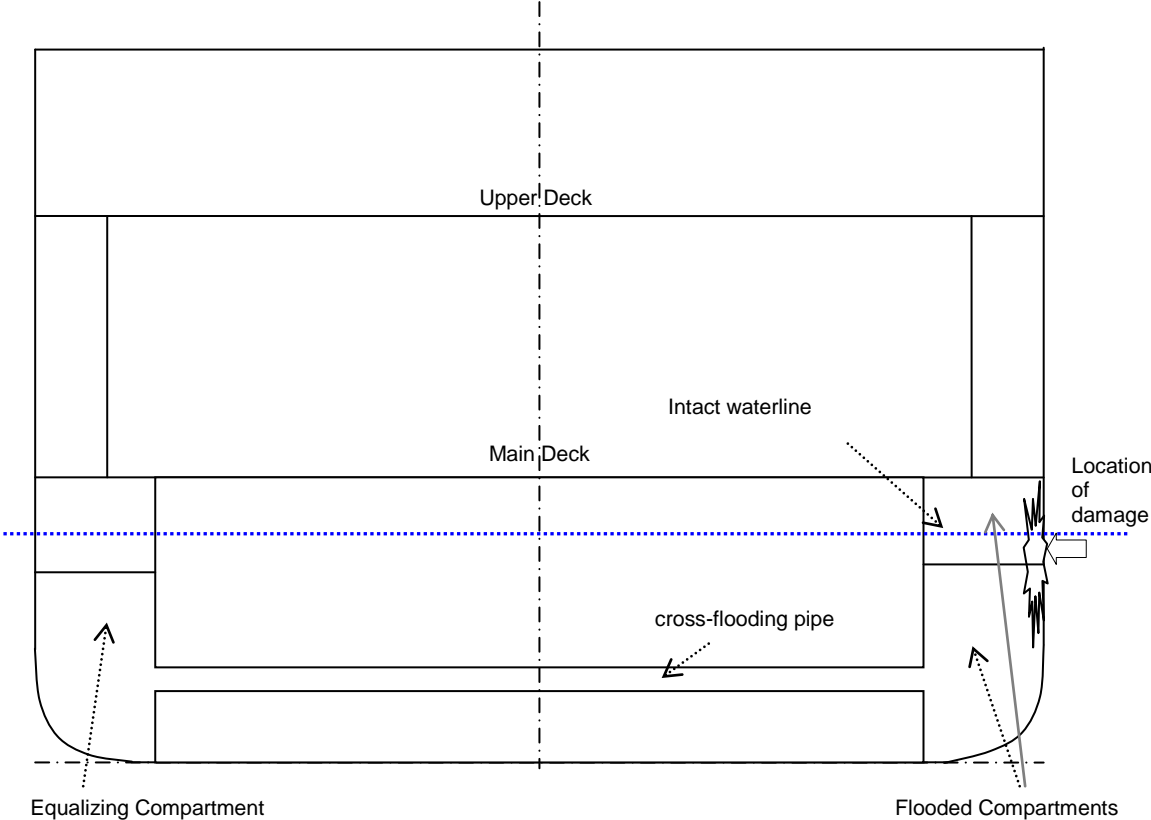
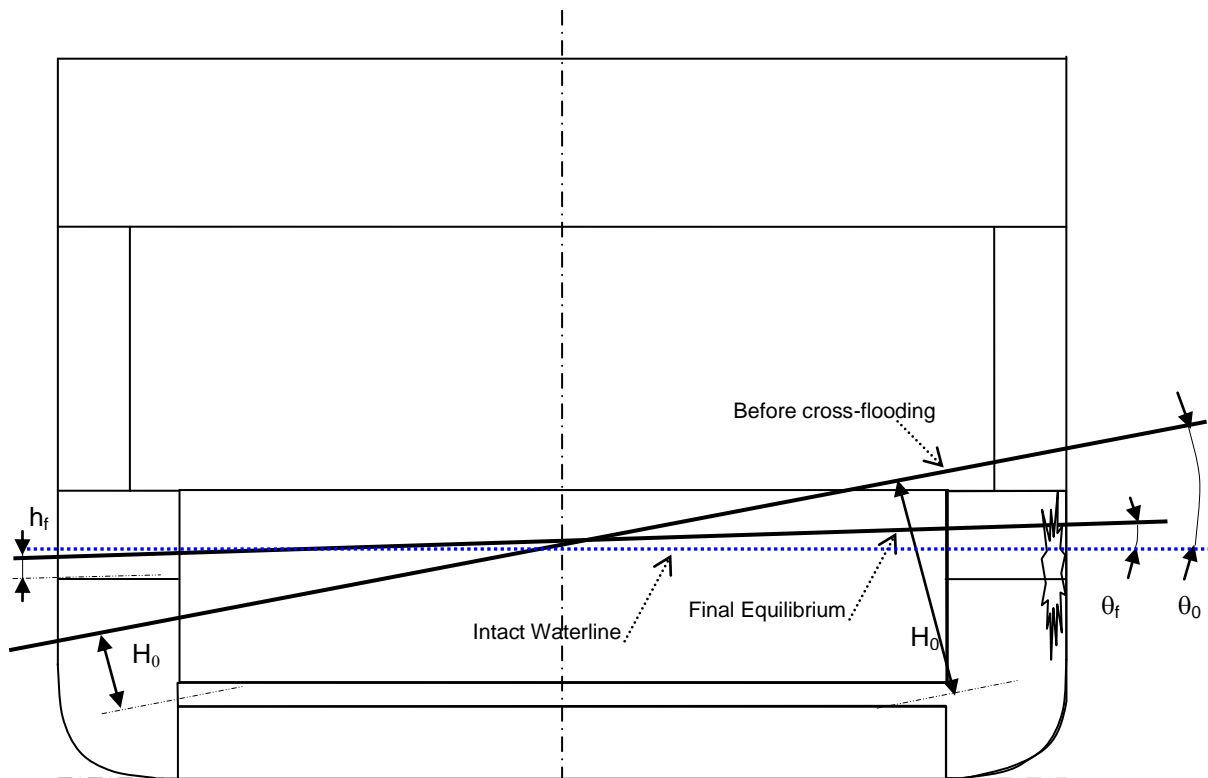
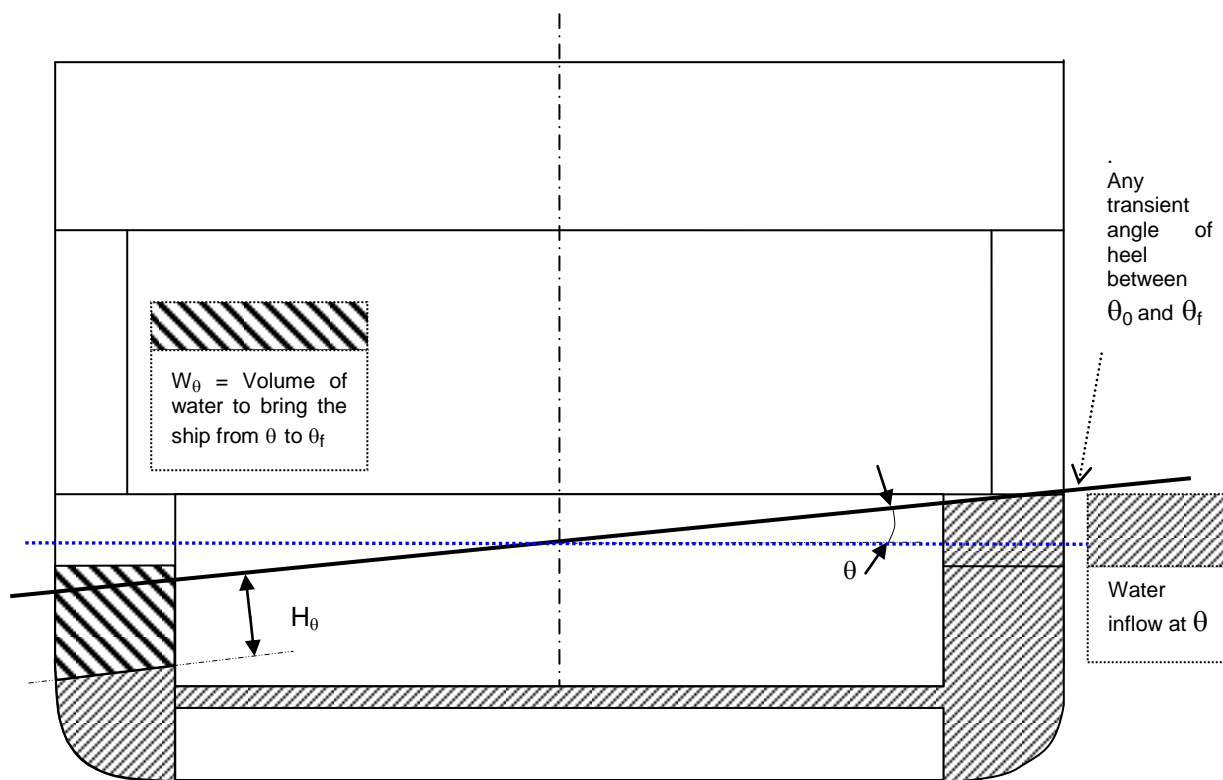

Figure 1(a) – Section showing cross-flooding pipe and compartments



**Figure 1(b) – Initial and Final stages of cross-flooding**

*Note:  $H_0$  on the left side of figure 1(b) depicts the head of water if the cross-flooding device was assumed full whereas  $H_0$  on the right side of figure 1(b) shows the head of water if the cross-flooding device was assumed empty.*



**Figure 1(c) – Situation at any transient angle of heel,  $\theta$**

\*\*\*

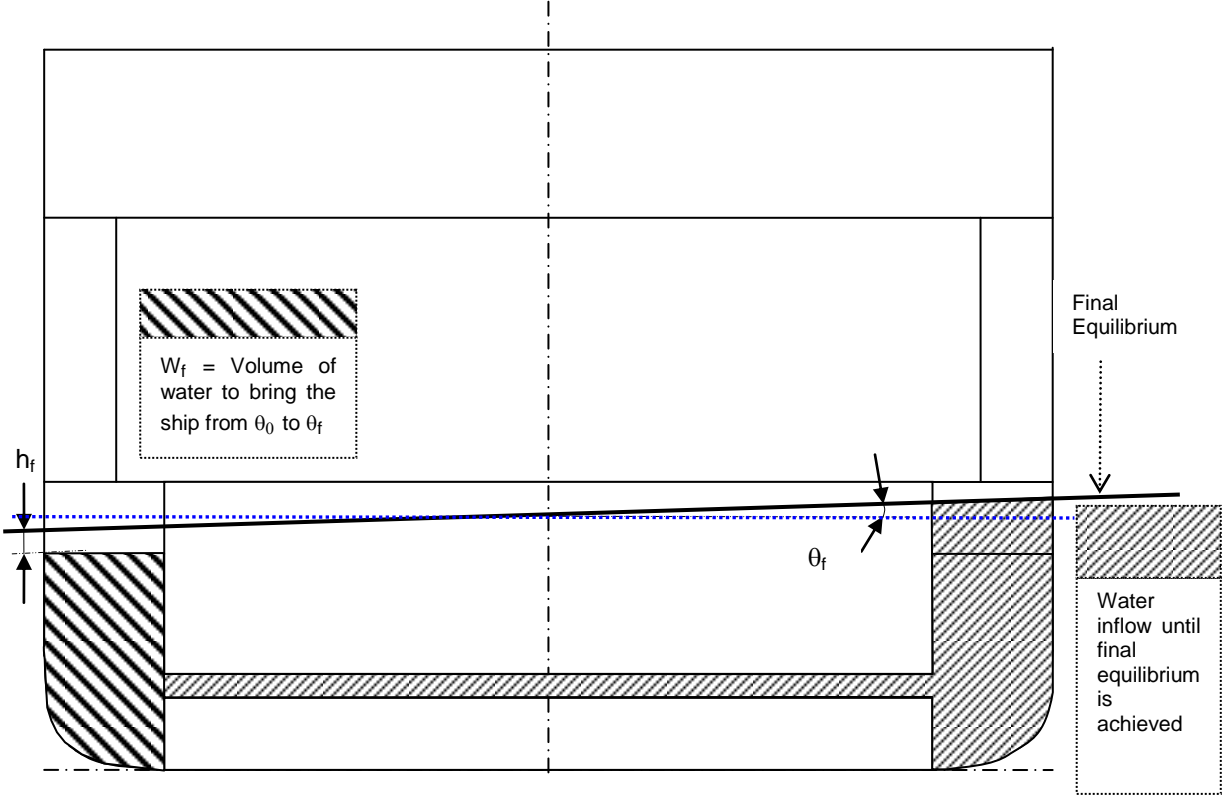
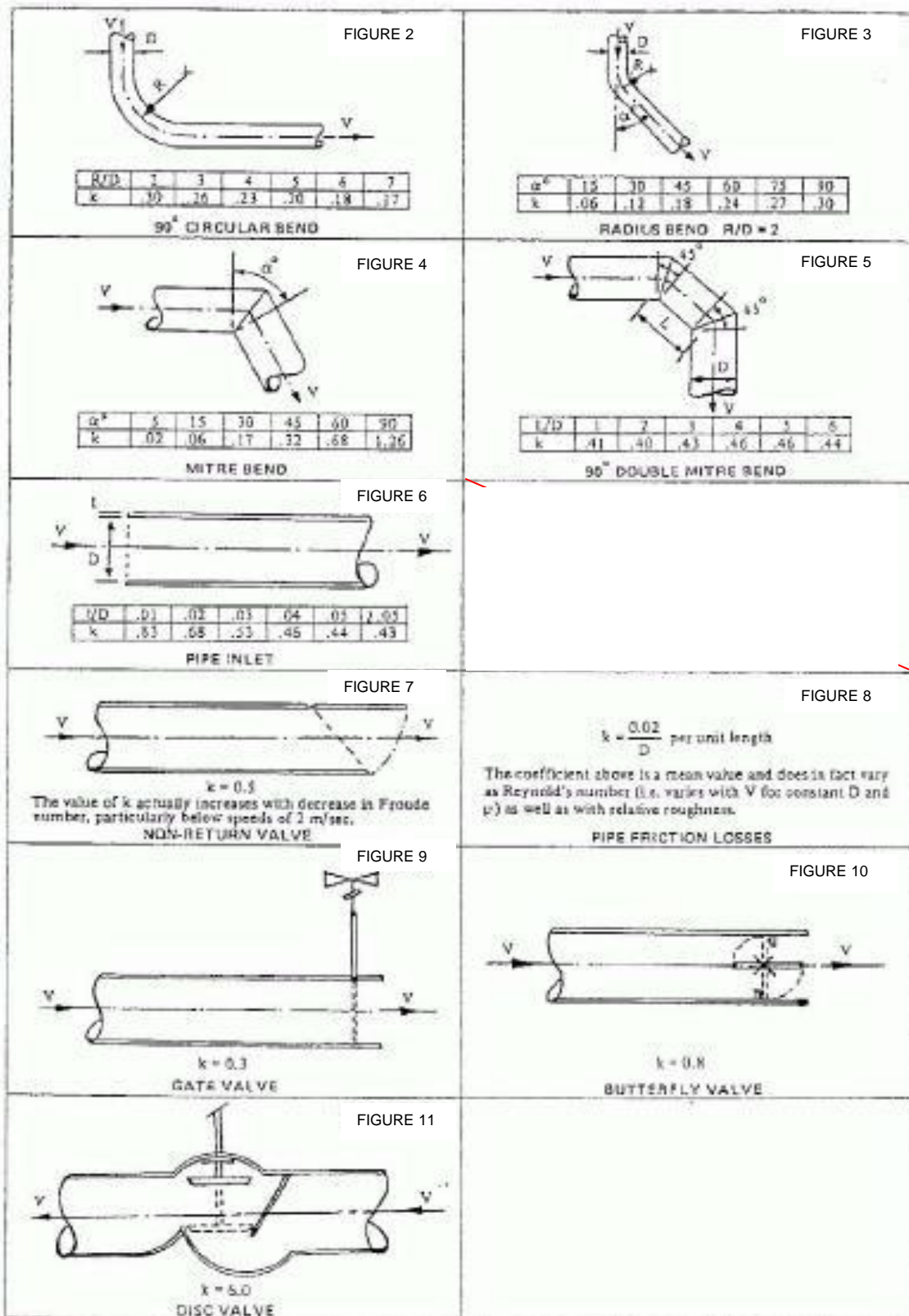

Figure 1(d) – Situation at final equilibrium

\* \* \*

Appendix 2

FRICITION COEFFICIENTS IN CROSS-FLOODING ARRANGEMENTS



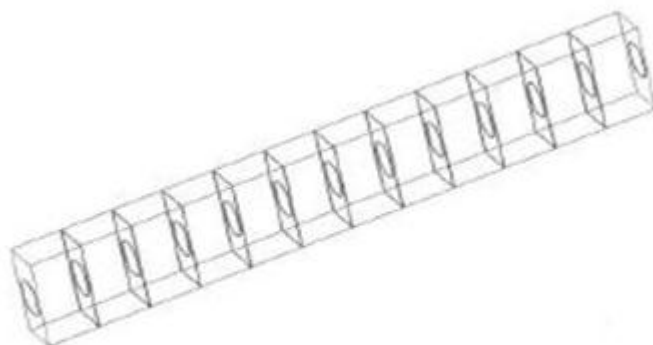

**Figure 11**  
**Cross-flooding through a series of structural ducts with 1 manhole**

$$k = 0.6718 \times L_i^{0.119} \quad (0 < L_i < 12)$$
$$k = 0.903 \quad (12 \leq L_i)$$

where:

- k        friction coefficient related to each space between two adjacent girders
- $L_i$      Length of the duct in meters

Note:  $k$  is evaluated with effective cross-section area therefore in calculations use the real cross-section area  $A$  and not  $S_{equiv}$ . The pressure loss for entrance in the first manhole is already computed in the calculation.

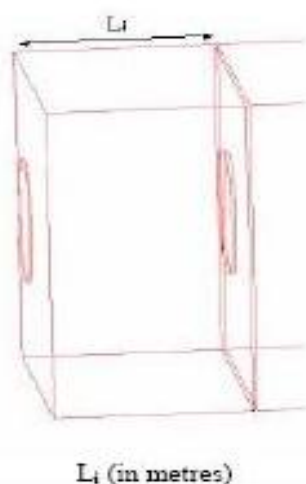

**Figure 12**

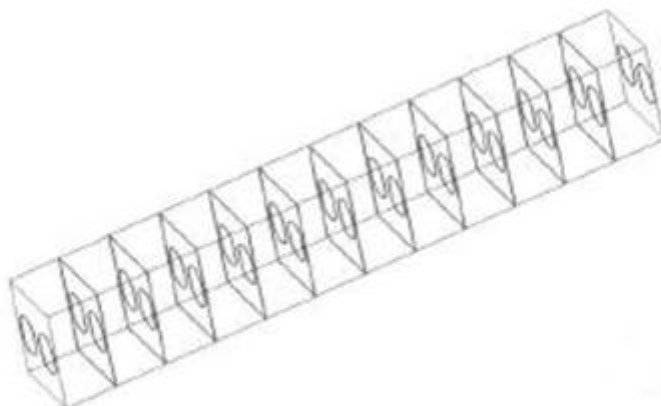

**Figure 13**  
**Cross-flooding through a series of structural ducts with 2 manholes**

$$k = 1.7968 \times L_i^{-0.026} \quad (0 < L_i < 12)$$

$$k = 1.684 \quad (12 \leq L_i)$$

where:

- |       |   |
|-------|---|
| k     | friction coefficient related to each space between two adjacent girders |
| $L_i$ | Length of the duct in meters  |

Note:  $k$  is evaluated with effective cross-section area therefore in calculations use the real cross-section area  $A$  and not  $S_{equiv}$ . The pressure loss for entrance in the first manhole is already computed in the calculation.

\* \* \*

### Appendix 3

#### EXAMPLE USING FIGURES FOR A PASSENGER SHIP

*Dimension of the considered cross-flooding pipe:*

Diameter	D = 0.39 m
Length	l = 21.0 m
Cross-section area	S = 0.12 m <sup>2</sup>
Wall thickness	t = 17.5 mm

*k-values for the considered cross-flooding system:*

Inlet	0.45
Pipe friction ( $\frac{0.02l}{D}$ )	1.08
2 radius bends ( $\alpha = 45^\circ$ )	0.36
Non-return valve	0.50

Sufficient air venting is assumed to be in place.

From this follows:

$$F = \frac{1}{\sqrt{(\sum k_i) + 1}} \qquad F = \frac{1}{\sqrt{3.39}} = 0.54$$

Time required from commencement of cross-flooding  $\theta_0$  to the final equilibrium condition  $\theta_f$ :

$$T_f = \frac{2W_f}{S \cdot F} \cdot \frac{1}{\sqrt{2gH_0}} \left( \frac{1}{1 + \sqrt{\frac{h_f}{H_0}}} \right)$$

Head of water before commencement of cross-flooding:

$$H_0 = 5.3m$$

Volume of water which is used to bring the ship from commencement of cross-flooding to the final equilibrium condition:

$$W_f = 365m^3$$



Final head of water after cross-flooding:

$$h_f = 1.5m$$

$$T_f = \frac{2 \cdot 365m^3}{0.12m^2 \cdot 0.54} \cdot \frac{1}{\sqrt{2 \cdot 9.81m/s^2 \cdot 5.3m}} \cdot \frac{1}{\left(1 + \sqrt{\frac{1.5m}{5.3m}}\right)}$$

$$T_f = 721s$$

Calculation of any transient situation of cross-flooding:

The purpose is to find the situation after 600s.

Assumed transient situation:

Cross-flooded volume: 265 m<sup>3</sup>

Volume of water which is used to bring the vessel from the transient situation to the final equilibrium :  $W_\theta = 365 m^3 - 265 m^3 = 100 m^3$

Corresponding head of water:  $H_\theta = 2.8 m$

Time required to bring the vessel from any transient situation to the final equilibrium condition:

$$T_\theta = \frac{2W_\theta}{S \cdot F} \cdot \frac{1}{\sqrt{2gH_\theta}} \cdot \frac{1}{\left(1 + \sqrt{\frac{h_f}{H_\theta}}\right)}$$

$$T_\theta = \frac{2 \cdot 100m^3}{0.12m^2 \cdot 0.54} \cdot \frac{1}{\sqrt{2 \cdot 9.81m/s^2 \cdot 2.8m}} \cdot \frac{1}{\left(1 + \sqrt{\frac{1.5 \approx m}{2.8 \approx m}}\right)}$$

$$T_\theta = 240 s$$

Time between commencement of cross-flooding and assumed transient situation:

$$T = T_f - T_\theta = 721 s - 240 s = 481 s$$

As T is less than 600 s, further transient situations with larger cross-flooded volume may be calculated in the same way.

On the reverse, if T was of more than 600 s, further transient situation with smaller cross-flooded volume may be calculated.

Situation after 600 s may be found by successive iterations.

\*\*\*



## ANNEX 19

### DRAFT AMENDMENTS TO THE CODE FOR THE CONSTRUCTION AND EQUIPMENT OF SHIPS CARRYING DANGEROUS CHEMICALS IN BULK (BCH CODE)

#### CHAPTER II CARGO CONTAINMENT

##### Part A – Physical protection (Siting of cargo tanks: ship stability)

1 The existing subparagraph 2.2.1 is replaced by the following:

"2.2.1 General: Ships subject to this Code may be assigned the minimum freeboard permitted by the International Convention on Load Lines, 1966. The additional requirements in paragraph 2.2.4, taking into account any empty or partially filled tank as well as the specific gravities of cargoes to be carried, however, should govern the allowed operating draught for any actual condition of loading.

2.2.1.1 All ships engaged in the transport of chemicals in bulk should be supplied with loading and stability manuals for the information and guidance of the master. These manuals should contain details concerning the loaded conditions of full and empty or partially empty tanks, the position of these tanks in the ship, the specific gravities of the various parcels of cargoes carried, and any ballast arrangements in critical conditions of loading. Provisions for evaluating other conditions of loading should be contained in the manuals.

2.2.1.2 All ships, subject to the Code, shall be fitted with a stability instrument, capable of verifying compliance with intact and damage stability requirements, approved by the Administration, having regard to the performance standards recommended by the Organization\*:

- .1 ships constructed before [date of entry into force] shall comply with this paragraph at the first scheduled renewal survey of the ship after [date of entry into force] but not later than [five years after date of entry into force];
- .2 notwithstanding the requirements of 2.2.1.2.1, a stability instrument installed on a ship constructed before [date of entry into force] need not be replaced provided it is capable of verifying compliance with intact and damage stability, to the satisfaction of the Administration; and
- .3 for the purposes of control under regulation 11 of MARPOL Annex I, the Administration shall issue a document of approval for the stability instrument.

---

\* Refer to part B, chapter 4, of the International Code on Intact Stability, 2008 (2008 IS Code), as amended; *the Guidelines for the Approval of Stability Instruments* (MSC.1/Circ.1229), annex, section 4, as amended; and the technical standards defined in part 1 of the *Guidelines for verification of damage stability requirements for tankers* (MSC.1/Circ.1461).

2.2.1.3 The Administration may give special dispensation to the following ships from the requirements of paragraph 2.2.1.2 provided the procedures employed for intact and damage stability verification maintain the same degree of safety as being loaded in accordance with the approved conditions\*\*. Any such dispensation shall be duly noted on the Certificate of Fitness referred to in paragraph 1.6.3:

- .1 ships which are on a dedicated service, with a limited number of permutations of loading such that all anticipated conditions have been approved in the stability information provided to the master in accordance with the requirements of paragraph 2.2.1.1;
- .2 ships where stability verification is made remotely by a means approved by the Administration;
- .3 ships which are loaded within an approved range of loading conditions;  
or
- .4 ships provided with approved limiting KG/GM curves covering all applicable intact and damage stability requirements.

\*\* Refer to operational guidance provided in part 2 of the *Guidelines for verification of damage stability requirements for tankers* (MSC.1/Circ.1461)."

### Certificate of Fitness

2 The existing paragraph 6 is replaced by the following:

"6 That the ship must be loaded:

- .1<sup>\*</sup> only in accordance with loading conditions verified compliant with intact and damage stability requirements using the approved stability instrument fitted in accordance with paragraph 2.2.1.2 of the Code;
- .2<sup>\*</sup> where a dispensation permitted by paragraph 2.2.1.3 of the Code applies and the approved stability instrument required by paragraph 2.2.1.2 of the Code is not fitted, loading shall be made in accordance with the following approved methods:
  - .i in accordance with the loading conditions provided in the approved loading manual, stamped and dated ..... and signed by a responsible officer of the Administration, or of an organization recognized by the Administration; or
  - .ii in accordance with loading conditions verified remotely using an approved means .....; or
  - .iii in accordance with a loading condition which lies within an approved range of conditions defined in the approved loading manual referred to in i above; or
  - .iv in accordance with a loading condition verified using approved critical KG/GM data defined in the approved loading manual referred to in i above;
- .3<sup>\*</sup> in accordance with the loading limitations appended to this Certificate.

Where it is required to load the ship other than in accordance with the above instruction, then the necessary calculations to justify the proposed loading conditions shall be communicated to the certifying Administration who may authorize in writing the adoption of the proposed loading condition.

\* Delete as appropriate."

\*\*\*

## ANNEX 20

### DRAFT AMENDMENTS TO THE CODE FOR EXISTING SHIPS CARRYING LIQUEFIED GASES IN BULK (EGC CODE)

#### Chapter II – Freeboard and stability

1 A new paragraph 2.3 is added as follows:

"2.3 All ships, subject to the Code shall be fitted with a stability instrument, capable of verifying compliance with intact and damage stability requirements, approved by the Administration having regard to the performance standards recommended by the Organization\*:

- .1 ships constructed before [date of entry into force] shall comply with this paragraph at the first scheduled renewal survey of the ship after [date of entry into force] but not later than [five years after date of entry into force];
- .2 notwithstanding the requirements of 2.3.1, a stability instrument installed on a ship constructed before [date of entry into force] need not be replaced provided it is capable of verifying compliance with intact and damage stability, to the satisfaction of the Administration; and
- .3 for the purposes of control under regulation 11 of MARPOL Annex I, the Administration shall issue a document of approval for the stability instrument.

---

\* Refer to part B, chapter 4, of the International Code on Intact Stability, 2008 (2008 IS Code), as amended; the *Guidelines for the Approval of Stability Instruments* (MSC.1/Circ.1229), annex, section 4, as amended; and the technical standards defined in part 1 of the *Guidelines for verification of damage stability requirements for tankers* (MSC.1/Circ.1461)."

2 A new paragraph 2.4 is added as follows:

"2.4 The Administration may give special dispensation to the following ships from the requirements of paragraph 2.3, provided the procedures employed for intact and damage stability verification maintain the same degree of safety as being loaded in accordance with the approved conditions\*. Any such dispensation shall be duly noted on the Certificate of Fitness referred to in paragraph 1.6.1:

- .1 ships which are on a dedicated service, with a limited number of permutations of loading such that all anticipated conditions have been approved in the stability information provided to the master in accordance with the requirements of paragraph 2.2;
- .2 ships where stability verification is made remotely by a means approved by the Administration;
- .3 ships which are loaded within an approved range of loading conditions; or

- .4 ships provided with approved limiting KG/GM curves covering all applicable intact and damage stability requirements.

\* Refer to operational guidance provided in part 2 of the *Guidelines for verification of damage stability requirements for tankers* (MSC.1/Circ.1461)."

### Certificate of Fitness

3 A new paragraph 6 is added as follows:

"6 That the ship must be loaded:

- .1\* only in accordance with loading conditions verified compliant with intact and damage stability requirements using the approved stability instrument fitted in accordance with paragraph 2.3 of the Code;
- .2\* where a dispensation permitted by paragraph 2.4 of the Code applies and the approved stability instrument required by paragraph 2.3 of the Code is not fitted, loading shall be made in accordance with the following approved methods:
  - .i in accordance with the loading conditions provided in the approved loading manual, stamped and dated ..... and signed by a responsible officer of the Administration, or of an organization recognized by the Administration; or
  - .ii in accordance with loading conditions verified remotely using an approved means.....; or
  - .iii in accordance with a loading condition which lies within an approved range of conditions defined in the approved loading manual referred to in i above; or
  - .iv in accordance with a loading condition verified using approved critical KG/GM data defined in the approved loading manual referred to in i above;
- .3\* in accordance with the loading limitations appended to this Certificate.

Where it is required to load the ship other than in accordance with the above instruction, then the necessary calculations to justify the proposed loading conditions shall be communicated to the certifying Administration who may authorize in writing the adoption of the proposed loading condition.

\* Delete as appropriate."

\*\*\*

## ANNEX 21

### DRAFT AMENDMENTS TO THE CODE FOR THE CONSTRUCTION AND EQUIPMENT OF SHIPS CARRYING LIQUEFIED GASES IN BULK (GC CODE)

#### CHAPTER II SHIP SURVIVAL CAPABILITY AND CARGO TANK LOCATION

##### Paragraph 2.2 – Freeboard and stability

1 A new subparagraph 2.2.4 is added as follows:

"2.2.4 All ships, subject to the Code, shall be fitted with a stability instrument, capable of verifying compliance with intact and damage stability requirements, approved by the Administration having regard to the performance standards recommended by the Organization\*:

- .1 ships constructed before [date of entry into force] shall comply with this requirement at the first scheduled renewal survey of the ship after [date of entry into force] but not later than [five years after date of entry into force];
- .2 notwithstanding the requirements of 2.2.4.1, a stability instrument installed on a ship constructed before [date of entry into force] need not be replaced provided it is capable of verifying compliance with intact and damage stability, to the satisfaction of the Administration; and
- .3 for the purposes of control under regulation 11 of MARPOL Annex I, the Administration shall issue a document of approval for the stability instrument.

---

\* Refer to part B, chapter 4, of the International Code on Intact Stability, 2008 (2008 IS Code), as amended; the Guidelines for the Approval of Stability Instruments (MSC.1/Circ.1229), annex, section 4, as amended; and the technical standards defined in part 1 of the *Guidelines for verification of damage stability requirements for tankers* (MSC.1/Circ.1461)."

2 A new subparagraph 2.2.5 is added as follows:

"2.2.5 The Administration may give special dispensation to the following ships from the requirements of paragraph 2.2.4 provided the procedures employed for intact and damage stability verification maintain the same degree of safety as being loaded in accordance with the approved conditions\*. Any such dispensation shall be duly noted on the Certificate of Fitness referred to in paragraph 1.6.4:

- .1 ships which are on a dedicated service, with a limited number of permutations of loading such that all anticipated conditions have been approved in the stability information provided to the master in accordance with the requirements of paragraph 2.2.3;
- .2 ships where stability verification is made remotely by a means approved by the Administration;

- .3 ships which are loaded within an approved range of loading conditions; or
- .4 ships provided with approved limiting KG/GM curves covering all applicable intact and damage stability requirements.

---

\* Refer to operational guidance provided in part 2 of the *Guidelines for verification of damage stability requirements for tankers* (MSC.1/Circ.1461)."

### Certificate of Fitness

3 The existing paragraph 6 is replaced by the following:

"6 That the ship must be loaded:

- .1\* only in accordance with loading conditions verified compliant with intact and damage stability requirements using the approved stability instrument fitted in accordance with paragraph 2.2.4 of the Code;
- .2\* where a dispensation permitted by paragraph 2.2.5 of the Code applies and the approved stability instrument required by paragraph 2.2.4 of the Code is not fitted, loading shall be made in accordance with the following approved methods:
  - .i in accordance with the loading conditions provided in the approved loading manual, stamped and dated ..... and signed by a responsible officer of the Administration, or of an organization recognized by the Administration; or
  - .ii in accordance with loading conditions verified remotely using an approved means.....; or
  - .iii in accordance with a loading condition which lies within an approved range of conditions defined in the approved loading manual referred to in i above; or
  - .iv in accordance with a loading condition verified using approved critical KG/GM data defined in the approved loading manual referred to in i above;
- .3\* in accordance with the loading limitations appended to this Certificate.

Where it is required to load the ship other than in accordance with the above instruction, then the necessary calculations to justify the proposed loading conditions shall be communicated to the certifying Administration who may authorize in writing the adoption of the proposed loading condition.

---

\* Delete as appropriate."

\*\*\*



## ANNEX 22

### DRAFT ASSEMBLY RESOLUTION

#### USE OF NATIONAL TONNAGE IN APPLYING INTERNATIONAL CONVENTIONS

THE ASSEMBLY,

RECALLING Article 15(j) of the Convention on the International Maritime Organization concerning the functions of the Assembly in relation to regulations and guidelines concerning maritime safety and the prevention and control of marine pollution from ships,

RECALLING ALSO that the International Convention on Tonnage Measurement of Ships, 1969 (1969 Tonnage Convention) introduced a new measurement system and that the tonnages measured under this system could be different from those measured under national tonnage rules,

RECALLING FURTHER that recommendation 2 of the International Conference on Tonnage Measurement of Ships, 1969, recommended the acceptance of the tonnages measured under this new system as the parameters referred to where those terms are used in conventions, laws, and regulations, while recognizing that transition to this new system should cause the least possible impact on the economics of merchant shipping and port operations,

NOTING that article 3(2)(d) of the 1969 Tonnage Convention provides for certain ships to retain their national tonnages for the purpose of applying relevant requirements under other existing international conventions, if they do not undergo alterations or modifications which the Administration deems to be a substantial variation in their existing gross tonnage,

NOTING ALSO that the Interim Schemes for Tonnage Measurement of resolutions A.494(XII), A.540(13) and A.541(13) effectively extended this use of national tonnages to certain other ships, for the purpose of applying relevant requirements, respectively, of the International Convention for the Safety of Life at Sea (SOLAS), 1974, as amended, the International Convention on Training, Certification and Watchkeeping for Seafarers (STCW), 1978, and the International Convention for the Prevention of Pollution from Ships, 1973, as modified by the Protocol of 1978 relating thereto (MARPOL),

NOTING FURTHER that resolutions A.758(18) *Application of recommendation 2 of the International Conference on Tonnage Measurement of Ships, 1969* and A.791(19) *Application of the International Convention on Tonnage Measurement of Ships, 1969, to existing ships* were adopted to address identification of national tonnages on International Tonnage Certificates (1969) and other pertinent certificates, including Ship Safety Certificates and International Oil Pollution Prevention Certificates,

BEING AWARE that amendments to the SOLAS, STCW and MARPOL Conventions made subsequent to the adoption of resolutions A.494(XII), A.540(13) and A.541(13) have led to misunderstandings over the use of national tonnage when applying newly established tonnage-based requirements for ships measured in accordance with the provisions of the 1969 Tonnage Convention and the Interim Schemes for Tonnage Measurement, highlighting the need for updated recommendations on this matter,

BEARING IN MIND the decisions of the Maritime Safety Committee to apply newly established tonnage-based requirements of the International Ship and Port Facility and Security (ISPS) and International Safety Management (ISM) Codes using a ship's tonnage as measured under the rules of the 1969 Tonnage Convention,

RECOGNIZING the necessity of uniform implementation of the 1969 Tonnage Convention with regard to national tonnages,

HAVING CONSIDERED the recommendations made by the Maritime Safety Committee, at its ninety-second session (12 to 21 June 2013), and the Marine Environment Protection Committee, at its sixty-fifth session (13 to 17 May 2013),

1. ADOPTS the Recommendation on the use of national tonnage in applying international conventions, as set out in the annex to the present resolution;
2. AGREES that Governments which are Contracting Governments to the 1969 Tonnage Convention should use this Recommendation when applying the provisions of the 1969 Tonnage Convention and Interim Schemes for Tonnage Measurement;
3. REVOKES resolutions A.758(18) and A.791(19).

\* \* \*

ANNEX

**RECOMMENDATION ON THE USE OF NATIONAL TONNAGE  
IN APPLYING INTERNATIONAL CONVENTIONS**

1 In order to ensure consistency when using national tonnage to apply relevant requirements under international conventions, in accordance with article 3(2)(d) of the International Convention on Tonnage Measurement of Ships, 1969 (1969 Tonnage Convention) (TM 69) and Interim Schemes for Tonnage Measurement, as set forth in the *Revised Interim Scheme for tonnage measurement for certain ships* (resolution A.494(XII) for SOLAS), and the *Interim Scheme for tonnage measurement for certain ships for the purposes of the International Convention for the Prevention of Pollution from Ships, 1973, as modified by the Protocol of 1978 relating thereto* (resolution A.541(13)), Administrations are recommended to accept the following.

**National tonnage versus convention tonnage**

2 National tonnage refers to the tonnage measurement of a ship under the Administration's national tonnage rules that predated the adoption of the measurement rules of the 1969 Tonnage Convention. National gross tonnage is often expressed in terms of gross register tons (GRT). In contrast, the unitless gross tonnage measurement under the rules of the 1969 Tonnage Convention is expressed in terms of gross tonnage (GT).

**Eligibility to use national tonnage**

3 The 1969 Tonnage Convention and the Interim Schemes for Tonnage Measurement provide for the use of national tonnage in applying relevant requirements under international conventions to certain ships with keel laid dates on or before 18 July 1994<sup>1</sup>. Further, a ship which undergoes an alteration or modification which the Administration deems to be a substantial variation in its "existing" tonnage as described in article 3(2)(b) of the 1969 Tonnage Convention is treated as if the date on which the alterations or modifications commenced was the keel laid date for this purpose. The following table lists the basis for use of national tonnages as a function of a ship's keel laid/substantial alteration date and its national gross tonnage.

<b>Basis for Using National Tonnage to Apply International Conventions*</b>			
<b>Ship's Keel Laid Date / Substantial Alteration Date</b>	<b>Ship's National Gross Tonnage</b>		
	<b>GRT &lt; 400</b>	<b>400 ≤ GRT &lt; 1600</b>	<b>GRT ≥ 1600</b>
Before 18 July 1982	TM69 Art.3(2)(d)	TM69 Art.3(2)(d)	TM69 Art.3(2)(d)
18 July 1982 - 31 December 1985	A.494(XII) / A.541(13)	A.494(XII)	A.494(XII)
1 January 1986 - 18 July 1994	A.494(XII) / A.541(13)	A.494(XII)	Not Eligible
After 18 July 1994	Not Eligible	Not Eligible	Not Eligible

\* Unless otherwise provided for in an International Convention or other instrument.

<sup>1</sup> The Interim Schemes for Tonnage Measurement do not apply to ships covered by article 3(2)(d) of the 1969 Tonnage Convention, and may be applied to an eligible ship for the life of the ship under interpretations established at MSC 50 (MSC 50/27). A third Interim Scheme for Tonnage Measurement, resolution A.540(13) for the STCW Convention, is no longer applicable as a result of the 1995 amendments to the Convention.

## Relevant requirements under international conventions

4 The term "relevant requirements under" in article 3(2)(d) of the 1969 Tonnage Convention and throughout this Recommendation refers to tonnage-based requirements for which a tonnage threshold was in effect on or before 18 July 1994, the date when the 1969 Tonnage Convention came fully into force. As such, national tonnage may not be used when applying newer tonnage thresholds in international conventions, unless otherwise provided in an international convention or other instrument. For example, for eligible ships, national tonnages may be used to apply the 500 gross tonnage cargo ship exemption threshold of regulation I/3 of SOLAS, which predates 18 July 1994. However, national tonnages may not similarly be used to apply the 500 gross tonnage threshold of SOLAS regulation XI-2/2.1.1.2, which came into effect after this date<sup>2</sup>.

## Remarks on International Tonnage Certificates (1969)

5 Notwithstanding the provisions of resolutions A.494(XII) and A.541(13), which state that gross tonnage measured under the national tonnage rules shall not be shown on the International Tonnage Certificate (1969), an entry may be made under "Remarks" on the International Tonnage Certificate (1969), to reflect the shipowner's decision to use national tonnages, as follows:

- .1 For ships covered by article 3(2)(d) of the 1969 Tonnage Convention,  
  
"The ship is remeasured according to article 3(2)(d) of the 1969 Tonnage Convention. The GROSS TONNAGE according to the measurement system previously in force to the measurement system of the International Convention on Tonnage Measurement of Ships, 1969, is: ... *(insert GRT tonnage)* ... RT, according to the regulations of ... *(insert country name)* ...."
- .2 For ships covered by resolution A.494(XII) and/or resolution A.541(13),  
  
"The ship is additionally measured according to resolution(s) ... *(insert A.494(XII) and/or A.541(13), as applicable)* ... The GROSS TONNAGE according to the measurement system previously in force to the measurement system of the International Convention on Tonnage Measurement of Ships, 1969, is: ... *(insert GRT tonnage)* ... RT, according to the regulations of ... *(insert country name)* ...."

## Remarks on other international certificates (1969)

6 For ships for which the International Tonnage Certificate (1969) includes a "Remarks" entry on national tonnage as described in paragraph 5 of this Recommendation, the appropriate box in the appropriate Ship Safety Certificate, the International Oil Pollution Prevention Certificate or other such official certificates issued by the Administration may show only that national gross tonnage with one of the following footnotes:

---

<sup>2</sup> Refer to the Interim Scheme for the compliance of certain cargo ships with the special measures to enhance maritime security (MSC/Circ.1157) for additional details. The Interim Scheme for the compliance of certain cargo ships and special purpose ships with the management for the safe operation of ships (MSC.1/Circ.1231) similarly addresses use of national tonnages in applying the SOLAS ISM Code.

"The above gross tonnage has been determined by the tonnage authorities of the Administration in accordance with the national tonnage rules which were in force prior to the coming into force of the International Convention on Tonnage Measurement of Ships, 1969"; or

"See REMARKS column of the valid International Tonnage Certificate (1969)."

#### **Removal of remarks**

7 Should a ship lose eligibility for using national tonnage to apply relevant requirements under international conventions by undergoing alterations or modifications which the Administration deems to be a substantial variation in its existing tonnage as described in article 3(2)(b) of the 1969 Tonnage Convention, the Administration should ensure associated certificates described in paragraphs 5 and 6 of this Recommendation are reissued or otherwise amended to delete reference to the ship's national tonnage.

\*\*\*



**ANNEX 23**

**RESOLUTION MSC.363(92)  
(Adopted on 14 June 2013)**

**PERFORMANCE STANDARDS FOR ELECTRONIC INCLINOMETERS**

THE MARITIME SAFETY COMMITTEE,

RECALLING Article 28(b) of the Convention on the International Maritime Organization concerning the functions of the Committee,

RECALLING ALSO resolution A.886(21), by which the Assembly resolved that the function of adopting performance standards and technical specifications, as well as amendments thereto, shall be performed by the Maritime Safety Committee and/or the Marine Environment Protection Committee, as appropriate, on behalf of the Organization,

NOTING that in the *Revised Guidance to the master for avoiding dangerous situations in adverse weather and sea conditions* (MSC.1/Circ.1228), information about heel angle and roll period is regarded as relevant for assessment of the ship's stability situation in adverse weather and sea conditions,

NOTING ALSO that, at its ninetieth session, it had adopted resolution MSC.333(90) on *Revised Performance standards for shipborne voyage data recorders (VDRs)*,

NOTING FURTHER that, at its eighty-eighth session, instead of adding the requirement for an electronic inclinometer to the performance standards for VDRs, it had decided to develop dedicated performance standards for inclinometers,

RECOGNIZING the need to define minimum requirements for a heel angle and roll period measurement device to ensure that heeling information is provided in a reliable manner on board ships to be used by the crew to assess the dynamic situation of the ship and to be available for marine casualty investigation,

HAVING CONSIDERED, at its ninety-second session, the draft Performance standards for electronic inclinometers prepared by the Sub-Committee on Safety of Navigation, at its fifty-eighth session,

1. ADOPTS the Performance standards for electronic inclinometers, set out in the annex to the present resolution;
2. RECOMMENDS Governments ensure that electronic inclinometers installed on or after 1 July 2015, conform to performance standards not inferior to those specified in the annex to the present resolution.

## ANNEX

### PERFORMANCE STANDARDS FOR ELECTRONIC INCLINOMETERS

#### 1 SCOPE

1.1 Electronic inclinometers are intended to support the decision-making process on board in order to avoid dangerous situations as well as assist in and facilitate maritime casualty investigations by providing information about the roll period and the heel angle of the ship.

1.2 Electronic inclinometers should, in a reliable form:

- .1 determine the actual heel angle with the required accuracy;
- .2 determine the roll amplitude with the required accuracy;
- .3 determine the roll period with the required accuracy;
- .4 present the information on a bridge display; and
- .5 provide a standardized interface to instantaneous heel angle to the voyage data recorder (VDR).

#### 2 APPLICATION OF THESE STANDARDS

2.1 These Performance standards should apply to all electronic inclinometers intended to support the decision-making process on board in order to avoid dangerous situations as well as to assist in maritime casualty investigations, if carried, on all ships<sup>1</sup>.

2.2 In addition to the general requirements set out in the *General requirements for shipborne radio equipment forming part of the Global Maritime Distress and Safety System (GMDSS) and for electronic navigation aids* (resolution A.694(17)<sup>2</sup>) and the presentation requirements set out in the *Performance standards for the presentation of navigation-related information on shipborne navigational displays* (resolution MSC.191(79)), electronic inclinometers should meet the requirements of these standards and follow the relevant guidelines on ergonomic principles<sup>3</sup> adopted by the Organization.

#### 3 DEFINITIONS

For the purpose of these Performance standards, the following definitions apply:

- .1 *Rolling* is the motion around the longitudinal axis of the ship;
- .2 *Actual heel angle* is the momentary angle of roll referenced to a levelled ship to port or starboard side;

---

<sup>1</sup> These Performance standards do not apply to electronic inclinometers installed for purposes which are outside the scope of these guidelines, e.g. monitoring of cargo status.

<sup>2</sup> Refer to IEC Publication 60945 – Maritime navigation and radiocommunication equipment and systems – General requirements.

<sup>3</sup> Refer to the *Guidelines on ergonomic criteria for bridge equipment and layout* (MSC/Circ.982).



- .3 *Roll period* is the time between two successive maximum values of heel angle on the same side of the ship; and
- .4 *Roll amplitude* is the maximum values of heel angle to port or starboard side.

## **MODULE A – SENSOR**

### **4 MEASUREMENT OF ACTUAL HEEL ANGLE**

Electronic inclinometers should be capable of measuring the actual heel angle and determining the amplitude of the rolling oscillation of the ship over a range of  $\pm 90$  degrees.

### **5 MEASUREMENT OF ROLL PERIOD**

Electronic inclinometers should be capable of measuring the time between the maximum values of the rolling oscillation and determining the roll period over a minimum range of 4 to 40 s.

### **6 ACCURACY**

6.1 Electronic inclinometers should provide the data with sufficient accuracy for a proper assessment of the ship's dynamic situation. Minimum accuracy of the measurements should be 5 per cent of reading or  $\pm 1$  degree, whichever is the greater for angle measurements and 5 per cent of reading or  $\pm 1$  s, whichever is the greater for time measurements.

6.2 Actual heel angle and time measurement accuracy should not be unduly affected by other linear or rotational movements of the ship (e.g. surging, swaying, heaving, pitching, yawing) or by transverse acceleration ranging from -0.8 g to +0.8 g.

## **MODULE B – OPERATIONAL AND FUNCTIONAL REQUIREMENTS**

### **7 DISPLAY REQUIREMENTS**

7.1 Electronic inclinometers should display:

- .1 the roll period with a minimum resolution of 1 s; and
- .2 the roll amplitude to both port and starboard side with a minimum resolution of 1 degree.

7.2 The actual heel angle to port or starboard should be indicated in an analogue form between the limits of  $\pm 45$  degrees.

7.3 The display may be implemented as a dedicated display or integrated into other bridge systems.

### **8 OPERATIONAL ALERTS**

Electronic inclinometers may optionally provide a warning for indicating that a set heel angle had been exceeded.

## **9 PERFORMANCE TESTS, MALFUNCTIONS AND INDICATIONS**

Electronic inclinometers should internally check and indicate to the user if all components are operative and if the information provided is valid or not.

## **MODULE C – INTERFACING AND INTEGRATION**

### **10 CONNECTIONS TO OTHER EQUIPMENT**

10.1 Electronic inclinometers should comprise a digital interface providing actual heel angle information to other systems like, e.g. VDR, with an update rate of at least 5 Hz. Electronic inclinometers should also comprise a digital interface providing the displayed information of roll period and roll amplitude (see paragraph 7.1).

10.2 Electronic inclinometers should have a bidirectional interface to facilitate communication, to transfer alerts from inclinometers to external systems and to acknowledge and silence alerts from external systems.

10.3 The digital interface should comply with the relevant international standards<sup>4</sup>.

### **11 INSTALLATION POSITION**

The installation position of the sensors of the electronic inclinometer should be recorded and made available for the configuration of the VDR.

### **12 POWER SUPPLY**

Electronic inclinometers should be powered from the ship's main source of electrical energy. In addition, it should be possible to operate the electronic inclinometers from the ship's emergency source of electrical energy.

\*\*\*

---

<sup>4</sup> Refer to standard IEC 61162 – Maritime navigation and radiocommunication equipment and systems – Digital interfaces.

**ANNEX 24**

**RESOLUTION MSC.364(92)  
(Adopted on 14 June 2013)**

**PROCEDURE FOR CALCULATING THE NUMBER OF FISHING VESSELS OF  
EACH CONTRACTING STATE TO THE 2012 CAPE TOWN AGREEMENT  
BY THE DEPOSITARY**

THE MARITIME SAFETY COMMITTEE,

RECALLING Article 28(b) of the Convention on the International Maritime Organization concerning the functions of the Committee,

NOTING WITH APPRECIATION the adoption, on 11 October 2012, of the Cape Town Agreement of 2012 on the Implementation of the Provisions of the Torremolinos Protocol of 1993 relating to the Torremolinos International Convention for the Safety of Fishing Vessels, 1977 (hereinafter referred to as "the Agreement"), by the 2012 International Conference on the Safety of Fishing Vessels, held in Cape Town, South Africa, from 9 to 11 October 2012,

RECOGNIZING the significant contribution to maritime safety in general and to that of fishing vessels in particular which can be made by implementation of the provisions of the Agreement,

NOTING that the Agreement, in accordance with article 4(1), shall enter into force 12 months after the date on which not less than 22 States, the aggregate number of whose fishing vessels of 24 m in length and over operating on the high seas is not less than 3,600, have expressed their consent to be bound by it,

NOTING ALSO Conference resolution 5, which requests the Maritime Safety Committee to develop a procedure for calculating the number of fishing vessels of each Contracting State to the Agreement by the Depositary at the earliest opportunity, but not later than 1 January 2014,

HAVING CONSIDERED, at its ninety-second session (12 to 21 June 2013), a Procedure for calculating the number of fishing vessels of each Contracting State to the Agreement by the Depositary, proposed by the Sub-Committee on Stability and Load Lines and on Fishing Vessels Safety, at its fifty-fifth session,

1. ADOPTS the Procedure for calculating the number of fishing vessels of each Contracting State to the 2012 Cape Town Agreement by the Depositary, the text of which is set out in the annex to the present resolution;
2. URGES States, when expressing their consent to be bound by the Agreement, to communicate to the Depositary the number of fishing vessels of 24 m in length and over (as defined in the 1993 Torremolinos Protocol) under their flag authorized to operate on the high seas;
3. ALSO URGES States to become a Contracting State to the Agreement as soon as possible to facilitate its early entry into force and cooperate with each other to achieve this end.

\* \* \*

## ANNEX

### **PROCEDURE FOR CALCULATING THE NUMBER OF FISHING VESSELS OF EACH CONTRACTING STATE TO THE 2012 CAPE TOWN AGREEMENT**

#### **General**

1 In order for the Depositary to calculate the number of fishing vessels of each Contracting State to the 2012 Cape Town Agreement, the procedure below is to be followed:

- .1 States, when expressing their consent to be bound by the Agreement, would be requested to communicate to the Depositary (the Secretary-General), the number of fishing vessels of 24 m in length and over (as defined in the 1993 Torremolinos Protocol) under their flag, authorized to operate on the high seas;
- .2 if the information in subparagraph .1 above is unavailable at the time of the expression of consent, the Depositary will contact the FAO Secretariat to request the numbers of fishing vessels of 24 m in length and over provided to FAO by a Contracting State which is Party to the FAO Agreement to promote compliance with international conservation and management measures by fishing vessels on the high seas (the Compliance Agreement); and
- .3 if the information in subparagraph .2 above is unavailable, the Depositary will obtain information from databases of Regional Fisheries Bodies (RFBs) or other international maritime databases, as appropriate, for the purpose of obtaining the number of fishing vessels of 24 m in length and over, authorized to operate on the high seas flying the flag of the Contracting State.

#### **Simplified procedure for Parties to the 1993 Torremolinos Protocol**

2 Article 3(4) of the 2012 Cape Town Agreement provides a simplified procedure for signature of the Agreement by Parties to the 1993 Torremolinos Protocol, whereby such States, having signed the Agreement in accordance with paragraph (2)(c) of article 3, shall be deemed to have expressed their consent to be bound by it 12 months after the day of its adoption.

3 For States using the simplified procedure, the Depositary will request them to confirm whether the number of fishing vessels reported to the Organization when that State expressed its consent to be bound by the 1993 Torremolinos Protocol meets the criteria of article 4(1) of the Agreement. In the event of no reply, the Depositary will use the procedures in paragraph 1.2 or 1.3 above for the purpose of article 4(1) of the Agreement.

#### **Confirmation and final determination of data**

4 In cases where the procedures in paragraph 1.2 or 1.3 above apply, the Depositary shall contact the Contracting State to the Agreement to confirm the number of fishing vessels obtained by the Depositary. The Contracting State will have a period of 60 days to confirm the number or to provide a more accurate number. In the event of no reply, the Depositary will use the number derived from the above procedures for the purpose of article 4(1) of the Agreement.

\*\*\*

**ANNEX 26**

**DRAFT ASSEMBLY RESOLUTION**

**NOTIFICATION AND CIRCULATION THROUGH THE  
GLOBAL INTEGRATED SHIPPING INFORMATION SYSTEM (GISIS)**

THE ASSEMBLY,

RECALLING article 15(j) of the Convention on the International Maritime Organization concerning the functions of the Assembly in relation to regulations and guidelines concerning maritime safety and the prevention and control of marine pollution from ships,

RECALLING ALSO that one of the goals of the Organization is to ensure the consistent and effective implementation of IMO instruments globally and compliance with their requirements,

RECALLING FURTHER that, since 2004, the Strategic Plan for the Organization has promoted the effective use of information and communication technology and the availability of, and access to, information relating to ship safety and security and environmental protection (i.e. transparency),

RECALLING IN PARTICULAR that, by resolution A.1029(26) on the *Global Integrated Shipping Information System (GISIS)*, it recognized that GISIS aims at facilitating, inter alia, Member States' compliance with reporting requirements, and urged Member States specifically to use GISIS reporting facilities to sustain and enhance compliance with mandatory reporting requirements, as contained in those mandatory instruments to which they are Parties, thereby potentially assisting them in the context of the Voluntary IMO Member State Audit Scheme,

NOTING WITH SATISFACTION that GISIS has been continuously developed and additional modules have been released since its launch in 2005 in order to allow a wider coverage of direct reporting by Member States in compliance with existing requirements,

RECOGNIZING that, to promote the implementation of mandatory IMO instruments, the effective use of information and communication technology would contribute significantly to all Member States fulfilling their obligations of mandatory reporting and the circulation of any such notification by the Organization could be achieved through the GISIS system,

RECOGNIZING ALSO the important role the system could play in respect of enhancing the rate of notification and potentially reducing the administrative burden for the Contracting Governments or Parties,

RECOGNIZING FURTHER the fact that, once the Organization has been notified through GISIS by a Contracting Government or Party, the related mandatory report would also become accessible to other Contracting Governments or Parties through GISIS, and the administrative burden of the Organization could be reduced,

HAVING CONSIDERED the recommendation made by the Facilitation Committee, at its thirty-eighth session, the Marine Environment Protection Committee, at its sixty-fifth session, and the Maritime Safety Committee, at its ninety-second session,

1. AGREES that notification through GISIS should be considered as one effective way for Contracting Governments or Parties to IMO instruments to fulfil their reporting obligations under the various mandatory IMO instruments;
2. FURTHER AGREES that once Contracting Governments or Parties have notified through GISIS in respect of a reporting requirement to the Organization, the requirement for the Organization to circulate any such notification under the IMO instrument concerned would have been met;
3. URGES Member States to use the reporting facilities available through GISIS to fulfil their reporting obligations under the various IMO instruments and to work towards the improvement of the quality of the data being collected through GISIS by implementing comprehensive validation processes when entering data into the system;
4. REQUESTS the Secretary-General to continue developing the system, particularly its modules related to mandatory reporting requirements, in close cooperation with Member States, IMO organs, international organizations and all other stakeholders of the global maritime community, as appropriate.

\*\*\*

**ANNEX 27**

**DRAFT ASSEMBLY RESOLUTION**

**GUIDELINES TO ASSIST INVESTIGATORS IN THE IMPLEMENTATION  
OF THE CASUALTY INVESTIGATION CODE  
(RESOLUTION MSC.255(84))**

THE ASSEMBLY,

RECALLING Article 15(j) of the Convention on the International Maritime Organization concerning the functions of the Assembly in relation to regulations and guidelines concerning maritime safety and the prevention and control of marine pollution from ships,

NOTING WITH CONCERN that, despite the best endeavours of the Organization, casualties and incidents resulting in loss of life, loss of ships and pollution of the marine environment continue to occur,

NOTING ALSO that the safety of seafarers and passengers and the protection of the marine environment can be enhanced by timely and accurate reports identifying the circumstances and causes of marine casualties and incidents,

NOTING FURTHER the rights and obligations of coastal and flag States under the provisions of articles 2 and 94 of the United Nations Convention on the Law of the Sea (UNCLOS),

NOTING IN ADDITION the responsibilities of flag States under the provisions of the International Convention for the Safety of Life at Sea (SOLAS, regulation 1/21), the International Convention on Load Lines, 1966 (article 23) and the International Convention for the Prevention of Pollution from Ships (MARPOL, article 12), to conduct casualty investigations and to supply the Organization with relevant findings,

CONSIDERING that each Administration shall conduct investigations of marine casualties and incidents, in accordance with SOLAS regulation XI-1/6, as supplemented by the provisions of the *Code of the international standards and recommended practices for a safety investigation into a marine casualty or marine incident (Casualty Investigation Code)* adopted by resolution MSC.255(84),

ACKNOWLEDGING that the investigation and proper analysis of marine casualties and incidents can lead to greater awareness of casualty causation and result in remedial measures, including better training, for the purpose of enhancing safety of life at sea and protection of the marine environment,

RECOGNIZING the need for *Guidelines to assist investigators in the implementation of the Casualty Investigation Code* (resolution MSC.255(84)) to provide, as far as national laws allow, a common approach for States to adopt in the conduct of marine safety investigations into marine casualties and marine incidents,

RECOGNIZING ALSO the international nature of shipping and the need for cooperation between Governments having a substantial interest in a marine casualty or incident for the purpose of determining the circumstances and causes thereof,

HAVING CONSIDERED the recommendations made by the Maritime Safety Committee, at its ninety-second session, and by the Marine Environment Protection Committee, at its sixty-fifth session:

1. ADOPTS the *Guidelines to assist investigators in the implementation of the Casualty Investigation Code* (resolution MSC.255(84)), as set out in the annex to the present resolution;
2. INVITES all Governments concerned to take appropriate measures to give effect to the Guidelines as soon as possible in order to allow effective analysis when conducting a marine safety investigation and taking preventive actions;
3. REVOKES resolutions A.849(20) and A.884(21).

\* \* \*



ANNEX

**GUIDELINES TO ASSIST INVESTIGATORS IN THE IMPLEMENTATION  
OF THE CASUALTY INVESTIGATION CODE (RESOLUTION MSC.255(84))**

**1 INTRODUCTION**

1.1 The purpose of these Guidelines is to provide practical advice for the systematic investigation of marine casualties and incidents and to allow the development of effective analysis and preventive action. The overall objective is to prevent similar casualties and incidents in the future.

1.2 The ultimate purpose of a marine safety investigation is to advance maritime safety and protection of the marine environment. In the context of these Guidelines, this goal is achieved by identifying safety deficiencies through a systematic safety investigation of marine casualties and incidents, and then recommending or effecting change in the maritime system to correct these deficiencies. It is not the purpose of a safety investigation to determine liability or apportion blame.

1.3 These Guidelines should result in an increased awareness by all involved in the marine industry of the human, organizational, environmental, technical and external factors that may be involved in marine casualties and incidents. This awareness should lead to proactive measures by the maritime community which in turn should result in the saving of lives, ships, cargo and the protection of the marine environment, improvements to the lives of marine personnel, and safer shipping operations.

1.4 These Guidelines apply, as far as national laws allow, to the investigation of marine casualties or incidents in which either one or more States have a substantial interest because the casualty or incident involves a ship under or within their jurisdiction.

**2 DEFINITIONS**

**2.1 Table of definitions**

See chapter 2 of the Casualty Investigation Code (resolution MSC.255(84)) for terms not defined in these Guidelines.

Event	An action, omission or other happening.
Casualty event	The marine casualty or marine incident, or one of a number of connected marine casualties and/or marine incidents forming the overall occurrence. (e.g. a fire leading to a loss of propulsion leading to a grounding).
Accident event	An event that is assessed to be inappropriate and significant in the sequence of events that led to the marine casualty or marine incident. (e.g. human erroneous action, equipment failure, etc.).
Contributing factor	A condition that may have contributed to an accident event or worsened its consequence. (e.g. man/machine interaction, inadequate illumination, etc.).
Safety issue	An issue that encompasses one or more contributing factors and/or other unsafe conditions.
Safety deficiency	A safety issue with risks for which existing defences aimed at preventing an accident event, and/or those aimed at eliminating or reducing its consequences, are assessed to be either inadequate or missing.

2.2 The following diagram illustrates how a sequence of events leading to a casualty occurrence would be classified using the above terms.

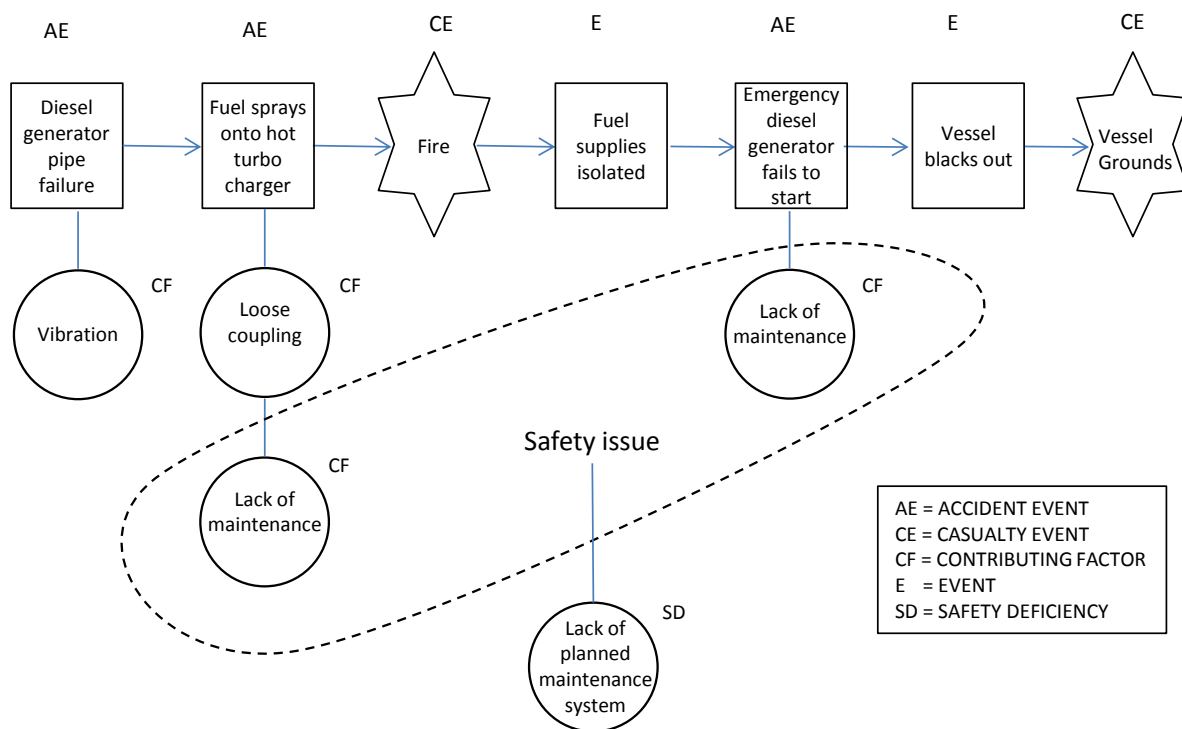

### 3 QUALIFICATIONS AND TRAINING OF INVESTIGATORS

3.1 To achieve a systematic and effective safety investigation the appointed investigators need to have expertise in marine casualty investigation and be knowledgeable in matters relating to the marine casualty or incident. Areas of expertise need to include evidence collection techniques, interview techniques, analysis techniques and the identification of human and organizational factors in marine casualties and incidents.

3.2 All investigators attending a marine casualty site should have sufficient knowledge in personal safety, taking particular note that the hazards present at a casualty site may well be beyond those encountered in normal ship operations.

3.3 A Marine Safety Investigation Authority should consider developing a formal training programme to ensure that its investigators acquire the necessary knowledge, understanding and proficiency in marine safety investigation.

### 4 NOTIFICATION AND COOPERATION

4.1 Notification of a marine casualty or incident is to be provided to all affected parties as soon as reasonably practicable. Notification includes informing the parties involved in the casualty or incident according to chapter 20 of the Code, as well as any substantially interested State in accordance with chapter 5 of the Code. Notification should preferably be in a format that ensures a prompt acknowledgement from the addressee.

4.2 If the casualty or incident involves substantial interests of more than one State, the States should quickly reach an agreement on cooperation in accordance with chapter 7 of the Code. This agreement may include, but not be limited to:

- .1 ensuring that that the objectives of each participating State is in accordance with the IMO Casualty Investigation Code;
- .2 which State will lead the investigation;
- .3 the possibilities to share casualty information, and draft safety investigation reports in accordance with chapter 13 of the Code, with regard to national legislation on confidentiality as well as the potential risk of safety investigation findings being used in criminal and civil lawsuits; and
- .4 distribution of costs related to the investigation.

4.3 If an agreement in accordance with the Code, chapter 7, cannot be made, the involved States should seek to share factual information to the greatest extent possible, being guided by the recommended practice in the Code.

## **5 INVESTIGATION**

### **5.1 Extent of investigation**

5.1.1 Marine casualties and incidents can have many causal factors and the underlying safety issues often exist remote from the casualty site. Proper identification of such issues requires timely and methodical investigation, going far beyond the immediate evidence in search for conditions which may cause future occurrences. Marine casualty or incident safety investigations should therefore be seen as a means of identifying not only the accident events, but also safety deficiencies in the overall management of the operation from policy through to its implementation, as well as in regulation, survey and inspection. For this reason safety investigations should be broad enough to meet these overriding criteria.

5.1.2 The extent of any safety investigation can be divided into five areas:

- .1 people;
- .2 environment;
- .3 equipment;
- .4 processes and procedures; and
- .5 organization and external influences.

### **5.2 Initial response**

An investigation should be carried out as soon as possible after an occurrence so as to limit the loss of perishable evidence including the degradation of witness memory. To be able to start promptly it is essential that the investigating State has a preparedness plan in place which among other things, will facilitate:

- .1 the ready availability of trained investigators;
- .2 the availability of specialist help, including human and organizational factors experts;
- .3 ready access to 24-hour contact points for other Marine Safety Investigation Authorities; and
- .4 the availability of the necessary predictable resources.

### **5.3 Site management**

5.3.1 Site management generally starts even before the investigator deploys to the casualty site. The pre-planning will often need to include:

- .1 identification of competencies needed at the casualty site;
- .2 identification of hazards and risks that the team may encounter at the casualty site, and the precautions that need to be taken, as well as the personal protective equipment (PPE) that needs to be carried;
- .3 identification of particularly vulnerable evidence that needs to be secured as soon as possible including VDR information, documentation of sites that for some reasons cannot be left unchanged until the team arrives, and repatriation of crew members; and
- .4 a draft interview schedule taking into account repatriation of seamen as well as the fact that persons involved can suffer from trauma.

5.3.2 There can be many different stakeholders involved in the aftermath of a marine casualty or incident, each with their own legitimate interests and responsibilities. Coordination at the casualty site is vital to make the evidence collection successful.

5.3.3 When arriving at the casualty site the hazard and risk assessment should be reviewed to identify any additional risks for the team and to put in place any necessary remedial action before the team starts its work.

### **5.4 Start-up meeting**

In safety investigations involving more than one State it is generally wise to set up a meeting with representatives of the other substantially interested States at an early stage. The purpose of the start-up meeting is, among other things, to facilitate:

- .1 the sharing of knowledge of what is known about the marine casualty or incident;
- .2 the development of an investigation plan;
- .3 the delegation of investigation tasks (international coordination); and
- .4 the identification of additional help in the form of specialists and/or technical expert examination.

### **5.5 Collection of evidence**

5.5.1 During the safety investigation, investigators should aim to gather and record all the evidence and factual data which may be of interest within the scope of the investigation. Physical and documentary evidence and witness statements should be gathered not only at the casualty site, but from all sources required to fully explain the accident events and their contributing factors to the accident (e.g. operation, management, inspection and regulation).

5.5.2 Evidence collection also needs to be broad enough to cover the human, organizational and environmental factors in relation to the casualty or incident. If a human and organizational factor specialist is required, it is essential to include this expert as early as possible in the investigation team.

5.5.3 To facilitate a comprehensive evidence collection it is often wise to:

- .1 refer to generic checklists but remain flexible as evidence once collected will often point out new areas of inquiry; and
- .2 use a system to register the evidence collected (Evidence log). This is particularly valuable in complex investigations or when more than one State is involved.

5.5.4 It is recommended that the fact-finding stage of the investigation process itself be kept separate from the complete analysis of the collected evidence leading to conclusions and recommendations. Fact finding usually includes, but is not necessarily limited to the areas covered in sections 5.6 to 5.10.

## **5.6 Inspection of casualty site**

5.6.1 Inspection and documentation of the casualty site and/or places of interest for the investigation can include inspection of the ship/ships involved, a fairway where the casualty or incident occurred, and underwater survey and filming of the wreckage of a ship.

5.6.2 The collection of evidence that can deteriorate or disappear over time will always be the first priority in evidence collection when the investigator(s) arrives at the casualty site. Photo and/or video documentation of the site in general and in detail, and before any removal of evidence, is generally also of a high priority.

5.6.3 Where there is perishable evidence and the investigator(s) may be delayed in arriving at the casualty site, there may be a need to give instructions for the evidence to be preserved.

## **5.7 Gathering or recording physical evidence**

5.7.1 Physical evidence can include data from VDR and other electronic devices on board like electronic charting systems, central fire alarm units, as well as nautical charts, weather forecasts obtained on board, and logbooks. Physical evidence can also include technical samples of oil, paint, or fire residues, and pieces of broken machinery or other broken parts.

5.7.2 It is essential that the person who collects electronic, documentary or material evidence is skilled in applicable techniques for both collection and storage of that type of evidence to prevent contamination, further deterioration or loss.

5.7.3 Some information of great value can also be obtained from external sources such as CCTV, shore radar and radio surveillance systems and Marine Rescue Coordination Centres. VTS centres may also be able to provide valuable information, including recordings of radio traffic and AIS information.

## **5.8 Witness information**

5.8.1 Witness interviews should be performed by persons skilled in interviewing techniques to reveal information the witness may be able to provide. The planning of the interview is essential for a successful outcome. Things to be considered include:

- .1 time and location;
- .2 any need of interpreters;

- .3 make-up of the interview team and the roles of the team members;
- .4 the particular needs of the witness; and
- .5 the topic areas to be explored with the witness.

5.8.2 The interviewed person should be informed, before the interview starts, about the purpose of the investigation and the conditions under which he/she will be providing information. The witness should generally be interviewed singly, or accompanied by someone nominated by the witness. The nominated individual should, however, not be allowed to interfere with the interview. The witness should under all circumstances be allowed access to legal advice if he/she wants it (see chapter 12 of the Code).

5.8.3 The interview might be recorded or a written record could be made of the interview. A written record should be discussed with the witness to clarify any anomalies. Witness information should be verified wherever possible. Statements made by different witnesses may conflict and further supporting evidence may be needed.

## **5.9 Reviewing of documents, procedures and records**

5.9.1 Documents to be reviewed can include personal and ship-related certificates, reports from the ship's classification society, maintenance records, the Master's standing orders, etc. An assessment may also be made of the company's Safety Management System from its safety policy through to its implementation within the organization.

5.9.2 Government agencies, such as customs, quarantine and State Authorities may have useful information relating to crew lists, the general condition of the ship, ship certificates, etc. Coroners and medical records can provide valuable information. Port authorities and independent surveyors can also hold information of use to an investigation. Applicable regulations may also need to be examined.

5.9.3 A good investigation explores the extent of correlation between the documents and reality at all appropriate levels: this will generally require some specialist skills.

## **5.10 Conducting specialized studies (as required)**

5.10.1 It can sometimes be necessary to conduct specialized studies to establish how a casualty or incident happened. This can include, for example, metallurgic specialist studies of broken machinery parts, analysis of oil or paint residues, calculation and reconstruction of a ship's stability features, lashing calculations, specialist analysis of weather and sea conditions at the time and place of the casualty or incident, and the use of simulators to reconstruct and analyse a sequence of events.

5.10.2 Where a proposed testing of physical evidence is likely to change its state, other interested parties who may be relying on that evidence should be consulted.

## **5.11 Reconstruction and analysis**

5.11.1 There are several different methods of organizing evidence to support reconstruction and analysis in safety investigation, each having its own benefits and drawbacks. To ensure that a casualty or incident is thoroughly examined from a safety point of view, it is essential that the investigation is done with a systemic perspective. A systemic perspective involves going beyond determining "who did what?" and to look for the conditions that influenced different relevant events, even when these conditions are to be

found remote from the casualty site. A systemic perspective also puts human factors into context and includes the interactions between man, machine and the organization.

5.11.2 The analysis methods used will help the investigator to think in a structured way but will also have an effect on where the investigator will put his/her focus. Some methods focus on human factors; some support the understanding of the sequence of events; others are more supportive in complex safety analysis or in understanding technical failures. Analysis methods should therefore rather be seen as tools in a tool box. A good investigation will choose the optimal set of analysis tools to meet the characteristics of that particular casualty or incident. However, the method or the combination of methods used in each investigation should as a minimum requirement support:

- .1 reconstruction of the casualty or incident as a sequence of events;
- .2 identification of linked accident events and contributing factors at all appropriate levels; and
- .3 safety analysis and development of recommendations.

## **5.12 Reconstruction of the casualty events and their linked conditions**

5.12.1 The first step in analysis is to review the factual information to clarify what is relevant and what is not, and to ensure the information is as complete as possible or practicable. This stage of the analysis should aim at determining how the marine casualty or incident occurred. The reconstruction is preferably done by using a method that enables a graphical description of the sequence of events. This is beneficial since it allows the investigator to discuss and present the case, and in particular to:

- .1 identify gaps in the information;
- .2 identify any conflicts in evidence;
- .3 provide a graphical description of how different events are related; and
- .4 identify contributing factors and their relation to different accident events.

5.12.2 Marine casualty or incident investigation is an iterative process and the reconstruction phase generally identifies a need to make a revision of the evidence collection plan.

## **5.13 Safety analysis**

The purpose of a safety analysis is to get a more thorough understanding of the underlying safety issues that can cause or contribute to a casualty or incident. Some investigation analysis methods combine casualty reconstruction and safety analysis into one. Some basic analysis methods can be directly linked to the reconstruction of events, while other safety analysis tools can be derived from different accident causational models and are better used as stand-alone methods. Efficient safety analysis tools:

- .1 encourage different perspectives of casualty or incident causation;
- .2 support communication and deeper questioning;

- .3 enable the identification of safety issues and safety deficiencies, including those remote from the casualty site; and
- .4 enhance the development of effective remedial actions at all appropriate levels.

## **6 REPORTING**

### **6.1 Reporting requirements**

6.1.1 MSC-MEPC.3/Circ.[4] requires particular marine casualty data to be entered into the GISIS marine casualties and incidents module, together with the final version of a marine safety investigation report.

### **6.2 Final report**

6.2.1 To facilitate the flow of information, the final report of the safety investigation should be well structured and cover what is listed in paragraph 2.12 of the Code. The report should, within its different parts, clearly distinguish between facts and analysis.

6.2.2 The singleness of purpose to enhance maritime safety and protection of the marine environment should be reflected in the non-judgmental language used in the report. Witnesses' names and personal information which may identify them should remain confidential.

6.2.3 In normal investigation practice, gaps in information that cannot be resolved are usually filled by logical extrapolation and reasonable assumptions. Such extrapolation and assumptions should be identified and a statement of the measure of certainty provided. Despite best efforts, analysis may not lead to firm conclusions. In these cases, the more likely hypotheses should be presented.

6.2.4 If safety recommendations are issued these should be addressed to those that are best placed to implement them, such as shipowners, managers, recognized organizations, maritime authorities, vessel traffic services, emergency bodies, and international and regional maritime organizations and institutions. Safety recommendations should always be supported by the facts and analysis of the safety investigation. To gain acceptance, recommendations need to be practical, necessary and likely to be effective.

6.2.5 Where it becomes apparent during an investigation that there is a safety deficiency that presents a serious potential risk to lives, ships or the environment, action should be taken to inform the people or organization responsible for managing the risk. This may take the form of an interim safety recommendation or some other means of correspondence. It is important not to delay action to address such safety risks until the completion of the investigation.

### **6.3 Consultation**

6.3.1 In accordance with paragraphs 25.2 and 25.3 of the Code, where it is practicable, the investigator should send a copy of a draft marine safety investigation report for comment to the interested parties as defined in paragraph 2.7 of the Code. This allows a process for correcting matters of fact within a report and the consideration of alternative hypotheses or opinions in relation to the analysis. In addition, it allows responsible parties, e.g. the ship operator, to indicate what safety action may have been taken in relation to a safety issue. Any such action taken should be included in the final report.



6.3.2 The investigator should consider the comments before preparing the final marine safety investigation report, being guided by paragraph 25.3 of the Code.

#### **6.4 Publication**

6.4.1 The final report should be made available to the public and the shipping industry in accordance with paragraph 14.4 of the Code. The Internet is a valuable tool for making a report available to the public.

6.4.2 A summary of the marine safety investigation report and any safety recommendations, translated into English and/or other major languages, will enable a global public to gain important safety information from the investigation.

#### **6.5 Follow-up on safety recommendations**

6.5.1 Every recommendation addressed to an individual or specific organization should be followed up within a reasonable period following the release of a final safety investigation report with a view to promoting safety action. It is also good practice to reinforce positive safety action to address a recommendation by making it public. Similarly, the fact that no action has been taken by those responsible for implementing a recommendation should also be published.

\* \* \*

## Appendix 1

### AREAS OF HUMAN AND ORGANIZATIONAL FACTORS INQUIRY

The areas of inquiry set out in this appendix can be used in planning the investigation of human and organizational factors during a maritime safety investigation. Some areas of inquiry overlap or indeed incorporate multiple interactions. The guidance is not meant to be exhaustive, nor is it intended to be a checklist where each point must be investigated every time. Some areas may not be relevant in the investigation of a particular occurrence, while other areas may require deeper investigation. As new human and organizational factors/issues emerge, new areas of inquiry will need to be explored by investigators.

Skilful interviewing can help the investigator eliminate irrelevant lines of inquiry and focus on areas of greater potential significance. The order and manner in which questions are asked will depend on who is being interviewed and on his or her willingness and ability to recall and describe personal behaviour and personal impressions. Training in cognitive interviewing techniques will assist investigators in eliciting accurate information from interviewees, and is highly recommended. Further, because human interactions, including interviews, are subject to misunderstanding, it will normally be necessary to verify, cross-check or augment information received from one person by interviewing others on the same subjects.

While important human and organizational factors/information can be gained through interview, investigators must ensure that they also seek additional information through other means. Examination of rosters, procedures, personnel records, safety occurrence reporting records and risk assessment protocols (for example) may provide critical insights into practices, norms and attitudes potentially affecting safety.

#### SHIPBOARD ISSUES

##### 1 Training and experience

- Position or rank held.
- Certificate held; length of time the certificate has been held; where trained.
- Experience in the position; both on this ship and over career.
- Length of time on this contract and overall on board the ship.
- Experience on other ships; both with this company and other companies.

##### 2 Shipboard organizational structure and processes

- The management/department structure on board the ship.
- The individual's position within the on board structure; who they work for, who they work with, who they report to and who they assign duties to.
- Normal day-to-day responsibilities, tasks and duties.
- Description of any interworking with personnel ashore.

### **3 Nature of tasks**

- Specifics of the task(s) being undertaken at the time of the occurrence, including location.
- Differences between the task at that time and normal operations.
- Description of the social dynamics of the working environment (e.g. alone/pair/team).
- Understanding of the task.
- Familiarity with the task; last time it was performed, etc.
- Available discretion relating to how the task was to be accomplished.
- Training provided for the task; what was the training.
- Procedures, documents and guidance for the task.
- Equipment used for the task; reliability, previous failures, problems and were the crew familiar with it.
- Physical environment; heat, humidity, noise, confined space, exposure to chemicals, etc.
- Workload and/or effort required for the task:
  - To what extent was it within their capability at the time.
  - Were there any tasks that they did not do because of the workload on this task.
  - Physical effort involved; pushing, pulling, lifting, etc.
  - Mental effort involved; thinking, deciding, calculating, remembering, looking, searching, etc.
  - Time pressure involved; adequacy of time allocated to the task.
  - Use of scaling questions may assist here. (e.g. "on a scale of 1 to 10, where 1 is very easy and 10 is extremely difficult, how (physically) difficult was this task ...").

### **4 Activities prior to occurrence**

- Actions and/or activities before coming on watch or reporting for duty.
- Individual's role in the operation being conducted by the ship at the time of the occurrence.
- Individual's location on board at the time of the occurrence.
- What was being observed immediately prior to the occurrence; what was seen, heard, felt, smelled, and thought about.

## **5 Work-period/rest-period/recreation pattern**

- Description of normal duty schedule (e.g. day worker or watchkeeper).
- Description of duty schedule on the day of the occurrence; the day before and during the week before the occurrence.
- Length of time awake and/or on duty at the time of the occurrence.
- Overtime worked on the day of the occurrence; the day before and during the week before the occurrence.
- Usual sleep/rest routine (What time to sleep and awake).
- Sleep/rest routine in the three days (72 hours minimum) leading up to the occurrence:
  - 72-hour history of time to bed/time to sleep/duty times/nap times.
  - If there is an indication of reduced sleep beyond 72 hours, collect sleep information beyond 72 hours (as a guide, back to two good nights' rest prior to the occurrence).
  - Quality of sleep; disturbances, light sleep, waking, how refreshed when waking.
  - Time of day when sleep is taken (impact on quality).
  - Last extended period of off-duty time.

## **6 Living conditions and shipboard environment**

- Description of the adequacy of personal facilities; individual, shared or communal; noisy, cramped, vibrations, temperature, ship's motion, etc.
- Availability and consumption of alcohol and/or non-prescribed medications.

## **7 Physical health**

- Symptoms of illness experienced within the 72 hours before the occurrence.
- Medications taken (prescription, non-prescription).
- Description of the last meal consumed prior to the occurrence; what and when.
- Description of existence and regularity of exercise routine.
- Details of any recent medical examinations, illnesses or injuries.
- Details of any regular or irregular medication, both prescribed and non-prescribed.
- Description of quality of vision (corrective lenses, etc.).
- Description of quality of hearing (hearing aids, etc.).
- Name and contact details of personal physician.

**8 Mental health**

- Length of time spent away from family or loved ones.
- Extreme emotions at any time in the days before the occurrence; e.g. feelings of extreme sadness, anger, worry, fear (use scaling questions (1 to 10) to determine level).
- Important and/or difficult personal decisions made recently; e.g. financial or family worries.
- Recent work performance; any concerns from others.
- Stress and/or difficult situations whilst on board and how these were being managed.
- Difficulties with concentration.
- Any mental health issues recently and/or in the past.
- Medications taken (prescription, non-prescription).

**9 Working relationships**

- Friendships and/or support from other crew members.
- Conflicts and/or clashes with other crew members or supervisors.
- Trust in other crew members.
- Language barriers interfering with work performance.
- Clarity of roles and responsibilities with other crew members.

**10 Employment conditions**

- Contractual arrangements.
- Complaints or industrial action and systems for resolution of these.
- Recent changes to employment conditions.

**11 Safety policy**

- Awareness of the company's safety policy.
- Ship's procedures for dealing with safety issues; methods of reporting and addressing safety concerns.
- Safety training; type, nature and frequency.
- Emergency drills; type, nature of and frequency.
- Personal protective equipment (PPE) provided.
- Records and/or knowledge of personal accidents or injuries prior to the occurrence.

## **12 Staffing levels**

- Sufficiency of staffing/crew levels on board.
- Appropriate allocation of crew members to duties.
- Changes to normal staffing/crew levels.

## **13 Standing orders**

- Master's standing orders; for all or part of the crew.
- How are the orders communicated.
- Are the orders in accordance with the company policies.

## **14 Level of automation and reliability of equipment**

- Complexity of machinery and automated systems.
- Training provided for systems.
- Competency of crew in using the systems.
- Reliability of systems; any earlier failures.
- Maintenance of systems.
- Are the systems integrated with each other and the task needs.

## **15 Ship design, motion/cargo characteristics**

- Ship design, motion or cargo characteristics; any features which interfere with human performance (e.g. obstructed watchkeeper vision).

## **SHORESIDE MANAGEMENT ISSUES**

### **16 Management policies and procedures**

- Existence and opinion of the effectiveness of the safety management system, including auditing, analysis, reporting and occurrence investigation.
- Existence and opinion of the effectiveness of risk assessment and management policies and procedures relating to ships, personnel and the environment.
- Existence and opinion of the effectiveness of the role of the Designated Person Ashore (DPA).

### **17 Scheduling of work and rest periods**

- The company's work schedule, relief policy and fatigue risk management policy.
- Adherence to these policies.
- Recent changes to these policies.

**18 Staffing levels**

- The company's policies and practices for determining staffing/crew levels on board ships.
- The effectiveness of these policies and practices.

**19 Assignment of duties**

- The company's policies for determining watchkeeping practices and other duties on board the ship.
- The actual watchkeeping practices.

**20 Shore-ship-shore support and communications**

- Means and level of support for the ship's master in conduct of operations.
- The master's reporting requirements.

**21 Voyage planning and port call schedules**

- Policies, procedures and guidelines provided to the master to enable voyage planning
- Actual practices for voyage planning.

**22 Recreational facilities**

- The company's policies and practices for the provision of welfare and recreational services on board.

**23 Contractual and/or industrial arrangements and agreements**

- Contractual arrangements for all crew members.
- Complaints or industrial action in the last year.

**24 National/international requirements**

- Appropriateness of the applicable international conventions and flag State regulations.
- Effectiveness of the flag State's implementation of the requirements and recommendations of the applicable international conventions.
- Compliance with the requirements and recommendations of the applicable international conventions and flag State regulations.

\*\*\*





**ANNEX 28**

**DRAFT ASSEMBLY RESOLUTION**

**AMENDMENTS TO THE SURVEY GUIDELINES UNDER THE HARMONIZED  
SYSTEM OF SURVEY AND CERTIFICATION (HSSC), 2011**

THE ASSEMBLY,

RECALLING Article 15(j) of the Convention on the International Maritime Organization concerning the functions of the Assembly in relation to regulations and guidelines regarding maritime safety and the prevention and control of marine pollution from ships,

RECALLING ALSO the adoption by:

- (a) the International Conference on the Harmonized System of Survey and Certification, 1988, of the Protocol of 1988 relating to the International Convention for the Safety of Life at Sea, 1974 and of the Protocol of 1988 relating to the International Convention on Load Lines, 1966, which, inter alia, introduced the harmonized system of survey and certification into the International Convention for the Safety of Life at Sea, 1974 and the International Convention on Load Lines, 1966, respectively;
- (b) resolution MEPC.39(29) of amendments to introduce the harmonized system of survey and certification into the International Convention for the Prevention of Pollution from Ships, 1973, as modified by the 1978 Protocol relating thereto (MARPOL);
- (c) resolution MEPC.132(53) of amendments to introduce the harmonized system of survey and certification into MARPOL Annex VI; and
- (d) the resolutions given below of amendments to introduce the harmonized system of survey and certification into:
  - (i) the *International Code for the Construction and Equipment of Ships Carrying Dangerous Chemicals in Bulk (IBC Code)* (resolutions MEPC.40(29) and MSC.16(58));
  - (ii) the *International Code for the Construction and Equipment of Ships Carrying Liquefied Gases in Bulk (IGC Code)* (resolution MSC.17(58)); and
  - (iii) the *Code for the Construction and Equipment of Ships Carrying Dangerous Chemicals in Bulk (BCH Code)* (resolutions MEPC.41(29) and MSC.18(58)),

RECALLING ALSO that, by resolution A.1053(27), it adopted the *Survey Guidelines under the Harmonized System of Survey and Certification (HSSC), 2011* (hereinafter referred to as "the Survey Guidelines") with a view to assisting Governments in implementing the requirements of the aforementioned instruments,

RECOGNIZING the need for the Survey Guidelines to be further revised to take account of the amendments to the IMO instruments referred to above, which have entered into force or become effective since the adoption of resolution A.1053(27),

HAVING CONSIDERED the recommendations made by the Marine Environment Protection Committee, at its sixty-fifth session, and the Maritime Safety Committee, at its ninety-second session,

1. ADOPTS the amendments to the *Survey Guidelines under the Harmonized System of Survey and Certification (HSSC), 2011*, as set out in the annex to the present resolution;
2. INVITES Governments carrying out surveys required by the relevant IMO instruments to apply the provisions of the annexed Survey Guidelines;
3. REQUESTS the Maritime Safety Committee and the Marine Environment Protection Committee to keep the Survey Guidelines under review and amend them as necessary.

\* \* \*

ANNEX

**AMENDMENTS TO THE SURVEY GUIDELINES UNDER  
THE HARMONIZED SYSTEM OF SURVEY AND CERTIFICATION, 2011  
(RESOLUTION A.1053(27))**

*Note: The struck-out text indicates deletions and the underlined text shows additions or changes to the Survey Guidelines.*

1 Amendments to General – 1 Introduction:

1.2 These Guidelines take into account amendments to statutory instruments which have entered into force up to and including 31 December ~~2011~~2013 (see appendix 1) and contain the following:

2 Amendments to General – 3 Application and Arrangement of the Guidelines

3.4 When appropriate, the detailed requirements for the various surveys contain a section that is applicable to all cargo ships followed by a section that only applies to ~~oil tankers~~ specific ship types.

3.8bis For the application of these Guidelines, the following guidance on terms used in the survey requirements is provided:

.1 "Examining" except where used in "examining the plans" or "examining the design" should be understood as a thorough examination, using appropriate techniques, of the components, system or appliance in question for satisfactory provision, arrangement and condition and for any signs of defects, deterioration or damage;

.2 "Testing" should be understood as a functional test of the system or appliance in question, to confirm its satisfactory operation and performance for its intended use.

3 Amendments to annex 1 – Survey Guidelines under the 1974 SOLAS Convention as modified by the 1988 Protocol relating thereto – (E) 1 Guidelines for Surveys for the Cargo Ship Safety Equipment Certificate:

(EI) 1.1.1.1 examining the plans for the fire pumps including the emergency fire pump<sup>1</sup>, if applicable, fire mains, hydrants, hoses and nozzles and the international shore connection (SOLAS 74/00 regs.II-2/10.2 and 10.4.4 and FSSC chs.2 and 12)

(EI) 1.1.1.6 checking the provision of a fixed fire detection and fire alarm system for machinery spaces including periodically unattended machinery spaces and enclosed spaces containing incinerators (SOLAS 74/00/10 regs.II-2/7.2, 7.3 and 7.4; FSSC ch.9) (SOLAS 74/88 regs.II-2/13 and 14);

---

<sup>1</sup> Refer to the unified interpretation of chapter 12 of the FSS Code, MSC.1/Circ.1388.

- (EI) 1.1.1.14 examining the plans for the special arrangements for the carriage of dangerous goods, when appropriate, including water supplies, electrical equipment and wiring, fire detection including sample extraction smoke detection systems, where applicable, ventilation, bilge pumping, personnel protection and any water spray system (SOLAS 74/00 reg.II-2/19 (except 19.3.8, 19.3.10 and 19.4); FSSC chs.9 and 10) (SOLAS 74/88 reg.II-2/54);
- (EI) 1.1.1.16 examining, where applicable, the approved documentation for the alternative design and arrangements (SOLAS 00/06 regs. II-2/17 and III/38);
- (EI) 1.1.1.17 examining the design of the survival craft, including their construction equipment, fittings, release mechanisms launching and recovery appliances and embarkation and launching arrangements (SOLAS 74/96/06/11 regs.III/ 4,16, 31, 32 to 33; LSAC sections. 3.2, 4.1 to 4.9, 6.1 and 6.2);
- (EI) 1.1.1.30 checking the plans provision and specification of for the pilot transfer arrangement, the pilot ladders, the combination arrangements, where applicable, the access to the ship's deck and the associated equipment and lighting and hoists/pilot transfer arrangements(SOLAS 74/88/10 reg.V/23);
- (EI) 1.1.2 For the examination of plans and designs of the life-saving appliances and the other equipment of cargo ships the additional requirements for oil-tankers should consist of:
- (EI) 1.1.2.1 examining the plans for the cargo tank protection (SOLAS 74/00 regs.II-2/4.5.3, 4.5.5, 4.5.6, ~~4.5.7~~ and 10.8; FSSC chs.14 and 15) (SOLAS 74/88 regs.II-2/60 and 62); and
- (EI) 1.1.2.1bis examining the plans for gas measurement in double-hull spaces and double bottom spaces, including the fitting of permanent gas sampling lines, where appropriate (SOLAS 10 req.II-2/4.5.7.2)
- (EI) 1.1.2.1ter examining, for oil tankers of 20,000 tonnes deadweight and above, the plans for the fixed hydrocarbon gas detection system for measuring hydrocarbon gas concentrations in all ballast tanks and void spaces of double-hull and double-bottom spaces adjacent to the cargo tanks, including the forepeak tank and any other tanks and spaces under the bulkhead deck adjacent to cargo tanks (SOLAS 10 req.II-2/4.5.7.3 and FSSC ch.16);
- (EI) 1.1.3.1 examining the fire pumps and fire main and the disposition of the hydrants, hoses and nozzles and the international shore connection and checking that each fire pump, including the emergency fire pump, can be operated separately so that two jets of water are produced simultaneously from different hydrants at any part of the ship whilst the required pressure is maintained in the fire main; and testing that the emergency fire pump has the required capacity, and if the emergency fire pump is the main supply of water for any fixed fire-extinguishing system, checking that that the emergency fire pump has the capacity

- for this system<sup>Error! Bookmark not defined.</sup> (SOLAS 74/00 reg.II-2/10.2; FSSC chs.2 and 12) (SOLAS 74/88 regs.II-2/4 and 19);
- (EI) 1.1.3.8 examining any fire detection and alarm system and any automatic sprinkler, fire detection and fire alarm system, and any sample extraction smoke detection system and confirming that installation tests have been satisfactorily completed (SOLAS 74/00/10 regs.II-2/7.2, 7.3, 7.4, 7.5.1, 7.5.5, 19.3.3 and 20.4; FSSC chs.9 and 10) (SOLAS 74/88 regs.II-2/11, 13, 14, 53 and 54);
- (EI) 1.1.3.11bis examining, where applicable, the alternative design and arrangements for fire safety or life-saving appliances and arrangements, in accordance with the test and inspection requirements, if any, specified in the approved documentation (SOLAS 00/06 regs. II-2/17 and III/38);
- (EI) 1.1.3.35 checking the provision of the pilot transfer arrangement, the access to the ship's deck and the associated equipment and lighting, checking the and, as appropriate, the deployment or operation of the pilot ladders and hoists/pilot transfer the combination arrangements (SOLAS 74/00/10 reg.V/23);
- (EI) 1.1.4 For the life-saving appliances and the other equipment of cargo ships for the additional requirements for oil tankers the survey during construction and after installation should consist of:
- (EI) 1.1.4.5 examining, for all tankers, the arrangements for cargo tank protection, (SOLAS 74/00/10 regs. II-2/4.5.3, 4.5.6, and 10.8; FSSC chs. 14 and 15) (SOLAS 74/88 regs II-2/60 and 62);
- (EI) 1.1.4.6 checking, for all tankers, the provision of at least one portable instrument for measuring oxygen and one for measuring flammable vapour concentrations, together with a sufficient set of spares, and suitable means for the calibration of these instruments (SOLAS 10 reg. II-2/4.5.7.1);
- (EI) 1.1.4.7 examining the arrangements for gas measurement in double-hull spaces and double bottom spaces, including the fitting of permanent gas sampling lines, where appropriate (SOLAS 10 reg. II-2/4.5.7.2)
- (EI) 1.1.4.8 examining, for oil tankers of 20,000 tonnes deadweight and above, the fixed hydrocarbon gas detection system for measuring hydrocarbon gas concentrations in all ballast tanks and void spaces of double-hull and double-bottom spaces adjacent to the cargo tanks, including the forepeak tank and any other tanks and spaces under the bulkhead deck adjacent to cargo tanks, and confirming that the installation tests have been satisfactorily completed (SOLAS 10 reg. II-2/4.5.7.3 and FSSC ch.16);
- (EI) 1.1.5.3bis confirming that, where applicable, the approved documentation for the alternative design and arrangement is on board (SOLAS 00/06 regs.II-2/17 and III/38);
- (EI) 1.1.5.9bis checking that records are provided, identifying any pilot ladders placed into service (SOLAS 10 reg.V/23.2.4);

- (EI) 1.1.5.11 checking that the International Code of Signals and an up-to-date copy of Volume III of the International Aeronautical and Maritime Search and Rescue (IAMSAR) Manual have been provided. (SOLAS 74/00/02 reg.V/21);
- (EI) 1.1.6 For the life-saving appliances and the other equipment of cargo ships, concerning the additional requirements for oil-tankers the check that the required documentation has been placed on board should consist of:
- (EI) 1.1.6.2 confirming that the operating and maintenance instructions for the fixed hydrocarbon gas detection system are provided (SOLAS 10 reg. II-2/4.5.7.3 and FSSC ch. 16),
- (EA) 1.2.1.11bis confirming when appropriate, the validity of the International Energy Efficiency Certificate (MARPOL Annex VI reg.6.4 and 6.5);
- (EA) 1.2.1.15 confirming that, where applicable, the approved documentation for the alternative design and arrangements is on board (SOLAS 00/06 regs. II-2/17 and III/38);
- (EA) 1.2.1.23bis confirming that, where applicable, a factual statement has been provided onboard by the lifeboat release and retrieval system manufacturer or one of their representatives, that confirms the successful completion of the overhaul examination of an existing lifeboat release and retrieval system found to be compliant with paragraphs 4.4.7.6.4 to 4.4.7.6.6 of the LSA Code, or, alternatively, that a statement of acceptance of the installation of a replacement release and retrieval system to an existing lifeboat is available (SOLAS 11 reg. III/1.5; LSAC section 4.4.7.6)
- (EA) 1.2.1.30 checking that the International Code of Signals and an up-to-date copy of Volume III of the International Aeronautical and Maritime Search and Rescue (IAMSAR) Manual have been provided. (SOLAS 74/00/02 reg.V/21);
- (EA) 1.2.1.30bis checking that records are maintained identifying any pilot ladders placed into service and any repair effected (SOLAS 10 reg. V/23.2.4);
- (EA) 1.2.1.32 checking that records of navigational activities and daily reporting have been maintained (SOLAS 74/00/04-03 reg.V/28);
- (EA) 1.2.2.8 examining, as far as possible, and testing, as feasible, any fire detection and alarm system and any sample extraction smoke detection system (SOLAS 74/00/10 regs.II-2/7.2, 7.3, 7.4, 7.5.1, 7.5.5, 19.3.3 and 20.4; FSSC chs.9 and 10) (SOLAS 74/88 regs.II-2/11, 13, 14, 53 and 54);
- (EA) 1.2.2.13bis examining, where applicable, the alternative design and arrangements for fire safety or life-saving appliances and arrangements, in accordance with the test, inspection and maintenance requirements, if any, specified in the approved documentation (SOLAS 00/06 regs. II-2/17 and III/38);

- (EA) 1.2.2.17 examining each survival craft, including its equipment and, when fitted, the on-load release mechanism and hydrostatic lock and, for inflatable liferafts, the hydrostatic release unit and float-free arrangements. Checking that the hand-held flares are not out of date (SOLAS 74/00 regs.III/16, 20 and 31; LSAC sections 2.5, 3.1 to 3.3, 4.1.5, 4.4.7 and 4.4.8);
- (EA) 1.2.2.35 checking the provision, and operation and the annual test has been carried out for of the automatic identification system, where fitted, and whether the annual test has been carried out and a copy of the test report is on board (SOLAS 74/00/04/10 regs.V/18.9 and 19);
- (EA) 1.2.2.37 checking the provision and specification of the pilot ladders and ~~hoists~~/pilot transfer arrangements (SOLAS 74/00/10 reg.V/23);
- (EA) 1.2.3 For the life-saving appliances and the other equipment of cargo ships, concerning the additional requirements for ~~oil~~-tankers the annual survey should consist of:
- (EA) 1.2.3.4bis checking for all tankers, the provision of at least one portable instrument for measuring oxygen and one for measuring flammable vapour concentrations, together with a sufficient set of spares, and suitable means for the calibration of these instruments (SOLAS 10 reg. II-2/4.5.7.1);
- (EA) 1.2.3.4ter examining the arrangements for gas measurement in double-hull spaces and double bottom spaces, including the fitting of permanent gas sampling lines, where appropriate (SOLAS 10 reg. II-2/4.5.7.2)
- (EA) 1.2.3.4quad examining, as far as possible and testing the fixed hydrocarbon gas detection system (SOLAS 10 reg. II-2/4.5.7.3 and FSSC ch. 16);
- (EP) 1.3.2.4 testing any fire detection and alarm system and any sample extraction smoke detection system (SOLAS 74/00/10 regs.II-2/7.2, 7.3, 7.4, 7.5.5, 19.3.3 and 20.4; FSSC chs.9 and 10) (SOLAS 74/88 regs.II-2/11, 13, 14, 53 and 54);
- (EP) 1.3.3 for the life-saving appliances and the other equipment for the additional requirements for ~~oil~~-tankers the periodical survey should consist of:
- (ER) 1.4.3 for the life-saving appliances and the other equipment of cargo ships, concerning the additional requirements for ~~oil~~-tankers the renewal survey should consist of:

4 Amendments to annex 1 – Survey Guidelines under the 1974 SOLAS Convention as modified by the 1988 Protocol relating thereto – (C) 2 Guidelines for Surveys for the Cargo Ship Safety Construction Certificate:

- (CI) 2.1.1.1bis examining plans to verify that bulk carriers of 150 m in length and above, where appropriate, meet the applicable structural requirements of an organization recognized by the Administration, or national standards of the Administration, conforming to the functional requirements of the Goal-based Ship Construction Standards for Bulk Carriers and Oil Tankers (SOLAS 10 reg. II-1/3-10);

- (CI) 2.1.1.6 examining, where applicable, the approved documentation for the alternative design and arrangements (SOLAS 00/06 regs.II-1/55 and II-2/17);
- (CI) 2.1.2.8 examining plans to verify that oil tankers of 150 m in length and above, where appropriate, meet the applicable structural requirements of an organization recognized by the Administration, conforming to the functional requirements of the Goal-based Ship Construction Standards for Bulk Carriers and Oil Tankers (SOLAS 10 reg.II-1/3-10);
- (CI) 2.1.3.1bis confirming in accordance with the survey plan, that bulk carriers of 150 m in length and above, where appropriate, meet the applicable structural requirements of an organization recognized by the Administration, or national standards of the Administration, conforming to the functional requirements of the Goal-based Ship Construction Standards for Bulk Carriers and Oil Tankers (SOLAS 10 reg. II-1/3.10);
- (CI) 2.1.3.17 confirming and recording the ability of the machinery to reverse the direction of the thrust of the propeller in sufficient time and to bring the ship to rest within a reasonable distance, including the effectiveness of any supplementary means of manoeuvring or stopping the ship<sup>2</sup> (SOLAS 74/88 reg.II-1/28);
- (CI) 2.1.3.18 confirming that the main and auxiliary steering gear are so arranged that the failure of one of them does not render the other inoperative<sup>3</sup> (SOLAS 74/88 reg.II-1/29);
- (CI) 2.1.3.21 confirming that the main steering gear is capable of steering the ship at maximum ahead service speed and is capable of putting the rudder over from 35° on one side to 35° on the other side with the ship at its deepest seagoing draught<sup>3</sup> and running ahead at maximum ahead service speed and, under the same conditions, from 35° on either side to 30° on the other side in not more than 28s<sup>Error! Bookmark not defined.</sup> (SOLAS 74/88 reg.II-1/29);
- (CI) 2.1.3.22 confirming that the auxiliary steering gear is capable of steering the ship at navigable speed and of being brought speedily into action in an emergency and that it is capable of putting the rudder over from 15° on one side to 15° on the other side in not more than 60 s with the ship at its deepest seagoing draught and running ahead at one half of the maximum ahead service speed or 7 knots, whichever is the greater<sup>Error! Bookmark not defined.</sup> (SOLAS 74/88 reg.II-1/29);
- (CI) 2.1.3.24 confirming that, where the main steering gear comprises two or more identical power units and an auxiliary steering gear is not fitted, a defect can be isolated so that steering capability can be maintained or speedily regained after a single failure in its piping system or in one of the power units<sup>Error! Bookmark not defined.</sup> (SOLAS 74/88 reg.II-1/29);

---

<sup>2</sup> For ships fitted with alternative propulsion and steering arrangements other than traditional arrangement, such as but not limited to, azimuthing propulsors or water jet propulsion systems, refer to MSC.1/Circ.1416.

<sup>3</sup> For trials with the ship not at the deepest sea going draught, refer to MSC.1/Circ.1425.



- 
- (CI) 2.1.3.53bis examining, where applicable, the alternative design and arrangements for machinery or electrical installations, or fire safety, in accordance with the test and inspection requirements, if any, specified in the approved documentation (SOLAS 00/06 regs. II-1/55 and II-2/17);
- (CI) 2.1.3.60 confirming that installed materials do not contain asbestos<sup>4</sup> (SOLAS 74/00/09 reg.II-1/3-5);
- (CI) 2.1.3.62bis prior to the review of the coating technical file:
- (CI) 2.1.3.62bis.1 checking that the Technical Data Sheet and Statement of Compliance or Type Approval Certificate comply with the Standard;
- (CI) 2.1.3.62bis.2 checking that the coating identification on representative containers is consistent with the coating identified in the Technical Data Sheet;
- (CI) 2.1.3.62bis.3 checking that the inspector is qualified in accordance with the qualification standards;
- (CI) 2.1.3.62bis.4 checking that the inspector's reports of surface preparation and the coating's application indicate compliance with the manufacturer's Technical Data Sheet and Statement of Compliance or Type Approval Certificate; and
- (CI) 2.1.3.62bis.5 monitoring the implementation of the coating inspection requirements.
- (CI) 2.1.3.62ter reviewing the Coating Technical File (SOLAS 74/00/06/10 regs. II-1/3-2 and II-1/3-11; MSC.215(87) and MSC.288(87));
- (CI) 2.1.3.63 confirming for oil tankers and bulk carriers, when appropriate, the provision of means of access to cargo and other spaces in accordance with the arrangements in the Ship Structures Access Manual (SOLAS 74/00/02/04 reg. II-1/3-6, SOLAS 10 regs. II-1/3-10 and MSC.287(87));
- (CI) 2.1.4.1bis confirming in accordance with the survey plan, that oil tankers of 150 m in length and above, where appropriate, meet the applicable structural requirements of an organization recognized by the Administration, or national standards of the Administration, conforming to the functional requirements of the Goal-based Ship Construction Standards for Bulk Carriers and Oil Tankers (SOLAS 10 reg. II-1/3-10);
- (CI) 2.1.4.9 confirming that all cargo oil tanks in crude oil tankers have either:
- (CI) 2.1.4.9.1 been coated in accordance with MSC.288(87); or
- (CI) 2.1.4.9.2 been protected by alternative means of corrosion protection or utilization of approved corrosion resistance material (steel) in accordance with MSC.289(87) (SOLAS 10 reg. II-1/3-11).

---

<sup>4</sup> Guidance on the means to verify that installed materials do not contain asbestos is contained in MSC.1/Circ.1426 on Unified interpretation on the implementation of SOLAS regulation II-1/3-5 and MSC.1/Circ.1379.

- (CI) 2.1.5.1 the provisions of (CI) 2.1.4 except (CI) 2.1.4.1 bis.
- (CI) 2.1.6.1 confirming that the stability information and the damage control plans and damage control booklets have been provided (SOLAS 74/88 regs.II-1/22 and 23-1) (SOLAS 06 regs.II-1/5-1 and 19);
- (CI) 2.1.6.3 confirming that the approved Cargo Securing Manual for ships carrying cargo units including containers is provided on board (SOLAS 74/94 98 reg.VI/5.6);
- (CI) 2.1.6.6 confirming when appropriate that a coating technical file reviewed by the Administration has been provided on board (SOLAS 74/00/06/10 regs.II-1/3-2 and 3-11);
- (CI) 2.1.6.7 bis confirming, for oil tankers and bulk carriers of 150 m in length and above, that the Ship Construction File has been provided (SOLAS 10 reg. II-1/3-10 and MSC.290(87));
- (CI) 2.1.6.7 ter confirming, when appropriate, that a technical file verified by the Administration has been provided on board (SOLAS 10 reg. II-1/3-11 and MSC.289(87));
- (CA) 2.2.1.11 bis confirming when appropriate, the validity of the International Energy Efficiency Certificate (MARPOL Annex VI regs.6.4 and 6.5);
- (CA) 2.2.1.17 confirming that the stability information, including damage stability, where applicable, and the damage control plans and damage control booklets are on board (SOLAS 74/88 regs.II-1/22, 23 and 25) (SOLAS 06 reg.II-1/5-1 and 19);
- (CA) 2.2.1.26 confirming approved Cargo Securing Manual for ships carrying cargo units including containers is on board (SOLAS 74/94 98 reg.VI/5.6);
- (CA) 2.2.1.30 confirming when appropriate that the coating technical file is available on board and maintained (SOLAS 74/00/06/10 regs.II-1/3-2 and 3-11);
- (CA) 2.2.1.31 bis confirming, where appropriate, for crude oil tankers, that a technical file verified by the Administration has been provided on board (SOLAS 10 reg.II-1/3-11 and MSC.289(87));
- (CA) 2.2.1.31 ter confirming, for oil tankers and bulk carriers of 150 m in length and above, that the Ship Construction File is available (SOLAS 10 reg. II-1/3-10 and MSC.287(87));
- (CA) 2.2.2.2 bis examining, for bulk carriers of 150 m and above, where appropriate, the ship's structure in accordance with the Ship Construction File, taking into account identified areas that need special attention (SOLAS 10 reg. II-1/3-10 and MSC.287(87));
- (CA) 2.2.2.24 bis examining, where applicable, the alternative design and arrangements for machinery or electrical installations, or fire safety, in accordance with the test, inspection and maintenance requirements, if any, specified in the approved documentation (SOLAS 00/06 regs.II-1/55 and II-2/17);

(CA) 2.2.2.30 confirming that no new materials containing asbestos were installed on board<sup>4</sup> (SOLAS 74/00/04/09 reg.II-1/3-5);

(CA) 2.2.3.15bis confirming that the coating system in cargo oil tanks of crude oil tankers, when appropriate, is maintained and that in-service maintenance and repair activities are recorded in the coating technical file (SOLAS 10 reg. II-1/3-11 and MSC.288(87));

(CA) 2.2.3.17 examining, for oil tankers of 150 m in length and above, where appropriate, the ship's structure in accordance with the Ship Construction File, taking into account identified areas that need special attention (SOLAS reg. II-1/3-10 and MSC.287(87));

(CA) 2.2.4.1 the provisions of (CA) 2.2.3 except (CA) 2.2.3.15bis and (CA) 2.2.3.17.

(CIn) 2.3.4.1 the provisions of (CA) 2.2.3 except (CA) 2.2.3.15bis and (CA) 2.2.3.17.

(CR) 2.4.4.1 the provisions of (CA) 2.2.3 except (CA) 2.2.3.15bis and (CA) 2.2.3.17.

5 Amendments to annex 1 – Survey Guidelines under the 1974 SOLAS Convention as modified by the 1988 Protocol relating thereto – (R) 4 Guidelines for Surveys for the Cargo Ship Safety Radio Certificate:

(RI) 4.1.2.16.4 checking that the unique beacon identification code EPIRB ID is clearly marked on the outside of the equipment and, where possible, decoding the unique beacon identification code EPIRB identity number confirming it is correct;

(RI) 4.1.2.16.4bis checking that the unique beacon identification code programmed in the EPIRB corresponds with the unique beacon identification code assigned by or on behalf of the Administration;

(RI) 4.1.2.16.4ter checking that the MMSI number if encoded in the beacon corresponds with the MMSI number assigned to the ship;

(RP) 4.2.1.11bis confirming when appropriate, the validity of the International Energy Efficiency Certificate (MARPOL Annex VI regs 6.4 and 6.5);

6 Amendments to annex 1 – Survey Guidelines under the 1974 SOLAS Convention as modified by the 1988 Protocol relating thereto – (P) 5 Guidelines for Surveys for the Passenger Ship Safety Certificate:

(PI) 5.1.1.12 examining the plans for the fire pumps, including the emergency fire pump<sup>Error! Bookmark not defined.</sup> if applicable, fire mains, hydrants, hoses and nozzles and the international shore connection (SOLAS 74/88 reg.II-1/39 and SOLAS 74/00 reg.II-2/10.2; FSSC chs.2 and 12) (SOLAS 74/88 reg.II-1/39 and regs.II-2/4 and 19);

(PI) 5.1.1.19 examining the plans for the protection of special category spaces and other cargo spaces (SOLAS 74/88 regs.II-2/37, 38 and 39) (SOLAS 74/00/06/10 regs.II-2/ 7.6, 9 and 20; FSSC chs. 9 and 10);

- (PI) 5.1.1.20 examining the plans for the fixed fire detection and alarm system, the crew alarm and the public address system or other effective means of communication, and any automatic sprinkler, fire detection and fire alarm system, as applicable, in machinery spaces, including enclosed spaces containing incinerators, accommodation and service spaces and control spaces (SOLAS 74/00/06/10 reg. II-2/7 (except 7.5.5, 7.6 and 7.9); FSSC chs. 8, 9 and 10) (SOLAS 74/88 reg.II-2/40) (SOLAS 74/00/06 regs.II-2/7 and 12) (SOLAS 74/88 reg.II-2/40);
- ~~(PI) 5.1.1.20bis examining the plans for the crew alarm and the public address system or other effective means of communication (SOLAS 74/00/06 regs.II-2/7.9; FSSC ch. 9; LSAC ch.7) (SOLAS 74/88 reg.II-2/40);~~
- (PI) 5.1.1.21 examining the plans for the special arrangements for the carriage of dangerous goods, when appropriate, including water supplies, electrical equipment and wiring, fire detection sample extraction smoke detection system, bilge pumping and personnel protection (SOLAS 74/88 regs.II-2/41 and 54) (SOLAS 74/00/08 reg.II-2/19; FSSC chs. 9 and 10);
- (PI) 5.1.1.23 examining the design of the survival craft, including their construction, equipment, fittings, release mechanisms launching and recovery appliances and embarkation and launching arrangements (SOLAS 74/88/06 regs.III/4, 20 to 24, 36, 38 to 44 and 48) (SOLAS 06 reg.III/4) (LSAC sections 3.2, 4.1 to 4.6, 6.1 to 6.2);
- (PI) 5.1.1.35 checking the plans provision and specification of the pilot transfer arrangement, the pilot ladders, the combination arrangements, where applicable, the access to the ship's deck and the associated equipment and lighting and hoists/pilot transfer arrangements (SOLAS 74/00/10 reg.V/23);
- (PI) 5.1.2.12 confirming the arrangements for closing sidescuttles and their deadlights, also scuppers, sanitary discharges and similar openings and other inlets and discharges in the shell plating below the bulkhead deck (SOLAS 06 reg.II-1/13-15);
- (PI) 5.1.2.30 confirming and recording the ability of the machinery to reverse the direction of the thrust of the propeller in sufficient time and to bring the ship to rest within a reasonable distance, including the effectiveness of any supplementary means of manoeuvring or stopping the ship<sup>Error!</sup>  
Bookmark not defined. (SOLAS 74/88 reg.II-1/28);
- (PI) 5.1.2.31 confirming that the main and auxiliary steering gear are so arranged that the failure of one of them does not render the other inoperative<sup>Error!</sup>  
Bookmark not defined. (SOLAS 74/88 reg.II-1/29);
- (PI) 5.1.2.34 confirming that the main steering gear is capable of steering the ship at maximum ahead service speed and is capable of putting the rudder over from 35 degrees on one side to 35 degrees on the other side with the ship at its deepest seagoing draught<sup>3</sup> and running ahead at maximum ahead service speed and, under the same conditions, from 35 degrees on either side to 30 degrees on the other side in not more than 28 seconds<sup>Error!</sup> Bookmark not defined. (SOLAS 74/88 reg.II-1/29);

- (PI) 5.1.2.35 confirming that the auxiliary steering gear is capable of steering the ship at navigable speed and of being brought speedily into action in an emergency and that it is capable of putting the rudder over from 15 degrees on one side to 15 degrees on the other side in not more than 60 seconds with the ship at its deepest seagoing draught and running ahead at one half of the maximum ahead service speed or 7 knots, whichever is the greater<sup>Error! Bookmark not defined.</sup> (SOLAS 74/88 reg.II-1/29);
- (PI) 5.1.2.37 confirming that, where the main steering gear comprises two or more identical power units and an auxiliary steering gear is not fitted, a defect can be isolated so that steering capability can be maintained or speedily regained after a single failure in its piping system or in one of the power units<sup>Error! Bookmark not defined.</sup> (SOLAS 74/88 reg.II-1/29)
- (PI) 5.1.2.65.1 for passenger ships, constructed on or after 1 July 2010<sup>10</sup>, confirming provision of supplementary lighting in all cabins, and checking that such lighting automatically illuminates and remains on for a minimum of 30 min when power to the normal cabin lighting is lost (SOLAS 06/10 reg.II-1/41.6);
- <sup>10</sup> Refer to Guidance for application of SOLAS II-1/41.6 (MSC.1/Circ.1372)
- (PI) 5.1.2.67bis examining, where applicable, the alternative design and arrangements for machinery or electrical installations, fire safety, or life-saving appliances and arrangements, in accordance with the test and inspection requirements, if any, specified in the approved documentation (SOLAS 00/06 regs.II-1/55, II-2/17 and III/38);
- (PI) 5.1.2.68 examining the fire pumps and fire main and the disposition of the hydrants, hoses and nozzles and the international shore connection and checking that each fire pump, including the emergency fire pump, can be operated separately so that two jets of water are produced simultaneously from different hydrants at any part of the ship whilst the required pressure is maintained in the fire main and testing that the emergency fire pump, if applicable, has the required capacity, and if the emergency fire pump is the main supply of water for any fixed fire-extinguishing system, checking that the emergency fire pump has the capacity for this system<sup>Error! Bookmark not defined.</sup> (SOLAS 74/88 regs.II-2/4 and 19, FSSC chs. 2 and 12);
- (PI) 5.1.2.83 confirming the fire protection arrangements, including fire detection and sample extraction smoke detection systems for special category spaces and other cargo spaces for cargo and dangerous goods and testing, as appropriate, the operation of the means for closing the various openings (SOLAS 74/88 regs.II-2/37, ~~38~~ and ~~39~~) (SOLAS 74/00 regs.II-2/7.6 and 10.7; FSSC chs. 5, 9 and 10);
- (PI) 5.1.2.83bis confirming the fire protection arrangements, including fire detection and sample extraction smoke detection systems, where applicable for vehicle, special category and ro-ro spaces and testing, as appropriate, the operation of the means for closing the various openings (SOLAS 74/88 regs.II-2/37, and 38) (SOLAS 74/00 reg.II-2/20 (except 20.5); FSSC chs. 5, 6, 7, 9, 10);

- (PI) 5.1.2.84 confirming and testing, as appropriate, the ~~any~~ fixed fire detection and alarm system, the ~~special alarm and the public address system or other effective means of communication and any automatic sprinkler, fire detection and fire alarm system, as applicable, in machinery spaces, including enclosed spaces containing incinerators, accommodation, service and control spaces (SOLAS 74/88 reg.II-2/40) (SOLAS 74/00/06/10 regs II-2/7 (except 7.5.5, 7.6 and 7.9); FSSC chs. 8 and 9) (SOLAS 74/88 reg.II-2/40)(SOLAS 74/00/06 regs.II-2/7 and 12);;~~
- ~~(PI) 5.1.2.84bis~~ confirming and testing the special alarm and the public address system or other effective means of communication (SOLAS 74/88 reg.II-2/40) (SOLAS 74/00/06/10 reg.II-2/12; LSAC ch. 7);
- (PI) 5.1.2.86 examining, when appropriate, the special arrangements for carrying dangerous goods, including checking the electrical equipment and wiring, fire detection, ventilation and boundary insulation, the provision of protective clothing and portable appliances and the testing of the water supply, bilge pumping and any water spray system (SOLAS 74/88 regs.II-2/41 and 54) (SOLAS 74/00/08 reg.II-2/19);
- (PI) 5.1.2.88 examining each survival craft, including its equipment, and that the required number of search and rescue locating devices are fitted in liferafts and those liferafts are clearly marked (SOLAS 74/88/00/02/08 regs.III/20, 21 and 26; LSAC sections 2.3 to 2.5, 3.2 and 4.1 to 4.6);
- (PI) 5.1.2.90 deployment of 50% of the MES after installation (~~LSAC section 5.1 and MSC/Circ.809~~ LSAC paragraph 6.2.2.2);
- (PI) 5.1.2.102 checking that a decision support system is provided for the Master (SOLAS 74/00 reg.III/29; SOLAS 06 regs. II-2/21 and 22);
- (PI) 5.1.2.109 checking that the International Code of Signals and an up-to-date copy of Volume III of the International Aeronautical and Maritime Search and Rescue (IAMSAR) Manual have been provided. (SOLAS 74/00/02 reg.V/21);
- (PI) 5.1.2.110 checking the provision of the pilot transfer arrangement, the access to the ship's deck and the associated equipment and lighting, checking the and, as appropriate, the deployment or operation of the pilot ladders and hoists/pilot transfer combination arrangements, where applicable (SOLAS 74/00/10 reg.V/23);
- (PI) 5.1.2.126.4 checking that the unique beacon identification code EPIRB ID is clearly marked on the outside of the equipment and, where possible, decoding the unique beacon identification code EPIRB identity number confirming it is correct;
- ~~(PI) 5.1.2.126.4bis~~ checking that the unique beacon identification code programmed in the EPIRB corresponds with the unique beacon identification code assigned by or on behalf of the Administration;
- ~~(PI) 5.1.2.126.4ter~~ checking that the MMSI number if encoded in the beacon corresponds with the MMSI number assigned to the ship;

- 
- (PI) 5.1.2.135 ~~checking that the provision, and, operation and the annual test has been carried out for of~~ the automatic identification system (SOLAS 74/00/04 reg.V/19);
- (PI) 5.1.2.137 confirming that installed materials do not contain asbestos<sup>4</sup> (SOLAS 09 reg.II-1/3-5);
- (PI) 5.1.3.1 confirming that the stability information and damage control plans and damage control booklets have been provided (SOLAS 74/88 regs.II-1/22 and 23) (SOLAS 06 regs.II-1/5-1 and 19);
- (PI) 5.1.3.10 confirming that emergency instructions are available for each person on board, that the muster list is posted in conspicuous places, and that they are in a language understood by the persons on board (SOLAS 74/00 regs.III/8 and ~~53~~ 37);
- (PI) 5.1.3.16bis checking that records are provided, identifying any pilot ladders placed into service (SOLAS 10 reg.V/23.2.4);
- (PR) 5.2.1.8bis confirming when appropriate, the validity of the International Energy Efficiency Certificate (MARPOL Annex VI regs. 6.4 and 6.5);
- (PR) 5.2.1.17 confirming that the stability information and damage control plans and damage control booklets are readily available (SOLAS 74/88 regs.II-1/22 and 23) (SOLAS 06 regs.II-1/5-1 and 19);
- (PR) 5.2.1.27bis confirming that, if applicable, a factual statement issued by the manufacturer of the lifeboat release mechanism is available, confirming the successful overhaul examination of a mechanism compliant with paragraphs 4.4.7.6.4 to 4.4.7.6.6 of the LSA Code, or, alternatively, that a statement of acceptance of the installation of a replacement release and retrieval system to an existing lifeboat is available (SOLAS 11 reg.III/1.5; LSAC section 4.4.7.6);
- (PR) 5.2.1.35bis checking that records are maintained identifying any pilot ladders placed into service and any repair effected (SOLAS 10 reg.V/23.2.4);
- (PR) 5.2.1.38 confirming the provisions of (PI) 5.1.3.14 to (PI) 5.1.3.19 except (PI) 5.1.3.16bis;
- (PR) 5.2.2.31 confirming that the main and auxiliary steering gear are being properly maintained, are arranged so that the failure of one does not render the other inoperative and that the auxiliary steering gear is capable of being brought speedily into action in an emergency<sup>Error! Bookmark not defined.</sup> (SOLAS 74/88 reg.II-1/29);
- (PR) 5.2.2.62bis examining, where applicable, the alternative design and arrangements for machinery or electrical installations, fire safety, or life-saving appliances and arrangements, in accordance with the test, inspection and maintenance requirements, if any, specified in the approved documentation (SOLAS 00/06 regs.II-1/55, II-2/17 and III/38);
- (PR) 5.2.2.72 examining and testing, as far as practicable, any fire detection and fire alarm arrangements in machinery spaces, including enclosed spaces

- containing incinerators, if applicable, accommodation and service spaces and control spaces (SOLAS 74/00/10 reg.II-2/7 (except 7.5.5, 7.6 and 7.9); FSSC chs. 8 and 9) (SOLAS 74/88 regs.II-2/11, 12, 13, 13-1, 14, 36 and 41);
- (PR) 5.2.2.82 examining the fire-extinguishing arrangements, examining and testing the fire detection and alarm systems, the sample extraction smoke detection systems, where applicable including fire detection in cargo spaces for general cargo and dangerous goods and testing, as far as practicable and as appropriate, the operation of the means for closing the various openings (SOLAS 74/00 regs.II-2/7.6 and 10.7; FSSC chs.5, 9 and 10) (SOLAS 74/88 reg.II-2/39);
- (PR) 5.2.2.83 examining the fire-extinguishing arrangements including fire detection examining and testing the fire detection and alarm system, the sample extraction smoke detection system, where applicable, in vehicle, special category and ro-ro spaces and testing, as far as practicable and as appropriate, the operation of the means for closing the various openings (SOLAS 74/00 reg.II-2/20 (except 20.5); FSSC chs.5, 6, 7, 9 and 10) (SOLAS 74/88 regs.II-2/37, 38 and 38-1);
- (PR) 5.2.2.85 examining, when appropriate, the special arrangements for carrying dangerous goods, including checking the electrical equipment and wiring, fire detection, ventilation, the provision of personnel protection clothing and portable appliances, testing any fire detection and alarm system and any sample extraction smoke detection system and testing, as far as practicable, the water supply, bilge pumping and any water spray system (SOLAS 74/00/08 reg.II-2/19 (except 19.3.8, 19.3.10 and 19.4); FSSC chs.3, 4, 7, 9 and 10) (SOLAS 74/88 regs.II-2/41 and 54);
- (PR) 5.2.2.92 examining each survival craft, including its equipment and, when fitted, the on-load release mechanism and hydrostatic lock, and for inflatable liferafts the hydrostatic release unit and float free arrangements, including the date of servicing or replacement. Checking that the hand-flares are not out of date and that the required number of search and rescue locating devices are fitted in liferafts and those liferafts are clearly marked (SOLAS 74/96/00/02/08 regs.III/20, 21, 23, 24 and 26; LSAC sections 2.3 to 2.5, 3.2 and 4.1 to 4.6);
- (PR) 5.2.2.101 confirming that a decision support system is provided for the Master (SOLAS 74/88 reg.III/29) (SOLAS 06 regs. II-2/21 and 22);
- (PR) 5.2.2.111 checking that the International Code of Signals and an up-to-date copy of Volume III of the International Aeronautical and Maritime Search and Rescue (IAMSAR) Manual have been provided. (SOLAS 74/00/02 reg.V/21);
- (PR) 5.2.2.113 checking the provision, and operation of and that the annual test has been carried out for the automatic identification system, where fitted, and whether the annual test has been carried out and a copy of the test report is on board (SOLAS 74/00/04/10 regs.V/18.9 and 19);
- (PR) 5.2.2.114 checking the provision and specification of the pilot ladders and hoists/pilot transfer arrangements (SOLAS 74/00/10 reg.V/17.23);



(PR) 5.2.2.116 confirming that no new materials containing asbestos were installed on board (SOLAS 74/00/05/09 reg.II-1/3-5)<sup>4</sup>

7 Amendments to annex 2 – Survey Guidelines under the 1966 Load Line Convention as modified by the 1988 Protocol relating thereto – (L) 1 Guidelines for surveys for the International Load Line Certificate or International Load Line Exemption Certificate:

(LI) 1.1.2.14 examining the special requirements for ships permitted to sail with type "A" or type "B-minus" freeboards (LLC 66/88/03 regs.26 and 27);

(LA) 1.2.1.11bis confirming when appropriate, the validity of the International Energy Efficiency Certificate (MARPOL Annex VI, regs. 6.4 and 6.5)

8 Amendments to annex 3 – Survey Guidelines under the MARPOL Convention – (O) 1 Guidelines for Surveys for the International Oil Pollution Prevention Certificate:

(OI) 1.1.2.11 examining, for oil tanker of 5,000 tonnes deadweight and above delivered on or after 1 February 2002, the intact stability (MARPOL 90/04 Annex I reg.27);

(OA) 1.2.1.9bis confirming when appropriate, the validity of the International Energy Efficiency Certificate (MARPOL Annex VI, regs. 6.4 and 6.5);

9 Amendments to annex 3 – Survey Guidelines under the MARPOL Convention – (N) 2 Guidelines for Surveys for the International Pollution Prevention Certificate for the Carriage of Noxious Liquid Substances in Bulk:

(NI) 2.1.2.10 confirming if applicable the construction and arrangements of a ship certified to carry individually identified vegetable oils under exemption from the carriage requirements (MARPOL 90/04 Annex II reg.4.3 4.1.3).

(NI) 2.1.3.3 confirming that the shipboard marine pollution emergency plan is provided (MARPOL ~~90/04~~ Annex II reg.17).

(NA) 2.2.1.7bis confirming when appropriate, the validity of the International Energy Efficiency Certificate (MARPOL Annex VI, regs. 6.4 and 6.5);

10 Amendments to annex 3 – Survey Guidelines under the MARPOL Convention – (S) 3 Guidelines for Surveys for the International Sewage Pollution Prevention Certificate:

(SI) 3.1.1.2 if a sewage treatment plant is fitted, checking that it is type approved by the Administration in accordance with the appropriate resolution (MARPOL Annex IV regs.9.1.1 and 9.2.1);

(SI) 3.1.1.3 if a sewage comminuting and disinfecting system is fitted, checking that it is approved by the Administration and that facilities for the temporary storage of sewage are provided (MARPOL Annex IV reg.9.1.2);

(SI) 3.1.1.4 if a sewage holding tank is fitted, checking its capacity having regard to the number of persons on board (MARPOL Annex IV regs.9.1.3 and 9.2.2);

- (SI) 3.1.2.1 checking externally, as applicable, the sewage treatment plant or the sewage comminuting and disinfecting system, and confirming their operation (MARPOL Annex IV regs.4.1.1 and 9.1.1, 9.1.2 and 9.2.1);
- (SI) 3.1.2.2 if a sewage holding tank is fitted, checking that it has been constructed in a satisfactory manner, and checking that the holding tank has a means to indicate visually the amount of its contents (MARPOL Annex IV regs.9.1.3 and 9.2.2);
- (SR) 3.2.1.4bis confirming when appropriate, the validity of the International Energy Efficiency Certificate (MARPOL Annex VI regs. 6.4 and 6.5);
- (SR) 3.2.2.2 examining externally the sewage pollution prevention system and confirming, as far as practicable its satisfactory operation (MARPOL Annex IV, reg.9);
- (SR) 3.2.2.4 confirming, for ships where a sewage holding tank is fitted as a sewage system, that an approval for the rate of discharge is available (MARPOL IV, regs. 9.1.3 and 11.1.1)

11 Amendments to annex 3 – Survey Guidelines under the MARPOL Convention – (A)  
4 Guidelines for Surveys for the International Air Pollution Prevention Certificate and the NO<sub>x</sub> Technical Code:

- (AI) 4.1.2.2.1.4 for marine diesel engines of an output more than 5,000 kW and a per cylinder displacement at or above 90 litres/cylinder installed on ships constructed between 1 January 1990 and 31 December 1999, check whether:

- .1 an approved method exists;
- .2 an approved method is not commercially available; or
- .3 that an approved method is installed and where this is the case, that there is an approved method file,

and apply the verification procedures as given in the approved method file;

- .4 or that the engine has been certified, confirming that it operates within the limits set forth for Tier I, Tier II or Tier III (MARPOL Annex VI, req. 13.7.3);

- (AI) 4.1.2.3.1 confirming, if appropriate, that:
- .1 satisfactory arrangements are in place for using compliant fuel as required; or
  - .2 satisfactory installation and operation of the fuel switching arrangements are in place when tanks are provided for different grades of fuel, and that a written procedure showing how the fuel oil changeover is done, is available; or

---

(AA) 4.2.1.4**bis** checking when appropriate, the validity of the International Pollution Prevention Certificate for the Carriage of Noxious Liquid Substances in Bulk;

(AA) 4.2.1.4**ter** checking when appropriate, the validity of the International Sewage Pollution Prevention Certificate;

(AA) 4.2.1.4**quad** confirming when appropriate, the validity of the International Energy Efficiency Certificate (MARPOL Annex VI, regs. 6.4 and 6.5)

(AA) 4.2.2.4.6 for a marine diesel engine with an output of more than 5,000 kW and a per cylinder displacement at or above 90 litres/cylinder installed on ships constructed between 1 January 1990 and 31 December 1999, check whether:

- .1 an approved method exists;
- .2 an approved method is not commercially available; or
- .3 that an approved method is installed and where this is the case, that there is an approved method file,

and apply the verification procedures as given in the approved method file;

- .4 or that the engine has been certified, confirming that it operates within the limits set forth for Tier I, Tier II or Tier III (MARPOL Annex VI reg. 13.7.3);

(AR) 4.4.2.2.1 confirming, if necessary by simulated test or equivalent, the satisfactory operation of the ~~following~~ alarms and safety devices.

12 Amendments to annex 4 – Survey Guidelines under mandatory Codes – *Guidelines for Surveys for the International Certificate of Fitness for the Carriage of Dangerous Chemicals in Bulk* and the Certificate of Fitness for the Carriage of Dangerous Chemicals in Bulk:

(DA) 1.2.1.9**bis** confirming when appropriate, the validity of the International Energy Efficiency Certificate (MARPOL Annex VI, regs. 6.4 and 6.5);

(DA) 1.2.1.20 confirming that the Shipboard marine pollution emergency plan is on board (MARPOL ~~73/78/02~~ 04 Annex II reg. ~~46-17~~);

(DA) 1.2.1.21 confirming that the Cargo Record Book is on board and being correctly used (MARPOL ~~73/78/91/97/02~~ 04 Annex II reg. ~~9~~ 15);

13 Amendments to annex 4 – Survey Guidelines under mandatory Codes – *Guidelines for Surveys for the International Certificate of Fitness for the Carriage of Liquefied Gases in Bulk*:

(GA) 2.2.1.9**bis** confirming when appropriate, the validity of the International Energy Efficiency Certificate (MARPOL Annex VI, regs. 6.4 and 6.5.);

14 Amendments to appendix 1 Summary of Amendments to Mandatory Instruments reflected in the Survey Guidelines under the HSSC:

SOLAS 1974 up to and including the ~~2009~~— 2011 amendments, (resolution ~~MSC.282(86)~~ 317(89))

SOLAS PROT 1988 up to and including the ~~2009~~—2010 amendments (resolution ~~MSC.283(86)~~309(88))

MARPOL up to and including the ~~2010~~—2012 amendments (resolution ~~MEPC.490(60)~~217(63) )

NO<sub>x</sub> Technical Code up to and including the ~~2008~~—2012 amendments (resolution ~~MEPC.477(58)~~217(63))

\*\*\*

## ANNEX 29

### DRAFT ASSEMBLY RESOLUTION

#### 2013 NON-EXHAUSTIVE LIST OF OBLIGATIONS UNDER INSTRUMENTS RELEVANT TO THE IMO INSTRUMENTS IMPLEMENTATION CODE

THE ASSEMBLY,

RECALLING Article 15(j) of the Convention on the International Maritime Organization concerning the functions of the Assembly in relation to regulations and guidelines regarding maritime safety and the prevention and control of marine pollution from ships,

RECALLING ALSO that, by resolution A.1054(27), it adopted the *Code for the Implementation of Mandatory IMO Instruments, 2011*, annexes to which, provide a non-exhaustive list of instruments and obligations for guidance on the implementation and enforcement of IMO instruments, in particular concerning the identification of the auditable areas relevant to Voluntary IMO Member State Audit Scheme,

RECOGNIZING the need for the annexes to above-mentioned Code to be further revised to take account of the amendments to the IMO instruments referred to in the Code which have entered into force or become effective since the adoption of resolution A.1054(27),

RECOGNIZING FURTHER that parties to the relevant international conventions have, as part of the ratification process, accepted to fully meet their responsibilities and to discharge their obligations under the conventions and other instruments to which they are party,

REAFFIRMING that States have the primary responsibility to have in place an adequate and effective system to exercise control over ships entitled to fly their flag, and to ensure that they comply with relevant international rules and regulations in respect of maritime safety, security and protection of the marine environment,

REAFFIRMING FURTHER that States, in their capacity as flag, port and coastal States, have other obligations and responsibilities under applicable international law in respect of maritime safety, security and protection of the marine environment,

NOTING that, while States may realize certain benefits by becoming party to instruments aiming at promoting maritime safety, security and protection of the marine environment, these benefits can only be fully realized when all parties carry out their obligations as required by the instruments concerned,

NOTING ALSO that the ultimate effectiveness of any instrument depends, inter alia, upon all States:

- (a) becoming party to all instruments related to maritime safety, security and pollution prevention and control;
- (b) implementing and enforcing such instruments fully and effectively;
- (c) reporting to the Organization, as required,

NOTING ALSO resolution [A...(28)] by which it adopted the IMO Instruments Implementation Code (III Code) [revoking resolution A.1054(27) on the Code for the Implementation of Mandatory IMO Instruments, 2011],

NOTING ALSO resolution A.[...](28) by which it adopted amendments to the International Convention on Load Lines, 1966, the International Convention on Tonnage Measurement of Ships, 1969 and the Convention on the International Regulation for Preventing Collisions at Sea, 1972, to make the III Code mandatory under these Conventions,

NOTING FURTHER that the Marine Environment Protection Committee and the Maritime Safety Committee have developed requirements for adoption by Contracting Governments to the International Convention for the Safety of Life at Sea, 1974, and the Protocol of 1988 relating to the International Convention on Load Lines, 1966, the International Convention for the Prevention of Pollution from Ships, 1973, as modified by the Protocol of 1978 relating thereto, the Protocol of 1997 to amend the International Convention for the Prevention of Pollution from Ships, 1973, as modified by the Protocol of 1978 relating thereto, and the International Convention on Standards of Training, Certification and Watchkeeping, 1978, as amended, respectively, to make the III Code mandatory under these instruments,

HAVING CONSIDERED the recommendations made by the Marine Environment Protection Committee, at its sixty-fifth session, and the Maritime Safety Committee, at its ninety-second session,

1. ADOPTS the 2013 non-exhaustive list of obligations under instruments relevant to the III Code, as set out in the annex to the present resolution;
2. URGES Governments of all States, in their capacity as flag, port and coastal States, to make as much use as possible of the list in the implementation of IMO instruments on a national basis;
3. REQUESTS the Maritime Safety Committee and the Marine Environment Protection Committee to keep the list under review and, under the coordination of the Council, to propose amendments thereto to the Assembly.

\* \* \*

ANNEX

**2013 NON-EXHAUSTIVE LIST OF OBLIGATIONS UNDER INSTRUMENTS  
RELEVANT TO THE IMO INSTRUMENTS IMPLEMENTATION CODE**

Table of Contents

Annex 1:	OBLIGATIONS OF CONTRACTING GOVERNMENTS/PARTIES
Annex 2:	SPECIFIC FLAG STATE OBLIGATIONS
Annex 3:	SPECIFIC COASTAL STATE OBLIGATIONS
Annex 4:	SPECIFIC PORT STATE OBLIGATIONS
Annex 5:	INSTRUMENTS MADE MANDATORY UNDER IMO CONVENTIONS
Annex 6:	SUMMARY OF AMENDMENTS TO MANDATORY INSTRUMENTS REFLECTED IN THE NON-EXHAUSTIVE LIST OF OBLIGATIONS (ANNEXES 1 TO 4)
Annex 7:	AMENDMENTS TO IMO INSTRUMENTS EXPECTED TO BE ACCEPTED AND TO ENTER INTO FORCE BETWEEN 1 JANUARY 2014 AND 1 JULY 2014

\* \* \*

ANNEX 1

**OBLIGATIONS OF CONTRACTING GOVERNMENTS/PARTIES**

The following table contains a non-exhaustive list of obligations, including those obligations imposed when a right is exercised.

<b>OBLIGATIONS OF CONTRACTING GOVERNMENTS/PARTIES</b>		
<b>SOURCE</b>	<b>SUMMARY DESCRIPTION</b>	<b>COMMENTS</b>
<b>TONNAGE 69</b>		
Art. 1	General obligation under the Convention	
Art. 5(2)	Force majeure	
Art. 8	Issue of a certificate by another Government	
Art. 10	Cancellation of certificate	
Art. 11	Acceptance of certificates	
Art. 15	Communication of information	
<b>LL 66 and LL PROT 88<sup>1</sup></b>		
Art. 1	General obligation under the Convention	
	General obligations	LL PROT 88 only (Art. I)
Art. 7(2)	Force majeure	
Art. 17	Issue or endorsement of certificates by another Government	amended by LL PROT 88
Art. 20	Acceptance of certificates	
Art. 25	Special rules drawn up by agreement	
Art. 26	Communication of information	
	Communication of information	LL PROT 88 only (Art. III)

<sup>1</sup> When the obligation does not derive from the International Convention on Load Lines, 1966, but solely from the Protocol of 1988 relating thereto, this is indicated in the "Comments" column.



	<b>OBLIGATIONS OF CONTRACTING GOVERNMENTS/PARTIES</b>	
<b>SOURCE</b>	<b>SUMMARY DESCRIPTION</b>	<b>COMMENTS</b>
<b>COLREG 72</b> Art. I	General obligations	
<b>STCW 78</b> Art. I Art. IV Art. XI(1) Reg. I/2.12 Reg. I/2.14 Reg. I/2.15 and 2.16 Reg. I/3 Reg. I/5 Reg. I/6.1 Reg. I/6.2 Reg. I/7 Reg. I/8.1 and 8.2 Reg. I/8.3 Reg. I/9.1 and 9.2	General obligations under the Convention Communication of information Promotion of technical co-operation Issuance of certificates of competency Maintenance of a register or registers of all certificates and endorsements Availability of information on the status of certificates of competency, endorsements and dispensations (as of 1 January 2017, available in English through electronic means) Principles governing near-coastal voyages, communication of information and incorporation of limits in the endorsements National provisions – impartial investigation, enforcement measures including penalties or disciplinary measures and cooperation Training and assessment – Administration, supervision and monitoring Qualification of those responsible for training and assessment Communication of the information as referred to in article IV of the STCW 78 Convention and A-I/7 of the STCW Code Quality standards system and periodical independent evaluation Communication of a report Medical standards, procedures for issuance of medical certificates, and recognition of medical practitioners	

	<b>OBLIGATIONS OF CONTRACTING GOVERNMENTS/PARTIES</b>	
<b>SOURCE</b>	<b>SUMMARY DESCRIPTION</b>	<b>COMMENTS</b>
Reg. I/9.6	Procedures for governing the validity of a medical certificate which expires in the course of a voyage	
Reg. I/11.4 and 11.5	Comparison of standards of competence – determination of need for appropriate refresher and updating training or assessment and formulation or promotion of the formulation of a structure of refresher and updating courses	
Reg. II/5.3	Comparison of standards of competence – determination of the need to update qualifications for able seamen to whom certificates are issued before 1 January 2012	
Reg. III/5.3	Comparison of standards of competence – determination of the need to update qualifications for ratings in engine department to whom certificates are issued before 1 January 2012	
Reg. III/6.3	Comparison of standards of competence – determination of the need to update qualifications for electro-technical officers to whom certificates are issued before 1 January 2012	
Reg. III/7.3	Comparison of standards of competence – determination of the need to update qualifications for electro-technical officers to whom certificates are issued before 1 January 2012	
Reg. VII/3.1	Principles governing the issue of alternative certificates	
<b>SOLAS 74</b>		
Art. I	General obligations under the Convention	in SOLAS PROT 78 and SOLAS PROT 88
Art. III	Communication of information	in SOLAS PROT 78 and SOLAS PROT 88
Art. V(c)	Carriage of persons in emergencies – reporting	
Art. VII	Special rules drawn up by agreement	

<b>OBLIGATIONS OF CONTRACTING GOVERNMENTS/PARTIES</b>		
<b>SOURCE</b>	<b>SUMMARY DESCRIPTION</b>	<b>COMMENTS</b>
Art. XI	Denunciation	in SOLAS PROT 88 (Art. VII)
Reg. I/13	Issue or endorsement of certificates by another Government	in SOLAS PROT 88
Reg. I/17	Acceptance of certificates	also reg. I/19(b)
Reg. I/21(b)	Casualties – reporting	
Reg. IV/5	Provision of radiocommunication services and communication of information on such provision	
Reg. IV/5-1	Global maritime distress and safety system identities – ensuring suitable arrangements	
Reg. V/5	Meteorological services and warnings	
Reg. V/6	Ice Patrol Service	
Reg. V/10	Ships' routeing	
Reg. V/11	Ship reporting systems	
Reg. V/12	Vessel traffic services	
Reg. V/13	Establishment and operation of aids to navigation	
Reg. V/31.2	Danger messages – bring to the knowledge of those concerned and communicate to other interested Governments	
Reg. V/33.1-1	Distress situations: obligations and procedures – coordination and cooperation	
Reg. VI/1.2	Appropriate information on safe carriage of cargoes	
Reg. VII/2.4	Issue of instructions on emergency response, etc.	
Reg. VII/7-1	Issue of instructions on emergency response, etc.	

	<b>OBLIGATIONS OF CONTRACTING GOVERNMENTS/PARTIES</b>	
<b>SOURCE</b>	<b>SUMMARY DESCRIPTION</b>	<b>COMMENTS</b>
<b>MARPOL</b>		
Art. 1	General obligations under the Convention	and Art. I of MARPOL PROT 78
Art. 4(2) and (4)	Violation	
Art. 5(1)	Certificates and special rules on inspection of ships – acceptance of certificates	
Art. 5(4)	Certificates and special rules on inspection of ships – no more favourable treatment	
Art. 6(1)	Detection of violations and enforcement of the Convention – cooperation	
Art. 6(3)	Detection of violations and enforcement of the Convention – furnishing evidence	
Art. 7	Undue delay to ships	
Art. 8	Reports on incidents involving harmful substances	
Art. 11	Communication of information	
Art. 12(2)	Casualties to ships – information to IMO	
Art. 17	Promotion of technical co-operation	
<b>Annex I</b>		
Reg. 8	Issue or endorsement of a certificate by another Government	
Reg. 15.7	Control of discharge of oil – investigations (Machinery spaces)	
Reg. 34.7	Control of discharge of oil – investigations (Cargo area)	
Reg. 38.3 <i>bis</i> and 38.4 <i>bis</i>	Consultation with IMO for circulation of information regarding reception facilities by Parties participating in regional arrangements	

	<b>OBLIGATIONS OF CONTRACTING GOVERNMENTS/PARTIES</b>	
<b>SOURCE</b>	<b>SUMMARY DESCRIPTION</b>	<b>COMMENTS</b>
<b>Annex II</b>		
Reg. 6.3	Categorization and listing of noxious liquid substances and other substances – establish and agree on provisional assessment and notify IMO	
Reg. 9.3.1, 9.3.2, 9.3.3 and 9.3.4	Issue or endorsement of a certificate by another Government	
Reg. 13.4	Control of discharges of residues – exemption for a pre-wash	
Reg. 18.2 <i>bis</i> and 18.2 <i>ter</i>	Consultation with IMO for circulation of information regarding reception facilities by Parties participating in regional arrangements	
Reg. 18.3	Reception facilities and cargo unloading terminal arrangements – agree and establish a date, notify IMO	
<b>Annex III</b>		
Reg. 1(3)	Application – issue detailed requirements	
<b>Annex IV</b>		
Reg. 6	Issue or endorsement of a certificate by another Government	
Reg. 12.1 <i>bis</i>	Consultation with IMO for circulation of information regarding reception facilities by Parties participating in regional arrangements	
<b>Annex V</b>		
Reg. 8.2 <i>bis</i>	Consultation with IMO for circulation of information regarding reception facilities by Parties participating in regional arrangements	
<b>Annex VI</b>		
Reg. 7	Issue or endorsement of a certificate by another Government	Addition related to IECC by MEPC.203(62)
Regs. 9.9.3 and 9.11.2	Transfer of flag – transmitting copies of the certificate and the relevant survey report	

	<b>OBLIGATIONS OF CONTRACTING GOVERNMENTS/PARTIES</b>	
<b>SOURCE</b>	<b>SUMMARY DESCRIPTION</b>	<b>COMMENTS</b>
Reg. 11.1	Detection of violations and enforcement – cooperation	
Reg. 11.2	Inspection report in case of detection of violations	
Reg. 11.3	Detection of violations and enforcement – information to flag State and master on violations detected	
Reg. 11.5	Transmission of report to requesting Party	
Reg. 13.7.1	Certification of an Approved Method and communication to IMO	
Reg. 17.1	Adequate Reception Facilities	
Reg. 17.1 <i>bis</i>	Consultation with IMO for circulation of information regarding reception facilities by Parties participating in regional arrangement	
Reg. 17.3	Reception Facilities unavailable or inadequate – communication to IMO	
Reg. 18.1	Availability of fuel oils and communication to IMO	
Reg. 18.2.1	Ship not compliant with fuel oil standards	
Reg. 18.2.3	Action taken, including not taking control measures	
Reg. 18.2.5	Evidence of the non-availability of compliant fuel oil – communication to IMO	
Reg. 18.9	Authorities designated for register of local suppliers, bunker delivery note and sample, fuel oil quality, actions against fuel oil suppliers of non-compliance, informing the Administration of any ship receiving non-compliant fuel oil and communication to IMO of non-compliant fuel oil suppliers as referred to in the paragraph	
<b>ISM Code</b> Para 14.3	Extension of validity of Interim SMC by another Contracting Government	

	<b>OBLIGATIONS OF CONTRACTING GOVERNMENTS/PARTIES</b>	
<b>SOURCE</b>	<b>SUMMARY DESCRIPTION</b>	<b>COMMENTS</b>
<b>1994 HSC Code</b>		
Para 1.8.2	Issue of certificates by another Government	
Para 14.2.1.12	Definition of "sea area A1"	as may be defined
Para 14.2.1.13	Definition of "sea area A2"	as may be defined
<b>2000 HSC Code</b>		
Para 1.8.2	Issue of certificates by another Government	
Para 14.2.1.13	Definition of "sea area A1"	as may be defined
Para 14.2.1.14	Definition of "sea area A2"	as may be defined
<b>IMDG Code</b>		
Section 1.3.1	Training of shoreside personnel – establishment of period for keeping records of training	
Section 1.5.2	Radiation protection programme – role of Competent Authority	
Section 1.5.3	Quality assurance programmes – role of Competent Authority	
Chapter 3.3	Approval of metal hydride storage system(s) installed in conveyances or in completed conveyance components or intended to be installed in conveyances	
Chapter 4.1	Approval of packagings as referred to in the Chapter – role of Competent Authority	
Section 5.1.5	General provisions for class 7 – role of Competent Authority	
Chapter 5.5	Determining the period between fumigant application and loading of fumigated cargo transport unit on board the ship	
Chapter 6.2	Approval of pressure receptacles, aerosol dispensers, small receptacles containing gas and fuel cell cartridges containing liquefied flammable gas – role of Competent Authority	

	<b>OBLIGATIONS OF CONTRACTING GOVERNMENTS/PARTIES</b>	
<b>SOURCE</b>	<b>SUMMARY DESCRIPTION</b>	<b>COMMENTS</b>
Section 6.2.2.6.2	General provisions – role of Competent Authority	
Section 6.3.2	Quality assurance programme – role of Competent Authority	
Section 6.3.5	Procedures for performance and frequency of tests – role of Competent Authority	
Chapter 6.4	Approval of package design and materials for class 7 – role of Competent Authority	
Section 6.5.4	Testing, certification and inspection – role of Competent Authority	
Chapter 6.6	Provisions for the construction and testing of large packagings – role of Competent Authority	
Chapter 6.7	Provisions for the design, construction, inspection and testing of portable tanks and multiple-element gas containers – role of Competent Authority	
Chapter 6.8	Provisions for road tank vehicles – role of Competent Authority	
Section 7.1.14	Stowage of goods of class 7 – role of Competent Authority	
Chapter 7.9	Exemptions, approvals and certificates – notification to IMO and recognition of approvals and certificates	
<b>Casualty Investigation Code</b>		
Para 4/4.1	Detailed contact information of the marine safety investigation Authority(ies) to IMO	
Paras 5/5.1 and 5.2	Notification of a marine casualty	
Paras 7/7.1 and 7.2	Agreement to conduct a marine safety investigation	
Para 8/8.1	Powers provided for investigator(s)	
Para 9/9.2	Coordination for parallel investigations	



	<b>OBLIGATIONS OF CONTRACTING GOVERNMENTS/PARTIES</b>	
<b>SOURCE</b>	<b>SUMMARY DESCRIPTION</b>	<b>COMMENTS</b>
Para 10/10.1	Cooperation in investigating	
Para 11/11.1	Investigation not to be subject to external direction	
Paras 13/13.1,13.4 and 13.5	Draft marine safety investigation reports	
Paras 14/14.1 and 14.2	Marine safety investigation reports – communication to IMO	
Para 14/14.4	Marine safety investigation reports – available to public and shipping industry	
<b>IBC Code</b>		
Para 1.5.3	Maintenance of conditions after survey	
Para 1.5.5.1	Issue or endorsement of International Certificate of Fitness by another Government	
<b>BCH Code</b>		
Para 1.6.4.1	Issue or endorsement of certificate by another Government	
<b>IGC Code</b>		
Para 1.5.5.1	Issue or endorsement of certificate by another Government	
<b>STCW Code, part A</b>		
Section A-I/6.1	Training and assessment of seafarers for certification	
Section A-I/6.3	Qualifications of instructors, supervisors and assessors	
Section A-I/6.7	Training and assessment within an institution	
Section A-I/7.2	Communication of information – initial communication (within one year of entry into force of regulation I/7)	

<b>OBLIGATIONS OF CONTRACTING GOVERNMENTS/PARTIES</b>		
<b>SOURCE</b>	<b>SUMMARY DESCRIPTION</b>	<b>COMMENTS</b>
Section A-I/7.3, 7.4 and 7.5	Communication of information – subsequent reports (within the periods as referred to in paragraphs 7.3, 7.4 and 7.5)	
Section A-I/8.1 and 8.3	National objectives and quality standards	
Section A-I/9.1	Medical standards – eyesight standards, physical and medical fitness	
Section A-I/9.4	Provisions for recognizing medical practitioners and maintenance of a register of recognized medical practitioners	
Section A-I/9.5 and 9.6	Guidance, processes and procedures for the conduct of medical fitness examinations and issuance of medical certificates	
Section A-I/12.1	General performance standards for simulators used in training	
Section A-I/12.2	General performance standards for simulators used in assessment of competence	
Section A-I/12.6	Simulator training objectives	
Section A-I/12.9	Qualification of instructors and assessors	
Section A.VIII/2.9	Watchkeeping at sea – directing the attention of companies, masters, chief engineer officers and watchkeeping personnel to observe principles in parts 4-1 and 4-2	

\* \* \*

ANNEX 2

**SPECIFIC FLAG STATE OBLIGATIONS**

The following table contains a non-exhaustive list of obligations, including those obligations imposed when a right is exercised.

<b>SPECIFIC FLAG STATE OBLIGATIONS</b>		
<b>SOURCE</b>	<b>SUMMARY DESCRIPTION</b>	<b>COMMENTS</b>
<b>TONNAGE 69</b>		
Art. 6	Determination of tonnages	
Art. 7(2)	Issue of certificates	
Annex I, reg. 1(3)	Novel types of craft – determination of tonnage and communication to IMO on method used	
Annex I, reg. 5(3)(b)	Change of net tonnage – Alterations or modifications deemed by the Administration to be of a major character	
Annex I, reg. 7	Measurement and calculation	
<b>LL 66 and LL PROT 88<sup>2</sup></b>		
	Existing certificates	LL PROT 88 only (Art.II-2)
Art. 6(3)	Exemptions – reporting	
Art. 8(2)	Equivalent – reporting	
Art. 9(2)	Approvals for experimental purposes – reporting	
Art. 13	Surveys and marking	amended by LL PROT 88
Art. 14	Initial, renewal and annual survey	amended by LL PROT 88
Art. 16(3)	Issue of certificates	
Art. 19	Duration and validity of certificate	amended by LL PROT 88
Art. 23	Casualties	

<sup>2</sup> When the obligation does not derive from the International Convention on Load Lines, 1966, but solely from the Protocol of 1988 relating thereto, this is indicated in the "Comments" column.

<b>SPECIFIC FLAG STATE OBLIGATIONS</b>		
<b>SOURCE</b>	<b>SUMMARY DESCRIPTION</b>	<b>COMMENTS</b>
Annex I, reg. 1	Strength of hull  Strength and intact stability of ships	LL PROT 88 only (Annex I, reg. 1)
Annex I, reg. 2	Application – Assignment of freeboard  Authorization of recognized organizations	amended by LL PROT 88  LL PROT 88 only (Annex I, reg. 2-1)
Annex I, reg. 8	Details of marking	
Annex I, reg. 10	Stability information – approval	amended by LL PROT 88
Annex I, reg. 12	Doors	amended by LL PROT 88
Annex I, reg. 14	Cargo and other hatchways	amended by LL PROT 88
Annex I, reg. 15	Hatchways closed by portable covers and secured weather tight by tarpaulins and battering devices	amended by LL PROT 88
Annex I, reg. 16(1)	Hatchway coamings – reduced heights	amended by LL PROT 88 (Annex I, reg. 14-1(2))
Annex I, reg. 16(4)	Securing arrangements  Machinery space openings	amended by LL PROT 88 (Annex I, reg. 16(6))  LL PROT 88 only (Annex I, reg. 17(4))
Annex I, reg. 19	Ventilators	amended by LL PROT 88
Annex I, reg. 20	Air pipes  Cargo ports and other similar openings – applicable national standards	amended by LL PROT 88  LL PROT 88 only (Annex I, reg. 21(5))
Annex I, reg. 22	Scuppers, inlets and discharges	amended by LL PROT 88
Annex I, reg. 25	Protection of the crew	amended by LL PROT 88
Annex I, reg. 27	Freeboards – Types of ships	amended by LL PROT 88
Annex I, reg. 28	Freeboard tables	amended by LL PROT 88
Annex I, reg. 39	Minimum bow height and reserve buoyancy  Lashing system	amended by LL PROT 88 LL PROT 88 only (Annex I, reg. 44(6))

<b>SPECIFIC FLAG STATE OBLIGATIONS</b>		
<b>SOURCE</b>	<b>SUMMARY DESCRIPTION</b>	<b>COMMENTS</b>
<b>COLREG 72</b>		
Annex I, paragraph 14	Approval of construction of lights and shapes and the installation of lights on board	
Annex III, paragraph 3	Approval of construction, performance and installation of sound signal appliances on board	
<b>STCW 78</b>		
Art. VI	Certificates	
Art. VIII(3)	Dispensation – reporting	
Art. IX(2)	Equivalentents – reporting	
Reg. I/2.1, 2.2, 2.7 and 2.8	Issuance and endorsements of certificate of competency	
Reg. I/10.1 and 10.2	Recognition of certificates and seafarer's knowledge of the maritime legislation	
Reg. I/11.6	Availability – recent changes in national and international regulations	
Reg. I/13.3	Conduct of trials – safety, security and pollution prevention	
Reg. I/13.5 and 13.8.1	Results of trials – Communication	
Reg. I/13.7	Respect objections to particular trials	
Reg. I/13.8	Respect objections by other Parties when authorizing ships to continue to operate with the system under trial	
Reg. I/14.1	Responsibilities of companies	
Reg. IV/1.2	Application – appropriate certificates for radio operators	

<b>SPECIFIC FLAG STATE OBLIGATIONS</b>		
<b>SOURCE</b>	<b>SUMMARY DESCRIPTION</b>	<b>COMMENTS</b>
Reg. V/1.7	Mandatory minimum requirements for the training and qualification of masters, officers and ratings on oil and chemical tankers	
Reg. V/1-2.5	Mandatory minimum requirements for the training and qualification of masters, officers and ratings on liquefied gas tankers	
Reg. V/2.1	Applicability of the requirements on domestic voyages	
Reg. V/2.8	Mandatory minimum requirements for the training and qualification of masters, officers, ratings and other personnel on passenger ships	
Reg. VIII/1.1 and 1.2	Fitness for duty – preventing fatigue and preventing drug and alcohol abuse	
Reg. VIII/2.1 and 2.2	Watchkeeping arrangements and principles – direction and requirements	
<b>SOLAS 74</b>		
Reg. I/4(b)	Exemptions – reporting	
Reg. I/5(b)	Equivalentents – reporting	
Reg. I/6	Inspection and survey	in SOLAS PROT 78 and SOLAS PROT 88
Reg. I/7	Survey of passenger ships	in SOLAS PROT 88
Reg. I/8	Survey of life-saving appliances and other equipment of cargo ships	in SOLAS PROT 88
Reg. I/9	Survey of radio installations of cargo ships	in SOLAS PROT 88
Reg. I/10	Survey of structure, machinery and equipment of cargo ships	in SOLAS PROT 88
Reg. I/12	Issue of certificates	in SOLAS PROT 88
	Issue and endorsement of certificates	in SOLAS PROT 88
Reg. I/14	Duration and validity of certificates	in SOLAS PROT 88
Reg. I/15	Forms of certificates and records of equipment	in SOLAS PROT 88

<b>SPECIFIC FLAG STATE OBLIGATIONS</b>		
<b>SOURCE</b>	<b>SUMMARY DESCRIPTION</b>	<b>COMMENTS</b>
Reg. I/18	Qualification of certificates	
Reg. I/21	Casualties	
Reg. II-1/1.2	Compliance with earlier requirements	revised SOLAS chapter II-1 adopted by MSC 80 and MSC 82
Reg. II-1/3-2	Approval of corrosion prevention systems of seawater ballast tanks	
Reg. II-1/3-2.4	Maintenance of the protective coating	
Reg. II-1/3-3.2	Approval of means of access to tanker bows	
Reg. II-1/3-4.1.2.2 and 3-4.1.3	Approval of emergency towing arrangements on tankers	
Reg. II-1/3-6.2.3	Means of access to cargo and other spaces – satisfaction of the Administration as well as survey	
Reg. II-1/3-6.4.1	Approval of Ship Structure Access Manual	
Reg. II-1/3-8.3	Appropriate requirements for towing and mooring equipment	
Reg. II-1/3-9.1	Means of embarkation and disembarkation	
Reg. II-1/4.2	Alternative methodologies – communication to IMO	
Reg. II-1/4.4	Beneficial or adverse effects of fitting structures as defined by the regulation	
Reg. II-1/5-1.1	Stability information to the Administration	
Reg. II-1/7-2.5	Acceptance to equalization devices and their control	
Reg. II-1/13.9.2	Number and arrangements of doors with a device preventing unauthorized opening	
Reg. II-1/13.11.2	Special consideration for tunnels piercing watertight bulkheads	

<b>SPECIFIC FLAG STATE OBLIGATIONS</b>		
<b>SOURCE</b>	<b>SUMMARY DESCRIPTION</b>	<b>COMMENTS</b>
Reg. II-1/15.2	Arrangement and efficiency of the means for closing any opening in the shell plating	
Reg. II-1/15.6	Special sanction for automatic ventilating sidescuttles	
Reg. II-1/15.8.5	Material of pipes as referred to in the regulation	
Reg. II-1/16.1.1	Construction and initial tests of watertight doors, sidescuttles, etc.	
Reg. II-1/16-1.1	Construction and initial tests of watertight decks, trunks, etc.	
Reg. II-1/17-1.2	Indicators for closing appliances that could lead to flooding of a special category space or ro-ro space	
Reg. II-1/19.3 and 19.4	Damage control information – General and specific precautions	
Reg. II-1/22.4	Determination for watertight doors permitted to remain open	
Reg. II-1/26.2	Consideration of reliability of single essential propulsion components	
Reg. II-1/29.1, .2.1 and .6.3	Steering gear	
Reg. II-1/29.17.2	Adoption of regulations on rudder actuators for tankers, chemical tankers and gas carriers	
Reg. II-1/35-1.3.7.2 and 3.9	Bilge pumping arrangements	
Reg. II-1/40.2	Electrical installations – ensuring uniformity	
Reg. II-1/42.1.3	Emergency source of electrical power in passenger ships	
Reg. II-1/43.1.3	Emergency source of electrical power in cargo ships	
Reg. II-1/44.2	Approval of automatically starting emergency generating sets	



<b>SPECIFIC FLAG STATE OBLIGATIONS</b>		
<b>SOURCE</b>	<b>SUMMARY DESCRIPTION</b>	<b>COMMENTS</b>
Reg. II-1/45.3.3, 45.5.3, 45.5.4, 45.9.3, 45.10, and 45.11	Precautions against shock, fire and other hazards of electrical origin	
Reg. II-1/46.2 and .3	Additional requirements for periodically unattended machinery space	
Reg. II-1/53.1	Special requirements for machinery, boiler and electrical installations	
Reg. II-1/55.3, 55.4.1 and 55.6	Evaluation of the alternative design and arrangements and re-evaluation due to change of conditions	
Reg. II-1/55.5	Alternative design and arrangements – communication to IMO	
Reg. II-2/1.2.1	Approval of fire protection arrangements in existing ships	
Reg. II-2/1.6.2.1.2 and 1.6.6	Application of requirements for tankers	
Reg. II-2/4.2.2.5.1	Approval of material for oil fuel pipes and their valves and fittings	
Reg. II-2/4.3	Approval of gaseous fuel systems used for domestic purposes	
Reg. II-2/4.5.1.4.4	Installation of cargo oil lines where cargo wing tanks are provided	
Reg. II-2/4.5.3.3	Requirements for safety devices in venting systems	
Reg. II-2/4.5.5.2.1	Requirements for inert gas system on chemical tankers	
Reg. II-2/4.5.6.3	Arrangements for inerting, purging or gas-freeing	see reg. II-2/4.5.5.3.1
Reg. II-2/5.2.2.5	Positioning of controls for any required fire-extinguishing system in passenger ships	see reg. II-2/8.3.3 and II-2/9.5.2.3
Reg. II-2/5.2.3.1	Special consideration to maintaining the fire integrity of periodically unattended machinery spaces	

<b>SPECIFIC FLAG STATE OBLIGATIONS</b>		
<b>SOURCE</b>	<b>SUMMARY DESCRIPTION</b>	<b>COMMENTS</b>
Reg. II-2/7.3.2	Initial and periodical tests	
Reg. II-2/7.6	Protection of cargo spaces in passenger ships	
Reg. II-2/8.3.4	Release of smoke from machinery spaces – passenger ships	
Reg. II-2/9.2.2.1.5.1	Approval of equivalent means of controlling and limiting a fire on ships designed for special purposes	
Reg. II-2/9.2.2.3.1	Fire integrity of bulkheads and decks in ships carrying more than 36 passengers	
Reg. II-2/9.2.2.4.4, 9.2.3.3.4 and 9.2.4.2.4	Fire integrity of bulkheads and decks	see reg. II-2/11.2
Reg. II-2/9.3.4	Approval of structural fire protection details, taking into account the risk of heat transmission	
Reg. II-2/9.5.2.4	Protection of openings in machinery space boundaries	
Reg. II-2/10.2.1.2.1.3	Provisions for fixed water fire-extinguishing arrangements for periodically unattended machinery spaces	
Reg. II-2/10.2.1.2.2.1	Ready availability of water supply	
Reg. II-2/10.2.3.1.1	Approval of non-perishable material for fire hoses	
Reg. II-2/10.2.3.2.1	Number and diameter of fire hoses	
Reg. II-2/10.3.2.1	Arrangement of fire extinguishers	
Reg. II-2/10.6.1.1	Type approval of automatic sprinkler, fire detection and fire alarm system	
Reg. II-2/10.6.3.2	Approval of fire-extinguishing arrangement for flammable liquid lockers	
Reg. II-2/10.7.1.2	Fixed gas fire-extinguishing systems for general cargo	

<b>SPECIFIC FLAG STATE OBLIGATIONS</b>		
<b>SOURCE</b>	<b>SUMMARY DESCRIPTION</b>	<b>COMMENTS</b>
Reg. II-2/10.7.1.4	Issue of an Exemption Certificate	
Reg. II-2/13.3.1.4	Provision of means of escape from, or access to, radiotelegraph stations	
Reg. II-2/13.3.2.5.1	Lighting or photoluminescent equipment to be evaluated, tested and applied in accordance with the FSS Code	
Reg. II-2/13.3.2.6.2	Normally locked doors that form part of an escape route – Quick release mechanisms	
Reg. II-2/13.5.1	Means of escape on passenger ships from special category and open ro-ro spaces to which any passengers carried can have access	
Reg. II-2/17.4.1 and 17.6	Evaluation and approval of the engineering analysis for alternative design and arrangements for fire safety	
Reg. II-2/17.5	Alternative design and arrangements for fire safety – communication of information to IMO	
Reg. II-2/19.4	Provision of document of compliance	
Reg. II-2/20.4.1	Provision and approval of fixed fire detection and fire alarm systems	
Reg. II-2/20.6.1.4.2	Adverse effect as referred to in the regulation – Approval of stability information	
Reg. II-2/21.5.2	Alternate space for medical care	
Reg. III/4	Evaluation, testing and approval of life-saving appliances and arrangements	
Reg. III/5	Production tests for life-saving appliances	
Reg. III/20.8.1.2	Approval of servicing stations	
Reg. III/20.8.5	Extension of liferaft service intervals – notification to IMO	

<b>SPECIFIC FLAG STATE OBLIGATIONS</b>		
<b>SOURCE</b>	<b>SUMMARY DESCRIPTION</b>	<b>COMMENTS</b>
Reg. III/20.11.1 and 20.11.2	Periodic servicing of launching appliances and on-load release gear – thorough examination at the annual surveys	
Reg. III/26.2.4	Approval of liferafts on ro-ro passenger ships	
Reg. III/26.3.1 and 26.3.2	Approval of fast rescue boats and their launching appliances on ro-ro passenger ships	
Reg. III/28	Approval of helicopter landing and pick-up areas on ro-ro passenger ships	
Reg. III/38.3, 38.4.1 and 38.6	Evaluation of the alternative design and arrangements and re-evaluation due to change of conditions	
Reg. III/38.5	Alternative design and arrangements – communication to IMO	
Reg. IV/3.3	Exemptions – reporting to IMO	
Reg. IV/14.1	Type approval of radio equipment	
Reg. IV/15.5	Ensure radio equipment is maintained	
Reg. IV/16.1	Radio personnel	
Reg. IV/17	Radio records	
Reg. V/3.3	Exemptions and equivalents – reporting to IMO	
Reg. V/14	Ships' manning	
Reg. V/16	Maintenance of equipment	
Reg. V/17	Electromagnetic compatibility	
Reg. V/18.1	Type approval of navigational systems and equipment and voyage data recorder	
Reg. V/18.5	Requirement for quality control system at manufacturers	
Reg. V/23.3.3.1.3	Pilot transfer arrangements	
Reg. V/23.6.1	Type approval of mechanical pilot hoists	

<b>SPECIFIC FLAG STATE OBLIGATIONS</b>		
<b>SOURCE</b>	<b>SUMMARY DESCRIPTION</b>	<b>COMMENTS</b>
Reg. VI/3.1 and 3.2	Provision of equipment for oxygen analysis and gas detection and training of crews in their use	
Reg. VI/5.6	Approval of Cargo Securing Manual	
Reg. VI/6	Acceptability for shipment	
Reg. VI/9.2	Grain loading information	
Reg. VII/5	Approval of Cargo Securing Manual	
Reg. VII/15.2	Warships – INF cargo	
Reg. VIII/4	Approval of design, construction and standards of inspection and assembly of reactor installations	
Reg. VIII/6	Ensure radiation safety	
Reg. VIII/7(a)	Approval of safety assessment	
Reg. VIII/8	Approval of operating manual	
Reg. VIII/10(f)	Issue of certificates	
Reg. IX/4.1	Issue of Document of Compliance (DOC)	
Reg. IX/4.3	Issue of Safety Management Certificate (SMC)	
Reg. IX/6.1	Periodical verification of the safety management system	
Reg. XI-1/1	Authorization of recognized organizations	
Reg. XI-1/2	Enhanced surveys	
Reg. XI-1/3.5.4	Ship identification number – approval of method of marking	
Reg. XI-1/3-1.2	Registered owner identification number	
Reg. XI-1/5.3	Issue of Continuous Synopsis Record (CSR)	
Reg. XI-1/5.4.2	Amendments to CSR	
Reg. XI-1/5.4.3	Authorize and require changes to be made to CSR	

<b>SPECIFIC FLAG STATE OBLIGATIONS</b>		
<b>SOURCE</b>	<b>SUMMARY DESCRIPTION</b>	<b>COMMENTS</b>
Reg. XI-1/5.8	Former flag State to send CSR to new flag State	
Reg. XI-1/5.9	Append previous CSR to new CSR	
Reg. XI-1/6	Investigations of marine casualties and incidents	
Reg. XII/8.1	Endorsement of booklet required by reg. VI/7.2	
Reg. XII/9.2	Approval of bilge well high water level alarms	
Reg. XII/11.3	Loading instrument – approval of software for stability calculations	
<b>MARPOL</b>		
Art. 4(1) and (3)	Violation	
Art. 6(4)	Detection of violations and enforcement of the Convention – investigations	
Art. 12(1)	Casualties to ships – investigations	
<b>Annex I</b>		
Reg. 2.6.2	Application – an oil tanker delivered on or before 1 June 1982 engaged in specific trades: agreement with port States	
Reg. 3.3	Exemptions and waivers – reporting	
Reg. 4.3	Exceptions – discharge of substances containing oil for the purpose of combating pollution incidents	
Reg. 5.2	Equivalentents – reporting	
Reg. 6	Surveys	
Reg. 7	Issue or endorsement of certificate	
Reg. 10.9.3	Transfer of flag	

<b>SPECIFIC FLAG STATE OBLIGATIONS</b>		
<b>SOURCE</b>	<b>SUMMARY DESCRIPTION</b>	<b>COMMENTS</b>
Reg. 12A.12	Oil fuel tank protection – approval of the design and construction of ships	
Reg. 14.3	Oil filtering equipment – volume of oil bilge holding tank	
Reg. 14.4	Oil filtering equipment – ships of less than 400 gross tonnage	
Reg. 14.6 and 14.7	Oil filtering equipment – approval	
Reg. 15.6.2	Control of discharge of oil – ships of less than 400 gross tonnage: design approval	
Reg. 18.8.2, 18.8.3 and 18.8.4	Requirements for product carriers of 40,000 tonnes deadweight and above – arrangement and operation, approval of oil content meter, clean ballast tank operational manual	
Reg. 18.10.1.1	Segregated ballast tanks – oil tanker delivered on or before 1 June 1982 having special ballast arrangements: approval	
Reg. 18.10.1.2	Segregated ballast tanks – oil tanker delivered on or before 1 June 1982 having special ballast arrangements: agreement with port States	
Reg. 18.10.3	Segregated ballast tanks – oil tanker delivered on or before 1 June 1982 having special ballast arrangements: communication to IMO	
Reg. 20.8.1	Double hull and double bottom requirements for oil tankers delivered before 6 July 1996 – communication to IMO	
Reg. 21.8.1	Prevention of oil pollution from oil tankers carrying heavy grade oil as cargo – communication to IMO	
Reg. 23.3.1	Accidental oil outflow performance – Calculation of mean oil outflow parameter	
Reg. 25.5	Hypothetical outflow of oil – information to IMO on accepted arrangements	

<b>SPECIFIC FLAG STATE OBLIGATIONS</b>		
<b>SOURCE</b>	<b>SUMMARY DESCRIPTION</b>	<b>COMMENTS</b>
Reg. 27.3	Intact stability – approval of written procedures for liquid transfer operation	
Reg. 28.3.4	Subdivision and damage stability – sufficient stability during flooding	
Reg. 29.2.1	Slop tanks – approval	
Reg. 30.6.5.2	Pumping, piping and discharge arrangement – establishment of requirements	
Reg. 30.7	Pumping, piping and discharge arrangement – positive means of loading, transporting or discharging cargo	
Reg. 31.2 and 31.4	Oil discharge monitoring and control system – approval	
Reg. 32	Oil/water interface detector – approval	
Reg. 33.1	Crude oil washing requirement – compliance with requirement	
Reg. 33.2	Crude oil washing requirements – establishment of requirements	
Reg. 35.1	Crude oil washing operations – Operations and Equipment Manual	
Reg. 36.9	Oil Record Book, Part II – development of oil record book for ships of less than 150 gross tonnage	
Reg. 37.1	Shipboard oil pollution emergency plan – approval	
Reg. 38.7.2	Reception facilities within special areas: Antarctic area – sufficient capacity	
Reg. 38.8	Reception facilities – Notification on alleged inadequacies of port reception facilities	
Reg. 39.2.2	Special requirements for fixed or floating platforms – approval of record form	



<b>SPECIFIC FLAG STATE OBLIGATIONS</b>		
<b>SOURCE</b>	<b>SUMMARY DESCRIPTION</b>	<b>COMMENTS</b>
Reg. 41.1	Oil tankers Ship to Ship (STS) operations Plan to be approved	
<b>Annex II</b>		
Reg. 3.1.3	Exceptions – approval of discharge of NLS for the purpose of combating pollution incidents	
Reg. 4.1.2	Exemptions – communication to IMO on relaxations	
Reg. 4.3.4	Exemptions – communication to IMO	
Reg. 4.4.5	Exemptions – communication to IMO	
Reg. 5.1	Equivalents – substitution of operational method	
Reg. 5.2	Equivalents – communication to IMO on alternatives	
Reg. 5.3.4 and 5.3.5	Equivalents – pumping and piping arrangement, approval of manual	
Reg. 6.3	Establishment of Tripartite Agreements – Notification to IMO	
Reg. 8	Surveys	
Reg. 9	Issue or endorsement of certificates	
Reg. 10.7	Expiry date of existing certificate	
Reg. 10.9.3	Transfer of flag	
Reg. 11.2	Design, construction, equipment and operations – establishment of appropriate measures	
Reg. 12.5	Pumping, piping, unloading arrangements and slop tanks – approval of pumping performance test	
Reg. 13.3	Control of discharges of residues of NLS – approval of ventilation procedure	

<b>SPECIFIC FLAG STATE OBLIGATIONS</b>		
<b>SOURCE</b>	<b>SUMMARY DESCRIPTION</b>	<b>COMMENTS</b>
Reg. 13.5	Control of discharges of residues of NLS – approval of tank washing procedure	
Reg. 14.1	Procedures and arrangements manual – approval	
Reg. 17.1	Shipboard marine pollution emergency plan for NLS – approval	
Reg. 18.5	Notification on alleged inadequacies of port reception facilities	
<b>Annex IV</b>		
Reg. 4	Surveys	
Reg. 5	Issue or endorsement of certificates	
Reg. 8.8.2	Transfer of flag	
Reg. 9.1	Approval of sewage systems	
Reg. 9.2	Approval of sewage systems (passenger ships operating in special areas)	
Reg. 11.1.1	Approval of rate of discharge	
Reg. 12.2	Notification on alleged inadequacies of port reception facilities	
<b>Annex V</b>		
Reg. 6.3.2	Sufficient capacity for the retention of all garbage on board ships before entering the Antarctic area	
Reg. 8.2	Notification on alleged inadequacies of port reception facilities	
<b>Annex VI</b>		
Reg. 3.2 and 3.3.2	Exceptions and exemptions	
Reg. 4.2 and 4.4	Equivalentents and communication to IMO	
Reg. 5	Surveys and certification	Addition related to IEEC MEPC.203(62)

<b>SPECIFIC FLAG STATE OBLIGATIONS</b>		
<b>SOURCE</b>	<b>SUMMARY DESCRIPTION</b>	<b>COMMENTS</b>
Reg. 6	Issue or endorsement of Certificate	Addition related to IEEC by MEPC.203(62)
Reg. 9.1 and 9.10	Duration and validity of certificate	Addition related to IEEC by MEPC.203(62)
Reg. 9.9.3	Transfer of flag	
Reg. 11.4	Detection of violations and enforcement – investigations and communication to the Party and IMO	
Reg. 12.6	Ozone Depleting Substances Record Book – approval of alternative forms of record keeping	
Reg. 13.1.1.2 and 13.1.2.2)	Nitrogen oxides – Acceptance of identical replacement and alternative control measures	
Reg. 13.2.2	Acceptance of installation of Tier II engine in lieu of Tier III where Tier III engine could not be accommodated	
Reg. 13.5.2.2	Combined nameplate diesel engine – application as referred to in the paragraph	
Reg. 13.7.2	Approved method not commercially available	
Reg. 14.6	Sulphur oxides – prescription of logbook	
Reg. 15.5	Volatile organic compounds – approval of vapour collection systems	
Reg. 15.6	VOC Management Plan – approval	
Reg. 16.6.1	Shipboard incineration – approvals	
Reg. 19.6	Information regarding application, suspension, withdrawal or declining of waiving the requirements of Reg. 20 (in accordance with Reg.19.4) – communication to the Organization	Refer to Reg. 19.4
Reg. 23	Cooperation with other parties – promotion of development – transfer of technology, exchange of information relating to the improvement of energy efficiency of ships	

<b>SPECIFIC FLAG STATE OBLIGATIONS</b>		
<b>SOURCE</b>	<b>SUMMARY DESCRIPTION</b>	<b>COMMENTS</b>
Appendix IV, para 1	Type approval as referred to in the paragraph	
Appendix VI, para 1.2, para 2.1 and para 3.1	Fuel verification procedure – management and sample delivery	
<b>Res. MSC.133(76), as amended</b>	Technical provisions for means of access for inspections	
Para 3.7	Vertical or spiral ladders – acceptance	
Para 3.9.7	Other means of access – approval and acceptance	
<b>Res. A.739(18), as amended</b>	Guidelines for the authorization of organizations acting on behalf of the Administration	
Para 2	Assignment of authority	
Para 3	Verification and monitoring	
<b>ISM Code</b>		
Para 13.2	Issue of DOC	
Para 13.4	Annual verification (DOC)	
Para 13.5	Withdrawal of DOC	
Para 13.7	Issue of SMC	
Para 13.8	Intermediate verification (SMC)	
Para 13.9	Withdrawal of SMC	
Para 14.1	Issue of Interim DOC	
Para 14.2	Issue of Interim SMC	
Para 14.4	Verification required for issuance of an Interim SMC	
Para 15.1	Verification – acceptance of procedures	
Para 16	Forms of certificates	

<b>SPECIFIC FLAG STATE OBLIGATIONS</b>		
<b>SOURCE</b>	<b>SUMMARY DESCRIPTION</b>	<b>COMMENTS</b>
<b>INF Code</b>		
Para 1.3.2	Issue of certificate	
Para 2.1	Damage stability (INF.1 ship)	
Para 3.1	Fire safety measures (INF.1 cargo)	
Para 4.1.3	Temperature control of cargo spaces (INF.1, 2 and 3 ship)	
Para 6.2	Safe stowage and securing – approval of principles	
Para 7.1	Electrical power supplies (INF.1 ship)	
Chapter 8	Radiological protection	
Chapter 9	Management and training	
Para 10.2	Shipboard emergency plan – approval	
<b>FSS Code</b>		
Para 1/4	Use of toxic extinguishing media	
Para 4/2	Type approval of fire extinguishers	
Para 4/3.1.1.2	Determine equivalents of fire extinguishers	
Para 4/3.2.2.2	Approval of foam concentrate	
Para 5/2.1.1.4	Containers for the storage of fire-extinguishing medium, etc.	
Para 5/2.1.2.1	System flow calculations	
Para 5/2.1.2.3	Spare parts	
Para 5/2.3	Steam systems	
Para 5/2.5	Equivalent systems – approval	
Paras 6/2.2.1.1 and 6/2.3.1.1	Foam concentrates – approval	

<b>SPECIFIC FLAG STATE OBLIGATIONS</b>		
<b>SOURCE</b>	<b>SUMMARY DESCRIPTION</b>	<b>COMMENTS</b>
Para 7/2.1	Fixed pressure water-spraying fire-extinguishing systems – approval	
Para 7/2.2	Equivalent systems – approval	
Para 7/2.3	Fixed pressure water-spraying fire-extinguishing systems for cabin balconies – approval	
Para 8/2.1.2	Equivalent sprinkler systems – approval	
Para 9/2.3.1.2	Sensitivity limits of smoke detectors in other spaces	
Para 9/2.3.1.3	Heat detectors temperature limits	
Para 9/2.3.1.7	Fixed fire detection and fire alarm systems for cabin balconies – approval	
Para 9/2.4.1.3	Limiting the number of enclosed spaces included in each section	
Para 9/2.5.2	Testing on ships with self-diagnostic system – determination of requirements	
Para 10/2.1.2	Sequential scanning – overall response time	
Para 10/2.2.2	Extractor fans – overall response time	
Para 10/2.3.1.1	Means to isolate smoke accumulators	
Para 11/2.1	Low-location lighting – approval	
Para 14/2.2.1.2	Medium expansion ratio foam – application rate, etc.	
Para 15/2.1.2	Inert gas systems – approval	
Para 15/2.2.4.6	Adequate reserve of water	
<b>2010 FTP Code</b>		
Para 4.2	Recognition of testing laboratories	
Para 5.1.1 and 5.1.2	Approval of products in accordance with established approval procedures or authorization of competent authorities to issue approvals	

<b>SPECIFIC FLAG STATE OBLIGATIONS</b>		
<b>SOURCE</b>	<b>SUMMARY DESCRIPTION</b>	<b>COMMENTS</b>
Para 5.2.2	Requirements for manufacturers – quality control system audited by a competent authority – or alternatively use of final product verification procedures as referred to in the paragraph	
Para 7.2	Use of equivalents and modern technology – communication of information to the Organization	
Annex 1, part 3/3.3	Structural core of a material other than steel or aluminium alloy – decision on limits for rise in temperature	
Annex 1, part 3 appendix 1, para 2.3.2.9	Insulation system of 'A' class door – approval to the same standard as the door	
<b>LSA Code</b>		
Para 1.2.3	Determine the period of acceptability of LSAs subject to deterioration with age	
Para 4.4.1.2	Endorsement of lifeboat affixed approval plate	
Para 4.5.4	Fixed two-way VHF radiotelephone apparatus – sheltered space	
Para 5.1.1.4	Rescue boats – combination of rigid and inflatable construction	
Para 5.1.3.8	Rubbing strips on inflated rescue boats	
Paras 6.1.2.9 and 6.1.2.10	Lowering speed of a fully equipped liferaft	
Para 6.2.1.2	MES – strength and construction of passage and platform	
Para 7.2.2.1	Broadcast of messages from other places on board	
<b>1994 HSC Code</b>		
Para 1.3.5	Verification	
Para 1.4.29	Determination of "maximum operational weight"	

<b>SPECIFIC FLAG STATE OBLIGATIONS</b>		
<b>SOURCE</b>	<b>SUMMARY DESCRIPTION</b>	<b>COMMENTS</b>
Para 1.5.1.2	Specifying intervals for renewal surveys	
Para 1.5.4	Inspection and survey	
Para 1.5.5	Recognized organizations and nominated surveyors	
Para 1.5.7	Completeness of survey and inspection	
Para 1.8.1	Issue/endorsement of certificate	
Para 1.9.2	Issue of permit to operate	
Para 1.11.2	Equivalentents – reporting	
Para 1.12.1	Adequate information and guidance provided to the craft by the company	
Paras 1.13.2 and 1.13.3	Novel designs	
Para 1.14.1	Investigation reports to IMO	
Paras 2.7.4 and 2.14.2	Inclining and stability information – approval	
Para 3.4	Determination of service life	
Para 3.5	Design criteria	
Para 4.8.3	Documentation and verification of evacuation time	
Para 7.5.6.3	Safe outlets for exhaust fans in fuel tank spaces	
Para 7.7.2.3.2	Sensitivity limits of smoke detectors	
Para 7.7.6.1.5	Additional quantity of fire-extinguishing medium	
Para 7.7.6.1.12	Containers for the storage of fire-extinguishing medium, etc. – design	
Para 7.7.8.5	Maximum length of fire hoses	
Para 8.1	Approval and acceptance of LSA and arrangements	



<b>SPECIFIC FLAG STATE OBLIGATIONS</b>		
<b>SOURCE</b>	<b>SUMMARY DESCRIPTION</b>	<b>COMMENTS</b>
Para 8.9.1.2	Approval of novel life-saving appliances or arrangements	
Para 8.9.1.3	Notification to the Organization	
Para 8.9.7.1.2	Approval of servicing stations	
Para 8.9.7.2	Deployment intervals of MES	
Para 8.9.11	Novel life-saving appliances or arrangements	
Para 8.9.12	Notification to the Organization	
Para 10.2.4.9	Flexible oil fuel pipes	
Para 10.3.7	Internal diameters of suction branches	
Para 12.6.2	Specified voltages to earth	
Para 13.1.2	Navigational equipment and its installation	
Para 13.13	Approval of systems, equipment and performance standards	
Para 14.3.3	Exemptions – reporting	
Para 14.13.1	Type approval	
Para 14.14.5	Ensuring maintenance	
Para 14.15	Radio personnel	
Para 14.16	Radio records	
Para 15.3.1	Operating station – field of vision	
Para 15.7.2	Ensuring clear view through windows	
Para 17.8	Acceleration and deceleration	
Para 18.1.4	Determining maximum allowable distance from a base port or place of refuge	
Para 18.2	Craft documentation	

<b>SPECIFIC FLAG STATE OBLIGATIONS</b>		
<b>SOURCE</b>	<b>SUMMARY DESCRIPTION</b>	<b>COMMENTS</b>
Paras 18.3.1 to 18.3.7 Chapter 19	Training and qualifications Inspection and maintenance requirements	
<b>2000 HSC Code</b>		
Para 1.3.7	Verification	
Para 1.4.37	Determination of "maximum operational weight"	
Para 1.5.1.2	Specifying intervals for renewal surveys	
Para 1.5.4	Inspection and survey	
Para 1.5.5	Recognized organizations and nominated surveyors	
Para 1.5.7	Completeness of survey and inspection	
Para 1.7.3	Investigation to determine the need of survey	
Para 1.8.1	Issue/endorsement of certificate	
Para 1.9.1.1.4	Transit voyage – satisfied with the arrangement	
Para 1.9.2	Issue of permit to operate	
Para 1.9.7	The worst intended conditions and the operational limitations	
Para 1.11.2	Equivalentents – reporting	
Para 1.12.1	Adequate information and guidance provided to the craft by the company	
Paras 1.13.2 and 1.13.3	Novel designs	
Para 1.14.1	Investigation reports to IMO	
Para 2.9.3	Verification of load line marks	
Paras 2.7.5 and 2.14.2	Inclining and stability information – approval	

<b>SPECIFIC FLAG STATE OBLIGATIONS</b>		
<b>SOURCE</b>	<b>SUMMARY DESCRIPTION</b>	<b>COMMENTS</b>
Para 3.4	Determination of service life	
Para 3.5	Design criteria	
Para 4.2.2	Approval of public address system	
Para 4.8.3	Documentation and verification of evacuation time	
Para 4.8.10	Evacuation demonstration	
Para 7.3.3	Approval of structural fire protection details	
Para 7.5.6.3	Safe outlets for exhaust fans in fuel tank spaces	
Para 7.7.1.1.8	Limitation of number of enclosed spaces in each section	
Para 7.7.1.3.2	Sensitivity limits of smoke detectors	
Para 7.7.3.3.6	Additional quantity of fire-extinguishing medium	
Para 7.17.1	Reduced requirements for cargo craft of less than 500 GT	
Para 7.17.3.1.5	Water spray system – approval	
Para 7.17.3.3	Smoke detection systems – equivalent protection	
Para 7.17.4	Issue of Document of Compliance for craft carrying dangerous goods	
Para 8.1	Approval and acceptance of LSA and arrangements	
Para 8.9.7.1.2	Approval of servicing stations	
Para 8.9.8	Rotational deployment of marine evacuation systems	
Para 8.9.11	Extension of liferaft service intervals – notification	
Para 8.11	Helicopter pick-up areas – approval	

<b>SPECIFIC FLAG STATE OBLIGATIONS</b>		
<b>SOURCE</b>	<b>SUMMARY DESCRIPTION</b>	<b>COMMENTS</b>
Para 10.2.4.9	Flexible oil fuel pipes	
Para 10.3.7	Internal diameters of suction branches	
Para 12.6.2	Specified voltages to earth	
Para 13.1.2	Shipborne navigational system and equipment and voyage data recorder and their installation	
Para 13.17	Type approval	
Para 14.3.3	Exemptions – reporting	
Para 14.4.2	GMDSS Identities – suitable arrangements	
Para 14.14.1	Type approval	
Para 14.15.5	Ensuring maintenance	
Para 14.16	Radio personnel	
Para 14.17	Radio records	
Para 15.3.1	Operating station – field of vision	
Para 15.7.2	Ensuring clear view through windows	
Para 17.8	Acceleration and deceleration	
Para 18.1.4	Determining maximum allowable distance from a base port or place of refuge	
Para 18.2	Craft documentation	
Paras 18.3.1 to 18.3.7	Training and qualifications	
Chapter 19	Inspection and maintenance requirements	

<b>SPECIFIC FLAG STATE OBLIGATIONS</b>		
<b>SOURCE</b>	<b>SUMMARY DESCRIPTION</b>	<b>COMMENTS</b>
<b>Res. A.744(18), as amended</b>	Guidelines on the enhanced programme of inspections during surveys of bulk carriers and oil tankers	
<b>Annex A – Bulk carriers</b>		
<b>Part A – Single-side skin bulk carriers</b>		
Para 1.3.1	Repair of damage affecting the ship's structural, watertight or weathertight integrity	
Para 1.3.2	Corrosion or structural defects impairing the ship's fitness	
Para 3.3.4	Repairs of cargo hatch securing system	
Para 5.1.1	Survey programme	
Para 5.1.4	Maximum acceptable structural corrosion diminution levels	
Para 5.2.1.1	Provisions for proper and safe access	
Para 6.2.2	Survey report file	
Para 8.1.2	Evaluation of survey report	
Para 8.2.3	Condition evaluation report	
Annex 4B, para 1	Survey planning questionnaire	
Annex 5, para 3.1	Certification of thickness measurement	
Annex 9, para 2.3	Technical assessment in conjunction with the planning of enhanced surveys for bulk carriers	
Annex 13, para 3	Cargo hatch cover securing arrangements	
<b>Part B – Double-side skin bulk carriers</b>		
Para 1.3.1	Repair of damage affecting the ship's structural, watertight or weathertight integrity	

<b>SPECIFIC FLAG STATE OBLIGATIONS</b>		
<b>SOURCE</b>	<b>SUMMARY DESCRIPTION</b>	<b>COMMENTS</b>
Para 1.3.2	Corrosion or structural defects impairing the ship's fitness	
Para 3.3.4	Cargo hatch cover securing system	
Para 5.1.1	Survey programme	
Para 5.1.5	Maximum acceptable structural corrosion diminution levels	
Para 5.2.2	Provisions for proper and safe access	
Para 6.2.2	Survey report file retained in the Administration	
Paras 8.1.2 and 8.2.3	Evaluation of survey report	
Annex 4B	Survey planning questionnaire	
Annex 5, para 3.1	Certification of a company engaged in thickness measurement	
Annex 9, para 2.3	Technical assessment in conjunction with the planning of enhanced surveys for bulk carriers	
Annex 11, para 3	Materials and welding	
<b>Annex B – Oil tankers</b>		
<b>Part A – Double hull oil tankers</b>		
Para 1.3.1	Repair of damage affecting the ship's structural, watertight or weathertight integrity	
Para 1.3.2	Corrosion or structural defects impairing the ship's fitness	
Para 2.4.3.2	Approval of corrosion prevention system	
Para 5.1.1	Survey programme	
Para 5.1.4	Maximum acceptable structural corrosion diminution levels	

<b>SPECIFIC FLAG STATE OBLIGATIONS</b>		
<b>SOURCE</b>	<b>SUMMARY DESCRIPTION</b>	<b>COMMENTS</b>
Para 5.2.1.1	Provisions for proper and safe access	
Para 6.2.2	Survey report file	
Para 8.1.3	Evaluation of survey report	
Para 8.2.3	Condition evaluation report	
Annex 6B	Survey planning questionnaire	
Annex 7, para 3.1	Certification of thickness measurement	
Annex 9	Diminution limits of structural members	
Annex 11, para 2.3	Technical assessment in conjunction with the planning of enhanced surveys for oil tankers	
Annex 12	Criteria for longitudinal strength of hull girder for oil tankers	
<b>Part B – Oil tankers other than double hull oil tankers</b>		
Para 1.3.1	Repair of damage affecting the ship's structural, watertight or weathertight integrity	
Para 1.3.2	Corrosion or structural defects impairing the ship's fitness	
Para 2.4.3.2	Approval of corrosion prevention system	
Para 5.1.1	Survey programme	
Para 5.1.4	Maximum acceptable structural corrosion diminution levels	
Para 5.2.1.1	Provisions for proper and safe access	
Para 6.2.2	Survey report file	
Para 8.1.3	Evaluation of survey report	
Para 8.2.3	Condition evaluation report	
Annex 6B	Survey planning questionnaire	

<b>SPECIFIC FLAG STATE OBLIGATIONS</b>		
<b>SOURCE</b>	<b>SUMMARY DESCRIPTION</b>	<b>COMMENTS</b>
Annex 7, para 3.1 Annex 9 Annex 11, para 2.3 Annex 12	Certification of thickness measurement Diminution limits of structural members Technical assessment in conjunction with the planning of enhanced surveys for oil tankers Criteria for longitudinal strength of hull girder for oil tankers	
<b>Res. 4 of the 1997 SOLAS Conference</b> Section 5	Dimension and selection of weld connections and materials	
<b>Res. MSC.168(79)</b> Para 2.1 Para 4.4 Para 4.5	Standards and criteria for side structures of bulk carriers of single-side skin construction Applicable national standards Applicable national standards Applicable national standards	
<b>NO<sub>x</sub> Technical Code 2008</b> Chapter 1 Chapter 2 Chapter 2 para 2.2.5.1 Chapter 3	Assumption of full responsibility for the approval of documentation as required by the Code together with the acceptance of procedures and alternatives as permitted by the Code Issue of the Engine International Air Pollution Prevention Certificate, arrangements for the Parent Engine test and pre-certification of engines, usage of the Engine Family/Engine Group concepts and approval of the Technical File and any subsequent amendments Approval and pre-certification in the case referred to in the paragraph Acceptance of modification of engine speed at E2 test cycle 25% power mode point	



<b>SPECIFIC FLAG STATE OBLIGATIONS</b>		
<b>SOURCE</b>	<b>SUMMARY DESCRIPTION</b>	<b>COMMENTS</b>
Chapter 4	Assignment of Engine Family/Engine Group status, as applicable, and selection of associated Parent Engine. Acceptance of conformity of production arrangements. Adjustment of Parent Engine relative to Engine Group reference values	
Chapter 5	Ensuring that the Parent Engine test and subsequent calculations are undertaken in accordance with Code requirements and that, where alternatives are applied, these meet the Code's equivalency requirements and any deviations are within the permitted margins. Filing of Parent Engine test report	
Chapter 6	Onboard NO <sub>x</sub> Verification Procedures are in accordance with the provisions of the Code and are adequate to provide verification that an engine, as so surveyed, will be in accordance with the applicable Annex VI requirements. Acceptance of aspects within Onboard NO <sub>x</sub> Verification Procedure – Simplified Measurement Method if applicable. Approval of aspects within Onboard NO <sub>x</sub> Verification Procedure – Direct Measurement and Monitoring Method including the Onboard Monitoring Manual, if applicable	
Chapter 7	Installation of Approved method – amendment of IAPP Certificate	
Appendix IV	Verification that the calibration of all necessary measurement equipment meets Code requirements	
Appendix VII	Aspects to be included within Onboard NO <sub>x</sub> Verification Procedure – Parameter Check Method	
Appendix VIII	Approval of alternative exhaust gas measurement principles	

<b>SPECIFIC FLAG STATE OBLIGATIONS</b>		
<b>SOURCE</b>	<b>SUMMARY DESCRIPTION</b>	<b>COMMENTS</b>
<b>IBC CODE</b>		
Para 1.1.6	Prescribe preliminary suitable conditions for carriage of products not listed in chapter 17 or 18	
Para 1.4.2	Equivalents – communication to IMO	
Section 1.5	Survey and certification	
Para 2.2.2	Intact stability in all seagoing conditions	
Para 2.2.3	Free surface effect in undamaged compartments	
Para 2.4	Conditions of loading	
Para 2.8.1.6	Standard of damage	
Para 2.8.2	Standard of damage – alternative measures	
Para 2.9.2.3	Residual stability during intermediate stages of flooding	
Para 3.4.4	Access to spaces in the cargo area	
Para 3.7.3.5	Alternative arrangements for draining the piping	
Para 3.7.4	Relaxation for small ships	
Para 5.1.6.4	Dimensions for flanges not complying with the standards	
Para 5.2.2	Piping fabrication and joining details	
Para 7.1.1	Cargo temperature control – general	
Para 8.3.6	Devices to prevent the passage of flames into cargo tanks – requirements for the design, testing and locating	
Para 10.1.3	Electrical installations – appropriate steps for uniform implementation	
Para 10.1.4	Electric equipment, cables and wiring which do not conform to the standard	

<b>SPECIFIC FLAG STATE OBLIGATIONS</b>		
<b>SOURCE</b>	<b>SUMMARY DESCRIPTION</b>	<b>COMMENTS</b>
Para 10.1.5	Electrical equipment in hazardous locations	
Para 11.2.2	Approval of an appropriate fire-extinguishing system	
Para 11.3.2	Cargo area – additional arrangements	
Para 11.3.5.3	Cargo area – minimum capacity of monitor	
Para 11.3.7	Minimum capacity of foam monitor for ships less than 4,000 tonnes deadweight	
Para 11.3.13	Alternative provisions to deck foam system	
Para 13.2.3	Exemption of toxic vapour detection equipment	
Para 14.1.2	Protective equipment	
Chapter 15	Approval of special requirements for specific chemicals	
Para 16.2.2	Cargo information – independent expert	
Para 16.5.1	Stowage of cargo samples – approval	
Para 18.2	Safety requirements – list of products to which the Code does not apply	
<b>BCH CODE</b>		
Para 1.5.2	Equivalent – communication to IMO	
Section 1.6	Survey requirements	
Section 1.8	New products – establishing suitable conditions – notification to IMO	
Para 2.2.4	Determination of the ability to survive flooding of the machinery space in Type 3 below 125 m in length	
Para 2.2.5	Nature of alternative measures prescribed for small ships – duly noted on certificate	

<b>SPECIFIC FLAG STATE OBLIGATIONS</b>		
<b>SOURCE</b>	<b>SUMMARY DESCRIPTION</b>	<b>COMMENTS</b>
Para 2.9.5 Section 2.10	Access to void spaces, cargo tanks, etc. – approval of smaller dimensions in special circumstances Cargo piping systems – setting standards	
Section 2.12 Para 2.14.2 Para 2.15.1 Para 3.1.2(f) Para 3.14.1 Para 3.14.2 Para 3.14.7 Para 3.15.2 Para 3.15.5 Chapter IV	Cargo hoses – setting standards High-velocity vent valves – type approval Cargo heating and cooling systems Ventilation fans – approval Alternative provisions for ships dedicated to the carriage of specific cargoes Additional arrangements when foam is not effective or is incompatible Foam monitors on ships of less than 4,000 tonnes deadweight – minimum capacity Protection of cargo pump-rooms with fire-extinguishing systems – approval Products evolving flammable vapours – fire-extinguishing systems – approval Approval of special requirements for specific chemicals	
<b>IGC CODE</b> Para 1.1.6 Para 1.4.2 Section 1.5 Para 2.2.2 Para 2.2.3 Para 2.3.3 Para 2.4	Establishment of preliminary suitable conditions of carriage and notification Equivalentents – reporting Surveys and certification Stability standard – acceptance Method to calculate free surface effect – acceptance Automatic non-return valves – acceptance Damage survival capability investigation	

<b>SPECIFIC FLAG STATE OBLIGATIONS</b>		
<b>SOURCE</b>	<b>SUMMARY DESCRIPTION</b>	<b>COMMENTS</b>
Para 2.8.2	Alternative measures – approval	
Para 2.9.1.3	Residual stability during intermediate stages of flooding	
Para 3.5.3.2	Decreased clear opening in the cargo area	
Section 3.8	Bow or stern loading and unloading arrangements – approval	
Para 4.2.7	Design temperature	
Paras 4.4.2.5 and 4.4.4.1	Structural analysis of the hull	
Paras 4.4.6.1.1, 4.4.6.2.1 and 4.4.6.3.2	Setting standards	
Para 4.4.7.2.1	Three-dimensional structural analysis	
Para 4.4.7.3	Analysis	
Para 4.5.1.11	Allowable stresses – approval	
Para 4.7.3	Secondary barriers for non-basic tank types	
Para 4.7.7	Checking method – approval	
Para 4.8.4.4	Design and construction of the heating system	
Para 4.9.8	Insulation materials	
Para 4.10.1.2.2	Bevel preparation, etc. – acceptance and approval	
Para 4.10.2	Workmanship	
Para 4.10.5.2	Quality control specifications	
Para 4.10.6	Integral tank-testing	
Para 4.10.8.3	Tightness test	
Para 4.10.9	Type C independent tanks – inspection and NDT	
Para 4.10.10.3.7	Consideration of pneumatic testing	

<b>SPECIFIC FLAG STATE OBLIGATIONS</b>		
<b>SOURCE</b>	<b>SUMMARY DESCRIPTION</b>	<b>COMMENTS</b>
Para 4.11.1	Soaking temperature and holding times	
Para 4.11.2	Alternative to heat treatment – approval	
Paras 5.2.4.4 and 5.2.4.5	Flanges, valves and other fittings	
Para 5.4.2.2	Dimensions	
Para 5.4.2.3	Screwed couplings – acceptance	
Para 5.5.2	Cargo and process piping – alternative testing approval	
Para 6.1.5	Tensile strength, yield stress and elongation	
Para 6.3.7.4	Schedule for inspection and NDT	
Section 7.1	Cargo pressure/temperature control	
Paras 8.2.2, 8.2.5 and 8.2.7	Pressure relief devices	
Para 9.5.2	A means of preventing the backflow of cargo	
Para 10.1.5	Electrical equipment installation	
Para 11.4.1	Dry chemical powder fire-extinguishing system	
Para 11.5.2	Approval of appropriate fire-extinguishing system for cargo compressor and pump-rooms	
Para 13.5.4	Number and position of temperature indicating devices	
Para 13.6.1	Gas detector equipment	
Para 13.6.13	Portable gas detection equipment	
Para 14.4.5	Provision of space to protect personnel	
Section 15.2	Maximum allowable loading limits – approval of list	
Para 16.5.2	Forced draught system for boilers	
Para 16.5.6	Purging of combustion chambers of boilers	

<b>SPECIFIC FLAG STATE OBLIGATIONS</b>		
<b>SOURCE</b>	<b>SUMMARY DESCRIPTION</b>	<b>COMMENTS</b>
Para 17.14.2.1	Non-acceptance of cargo discharge compressors on board	
Para 17.20.3.1	Valves, flanges, fittings and accessory equipment material – acceptance	
Para 17.20.13.2	Cargo handling plans – approval	
Para 17.20.14	Maximum allowable tank filling limits – approval of list	
<b>STCW Code, part A</b>		
Section A-I/10.2	Withdrawal of endorsement of recognition – communication to the Party that issued the certificate	
Section A-II/4.4	Determining the requirements of training, assessment and certification where there are no tables of competence for the support level	
Section A-III/4.4	Determining the requirements of training, assessment and certification where there are no tables of competence – for the support level	
Section A-VIII/1.1	Fitness of duty – consideration of the danger posed by fatigue of seafarers	
Section A-VIII/1.5	Requirements of watch schedules to be posted in a standardized form	
Section A-VIII/1.7	Requirements of maintaining records of daily hours of rest of seafarers	
Section A-VIII/1.10	Establishment of a limit of alcohol concentration for personnel performing designated duties	
Section A-VIII/2.84	Principles to be observed in keeping radio watch – directing the attention of companies, masters, radio watchkeeping personnel to comply with provisions in part 4-3 to ensure that and adequate safety radio watch is maintained when the ship is at sea	

<b>SPECIFIC FLAG STATE OBLIGATIONS</b>		
<b>SOURCE</b>	<b>SUMMARY DESCRIPTION</b>	<b>COMMENTS</b>
<b>Res. MEPC.94(46), as amended</b>	Condition assessment scheme	
Para 4.1	Issue instructions to the recognized organization (RO) for Condition Assessment Scheme (CAS) survey	
Para 4.3	Require oil tankers to remain out of service until Statement of Compliance is issued	
Para 7.1.3	CAS surveyors' requirements	
Para 11	Verification of CAS	
Para 12	Reassessment of ships that have failed	
Para 13	Issue, suspension or withdrawal of Statement of Compliance	
Para 14	Communication to IMO	
<b>Res. MSC.215(82)</b>	Performance standard for protective coatings for dedicated seawater ballast tanks in all types of ships and double-side skin spaces of bulk carriers	
Para 3.2	Inspection of surface preparation and coating processes	
Para 3.4.1	Coating technical file	
Para 4.4.3	The Technical Data Sheet and Statement of Compliance or Type Approval Certificate – verification	
Section 5	Coating system approval	
Para 6.1.1	Verification of equivalent qualification of coating inspector	
Section 7	Verification requirements	



<b>SPECIFIC FLAG STATE OBLIGATIONS</b>		
<b>SOURCE</b>	<b>SUMMARY DESCRIPTION</b>	<b>COMMENTS</b>
<p><b>Res. MSC.288(87)</b></p> <p>Para 3.2</p> <p>Para 4.6.3</p> <p>Para 6.1.1</p> <p>Para 7</p>	<p>Performance standard for protective coatings for cargo oil tanks of crude oil tankers</p> <p>Inspection of surface preparation and coating processes – review</p> <p>Verification of the Technical Data Sheet and Statement of Compliance or Type Approval Certificate for the protective coating system</p> <p>Equivalent to NACE Coating Inspector Level 2 and FROSIO Inspector Level III – verification</p> <p>Coating verification requirement as referred to in paragraph 7</p>	
<p><b>Res. MSC.289(87)</b></p> <p>Para 2.2</p> <p>Para 4.2</p> <p>Para 5</p>	<p>Performance standard for alternative means of corrosion protection for cargo oil tanks of crude oil tankers</p> <p>Verification of Technical File</p> <p>Issuance of Type Approval Certificate for corrosion resistant steel</p> <p>Survey(s) during the construction process to verify that approved corrosion-resistant steel has been applied to the area required</p>	
<p><b>Casualty Investigation Code</b></p> <p>Para 1/1.3</p> <p>Para 6/6.2</p>	<p>Qualified person (s) for investigation</p> <p>Investigation into a very serious marine casualty</p>	
<p><b>IS Code, 2008</b></p> <p>Part A, Ch. 1.2</p> <p>Part A, Ch. 2.1.3</p> <p>Part A, Ch. 2.3</p> <p>Part A, Ch. 3</p>	<p>International Code on Intact Stability, 2008</p> <p>Criteria demonstrating sufficient ship stability in critical stability situation in waves</p> <p>Stability criteria where anti-rolling devices are installed</p> <p>Severe wind and stability criterion</p> <p>Special criteria for certain types of ships</p>	

<b>SPECIFIC FLAG STATE OBLIGATIONS</b>		
<b>SOURCE</b>	<b>SUMMARY DESCRIPTION</b>	<b>COMMENTS</b>
<b>IMSBC Code</b>	International Maritime Solid Bulk Cargoes Code	
Section 1.3	Conditions for the carriage of cargoes not listed in the Code	
Section 1.5	Exemptions	
Para. 7.3.2.2	Approval of specially constructed cargo ships	
Para. 7.3.2.3	Approval of plan of special arrangements and details of the stability conditions on which the design has been based	
Appendix 1, Schedule for Aluminium Ferrosilicon Powder, UN 1395 and Aluminium Silicon Powder, Uncoated, UN 1398	Inspection and approval of gastight bulkheads between cargo spaces and engine-room	
Appendix 1, Schedule for Ferrosilicon, UN 1408, and Ferrosilicon	Inspection and approval of gastight bulkheads between cargo spaces and engine-room and approval of safety of bilge pumping arrangement	

\* \* \*

ANNEX 3

**SPECIFIC COASTAL STATE OBLIGATIONS**

The following table contains a non-exhaustive list of obligations, including those obligations imposed when a right is exercised.

<b>SPECIFIC COASTAL STATE OBLIGATIONS</b>		
<b>SOURCE</b>	<b>SUMMARY DESCRIPTION</b>	<b>COMMENTS</b>
<b>SOLAS 74</b>		
Reg. V/4	Navigation warnings	
Reg. V/7.1	Search and rescue services – necessary arrangements	
Reg. V/7.2	Search and rescue services – information to IMO	
Reg. V/8	Life-saving signals	
Reg. V/9	Hydrographic services	
Reg. VII/6.1 and 7-4.1	Reporting of incidents involving dangerous goods	
<b>MARPOL</b>		
<b>Annex I</b>		
Reg. 4.3	Exceptions – discharge of substances containing oil for the purpose of combating pollution incidents	
<b>Annex II</b>		
Reg. 3.1.3	Exceptions – approval of discharge of NLS for the purpose of combating pollution incidents	
Reg. 13.2.3	Control of discharges of residues of NLS – agreement and communication to IMO	

\* \* \*

ANNEX 4

**SPECIFIC PORT STATE OBLIGATIONS**

The following table contains a non-exhaustive list of obligations, including those obligations imposed when a right is exercised.

<b>SPECIFIC PORT STATE OBLIGATIONS</b>		
<b>SOURCE</b>	<b>SUMMARY DESCRIPTION</b>	<b>COMMENTS</b>
<b>TONNAGE 69</b>		
Art. 12	Inspection	
<b>LL 66 AND LL PROT 88</b>		
Art. 21	Control	amended by LL PROT 88
<b>STCW 78</b>		
Art. X	Control	
Reg. I/4	Control procedures	
<b>SOLAS 74</b>		
Reg. I/6(c)	Ships not allowed to sail	
Reg. I/19	Control	
Reg. VII/7-2.2	Documents relating to carriage of dangerous goods in solid form	
Reg. VIII/11	Special control for nuclear ships	
Reg. XI-1/4	Port State control on operational requirements	
<b>MARPOL</b>		
Art. 5(2)	Certificates and special rules on inspection of ships – port State control	
Art. 5(3)	Certificates and special rules on inspection of ships – denial of entry	
Art. 6(2)	Detection of violations and enforcement of the Convention – inspection	

<b>SPECIFIC PORT STATE OBLIGATIONS</b>		
<b>SOURCE</b>	<b>SUMMARY DESCRIPTION</b>	<b>COMMENTS</b>
Art. 6(5)	Detection of violations and enforcement of the Convention – inspection upon request – reporting	
<b>Annex I</b>		
Reg. 2.6.2	Application – an oil tanker delivered on or before 1 June 1982 engaged in specific trades: agreement with flag States	
Reg. 2.6.3	Application – an oil tanker delivered on or before 1 June 1982, engaged in specific trades: approval by port States	
Reg. 11	Port State control on operational requirements	
Reg. 17.7	Oil Record Book, Part I – inspection without undue delay	
Reg. 18.10.1.2	Segregated ballast tanks – oil tanker delivered on or before 1 June 1982 having special ballast arrangements: agreement with flag States	
Reg. 20.8.2	Denial of entry – communication to IMO	
Reg. 21.8.2	Denial of entry – communication to IMO	
Reg. 36.8	Oil Record Book, Part II – inspection without undue delay	
Reg. 38.1, 38.2 and 38.3	Reception facilities outside special areas	
Reg. 38.4 and 38.5	Reception facilities within special areas	
Reg. 38.6	Reception facilities within special areas – notification to IMO	
Reg. 38.7.1	Reception facilities within special areas: "Antarctic area"	
<b>Annex II</b>		
Reg. 4.3.3	Exemptions – approval of adequacy of reception facilities	
Reg. 13.6.1	Control of discharges of residues – endorsement of cargo record book	
Reg. 15.6	Cargo record book – inspection without undue delay	

<b>SPECIFIC PORT STATE OBLIGATIONS</b>		
<b>SOURCE</b>	<b>SUMMARY DESCRIPTION</b>	<b>COMMENTS</b>
Reg. 16.1	Measures of control	
Reg. 16.6 and 16.7	Measures of control – exemption granted (endorsement of cargo record book)	
Reg. 16.9	Port State control on operational requirement	
Reg. 18.1 and 18.2	Reception facilities and cargo unloading terminal arrangements	
Reg. 18.4	Cargo unloading terminal arrangements	
<b>Annex III</b>		
Reg. 8	Port State control on operational requirements	
<b>Annex IV</b>		
Reg.12.1	Provision of reception facilities	
Reg.12bis.1	Provision of reception facilities for passenger ships in special areas	
Reg.12bis.2	Measures taken regarding reception facilities for passenger ships in Special Areas – notification to the Organization	
Reg. 13	Port State control on operational requirements	
<b>Annex V</b>		
Reg. 6.3.1	Provision of reception facilities – all garbage from all ships departing on route or arriving from the Antarctic area	
Reg. 8.1	Reception facilities	
Reg. 8.3.1	Reception facilities within special areas	
Reg. 8.3.2	Measures taken regarding provision of reception facilities – notification to the Organization	
Reg. 9	Port State control on operational requirements	
Reg.10.5	Inspection of Garbage Record Book or ship's official logbook	

<b>SPECIFIC PORT STATE OBLIGATIONS</b>		
<b>SOURCE</b>	<b>SUMMARY DESCRIPTION</b>	<b>COMMENTS</b>
<b>Annex VI</b>		
Reg. 5.3.3	Necessary assistance to the surveyor as referred to in the paragraph	
Reg. 10	Port State control on operational requirements – for chapter 4, limitation to verification of the availability of a valid International Energy Efficiency Certificate on board	
Reg. 15.2 and 15.3	Volatile organic compounds – approvals of vapour emission control systems and notification to IMO	
Reg. 17.2	Reception facilities as referred to in the paragraph – communication to IMO	
Reg. 18.10	Fuel oil quality – Communication to Party or non-Parties and remedial action	
<b>IBC Code</b>		
Para 15.8.25.3	Certification verifying that the required piping separation	
<b>1994 HSC Code</b>		
Para 1.3.5	Acceptance of the Code	
Para 1.5.6	Provide assistance for surveyors	
Para 1.6	Design approval	
Para 1.9.3	Operational conditions – Permit to Operate	
Para 1.9.4	Port State control	
Para 18.3.8	Training and qualifications	
<b>2000 HSC Code</b>		
Para 1.3.7	Acceptance of the Code	
Para 1.5.6	Provide assistance for surveyors	
Para 1.6	Design approval	
Para 1.9.3	Operational conditions – Permit to Operate	
Para 1.9.4	Port State control	
Para 18.3.8	Training and qualifications	

<b>SPECIFIC PORT STATE OBLIGATIONS</b>		
<b>SOURCE</b>	<b>SUMMARY DESCRIPTION</b>	<b>COMMENTS</b>
<b>GRAIN Code</b>		
Para 3.4	Document of authorization	
Para 3.5	Document of authorization	
Para 5	Exemptions for certain voyages	
Para 7.2	Stability requirements	
<b>IMSBC Code</b>	International Maritime Solid Bulk Cargoes Code	
Section 1.3	Conditions for the carriage of cargoes not listed in the Code	
Section 1.5	Exemptions	

\* \* \*



ANNEX 5

**INSTRUMENTS MADE MANDATORY UNDER IMO CONVENTIONS**

<b>SOLAS 74</b>	Res. MSC.215(82)	reg. II-1/3-2.2
	Res. MSC.133(76), as amended	reg. II-1/3-6.2.1
	Res. MSC.287(87)	reg. II-1/3-10.3
	Res. MSC.288(87)	reg. II-1/3-11.1
	Res. MSC.289(87)	reg. II-1/3-11.2
	2008 IS Code, part A	reg. II-1/5.1
	FSS Code	reg. II-2/3.22
	2010 FTP Code	reg. II-2/3.23
	LSA Code	reg. III/3.10
	IMSBC Code	reg. VI/1-2
	CSS Code, sub-chapter 1.9	reg. VI/2.1
	Grain Code	reg. VI/8.1
	IMDG Code	reg. VII/1.1
	IBC Code	reg. VII/8.1
	IGC Code	reg. VII/11.1
	INF Code	reg. VII/14.1
	ISM Code	reg. IX/1.1
	1994 HSC Code	reg. X/1.1
	2000 HSC Code	reg. X/1.2
	Res. A.739(18), as amended	reg. XI-1/1
	Res. A.789(19)	reg. XI-1/1
	Res. A.744(18), as amended	reg. XI-1/2
	Casualty Investigation Code, parts I and II	reg. XI-1/6
Res. 4 of the 1997 SOLAS Conf.	reg. XII/1.7	
Res. MSC.169(79)	reg. XII/7.2	
Res. MSC.168(79)	reg. XII/14	
<b>MARPOL</b>	Res. MEPC.94(46), as amended	Annex I, reg. 20.6
	IBC Code	Annex II, reg. 1.4
	BCH Code	Annex II, reg. 1.4
	NO <sub>x</sub> Technical Code 2008	Annex VI, reg. 5.3.2
<b>STCW 78</b>	STCW Code, part A	reg. I/1.2.3
<b>LL PROT 1988</b>	2008 IS Code	Annex 1, reg. 1

\* \* \*

ANNEX 6

**SUMMARY OF AMENDMENTS TO MANDATORY INSTRUMENTS  
REFLECTED IN THE NON-EXHAUSTIVE LIST OF OBLIGATIONS  
(ANNEXES 1 TO 4)**

The amendments to mandatory instruments reflected in annexes 1 to 4 are summarized below to facilitate the amendment of corresponding tables in the future.

SOLAS 1974	up to and including 2011 amendments (res. MSC.317(89)), except chapter XI-2, regulation V/19-1 and ISPS Code)
Res. MSC.215(82)	as adopted
Res. MSC.133(76), as amended	up to and including the 2004 amendments (res. MSC.158(78))
Res. MSC.287(87)	as adopted
Res. MSC.288(87)	as adopted
Res. MSC.289(87)	as adopted
2008 IS Code	Up to res. MSC.319(89)(part B only)
FSS Code	up to and including the 2011 amendments (res. MSC.311(88))
2010 FTP Code	up to and including the 2010 amendments (res. MSC.307(88))
LSA Code	Up to res. MSC.320(89)
IMSBC Code	up to and including the 2011 amendments (res. MSC. 318(89))
CSS Code, sub-chapter 1.9	up to and including the 2002 amendments (MSC/Circ.1026)
GRAIN Code	up to and including the 1991 amendments (res. MSC.23(59))
IMDG Code	up to and including the 2010 amendments (res. MSC. 294(87))
IBC Code	up to and including the 2006 amendments (res. MSC.219(82) and res. MEPC.166(56))
IGC Code	up to and including the 2006 amendments (res. MSC.220(82))
INF Code	up to and including the 2007 amendments (res. MSC.241(83))
ISM Code	up to and including the 2008 amendments (res. MSC.273(85))
1994 HSC Code	up to and including the 2008 amendments (res. MSC.259(84))
2000 HSC Code	up to and including the 2008 amendments (res. MSC.271(85))
Res. A.739(18)	up to and including 2006 amendments (res. MSC.208(81))
Res. A.789(19)	no amendments yet adopted

Res. A.744(18), amended	up to and including the 2008 amendments (res. MSC.261(84))
Casualty Investigation Code	res. MSC.255(84)
Res. 4 of the 1997 SOLAS Conf.	no amendments yet adopted
Res. MSC.169(79)	no amendments yet adopted
Res. MSC.168(79)	no amendments yet adopted
SOLAS PROT 1978	up to and including the 1988 amendments (resolution of the 1988 GMDSS-P Conference)
SOLAS PROT 1988	up to and including the 2010 amendments (res. MSC.309 (88))
MARPOL	up to and including the 2012 (res. MEPC.217(63)) amendments
Res. MEPC.94(46), as amended	up to and including the 2006 amendments (res. MEPC.155(55))
IBC Code	up to and including the 2006 amendments (res. MEPC.166(56) and res. MSC.219(82))
BCH Code	up to and including the 2006 amendments (res. MEPC.144(54) and res. MSC.212(81))
NO <sub>x</sub> Technical Code 2008	up to and including the 2012 amendments (res. MEPC. 217(63))
STCW 1978	up to and including the Manila amendments (STCW/Conf.2/res.1), except regulations VI/5.2, 6.3 and 6.6
STCW Code, part A	up to and including the Manila amendments (STCW/Conf.2/res.2)
LL 1966	up to and including the 2005 amendments (res. A.972(24))
LL PROT 1988	up to and including the 2008 amendments (res. MSC.270(85))
TONNAGE 1969	no amendments yet adopted
COLREG 1972	up to and including the 2001 amendments (res. A.910(22))

\* \* \*

ANNEX 7

**AMENDMENTS<sup>3</sup> TO IMO INSTRUMENTS EXPECTED TO BE ACCEPTED  
AND TO ENTER INTO FORCE BETWEEN 1 JANUARY 2014 AND 1 JULY 2014**

The following tables contain non-exhaustive lists of obligations, including those obligations imposed when a right is exercised.

<b>OBLIGATIONS OF CONTRACTING GOVERNMENTS/PARTIES</b>		
<b>SOURCE</b>	<b>SUMMARY DESCRIPTION</b>	<b>COMMENTS</b>
<b>MARPOL</b> <u>Annex III, reg. 1.3</u>	<u>Application – issue detailed requirements on packing, marking, labelling, documentation, stowage, quantity limitations and exceptions for preventing or minimizing pollution of the marine environment by harmful substances</u>	<u>In force 1.1.2014 by MEPC.193(61)</u>
<b>IMDG Code</b>		
<u>Ch 3.3 SP356</u>	<u>Approval of metal hydride storage systems installed in vehicles, vessels or aircrafts or in completed components or intended to be installed in vehicles, vessels or aircrafts</u>	<u>In force 1/1/2014 by MSC.328(90)</u>
<u>Section 5.4.1</u>	<u>Information required in addition to the dangerous goods description – role of the competent authority</u>	<u>In force 1/1/2014 by MSC.328(90)</u>
<u>Section 6.2.3</u>	<u>The marking of salvage pressure receptacles – determination by the competent authority</u>	<u>In force 1/1/2014 by MSC.328(90)</u>
<u>Section 7.1.44</u> <u>7.1.4.5</u>	<u>Stowage of goods of class 7 – role of competent authority</u>	<u>In force 1/1/2014 by MSC.328(90)</u>

<sup>3</sup> The struck-out text indicates deletions and the underlined text shows additions or changes, to the non-exhaustive list of obligations.

<b>SPECIFIC FLAG STATE OBLIGATIONS</b>		
<b>SOURCE</b>	<b>SUMMARY DESCRIPTION</b>	<b>COMMENTS</b>
<b>SOLAS</b> <u>Reg. V/14.2</u>	<u>Establishing appropriate minimum safe manning following a transparent procedure and issuing an appropriate minimum safe manning document or equivalent</u>	<u>In force 1/1/2014 by MSC.325(90)</u>
<b><u>2011 ESP Code<sup>4</sup></u></b> <b><u>Annex A, part A</u></b> <u>3.3.4</u>	<u>Supervision on repair of cargo hatch securing system</u>	<u>In force 1/1/2014 by A.1049(27)</u>
<u>5.1.1</u>	<u>Cooperation on development of a specific survey programme</u>	<u>In force 1/1/2014 by A.1049(27)</u>
<u>5.1.4</u>	<u>Advice on the maximum acceptable structural diminution levels</u>	<u>In force 1/1/2014 by A.1049(27)</u>
<u>5.2.2</u>	<u>Agreement on provisions for proper and safe access</u>	<u>In force 1/1/2014 by A.1049(27)</u>
<u>8.1.2</u>	<u>Evaluation of survey report</u>	<u>In force 1/1/2014 by A.1049(27)</u>
<u>8.2.3</u>	<u>Endorsement on condition evaluation report</u>	<u>In force 1/1/2014 by A.1049(27)</u>
<u>Annex 4B, para 1</u>	<u>Cooperation on development of a survey programme</u>	<u>In force 1/1/2014 by A.1049(27)</u>
<u>Annex 5, para 3.1</u>	<u>Certification of a company engaged in thickness measurement</u>	<u>In force 1/1/2014 by A.1049(27)</u>
<b><u>Annex A, part B</u></b> <u>3.3.4</u>	<u>Supervision on repair of cargo hatch securing system</u>	<u>In force 1/1/2014 by A.1049(27)</u>
<u>5.1.1</u>	<u>Cooperation on development of a specific survey programme</u>	<u>In force 1/1/2014 by A.1049(27)</u>
<u>5.1.4</u>	<u>Advice on the maximum acceptable structural diminution levels</u>	<u>In force 1/1/2014 by A.1049(27)</u>
<u>5.2.2</u>	<u>Agreement on provisions for proper and safe access</u>	<u>In force 1/1/2014 by A.1049(27)</u>

<sup>4</sup> All items under resolution A.744(18) are deleted.

<b>SPECIFIC FLAG STATE OBLIGATIONS</b>		
<b>SOURCE</b>	<b>SUMMARY DESCRIPTION</b>	<b>COMMENTS</b>
<u>8.1.2</u>	<u>Evaluation of survey report</u>	<u>In force 1/1/2014 by A.1049(27)</u>
<u>8.2.3</u>	<u>Endorsement on condition evaluation report</u>	<u>In force 1/1/2014 by A.1049(27)</u>
<u>Annex 4B, para 1</u>	<u>Cooperation on development of a survey programme</u>	<u>In force 1/1/2014 by A.1049(27)</u>
<u>Annex 5, para 3.1</u>	<u>Certification of a company engaged in thickness measurement</u>	<u>In force 1/1/2014 by A.1049(27)</u>
<b><u>Annex B, part A</u></b>		
<u>5.1.1</u>	<u>Cooperation on development of a specific survey programme</u>	<u>In force 1/1/2014 by A.1049(27)</u>
<u>5.1.4</u>	<u>Advice on the maximum acceptable structural diminution levels</u>	<u>In force 1/1/2014 by A.1049(27)</u>
<u>5.2.1.1</u>	<u>Agreement on provisions for proper and safe access</u>	<u>In force 1/1/2014 by A.1049(27)</u>
<u>8.1.3</u>	<u>Evaluation of survey report</u>	<u>In force 1/1/2014 by A.1049(27)</u>
<u>8.2.3</u>	<u>Endorsement on condition evaluation report</u>	<u>In force 1/1/2014 by A.1049(27)</u>
<u>Annex 6B</u>	<u>Cooperation on development of a survey programme</u>	<u>In force 1/1/2014 by A.1049(27)</u>
<u>Annex 7, para 3.1</u>	<u>Certification of a company engaged in thickness measurement</u>	<u>In force 1/1/2014 by A.1049(27)</u>
<b><u>Annex B, part B</u></b>		
<u>5.1.1</u>	<u>Cooperation on development of a specific survey programme</u>	<u>In force 1/1/2014 by A.1049(27)</u>
<u>5.1.4</u>	<u>Advice on the maximum acceptable structural diminution levels</u>	<u>In force 1/1/2014 by A.1049(27)</u>
<u>5.2.1.1</u>	<u>Agreement on provisions for proper and safe access</u>	<u>In force 1/1/2014 by A.1049(27)</u>
<u>8.1.3</u>	<u>Evaluation of survey report</u>	<u>In force 1/1/2014 by A.1049(27)</u>
<u>8.2.3</u>	<u>Endorsement on condition evaluation report</u>	<u>In force 1/1/2014 by A.1049(27)</u>

<b>SPECIFIC FLAG STATE OBLIGATIONS</b>		
<b>SOURCE</b>	<b>SUMMARY DESCRIPTION</b>	<b>COMMENTS</b>
<u>Annex 6B</u>	<u>Cooperation on development of a survey programme</u>	<u>In force 1/1/2014 by A.1049(27)</u>
<u>Annex 7, para 3.1</u>	<u>Certification of a company engaged in thickness measurement</u>	<u>In force 1/1/2014 by A.1049(27)</u>
<b>FSS Code</b>		
<u>Para 6/3.1.2</u>	<u>Foam concentrates of high-expansion foam fire-extinguishing systems – approval</u>	<u>In force 1/1/2014 by MSC.327(90)</u>
<u>Para 6/4.1</u>	<u>Foam concentrates of low-expansion foam fire-extinguishing systems – approval</u>	<u>In force 1/1/2014 by MSC.327(90)</u>
<u>Para 5/2.54</u>	Equivalent systems – approval	In force 1/7/2014 by MSC.339(91)
<u>Para 7/2.4</u>	<u>Fixed water-based fire-fighting system for ro-ro spaces, vehicle spaces and special category spaces – approval</u>	<u>In force 1/7/2014 by MSC.339(91)</u>
<u>Para 14/2.2.1.2</u>	<u>Medium expansion ratio foam — application rate, etc.</u>	Chapter 14 replaced by MSC.339(91)
<u>Para 14/2.2.1.4</u>	<u>Foam concentrate supplied on board for cargoes intended to be carried – approval</u>	<u>In force 1/7/2014 by MSC.339(91)</u>
<b>Noise Code</b>		
<u>Para 3.3.9</u>	<u>Operating conditions at sea trials for ships with dynamic positioning (DP)</u>	<u>Mandatory under SOLAS II-1/3-12 (in force 1/7/2014 by MSC.338(91))</u> <u>In force 1/7/2014 by MSC.337(91)</u>

<b>SPECIFIC PORT STATE OBLIGATIONS</b>		
<b>SOURCE</b>	<b>SUMMARY DESCRIPTION</b>	<b>COMMENTS</b>
<b>MARPOL</b> <u>Annex III, req. 8</u>	<u>Port State control on operational requirements</u>	<u>In force 1/1/2014 by MEPC.193(61)</u>

\*\*\*





**ANNEX 30**

**DRAFT ASSEMBLY RESOLUTION**

**IMO SHIP IDENTIFICATION NUMBER SCHEME**

THE ASSEMBLY,

RECALLING Article 15(j) of the Convention on the International Maritime Organization concerning the functions of the Assembly in relation to regulations and guidelines concerning maritime safety and the prevention and control of marine pollution from ships,

BELIEVING that the enhancement of maritime safety and pollution prevention and the prevention of maritime fraud could be facilitated if a permanent identification number were assigned to a ship which would remain unchanged upon transfer of its flag and would be inserted on ships' certificates,

RECALLING ALSO that, by resolution A.600(15), it adopted the *IMO Ship Identification Number Scheme*,

RECOGNIZING the need for the IMO Ship Identification Number Scheme to be revised to allow its voluntary application to ships of 100 gross tonnage and above, including fishing vessels,

HAVING CONSIDERED the recommendation made by the Maritime Safety Committee, at its ninety-second session,

1. ADOPTS the IMO Ship Identification Number Scheme, for implementation on a voluntary basis, as set out in the annex to the present resolution;
2. INVITES Governments concerned to implement the scheme as far as it is practicable, and to inform IMO of measures taken in this respect;
3. REQUESTS the Maritime Safety Committee to keep the scheme under review for further improvement as may be necessary;
4. REVOKES resolution A.600(15).

\* \* \*

## ANNEX

### IMO SHIP IDENTIFICATION NUMBER SCHEME

#### Introduction

1 The purpose of the scheme is to enhance maritime safety and pollution prevention and to facilitate the prevention of maritime fraud. It is not intended to prejudice matters of liability, civil law or other commercial considerations in the operation of a ship. The scheme may be applied by Administrations on a voluntary basis for new and existing ships, under their flag, engaged in international voyages. Administrations may also wish to assign the IMO numbers to ships engaged solely on domestic voyages and to insert the number in the national certificates.

#### Application

2 The scheme applies to seagoing ships of 100 gross tonnage and above, with the exception of the following:

- ships without mechanical means of propulsion;
- pleasure yachts;
- ships engaged on special service<sup>1</sup>;
- hopper barges;
- hydrofoils, hovercraft;
- floating docks and structures classified in a similar manner;
- ships of war and troop ships; and
- wooden ships in general.

#### Assignment of IMO number

3 The IMO number is a number, allocated by IHS-Fairplay (IHS-F) at the time of build or when a ship is first included in the register, with the prefix IMO (e.g. 8712345). Administrations which have decided to implement the scheme are invited to assign all appropriate ships flying their flags, or cause them to be assigned, the IMO numbers and to insert them on ships' certificates.

4 For new ships, the assignment to the IMO number should be made when the ship is registered. For existing ships, the assignment of the IMO number should be made at an early convenient date, such as when the renewal survey is completed or new certificates are issued.

5 Administrations implementing the scheme are invited to inform the Organization accordingly, for circulation to other Governments.

---

<sup>1</sup> For example, lightships, floating radio stations, search and rescue vessels.

6 Official publications and other information from IHS-Fairplay (IHS-F) are sources for referencing the identification number. If the particulars of a ship do not correspond to those shown in the Register of Ships and its supplement because, for example, the ship had changed its name, or the port State control officer had doubts as to whether the numbers given on the certificates were genuine, further clarification may be sought from IHS-Fairplay (IHS-F), the IMO Secretariat or the flag State.

### **Certificates on which the IMO number is to be inserted**

7 The IMO number should be inserted on a ship's Certificate of Registry which includes the particulars identifying the ship, and on all certificates issued under IMO Conventions when and where appropriate. It is recommended that the IMO number also be inserted in other certificates, such as classification certificates, when and where appropriate. The IMO number should preferably be included in the box headed "Distinctive number or letters" in addition to the call sign.

### **How to obtain the IMO number**

8 For obtaining IMO number for both new and existing ships and making ad hoc enquiries, please contact the following website [www.imonumbers.lrfairplay.com](http://www.imonumbers.lrfairplay.com) or requests can be sent to the IHS-F Service at the following address:

IHS Fairplay  
Lombard House  
3 Princess Way  
Redhill  
Surrey  
RH1 1UP  
United Kingdom  
Tel: +441737379054  
Fax: +441737379040  
E-mail: [ship.imo@ihs.com](mailto:ship.imo@ihs.com)

### **New ships (on order and under construction)**

9 The IMO number can be obtained by one of the following methods:

- .1 inquiries should be addressed to IHS-Fairplay by telephone, e-mail or facsimile. In making such inquiry particulars of the ships, should be presented<sup>2</sup>.

Based on the above information, IHS-Fairplay will provide the necessary IMO number free of charge. If there are no data in the IHS-Fairplay new construction file on the ship concerning which the inquiry is made, a new record on that ship will be created and the IHS-Fairplay number will be assigned.

- .2 online access to the new construction file through Sea-web (IMO has access to this system).

---

<sup>2</sup> List of particulars can be found in the form annexed to circular letters on the *IMO Ship Identification Number Scheme* (e.g. Circular letter No.1886/Rev.4).

- .3 application through IHS-Fairplay which will provide a service of regular listings of the order book with selected data items, produced for a client's specification.

### **Existing ships**

10 For existing ships, IHS Fairplay is prepared to answer ad hoc requests free of charge up to a reasonable point of acceptability.

### **Inquiry to the IMO Secretariat**

11 The IMO number may also be obtained free of charge from the IMO Secretariat (Maritime Safety Division – facsimile: +44(0)20 7587 3210) which has access to the Sea-web system. In making such an inquiry to the IMO Secretariat, information on particulars of the ship (as in paragraph 9.1) should be provided. The quickest route for issuance of a number is to contact IHS Fairplay direct at the address in paragraph 8.

---