



MARITIME SAFETY COMMITTEE
85th session
Agenda item 26

MSC 85/26/Add.1
6 January 2009
Original: ENGLISH

**REPORT OF THE MARITIME SAFETY COMMITTEE ON ITS
EIGHTY-FIFTH SESSION**

Attached are annexes 1, 2 and 4 to 28 to the report of the Maritime Safety Committee on its eighty-fifth session (MSC 85/26).

For reasons of economy, this document is printed in a limited number. Delegates are kindly asked to bring their copies to meetings and not to request additional copies.

LIST OF ANNEXES

- ANNEX 1 DRAFT AMENDMENTS TO SOLAS REGULATIONS VI/1 AND VI/5-1
- ANNEX 2 RESOLUTION MSC.267(85) – ADOPTION OF THE INTERNATIONAL CODE ON INTACT STABILITY, 2008 (2008 IS CODE)
- ANNEX 4 RESOLUTION MSC.269(85) – ADOPTION OF AMENDMENTS TO THE INTERNATIONAL CONVENTION FOR THE SAFETY OF LIFE AT SEA, 1974, AS AMENDED
- ANNEX 5 RESOLUTION MSC.270(85) – ADOPTION OF AMENDMENTS TO THE PROTOCOL OF 1988 RELATING TO THE INTERNATIONAL CONVENTION ON LOAD LINES, 1966, AS AMENDED
- ANNEX 6 RESOLUTION MSC.271(85) – ADOPTION OF AMENDMENTS TO THE INTERNATIONAL CODE OF SAFETY FOR HIGH-SPEED CRAFT, 2000 (2000 HSC CODE)
- ANNEX 7 RESOLUTION MSC.272(85) – ADOPTION OF AMENDMENTS TO THE INTERNATIONAL LIFE-SAVING APPLIANCE (LSA) CODE
- ANNEX 8 RESOLUTION MSC.273(85) – ADOPTION OF AMENDMENTS TO THE INTERNATIONAL MANAGEMENT CODE FOR THE SAFE OPERATION OF SHIPS AND FOR POLLUTION PREVENTION (INTERNATIONAL SAFETY MANAGEMENT (ISM) CODE)
- ANNEX 9 RESOLUTION MSC.274(85) – ADOPTION OF AMENDMENTS TO THE REVISED RECOMMENDATION ON TESTING OF LIFE-SAVING APPLIANCES (RESOLUTION MSC.81(70))
- ANNEX 10 RESOLUTION MSC.275(85) – APPOINTMENT OF THE LRIT COORDINATOR
- ANNEX 11 RESOLUTION MSC.276(85) – OPERATION OF THE INTERNATIONAL LRIT DATA EXCHANGE ON AN INTERIM BASIS
- ANNEX 12 DRAFT AMENDMENTS TO SOLAS REGULATION II-1/3-5.2
- ANNEX 13 RESOLUTION MSC.277(85) – CLARIFICATION OF THE TERM “BULK CARRIER” AND GUIDANCE FOR APPLICATION OF REGULATIONS IN SOLAS TO SHIPS WHICH OCCASIONALLY CARRY DRY CARGOES IN BULK AND ARE NOT DETERMINED AS BULK CARRIERS IN ACCORDANCE WITH REGULATION XII/1.1 AND CHAPTER II-1
- ANNEX 14 NEW AND AMENDED TRAFFIC SEPARATION SCHEMES AND ASSOCIATED ROUTEING MEASURES

- ANNEX 15 ROUTEING MEASURES OTHER THAN TRAFFIC SEPARATION SCHEMES
- ANNEX 16 RESOLUTION MSC.278(85) – ADOPTION OF THE NEW MANDATORY SHIP REPORTING SYSTEM “OFF THE COAST OF PORTUGAL – COPREP”
- ANNEX 17 RESOLUTION MSC.279(85) – ADOPTION OF AMENDMENTS TO THE EXISTING SHIP REPORTING SYSTEM FOR THE “PAPAHĀNAUMOKUĀKEA MARINE NATIONAL MONUMENT”, PARTICULARLY SENSITIVE SEA AREA, “CORAL SHIPREP”
- ANNEX 18 RESOLUTION MSC.280(85) – ADOPTION OF AMENDMENTS TO THE GENERAL PROVISIONS ON SHIPS’ ROUTEING (RESOLUTION A.572(14), AS AMENDED)
- ANNEX 19 DRAFT AMENDMENTS TO SOLAS REGULATION V/19
- ANNEX 20 STRATEGY FOR THE DEVELOPMENT AND IMPLEMENTATION OF E-NAVIGATION
- ANNEX 21 FRAMEWORK FOR THE IMPLEMENTATION PROCESS FOR THE E-NAVIGATION STRATEGY
- ANNEX 22 RESOLUTION MSC.281(85) – EXPLANATORY NOTES TO THE SOLAS CHAPTER II-1 SUBDIVISION AND DAMAGE STABILITY REGULATIONS
- ANNEX 23 THEMATIC PRIORITIES FOR INCLUSION IN THE ITCP COVERING THE 2010-2011 BIENNIUM
- ANNEX 24 WORK PROGRAMMES OF THE SUB-COMMITTEES
- ANNEX 25 PROVISIONAL AGENDAS FOR THE FORTHCOMING SESSIONS OF THE SUB-COMMITTEES
- ANNEX 26 STATEMENT BY THE DELEGATION OF HONG KONG, CHINA
- ANNEX 27 STATEMENTS BY THE DELEGATION OF TURKEY
- ANNEX 28 STATEMENT BY THE DELEGATION OF GREECE

(See document MSC 85/26/Add.2 for annex 3)

ANNEX 1

DRAFT AMENDMENTS TO SOLAS REGULATIONS VI/1 AND VI/5-1

**CHAPTER VI
CARRIAGE OF CARGOES**

- 1 The title of chapter VI is replaced by the following:

“CARRIAGE OF CARGOES AND OIL FUELS”

Regulation 1 – Application

- 2 At the beginning of paragraph 1, the words “Unless expressly provided otherwise,” are added and the existing word “This” is replaced by the word “this”.

Regulation 5-1 – Material safety data sheets

- 3 The existing text of the regulation is replaced by the following:

“Ships carrying oil or oil fuel, as defined in regulation 1 of Annex 1 of the International Convention for the Prevention of Pollution from Ships, 1973, as modified by the Protocol of 1978 relating thereto, shall be provided with material safety data sheets, based on the recommendations developed by the Organization*, prior to the loading of such oil as cargo in bulk or bunkering of oil fuel.”

* Refer to the Recommendation for material safety data sheets (MSDS) for MARPOL Annex I cargoes and marine fuel oils, adopted by the Organization by resolution MSC.150(77), as may be amended.

ANNEX 2

**RESOLUTION MSC.267(85)
(adopted on 4 December 2008)****ADOPTION OF THE INTERNATIONAL CODE ON INTACT STABILITY, 2008
(2008 IS CODE)**

THE MARITIME SAFETY COMMITTEE,

RECALLING Article 28(b) of the Convention on the International Maritime Organization concerning the functions of the Committee,

RECALLING ALSO resolution A.749(18) entitled “Code on Intact Stability for All Types of Ships Covered by IMO Instruments”, as amended by resolution MSC.75(69),

RECOGNIZING the need to update the aforementioned Code and the importance of establishing mandatory international intact stability requirements,

NOTING resolutions MSC.269(85) and MSC.270(85), by which it adopted, *inter alia*, amendments to the International Convention for the Safety of Life at Sea (SOLAS), 1974, as amended (hereinafter referred to as “the 1974 SOLAS Convention”) and to the Protocol of 1988 relating to the International Convention on Load Lines, 1966 (hereinafter referred to as “the 1988 Load Lines Protocol”), respectively, to make the introduction and the provisions of part A of the International Code on Intact Stability, 2008 mandatory under the 1974 SOLAS Convention and the 1988 Load Lines Protocol,

HAVING CONSIDERED, at its eighty-fifth session, the text of the proposed International Code on Intact Stability, 2008,

1. ADOPTS the International Code on Intact Stability, 2008 (2008 IS Code), the text of which is set out in the Annex to the present resolution;
2. INVITES Contracting Governments to the 1974 SOLAS Convention and Parties to the 1988 Load Lines Protocol to note that the 2008 IS Code will take effect on 1 July 2010 upon the entry into force of the respective amendments to the 1974 SOLAS Convention and 1988 Load Lines Protocol;
3. REQUESTS the Secretary-General to transmit certified copies of the present resolution and the text of the 2008 IS Code contained in the Annex to all Contracting Governments to the 1974 SOLAS Convention and Parties to the 1988 Load Lines Protocol;
4. FURTHER REQUESTS the Secretary-General to transmit copies of this resolution and the Annex to all Members of the Organization which are not Contracting Governments to the 1974 SOLAS Convention or Parties to the 1988 Load Lines Protocol;
5. RECOMMENDS Governments concerned to use the recommendatory provisions contained in part B of the 2008 IS Code as a basis for relevant safety standards, unless their national stability requirements provide at least an equivalent degree of safety.

ANNEX

**INTERNATIONAL CODE ON INTACT STABILITY, 2008
(2008 IS CODE)**

CONTENTS

PREAMBLE

INTRODUCTION

- 1 Purpose
- 2 Definitions

PART A – MANDATORY CRITERIA

Chapter 1 – General

- 1.1 Application
- 1.2 Dynamic stability phenomena in waves

Chapter 2 – General criteria

- 2.1 General
- 2.2 Criteria regarding righting lever curve properties
- 2.3 Severe wind and rolling criterion (weather criterion)

Chapter 3 – Special criteria for certain types of ships

- 3.1 Passenger ships
- 3.2 Oil tankers of 5,000 dwt and above
- 3.3 Cargo ships carrying timber deck cargoes
- 3.4 Cargo ships carrying grain in bulk
- 3.5 High-speed craft

**PART B – RECOMMENDATIONS FOR CERTAIN TYPES OF SHIPS AND
ADDITIONAL GUIDELINES**

Chapter 1 – General

- 1.1 Purpose
- 1.2 Application

Chapter 2 – Recommended design criteria for certain types of ships

- 2.1 Fishing vessels
- 2.2 Pontoons
- 2.3 Containerships greater than 100 m
- 2.4 Offshore supply vessels
- 2.5 Special purpose ships
- 2.6 Mobile offshore drilling units (MODUs)

- Chapter 3 – Guidance in preparing stability information**
- 3.1 Effect of free surfaces of liquids in tanks
 - 3.2 Permanent ballast
 - 3.3 Assessment of compliance with stability criteria
 - 3.4 Standard conditions of loading to be examined
 - 3.5 Calculation of stability curves
 - 3.6 Stability booklet
 - 3.7 Operational measures for ships carrying timber deck cargoes
 - 3.8 Operating booklets for certain ships
- Chapter 4 – Stability calculations performed by stability instruments**
- 4.1 Stability instruments
- Chapter 5 – Operational provisions against capsizing**
- 5.1 General precautions against capsizing
 - 5.2 Operational precautions in heavy weather
 - 5.3 Ship handling in heavy weather
- Chapter 6 – Icing considerations**
- 6.1 General
 - 6.2 Cargo ships carrying timber deck cargoes
 - 6.3 Fishing vessels
 - 6.4 Offshore supply vessels 24 m to 100 m in length
- Chapter 7 – Considerations for watertight and weathertight integrity**
- 7.1 Hatchways
 - 7.2 Machinery space openings
 - 7.3 Doors
 - 7.4 Cargo ports and other similar openings
 - 7.5 Sidescuttles, window scuppers, inlets and discharges
 - 7.6 Other deck openings
 - 7.7 Ventilators, air pipes and sounding devices
 - 7.8 Freeing ports
 - 7.9 Miscellaneous
- Chapter 8 – Determination of lightship parameters**
- 8.1 Application
 - 8.2 Preparations for the inclining test
 - 8.3 Plans required
 - 8.4 Test procedure
 - 8.5 Inclining test for MODUs
 - 8.6 Stability test for pontoons

Annex 1 – Detailed guidance for the conduct of an inclining test

- 1 Introduction
- 2 Preparations for the inclining test
 - 2.1 Free surface and tankage
 - 2.2 Mooring arrangements
 - 2.3 Test weights
 - 2.4 Pendulums
 - 2.5 U-tubes
 - 2.6 Inclinometers
- 3 Equipment required
- 4 Test procedure
 - 4.1 Initial walk through and survey
 - 4.2 Freeboard/draught readings
 - 4.3 The incline

Annex 2 – Recommendations for skippers of fishing vessels on ensuring a vessel's endurance in conditions of ice formation

- 1 Prior to departure
- 2 At sea
- 3 During ice formation
- 4 List of equipment and hand tools

PREAMBLE

1 This Code has been assembled to provide, in a single document, mandatory requirements in the introduction and in part A and recommended provisions in part B relating to intact stability, based primarily on existing IMO instruments. Where recommendations in this Code appear to differ from other IMO Codes, the other Codes should be taken as the prevailing instrument. For the sake of completeness and for the convenience of the user, this Code also contains relevant provisions from mandatory IMO instruments.

2 Criteria included in the Code are based on the best “state-of-the-art” concepts, available at the time they were developed, taking into account sound design and engineering principles and experience gained from operating ships. Furthermore, design technology for modern ships is rapidly evolving and the Code should not remain static but should be re-evaluated and revised, as necessary. To this end, the Organization will periodically review the Code taking into consideration both experience and further development.

3 A number of influences such as the dead ship condition, wind on ships with large windage area, rolling characteristics, severe seas, etc., were taken into account based on the state-of-the-art technology and knowledge at the time of the development of the Code.

4 It was recognized that in view of a wide variety of types, sizes of ships and their operating and environmental conditions, problems of safety against accidents related to stability have generally not yet been solved. In particular, the safety of a ship in a seaway involves complex hydrodynamic phenomena which up to now have not been fully investigated and understood. Motion of ships in a seaway should be treated as a dynamical system and relationships between ship and environmental conditions like wave and wind excitations are recognized as extremely important elements. Based on hydrodynamic aspects and stability analysis of a ship in a seaway, stability criteria development poses complex problems that require further research.

INTRODUCTION

1 Purpose

1.1 The purpose of the Code is to present mandatory and recommendatory stability criteria and other measures for ensuring the safe operation of ships, to minimize the risk to such ships, to the personnel on board and to the environment. This introduction and part A of the Code address the mandatory criteria and part B contains recommendations and additional guidelines.

1.2 This Code contains intact stability criteria for the following types of ships and other marine vehicles of 24 m in length and above, unless otherwise stated:

- .1 cargo ships;
- .2 cargo ships carrying timber deck cargoes;
- .3 passenger ships;
- .4 fishing vessels;
- .5 special purpose ships;
- .6 offshore supply vessels;
- .7 mobile offshore drilling units;
- .8 pontoons; and
- .9 cargo ships carrying containers on deck and containerships.

1.3 Administrations may impose additional requirements regarding the design aspects of ships of novel design or ships not otherwise covered by the Code.

2 Definitions

For the purpose of this Code the definitions given hereunder shall apply. For terms used, but not defined in this Code, the definitions as given in the 1974 SOLAS Convention, as amended, shall apply.

2.1 *Administration* means the Government of the State whose flag the ship is entitled to fly.

2.2 *Passenger ship* is a ship which carries more than twelve passengers as defined in regulation I/2 of the 1974 SOLAS Convention, as amended.

2.3 *Cargo ship* is any ship which is not a passenger ship, a ship of war and troopship, a ship which is not propelled by mechanical means, a wooden ship of primitive build, a fishing vessel or a mobile offshore drilling unit.

2.4 *Oil tanker* means a ship constructed or adapted primarily to carry oil in bulk in its cargo spaces and includes combination carriers and any chemical tanker as defined in Annex II of the MARPOL Convention when it is carrying a cargo or part cargo of oil in bulk.

- 2.4.1 *Combination carrier* means a ship designed to carry either oil or solid cargoes in bulk.
- 2.4.2 *Crude oil tanker* means an oil tanker engaged in the trade of carrying crude oil.
- 2.4.3 *Product carrier* means an oil tanker engaged in the trade of carrying oil other than crude oil.
- 2.5 *Fishing vessel* is a vessel used for catching fish, whales, seals, walrus or other living resources of the sea.
- 2.6 *Special purpose ship* has the same definition as in the Code of Safety for Special Purpose Ships, 2008 (resolution MSC.266(84)).
- 2.7 *Offshore supply vessel* means a vessel which is engaged primarily in the transport of stores, materials and equipment to offshore installations and designed with accommodation and bridge erections in the forward part of the vessel and an exposed cargo deck in the after part for the handling of cargo at sea.
- 2.8 *Mobile offshore drilling unit (MODU or unit)* is a ship capable of engaging in drilling operations for the exploration or exploitation of resources beneath the sea-bed such as liquid or gaseous hydrocarbons, sulphur or salt.
- 2.8.1 *Column-stabilized unit* is a unit with the main deck connected to the underwater hull or footings by columns or caissons.
- 2.8.2 *Surface unit* is a unit with a ship- or barge-type displacement hull of single or multiple hull construction intended for operation in the floating condition.
- 2.8.3 *Self-elevating unit* is a unit with moveable legs capable of raising its hull above the surface of the sea.
- 2.8.4 *Coastal State* means the Government of the State exercising administrative control over the drilling operations of the unit.
- 2.8.5 *Mode of operation* means a condition or manner in which a unit may operate or function while on location or in transit. The modes of operation of a unit include the following:
- .1 *operating conditions* means conditions wherein a unit is on location for the purpose of conducting drilling operations, and combined environmental and operational loadings are within the appropriate design limits established for such operations. The unit may be either afloat or supported on the sea-bed, as applicable;
 - .2 *severe storm conditions* means conditions wherein a unit may be subjected to the most severe environmental loadings for which the unit is designed. Drilling operations are assumed to have been discontinued due to the severity of the environmental loadings, the unit may be either afloat or supported on the sea-bed, as applicable; and
 - .3 *transit conditions* means conditions wherein a unit is moving from one geographical location to another.

2.9 *High-speed craft* (HSC)¹ is a craft capable of a maximum speed, in metres per second (m/s), equal to or exceeding:

$$3.7 * \nabla^{0.1667}$$

where: ∇ = displacement corresponding to the design waterline (m³).

2.10 *Containership* means a ship which is used primarily for the transport of marine containers.

2.11 *Freeboard* is the distance between the assigned load line and freeboard deck².

2.12 *Length of ship*. The length should be taken as 96% of the total length on a waterline at 85% of the least moulded depth measured from the top of the keel, or as the length from the fore side of the stem to the axis of the rudder stock on the waterline, if that be greater. In ships designed with a rake of keel the waterline on which this length is measured should be parallel to the designed waterline.

2.13 *Moulded breadth* is the maximum breadth of the ship measured amidships to the moulded line of the frame in a ship with a metal shell and to the outer surface of the hull in a ship with a shell of any other material.

2.14 *Moulded depth* is the vertical distance measured from the top of the keel to the top of the freeboard deck beam at side. In wood and composite ships, the distance is measured from the lower edge of the keel rabbet. Where the form at the lower part of the midship section is of a hollow character, or where thick garboards are fitted, the distance is measured from the point where the line of the flat of the bottom continued inwards cuts the side of the keel. In ships having rounded gunwales, the moulded depth should be measured to the point of intersection of the moulded lines of the deck and side shell plating, the lines extending as though the gunwale were of angular design. Where the freeboard deck is stepped and the raised part of the deck extends over the point at which the moulded depth is to be determined, the moulded depth should be measured to a line of reference extending from the lower part of the deck along a line parallel with the raised part.

2.15 *Near-coastal voyage* means a voyage in the vicinity of the coast of a State as defined by the Administration of that State.

¹ The Code of Safety for High-Speed Craft, 2000 (2000 HSC Code) has been developed following a thorough revision of the Code of Safety for High-Speed Craft, 1994 (1994 HSC Code) which was derived from the previous Code of Safety for Dynamically Supported Craft (DSC Code) adopted by IMO in 1977, recognizing that safety levels can be significantly enhanced by the infrastructure associated with regular service on a particular route, whereas the conventional ship safety philosophy relies on the ship being self-sustaining with all necessary emergency equipment being carried on board.

² For the purposes of application of chapters I and II of Annex I of the International Convention on Load Lines, 1966 or the Protocol of 1988 as amended, as applicable to open-top containerships, "freeboard deck" is the freeboard deck according to the International Convention on Load Lines, 1966 or the Protocol of 1988 as amended, as applicable as if hatch covers are fitted on top of the hatch cargo coamings.

2.16 *Pontoon* is considered to be normally:

- .1 non self-propelled;
- .2 unmanned;
- .3 carrying only deck cargo;
- .4 having a block coefficient of 0.9 or greater;
- .5 having a breadth/depth ratio of greater than 3; and
- .6 having no hatchways in the deck except small manholes closed with gasketed covers.

2.17 *Timber* means sawn wood or lumber, cants, logs, poles, pulpwood and all other types of timber in loose or packaged forms. The term does not include wood pulp or similar cargo.

2.18 *Timber deck cargo* means a cargo of timber carried on an uncovered part of a freeboard or superstructure deck. The term does not include wood pulp or similar cargo.³

2.19 *Timber load line* means a special load line assigned to ships complying with certain conditions related to their construction set out in the International Convention on Load Lines and used when the cargo complies with the stowage and securing conditions of the Code of Safe Practice for Ships Carrying Timber Deck Cargoes, 1991 (resolution A.715(17)).

2.20 *Certification of the inclining test weights* is the verification of the weight marked on a test weight. Test weights should be certified using a certificated scale. The weighing should be performed close enough in time to the inclining test to ensure the measured weight is accurate.

2.21 *Draught* is the vertical distance from the moulded baseline to the waterline.

2.22 The *inclining test* involves moving a series of known weights, normally in the transverse direction, and then measuring the resulting change in the equilibrium heel angle of the ship. By using this information and applying basic naval architecture principles, the ship's vertical centre of gravity (VCG) is determined.

2.23 *Lightship condition* is a ship complete in all respects, but without consumables, stores, cargo, crew and effects, and without any liquids on board except that machinery and piping fluids, such as lubricants and hydraulics, are at operating levels.

2.24 A *lightweight survey* involves taking an audit of all items which should be added, deducted or relocated on the ship at the time of the inclining test so that the observed condition of the ship can be adjusted to the lightship condition. The mass, longitudinal, transverse and vertical location of each item should be accurately determined and recorded. Using this information, the static waterline of the ship at the time of the inclining test as determined from measuring the freeboard or verified draught marks of the ship, the ship's hydrostatic data, and the

³ Refer to regulation 42(1) of the International Convention on Load Lines, 1966 or the Protocol of 1988 as amended, as applicable.

sea water density, the lightship displacement and longitudinal centre of gravity (LCG) can be obtained. The transverse centre of gravity (TCG) may also be determined for mobile offshore drilling units (MODUs) and other ships which are asymmetrical about the centreline or whose internal arrangement or outfitting is such that an inherent list may develop from off-centre mass.

2.25 An *in-service inclining test* means an inclining test which is performed in order to verify the pre-calculated GM_C and the deadweight's centre of gravity of an actual loading condition.

2.26 A *stability instrument* is an instrument installed on board a particular ship by means of which it can be ascertained that stability requirements specified for the ship in the Stability Booklet are met in any operational loading condition. A Stability Instrument comprises hardware and software.

PART A
MANDATORY CRITERIA

CHAPTER 1 – GENERAL

1.1 Application

1.1.1 The criteria stated under chapter 2 of this part present a set of minimum requirements that shall apply to cargo⁴ and passenger ships of 24 m in length and over.

1.1.2 The criteria stated under chapter 3 are special criteria for certain types of ships. For the purpose of part A the definitions given in the Introduction apply.

1.2 Dynamic stability phenomena in waves

Administrations shall be aware that some ships are more at risk of encountering critical stability situations in waves. Necessary precautionary provisions may need to be taken in the design to address the severity of such phenomena. The phenomena in seaways which may cause large roll angles and/or accelerations have been identified hereunder.

Having regard to the phenomena described in this section, the Administration may for a particular ship or group of ships apply criteria demonstrating that the safety of the ship is sufficient. Any Administration which applies such criteria should communicate to the Organization particulars thereof. It is recognized by the Organization that performance oriented criteria for the identified phenomena listed in this section need to be developed and implemented to ensure a uniform international level of safety.

1.2.1 Righting lever variation

Any ship exhibiting large righting lever variations between wave trough and wave crest condition may experience parametric roll or pure loss of stability or combinations thereof.

1.2.2 Resonant roll in dead ship condition

Ships without propulsion or steering ability may be endangered by resonant roll while drifting freely.

1.2.3 Broaching and other manoeuvring related phenomena

Ships in following and quartering seas may not be able to keep constant course despite maximum steering efforts which may lead to extreme angles of heel.

⁴ For container ships of 100 m in length and over, provisions of chapter 2.3 of part B may be applied as an alternative to the application of chapter 2.2 of this part. Offshore supply vessels and special purpose ships are not required to comply with provisions of chapter 2.3 of part A. For offshore supply vessels, provisions of chapter 2.4 of part B may be applied as an alternative to the application of chapter 2.2 of this part. For special purpose ships, provisions of chapter 2.5 of part B may be applied as an alternative to the application of chapter 2.2 of this part.

CHAPTER 2 – GENERAL CRITERIA

2.1 General

2.1.1 All criteria shall be applied for all conditions of loading as set out in part B, 3.3 and 3.4.

2.1.2 Free surface effects (part B, 3.1) shall be accounted for in all conditions of loading as set out in part B, 3.3 and 3.4.

2.1.3 Where anti-rolling devices are installed in a ship, the Administration shall be satisfied that the criteria can be maintained when the devices are in operation and that failure of power supply or the failure of the device(s) will not result in the vessel being unable to meet the relevant provisions of this Code.

2.1.4 A number of influences such as icing of topsides, water trapped on deck, etc., adversely affect stability and the Administration is advised to take these into account, so far as is deemed necessary.

2.1.5 Provisions shall be made for a safe margin of stability at all stages of the voyage, regard being given to additions of weight, such as those due to absorption of water and icing (details regarding ice accretion are given in part B, chapter 6 – Icing considerations) and to losses of weight such as those due to consumption of fuel and stores.

2.1.6 Each ship shall be provided with a stability booklet, approved by the Administration, which contains sufficient information (see part B, 3.6) to enable the master to operate the ship in compliance with the applicable requirements contained in the Code. If a stability instrument is used as a supplement to the stability booklet for the purpose of determining compliance with the relevant stability criteria such instrument shall be subject to the approval by the Administration (see part B, chapter 4 – Stability calculations performed by stability instruments).

2.1.7 If curves or tables of minimum operational metacentric height (GM) or maximum centre of gravity (VCG) are used to ensure compliance with the relevant intact stability criteria those limiting curves shall extend over the full range of operational trims, unless the Administration agrees that trim effects are not significant. When curves or tables of minimum operational metacentric height (GM) or maximum centre of gravity (VCG) versus draught covering the operational trims are not available, the master must verify that the operating condition does not deviate from a studied loading condition, or verify by calculation that the stability criteria are satisfied for this loading condition taking into account trim effects.

2.2 Criteria regarding righting lever curve properties

2.2.1 The area under the righting lever curve (GZ curve) shall not be less than 0.055 metre-radians up to $\varphi = 30^\circ$ angle of heel and not less than 0.09 metre-radians up to $\varphi = 40^\circ$ or the angle of down-flooding φ_f^5 if this angle is less than 40° . Additionally, the area under the righting lever curve (GZ curve) between the angles of heel of 30° and 40° or between 30° and φ_f , if this angle is less than 40° , shall not be less than 0.03 metre-radians.

⁵ φ_f is an angle of heel at which openings in the hull, superstructures or deckhouses which cannot be closed weathertight immerse. In applying this criterion, small openings through which progressive flooding cannot take place need not be considered as open.

2.2.2 The righting lever GZ shall be at least 0.2 m at an angle of heel equal to or greater than 30°.

2.2.3 The maximum righting lever shall occur at an angle of heel not less than 25°. If this is not practicable, alternative criteria, based on an equivalent level of safety⁶, may be applied subject to the approval of the Administration.

2.2.4 The initial metacentric height GM_0 shall not be less than 0.15 m.

2.3 Severe wind and rolling criterion (weather criterion)

2.3.1 The ability of a ship to withstand the combined effects of beam wind and rolling shall be demonstrated, with reference to figure 2.3.1 as follows:

- .1 the ship is subjected to a steady wind pressure acting perpendicular to the ship's centreline which results in a steady wind heeling lever (l_{w1});
- .2 from the resultant angle of equilibrium (φ_0), the ship is assumed to roll owing to wave action to an angle of roll (φ_1) to windward. The angle of heel under action of steady wind (φ_0) should not exceed 16° or 80% of the angle of deck edge immersion, whichever is less;
- .3 the ship is then subjected to a gust wind pressure which results in a gust wind heeling lever (l_{w2}); and
- .4 under these circumstances, area b shall be equal to or greater than area a , as indicated in figure 2.3.1 below:

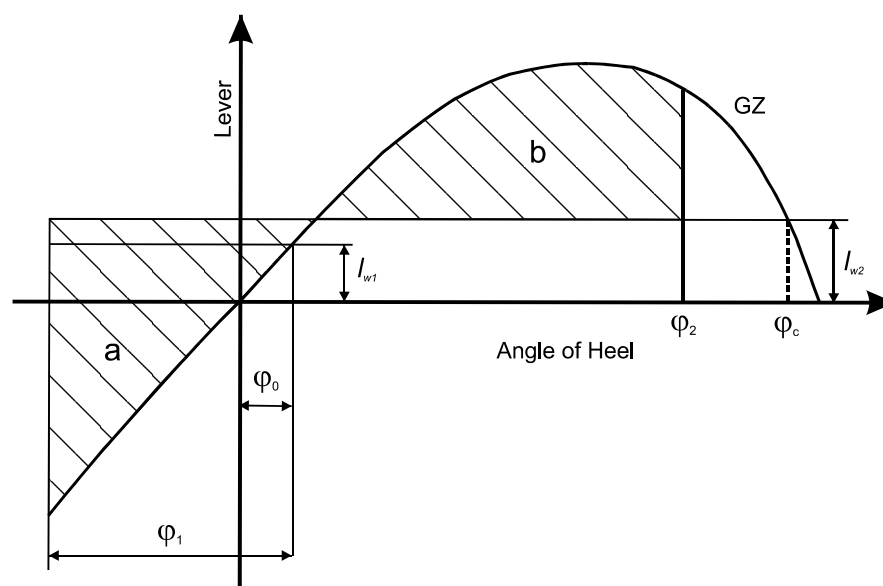

Figure 2.3.1 – Severe wind and rolling

⁶ Refer to the Explanatory Notes to the International Code on Intact Stability, 2008 (MSC.1/Circ.1281).

where the angles in figure 2.3.1 are defined as follows:

φ_0 = angle of heel under action of steady wind

φ_1 = angle of roll to windward due to wave action (see 2.3.1.2, 2.3.4 and footnote 6)

φ_2 = angle of down-flooding (φ_f) or 50° or φ_c , whichever is less,

where:

φ_f = angle of heel at which openings in the hull, superstructures or deckhouses which cannot be closed weathertight immerse. In applying this criterion, small openings through which progressive flooding cannot take place need not be considered as open

φ_c = angle of second intercept between wind heeling lever l_{w2} and GZ curves.

2.3.2 The wind heeling levers l_{w1} and l_{w2} referred to in 2.3.1.1 and 2.3.1.3 are constant values at all angles of inclination and shall be calculated as follows:

$$l_{w1} = \frac{P * A * Z}{1000 * g * \Delta} \quad (m) \quad \text{and}$$

$$l_{w2} = 1.5 * l_{w1} \quad (m)$$

where:

P = wind pressure of 504 Pa. The value of P used for ships in restricted service may be reduced subject to the approval of the Administration

A = projected lateral area of the portion of the ship and deck cargo above the waterline (m^2)

Z = vertical distance from the centre of A to the centre of the underwater lateral area or approximately to a point at one half the mean draught (m)

Δ = displacement (t)

g = gravitational acceleration of 9.81 m/s^2 .

2.3.3 Alternative means for determining the wind heeling lever (l_{w1}) may be accepted, to the satisfaction of the Administration, as an equivalent to calculation in 2.3.2. When such alternative tests are carried out, reference shall be made based on the Guidelines developed by the Organization⁷. The wind velocity used in the tests shall be 26 m/s in full scale with uniform velocity profile. The value of wind velocity used for ships in restricted services may be reduced to the satisfaction of the Administration.

⁷ Refer to the Interim Guidelines for alternative assessment of the weather criterion (MSC.1/Circ.1200).

2.3.4 The angle of roll (φ_1)⁸ referred to in 2.3.1.2 shall be calculated as follows:

$$\varphi_1 = 109 * k * X_1 * X_2 * \sqrt{r * s} \quad (\text{degrees})$$

where:

X_1 = factor as shown in table 2.3.4-1

X_2 = factor as shown in table 2.3.4-2

k = factor as follows:

k = 1.0 for round-bilged ship having no bilge or bar keels

k = 0.7 for a ship having sharp bilges

k = as shown in table 2.3.4-3 for a ship having bilge keels, a bar keel or both

$$r = 0.73 + 0.6 OG/d$$

with:

$$OG = KG - d$$

d = mean moulded draught of the ship (m)

s = factor as shown in table 2.3.4-4, where T is the ship roll natural period. In absence of sufficient information, the following approximate formula can be used:

$$\text{Rolling period} \quad T = \frac{2 * C * B}{\sqrt{GM}} \quad (s)$$

where:

$$C = 0.373 + 0.023(B/d) - 0.043(L_{wl}/100).$$

The symbols in tables 2.3.4-1, 2.3.4-2, 2.3.4-3 and 2.3.4-4 and the formula for the rolling period are defined as follows:

L_{wl} = length of the ship at waterline (m)

B = moulded breadth of the ship (m)

⁸ The angle of roll for ships with anti-rolling devices should be determined without taking into account the operation of these devices unless the Administration is satisfied with the proof that the devices are effective even with sudden shutdown of their supplied power.

d = mean moulded draught of the ship (m)

C_B = block coefficient (-)

A_k = total overall area of bilge keels, or area of the lateral projection of the bar keel, or sum of these areas (m²)

GM = metacentric height corrected for free surface effect (m).

Table 2.3.4-1 – Values of factor X_1

B/d	X_1
≤ 2.4	1.0
2.5	0.98
2.6	0.96
2.7	0.95
2.8	0.93
2.9	0.91
3.0	0.90
3.1	0.88
3.2	0.86
3.4	0.82
≥ 3.5	0.80

Table 2.3.4-2 – Values of factor X_2

C_B	X_2
≤ 0.45	0.75
0.50	0.82
0.55	0.89
0.60	0.95
0.65	0.97
≥ 0.70	1.00

Table 2.3.4-3 – Values of factor k

$\frac{A_k \times 100}{L_{WL} \times B}$	k
0	1.0
1.0	0.98
1.5	0.95
2.0	0.88
2.5	0.79
3.0	0.74
3.5	0.72
≥ 4.0	0.70

Table 2.3.4-4 – Values of factor s

T	s
≤ 6	0.100
7	0.098
8	0.093
12	0.065
14	0.053
16	0.044
18	0.038
≥ 20	0.035

(Intermediate values in these tables shall be obtained by linear interpolation)

2.3.5 The tables and formulae described in 2.3.4 are based on data from ships having:

- .1 B/d smaller than 3.5;
- .2 $(KG/d-1)$ between - 0.3 and 0.5; and
- .3 T smaller than 20 s.

For ships with parameters outside of the above limits the angle of roll (ϕ_1) may be determined with model experiments of a subject ship with the procedure described in MSC.1/Circ.1200 as the alternative. In addition, the Administration may accept such alternative determinations for any ship, if deemed appropriate.

CHAPTER 3 – SPECIAL CRITERIA FOR CERTAIN TYPES OF SHIPS

3.1 Passenger ships

Passenger ships shall comply with the requirements of 2.2 and 2.3.

3.1.1 In addition, the angle of heel on account of crowding of passengers to one side as defined below shall not exceed 10°.

3.1.1.1 A minimum weight of 75 kg shall be assumed for each passenger except that this value may be increased subject to the approval of the Administration. In addition, the mass and distribution of the luggage shall be approved by the Administration.

3.1.1.2 The height of the centre of gravity for passengers shall be assumed equal to:

- .1 1 m above deck level for passengers standing upright. Account may be taken, if necessary, of camber and sheer of deck; and
- .2 0.3 m above the seat in respect of seated passengers.

3.1.1.3 Passengers and luggage shall be considered to be in the spaces normally at their disposal, when assessing compliance with the criteria given in 2.2.1 to 2.2.4.

3.1.1.4 Passengers without luggage shall be considered as distributed to produce the most unfavourable combination of passenger heeling moment and/or initial metacentric height, which may be obtained in practice, when assessing compliance with the criteria given in 3.1.1 and 3.1.2, respectively. In this connection, a value higher than four persons per square metre is not necessary.

3.1.2 In addition, the angle of heel on account of turning shall not exceed 10° when calculated using the following formula:

$$M_R = 0.200 * \frac{v_o^2}{L_{WL}} * \Delta * \left(KG - \frac{d}{2} \right)$$

where:

M_R = heeling moment (kNm)

v_o = service speed (m/s)

L_{WL} = length of ship at waterline (m)

Δ = displacement (t)

d = mean draught (m)

KG = height of centre of gravity above baseline (m).

3.2 Oil tankers of 5,000 dwt and above

Oil tankers, as defined in section 2 (Definitions) of the Introduction, shall comply with regulation 27 of Annex I to MARPOL 73/78.

3.3 Cargo ships carrying timber deck cargoes

Cargo ships carrying timber deck cargoes shall comply with the requirements of 2.2 and 2.3 unless the Administration is satisfied with the application of alternative provision 3.3.2.

3.3.1 Scope

The provisions given hereunder apply to all ships of 24 m in length and over engaged in the carriage of timber deck cargoes. Ships that are provided with, and make use of, their timber load line shall also comply with the requirements of regulations 41 to 45 of the 1966 Load Line Convention.

3.3.2 Alternative stability criteria

For ships loaded with timber deck cargoes and provided that the cargo extends longitudinally between superstructures (where there is no limiting superstructure at the after end, the timber deck cargo shall extend at least to the after end of the aftermost hatchway)⁹ transversely for the full beam of ship, after due allowance for a rounded gunwale, not exceeding 4% of the breadth of the ship and/or securing the supporting uprights and which remains securely fixed at large angles of heel may be:

3.3.2.1 The area under the righting lever curve (GZ curve) shall not be less than 0.08 metre-radians up to $\varphi = 40^\circ$ or the angle of flooding if this angle is less than 40° .

3.3.2.2 The maximum value of the righting lever (GZ) shall be at least 0.25 m.

3.3.2.3 At all times during a voyage, the metacentric height GM_0 shall not be less than 0.1 m, taking into account the absorption of water by the deck cargo and/or ice accretion on the exposed surfaces (details regarding ice accretion are given in part B, chapter 6 (Icing considerations)).

3.3.2.4 When determining the ability of the ship to withstand the combined effects of beam wind and rolling according to 2.3, the 16° limiting angle of heel under action of steady wind shall be complied with, but the additional criterion of 80% of the angle of deck edge immersion may be ignored.

3.4 Cargo ships carrying grain in bulk

The intact stability of ships engaged in the carriage of grain shall comply with the requirements of the International Code for the Safe Carriage of Grain in Bulk adopted by resolution MSC.23(59).¹⁰

⁹ Refer to regulation 44(2) of the International Convention on Load Lines, 1966 or the Protocol of 1988 relating thereto, as amended, as applicable.

¹⁰ Refer to part C of chapter VI of the 1974 SOLAS Convention as amended by resolution MSC.23(59).

3.5 High-speed craft

High-speed craft, as defined in section 2 (Definitions) of the Introduction, constructed on or after 1 January 1996 but before 1 July 2002, to which chapter X of the 1974 SOLAS Convention applies, shall comply with stability requirements of the 1994 HSC Code (resolution MSC.36(63)). Any high-speed craft to which chapter X of the 1974 SOLAS Convention applies, irrespective of its date of construction, which has undergone repairs, alterations or modifications of a major character; and a high-speed craft constructed on or after 1 July 2002, shall comply with stability requirements of the 2000 HSC Code (resolution MSC.97(73)).

PART B

RECOMMENDATIONS FOR CERTAIN TYPES OF SHIPS AND ADDITIONAL GUIDELINES

CHAPTER 1 – GENERAL

1.1 Purpose

The purpose of this part of the Code is to:

- .1 recommend stability criteria and other measures for ensuring the safe operation of certain types of ships to minimize the risk to such ships, to the personnel on board and to the environment; and
- .2 provide guidelines for stability information, operational provisions against capsizing, icing considerations, considerations for watertight integrity and the determination of lightship parameters.

1.2 Application

1.2.1 This part of the Code contains recommended intact stability criteria for certain types of ships and other marine vehicles not included in part A or intended to supplement those of part A in particular cases regarding size or operation.

1.2.2 Administrations may impose additional requirements regarding the design aspects of ships of novel design or ships not otherwise covered by the Code.

1.2.3 The criteria stated in this part should give guidance to Administrations if no national requirements are applied.

CHAPTER 2 – RECOMMENDED DESIGN CRITERIA FOR CERTAIN TYPES OF SHIPS

2.1 Fishing vessels

2.1.1 Scope

The provisions given hereunder apply to decked seagoing fishing vessels as defined in section 2 (Definitions) of the Introduction. The stability criteria given in 2.1.3 and 2.1.4 below should be complied with for all conditions of loading as specified in 3.4.1.6, unless the Administration is satisfied that operating experience justifies departures therefrom.

2.1.2 General precautions against capsizing

Apart from general precautions referred to in part B, 5.1, 5.2 and 5.3, the following measures should be considered as preliminary guidance on matters influencing safety as related to stability:

- .1 all fishing gear and other heavy material should be properly stowed and placed as low in the vessel as possible;
- .2 particular care should be taken when pull from fishing gear might have a negative effect on stability, e.g., when nets are hauled by power-block or the trawl catches obstructions on the sea-bed. The pull of the fishing gear should be from as low a point on the vessel, above the waterline, as possible;
- .3 gear for releasing the deck load in fishing vessels which carry the catch on deck, e.g., herring, should be kept in good working condition;
- .4 when the main deck is prepared for carrying deck load by dividing it with pound boards, there should be slots between them of suitable size to allow easy flow of water to freeing ports, thus preventing trapping of water;
- .5 to prevent a shift of the fish load carried in bulk, portable divisions in the holds should be properly installed;
- .6 reliance on automatic steering may be dangerous as this prevents changes to course which may be needed in bad weather;
- .7 necessary care should be taken to maintain adequate freeboard in all loading conditions, and where load line regulations are applicable they should be strictly adhered to at all times; and
- .8 particular care should be taken when the pull from fishing gear results in dangerous heel angles. This may occur when fishing gear fastens onto an underwater obstacle or when handling fishing gear, particularly on purse seiners, or when one of the trawl wires tears off. The heel angles caused by the fishing gear in these situations may be eliminated by employing devices which can relieve or remove excessive forces applied through the fishing gear. Such devices should not impose a danger to the vessel through operating in circumstances other than those for which they were intended.

2.1.3 *Recommended general criteria*¹¹

2.1.3.1 The general intact stability criteria given in part A, 2.2.1 to 2.2.3 should apply to fishing vessels having a length of 24 m and over, with the exception of requirements on the initial metacentric height GM (part A, 2.2.4), which, for fishing vessels, should not be less than 0.35 m for single-deck vessels. In vessels with complete superstructure or vessels of 70 m in length and over the metacentric height may be reduced to the satisfaction of the Administration but in no case should be less than 0.15 m.

2.1.3.2 The adoption by individual countries of simplified criteria which apply such basic stability values to their own types and classes of vessels is recognized as a practical and valuable method of economically judging the stability.

2.1.3.3 Where arrangements other than bilge keels are provided to limit the angle of roll, the Administration should be satisfied that the stability criteria referred to in 2.1.3.1 are maintained in all operating conditions.

2.1.4 *Severe wind and rolling criterion (weather criterion) for fishing vessels*

2.1.4.1 The Administration may apply the provisions of part A, 2.3 to fishing vessels of 45 m length and over.

2.1.4.2 For fishing vessels in the length range between 24 m and 45 m, the Administration may apply the provisions of part A, 2.3. Alternatively the values of wind pressure (see part A, 2.3.2) may be taken from the following table:

h (m)	1	2	3	4	5	6 and over
P (Pa)	316	386	429	460	485	504

where h is the vertical distance from the centre of the projected vertical area of the vessel above the waterline, to the waterline.

2.1.5 *Recommendation for an interim simplified stability criterion for decked fishing vessels under 30 m in length*

2.1.5.1 For decked vessels with a length less than 30 m, the following approximate formula for the minimum metacentric height GM_{min} (in metres) for all operating conditions should be used as the criterion:

$$GM_{min} = 0.53 + 2B \left[0.075 - 0.37 \left(\frac{f}{B} \right) + 0.82 \left(\frac{f}{B} \right)^2 - 0.014 \left(\frac{B}{D} \right) - 0.032 \left(\frac{l_s}{L} \right) \right]$$

where:

- L is the length of the vessel on the waterline in maximum load condition (m)
- l_s is the actual length of enclosed superstructure extending from side to side of the vessel (m)

¹¹ Refer to regulation III/2 of the 1993 Torremolinos Protocol.

- B is the extreme breadth of the vessel on the waterline in maximum load condition (m)
- D is the depth of the vessel measured vertically amidships from the base line to the top of the upper deck at side (m)
- f is the smallest freeboard measured vertically from the top of the upper deck at side to the actual waterline (m).

The formula is applicable for vessels having:

- .1 f/B between 0.02 and 0.2;
- .2 l_s/L smaller than 0.6;
- .3 B/D between 1.75 and 2.15;
- .4 sheer fore and aft at least equal to or exceeding the standard sheer prescribed in regulation 38(8) of the International Convention on Load Lines, 1966 or the Protocol of 1988 as amended, as applicable; and
- .5 height of superstructure included in the calculation is not less than 1.8 m.

For ships with parameters outside the above limits the formula should be applied with special care.

2.1.5.2 The above formula is not intended as a replacement for the basic criteria given in 2.1.3 and 2.1.4 but is to be used only if circumstances are such that cross curves of stability, KM curve and subsequent GZ curves are not and cannot be made available for judging a particular vessel's stability.

2.1.5.3 The calculated value of GM, should be compared with actual GM values of the vessel in all loading conditions. If an inclining experiment based on estimated displacement, or another approximate method of determining the actual GM is used, a safety margin should be added to the calculated GM_{min} .

2.2 Pontoons

2.2.1 Application

The provisions given hereunder apply to seagoing pontoons. A pontoon is considered to be normally:

- .1 non self-propelled;
- .2 unmanned;
- .3 carrying only deck cargo;
- .4 having a block coefficient of 0.9 or greater;

- .5 having a breadth/depth ratio of greater than 3; and
- .6 having no hatchways in the deck except small manholes closed with gasketed covers.

2.2.2 *Stability drawings and calculations*

The following information is typical of that required to be submitted to the Administration for approval:

- .1 lines drawing;
- .2 hydrostatic curves;
- .3 cross curves of stability;
- .4 report of draught and density readings and calculation of lightship displacement and longitudinal centre of gravity;
- .5 statement of justification of assumed vertical centre of gravity; and
- .6 simplified stability guidance such as a loading diagram, so that the pontoon may be loaded in compliance with the stability criteria.

2.2.3 *Concerning the performance of calculations*

The following guidance is suggested:

- .1 no account should be taken of the buoyancy of deck cargo (except buoyancy credit for adequately secured timber);
- .2 consideration should be given to such factors as water absorption (e.g., timber), trapped water in cargo (e.g., pipes) and ice accretion;
- .3 in performing wind heel calculations:
 - .3.1 the wind pressure should be constant and for general operations be considered to act on a solid mass extending over the length of the cargo deck and to an assumed height above the deck;
 - .3.2 the centre of gravity of the cargo should be assumed at a point mid-height of the cargo; and
 - .3.3 the wind lever should be taken from the centre of the deck cargo to a point at one half the mean draught;
- .4 calculations should be performed covering the full range of operating draughts; and
- .5 the down-flooding angle should be taken as the angle at which an opening through which progressive flooding may take place is immersed. This would not be an opening closed by a watertight manhole cover or a vent fitted with an automatic closure.

2.2.4 *Intact stability criteria*

2.2.4.1 The area under the righting lever curve up to the angle of maximum righting lever should not be less than 0.08 metre-radians.

2.2.4.2 The static angle of heel due to a uniformly distributed wind load of 540 Pa (wind speed 30 m/s) should not exceed an angle corresponding to half the freeboard for the relevant loading condition, where the lever of wind heeling moment is measured from the centroid of the windage area to half the draught.

2.2.4.3 The minimum range of stability should be:

for $L \leq 100$ m:	20°;
for $L \geq 150$ m:	15°;
for intermediate length:	by interpolation.

2.3 Containerships greater than 100 m

2.3.1 *Application*¹²

These requirements apply to containerships greater than 100 m in length as defined in section 2 (Definitions) of the Introduction. They may also be applied to other cargo ships in this length range with considerable flare or large water plane areas. The Administration may apply the following criteria instead of those in part A, 2.2.

2.3.2 *Intact stability*

2.3.2.1 The area under the righting lever curve (GZ curve) should not be less than $0.009/C$ metre-radians up to $\varphi = 30^\circ$ angle of heel, and not less than $0.016/C$ metre-radians up to $\varphi = 40^\circ$ or the angle of flooding φ_f (as defined in part A, 2.2) if this angle is less than 40° .

2.3.2.2 Additionally, the area under the righting lever curve (GZ curve) between the angles of heel of 30° and 40° or between 30° and φ_f , if this angle is less than 40° , should not be less than $0.006/C$ metre-radians.

2.3.2.3 The righting lever GZ should be at least $0.033/C$ m at an angle of heel equal or greater than 30° .

2.3.2.4 The maximum righting lever GZ should be at least $0.042/C$ m.

2.3.2.5 The total area under the righting lever curve (GZ curve) up to the angle of flooding φ_f should not be less than $0.029/C$ metre-radians.

¹² Since the criteria in this section were empirically developed with the data of containerships less than 200 m in length, they should be applied to ships beyond such limits with special care.

2.3.2.6 In the above criteria the form factor C should be calculated using the formula and figure 2.3-1:

$$C = \frac{d D'}{B_m^2} \sqrt{\frac{d}{KG}} \left(\frac{C_B}{C_W} \right)^2 \sqrt{\frac{100}{L}}$$

where:

d = mean draught (m)

D' = moulded depth of the ship, corrected for defined parts of volumes within the hatch coamings according to the formula:

$$D' = D + h \left(\frac{2b - B_D}{B_D} \right) \left(\frac{2 \sum l_H}{L} \right), \text{ as defined in figure 2.3-1;}$$

D = moulded depth of the ship (m);

B_D = moulded breadth of the ship (m);

KG = height of the centre of mass above base, corrected for free surface effect, not be taken as less than d (m);

C_B = block coefficient;

C_W = water plane coefficient;

l_H = length of each hatch coaming within $L/4$ forward and aft from amidships (m) (see figure 2.3-1);

b = mean width of hatch coamings within $L/4$ forward and aft from amidships (m) (see figure 2.3-1);

h = mean height of hatch coamings within $L/4$ forward and aft from amidships (m) (see figure 2.3-1);

L = length of the ship (m);

B = breadth of the ship on the waterline (m);

B_m = breadth of the ship on the waterline at half mean draught (m).

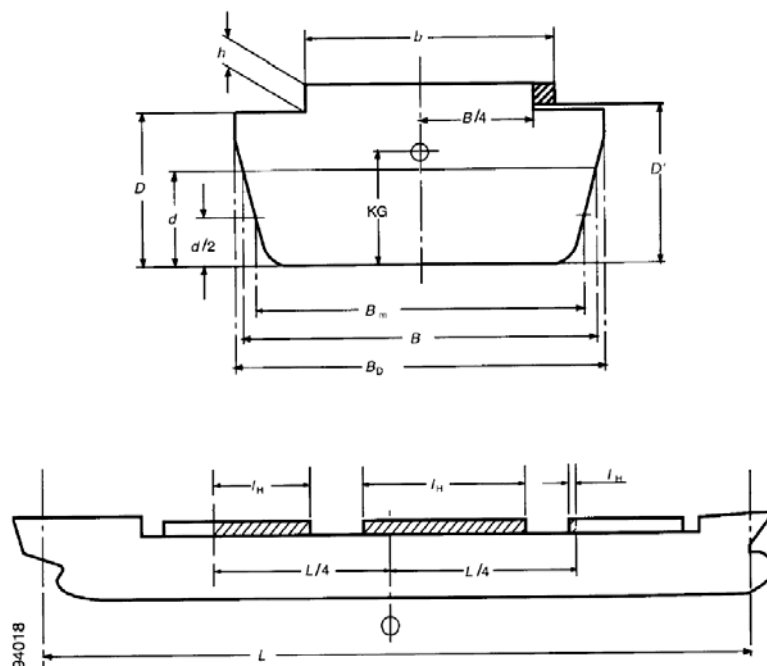

Figure 2.3-1

The shaded areas in figure 2.3-1 represent partial volumes within the hatch coamings considered contributing to resistance against capsizing at large heeling angles when the ship is on a wave crest.

2.3.2.7 The use of electronic loading and stability instrument is encouraged in determining the ship's trim and stability during different operational conditions.

2.4 Offshore supply vessels

2.4.1 Application

2.4.1.1 The provisions given hereunder apply to offshore supply vessels, as defined in section 2 (Definitions) of the Introduction, of 24 m in length and over. The alternative stability criteria contained in 2.4.5 apply to vessels of not more than 100 m in length.

2.4.1.2 For a vessel engaged in near-coastal voyages, as defined in section "Definitions", the principles given in 2.4.2 should guide the Administration in the development of its national standards. Relaxations from the requirements of the Code may be permitted by an Administration for vessels engaged in near-coastal voyages off its own coasts provided the operating conditions are, in the opinion of that Administration, such as to render compliance with the provisions of the Code unreasonable or unnecessary.

2.4.1.3 Where a ship other than an offshore supply vessel, as defined in section "Definitions", is employed on a similar service, the Administration should determine the extent to which compliance with the provisions of the Code is required.

2.4.2 Principles governing near-coastal voyages

2.4.2.1 The Administration defining near-coastal voyages for the purpose of the present Code should not impose design and construction standards for a vessel entitled to fly the flag of another State and engaged in such voyages in a manner resulting in a more stringent standard for

such a vessel than for a vessel entitled to fly its own flag. In no case should the Administration impose, in respect of a vessel entitled to fly the flag of another State, standards in excess of the Code for a vessel not engaged in near-coastal voyages.

2.4.2.2 With respect to a vessel regularly engaged in near-coastal voyages off the coast of another State the Administration should prescribe design and construction standards for such a vessel at least equal to those prescribed by the Government of the State off whose coast the vessel is engaged, provided such standards do not exceed the Code in respect of a vessel not engaged in near-coastal voyages.

2.4.2.3 A vessel which extends its voyages beyond a near-coastal voyage should comply with the present Code.

2.4.3 *Constructional precautions against capsizing*

2.4.3.1 Access to the machinery space should, if possible, be arranged within the forecastle. Any access to the machinery space from the exposed cargo deck should be provided with two weathertight closures. Access to spaces below the exposed cargo deck should preferably be from a position within or above the superstructure deck.

2.4.3.2 The area of freeing ports in the side bulwarks of the cargo deck should at least meet the requirements of regulation 24 of the International Convention on Load Lines, 1966 or the Protocol of 1988 relating thereto, as amended, as applicable. The disposition of the freeing ports should be carefully considered to ensure the most effective drainage of water trapped in pipe deck cargoes or in recesses at the after end of the forecastle. In vessels operating in areas where icing is likely to occur, no shutters should be fitted in the freeing ports.

2.4.3.3 The Administration should give special attention to adequate drainage of pipe stowage positions having regard to the individual characteristics of the vessel. However, the area provided for drainage of the pipe stowage positions should be in excess of the required freeing port area in the cargo deck bulwarks and should not be fitted with shutters.

2.4.3.4 A vessel engaged in towing operations should be provided with means for quick release of the towing hawser.

2.4.4 *Operational procedures against capsizing*

2.4.4.1 The arrangement of cargo stowed on deck should be such as to avoid any obstruction of the freeing ports or of the areas necessary for the drainage of pipe stowage positions to the freeing ports.

2.4.4.2 A minimum freeboard at the stern of at least 0.005 *L* should be maintained in all operating conditions.

2.4.5 *Stability criteria*

2.4.5.1 The stability criteria given in part A, 2.2 should apply to all offshore supply vessels except those having characteristics which render compliance with part A, 2.2 impracticable.

2.4.5.2 The following equivalent criteria should be applied where a vessel's characteristics render compliance with part A, 2.2 impracticable:

- .1 the area under the curve of righting levers (GZ curve) should not be less than 0.07 metre-radians up to an angle of 15° when the maximum righting lever (GZ) occurs at 15° and 0.055 metre-radians up to an angle of 30° when the maximum righting lever (GZ) occurs at 30° or above. Where the maximum righting lever (GZ) occurs at angles of between 15° and 30°, the corresponding area under the righting lever curve should be:

$$0.055 + 0.001 (30^\circ - \varphi_{\max}) \text{ metre-radians}^{13};$$

- .2 the area under the righting lever curve (GZ curve) between the angles of heel of 30° and 40°, or between 30° and φ_f if this angle is less than 40°, should be not less than 0.03 metre-radians;
- .3 the righting lever (GZ) should be at least 0.2 m at an angle of heel equal to or greater than 30°;
- .4 the maximum righting lever (GZ) should occur at an angle of heel not less than 15°;
- .5 the initial transverse metacentric height (GM_0) should not be less than 0.15 m; and
- .6 reference is made also to part A, 2.1.3 to 2.1.5 and part B, 5.1.

2.5 Special purpose ships

2.5.1 Application

The provisions given hereunder apply to special purpose ships, as defined in section 2 (Definitions) of the Introduction, of not less than 500 gross tonnage. The Administration may also apply these provisions as far as reasonable and practicable to special purpose ships of less than 500 gross tonnage.

2.5.2 Stability criteria

The intact stability of special purpose ships should comply with the provisions given in part A, 2.2 except that the alternative criteria given in part B, 2.4.5 which apply to offshore supply vessels may be used for special purpose ships of less than 100 m in length of similar design and characteristics.

2.6 Mobile offshore drilling units (MODUs)

2.6.1 Application

2.6.1.1 The provisions given hereunder apply to mobile offshore drilling units as defined in section 2 (Definitions) of the Introduction, the keels of which are laid or which are at a similar stage of construction on or after 1 May 1991. For MODUs constructed before that date, the corresponding provisions of chapter 3 of resolution A.414(XI) should apply.

¹³ φ_{\max} is the angle of heel in degrees at which the righting lever curve reaches its maximum.

2.6.1.2 The coastal State may permit any unit designed to a lesser standard than that of this chapter to engage in operations, having taken account of the local environmental conditions. Any such unit should, however, comply with safety requirements which in the opinion of the coastal State are adequate for the intended operation and ensure the overall safety of the unit and the personnel on board.

2.6.2 *Righting moment and wind heeling moment curves*

2.6.2.1 Curves of righting moments and of wind heeling moments similar to figure 2.6-1 with supporting calculations should be prepared covering the full range of operating draughts, including those in transit conditions, taking into account the maximum deck cargo and equipment in the most unfavourable position applicable. The righting moment curves and wind heeling moment curves should be related to the most critical axes. Account should be taken of the free surface of liquids in tanks.

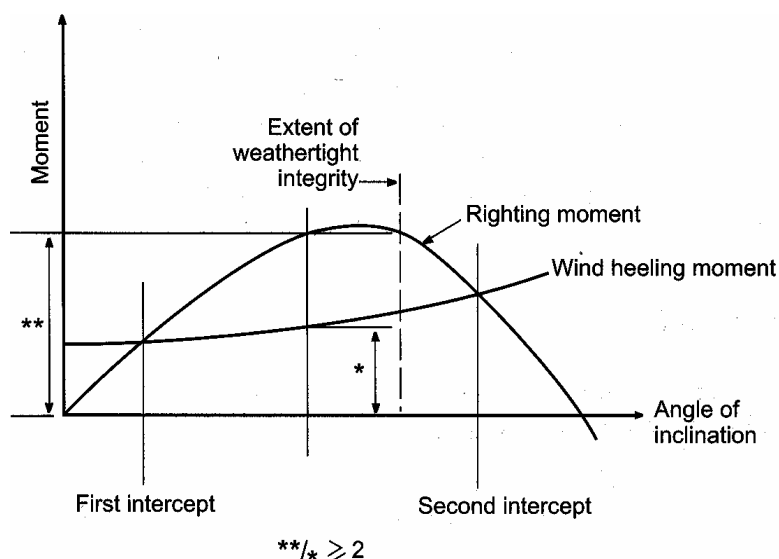

Figure 2.6-1 – Righting moment and wind heeling moment curves

2.6.2.2 Where equipment is of such a nature that it can be lowered and stowed, additional wind heeling moment curves may be required and such data should clearly indicate the position of such equipment.

2.6.2.3 The curves of wind heeling moment should be drawn for wind forces calculated by the following formula:

$$F = 0.5 * C_S * C_H * \rho * V^2 * A$$

where:

- F is the wind force (N)
- C_S is the shape coefficient depending on the shape of the structural member exposed to the wind (see table 2.6.2.3-1)
- C_H is the height coefficient depending on the height above sea level of the structural member exposed to wind (see table 2.6.2.3-2)
- ρ is the air mass density (1.222 kg/m³)

- V is the wind velocity (m/s)
- A is the projected area of all exposed surfaces in either the upright or the heeled condition (m²).

Table 2.6.2.3-1 – Values of the coefficient C_S

Shape	C_S
Spherical	0.40
Cylindrical	0.50
Large flat surface (hull, deck-house, smooth under-deck areas)	1.00
Drilling derrick	1.25
Wires	1.20
Exposed beams and girders under deck	1.30
Small parts	1.40
Isolated shapes (crane, beam, etc.)	1.50
Clustered deck-houses or similar structures	1.10

Table 2.6.2.3-2 – Values of the coefficient C_H

Height above sea level (m)	C_H
0 – 15.3	1
15.3 – 30.5	1.1
30.5 – 46	1.2
46.0 – 61	1.3
61.0 – 76	1.37
76.0 – 91.5	1.43
91.5 – 106.5	1.48
106.5 – 122	1.52
122.0 – 137	1.56
137.0 – 152.5	1.6
152.5 – 167.5	1.63
167.5 – 183	1.67
183.0 – 198	1.7
198.0 – 213.5	1.72
213.5 – 228.5	1.75
228.5 – 244	1.77
244.0 – 256	1.79
Above 256	1.8

2.6.2.4 Wind forces should be considered from any direction relative to the unit and the value of the wind velocity should be as follows:

- .1 in general, a minimum wind velocity of 36 m/s (70 knots) for offshore service should be used for normal operating conditions and a minimum wind velocity of 51.5 m/s (100 knots) should be used for the severe storm conditions; and
- .2 where a unit is to be limited in operation to sheltered locations (protected inland waters such as lakes, bays, swamps, rivers, etc.), consideration should be given to a reduced wind velocity of not less than 25.8 m/s (50 knots) for normal operating conditions.

2.6.2.5 In calculating the projected areas to the vertical plane, the area of surfaces exposed to wind due to heel or trim, such as under decks, etc., should be included, using the appropriate shape factor. Open truss work may be approximated by taking 30% of the projected block area of both the front and back section, i.e. 60% of the projected area of one side.

2.6.2.6 In calculating the wind heeling moments, the lever of the wind overturning force should be taken vertically from the centre of pressure of all surfaces exposed to the wind to the centre of lateral resistance of the underwater body of the unit. The unit is to be assumed floating free of mooring restraint.

2.6.2.7 The wind heeling moment curve should be calculated for a sufficient number of heel angles to define the curve. For ship-shaped hulls the curve may be assumed to vary as the cosine function of ship heel.

2.6.2.8 Wind heeling moments derived from wind-tunnel tests on a representative model of the unit may be considered as alternatives to the method given in 2.6.2.3 to 2.6.2.7. Such heeling moment determination should include lift and drag effects at various applicable heel angles.

2.6.3 *Intact stability criteria*

2.6.3.1 The stability of a unit in each mode of operation should meet the following criteria (see also figure 2.6-2):

- .1 for surface and self-elevating units the area under the righting moment curve to the second intercept or down-flooding angle, whichever is less, should be not less than 40% in excess of the area under the wind heeling moment curve to the same limiting angle;
- .2 for column-stabilized units the area under the righting moment curve to the angle of down-flooding should be not less than 30% in excess of the area under the wind heeling moment curve to the same limiting angle; and
- .3 the righting moment curve should be positive over the entire range of angles from upright to the second intercept.

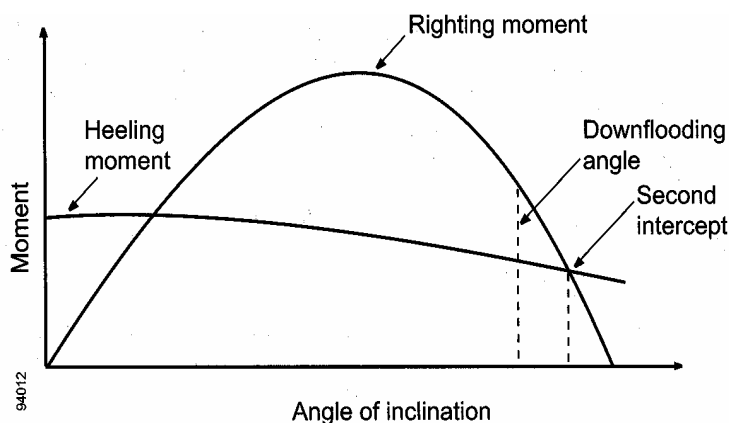

Figure 2.6-2 – Righting moment and heeling moment curves

2.6.3.2 Each unit should be capable of attaining a severe storm condition in a period of time consistent with the meteorological conditions. The procedures recommended and the approximate length of time required, considering both operating conditions and transit conditions, should be contained in the operating manual, as referred to in 3.6.2. It should be possible to achieve the severe storm condition without the removal or relocation of solid consumables or other variable load. However, the Administration may permit loading a unit past the point at which solid consumables would have to be removed or relocated to go to severe storm condition under the following conditions, provided the allowable KG requirement is not exceeded:

- .1 in a geographic location where weather conditions annually or seasonally do not become sufficiently severe to require a unit to go to severe storm condition; or
- .2 where a unit is required to support extra deckload for a short period of time that is well within the bounds of a favourable weather forecast.

The geographic locations and weather conditions and loading conditions when this is permitted should be identified in the operating manual.

2.6.3.3 Alternative stability criteria may be considered by the Administration provided an equivalent level of safety is maintained and if they are demonstrated to afford adequate positive initial stability. In determining the acceptability of such criteria, the Administration should consider at least the following and take into account as appropriate:

- .1 environmental conditions representing realistic winds (including gusts) and waves appropriate for world-wide service in various modes of operation;
- .2 dynamic response of a unit. Analysis should include the results of wind-tunnel tests, wave tank model tests, and non-linear simulation, where appropriate. Any wind and wave spectra used should cover sufficient frequency ranges to ensure that critical motion responses are obtained;
- .3 potential for flooding taking into account dynamic responses in a seaway;
- .4 susceptibility to capsizing considering the unit's restoration energy and the static inclination due to the mean wind speed and the maximum dynamic response; and
- .5 an adequate safety margin to account for uncertainties.

An example of alternative criteria for twin-pontoon column-stabilized semi-submersible units is given in section 2.6.4.

2.6.4 *An example of alternative intact stability criteria for twin-pontoon column-stabilized semi-submersible units*

2.6.4.1 The criteria given below apply only to twin-pontoon column-stabilized semi-submersible units in severe storm conditions which fall within the following ranges of parameters:

V_p/V_t	is between 0.48 and 0.58
$A_{wp}/(V_c)^{2/3}$	is between 0.72 and 1.00
$L_{wp}/[V_c * (L_{ptn}/2)]$	is between 0.40 and 0.70

The parameters used in the above equations are defined in paragraph 2.6.4.3.

2.6.4.2 Intact stability criteria

The stability of a unit in the survival mode of operation should meet the following criteria.

2.6.4.2.1 Capsize criteria

These criteria are based on the wind heeling moment and righting moment curves calculated as shown in section 2.6.2 of the Code at the survival draught. The reserve energy area 'B' should be equal to or greater than 10% of the dynamic response area 'A' as shown in figure 2.6-3.

$$\text{Area 'B'}/\text{Area 'A'} \geq 0.10$$

where:

Area 'A' is the area under the righting moment curve measured from φ_1 to $(\varphi_1 + 1.15 * \varphi_{\text{dyn}})$

Area 'B' is the area under the righting moment curve measured from $(\varphi_1 + 1.15 * \varphi_{\text{dyn}})$ to φ_2

φ_1 is the first intercept with the 100 knot wind moment curve

φ_2 is the second intercept with the 100 knot wind moment curve

φ_{dyn} is the dynamic response angle due to waves and fluctuating wind

$$\varphi_{\text{dyn}} = (10.3 + 17.8 * C)/(1 + GM/(1.46 + 0.28 * BM))$$

$$C = (L_{\text{ptn}}^{5/3} * VCP_{w1} * A_w * V_p * V_c^{1/3})/(L_{wp}^{5/3} * V_t)$$

Parameters used in the above equations are defined in paragraph 2.6.4.3.

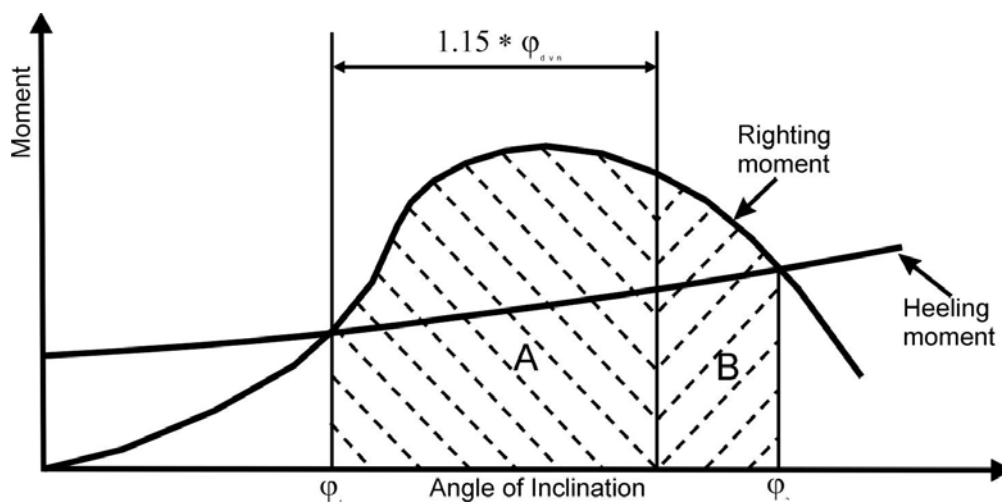

Figure 2.6-3 – Righting moment and heeling moment curves

2.6.4.2.2 Down-flooding criteria

These criteria are based on the physical dimensions of the unit and the relative motion of the unit about a static inclination due to a 75 knot wind measured at the survival draught. The initial down-flooding distance (DFD_0) should be greater than the reduction in down-flooding distance at the survival draught as shown in figure 2.6-4.

$$DFD_0 - RDFD > 0.0$$

where:

- DFD_0 is the initial down-flooding distance to D_m (m)
- $RDFD$ is the reduction in down-flooding distance (m) equal to $SF (k * QSD_1 + RMW)$
- SF is equal to 1.1, which is a safety factor to account for uncertainties in the analysis, such as non-linear effects
- k (correlation factor) is equal to $0.55 + 0.08 * (a - 4) + 0.056 * (1.52 - GM)$; (GM cannot be taken to be greater than 2.44 m)
- a is equal to $(FBD_0/D_m) * (S_{ptn} * L_{cc}) / A_{wp}$ (a cannot be taken to be less than 4)
- QSD_1 is equal to DFD_0 minus quasi-static down-flooding distance at ϕ_1 (m), but not to be taken less than 3 m
- RMW is the relative motion due to waves about ϕ_1 (m), equal to $9.3 + 0.11 * (X - 12.19)$
- X is equal to $D_m * (V_t/V_p) * (A_{wp}^2 / I_{wp}) * (L_{ccc} / L_{ptn})$ (X cannot be taken to be less than 12.19 m).

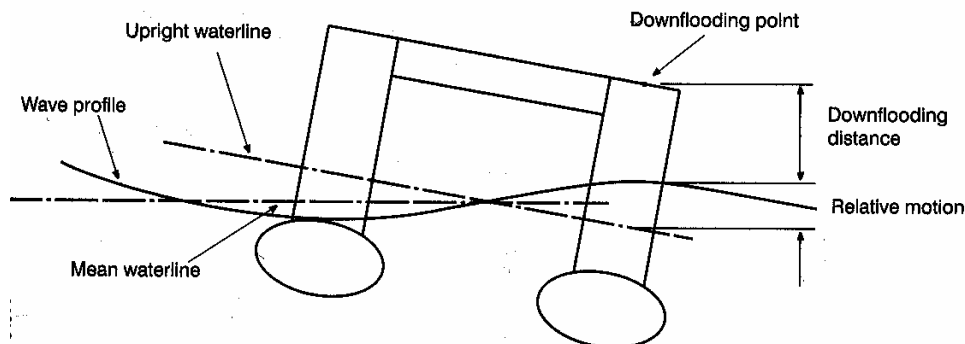

Figure 2.6-4 – Definition of down-flooding distance and relative motion

The parameters used in the above equations are defined in paragraph 2.6.4.3.

2.6.4.3 Geometric parameters

- A_{wp} is the waterplane area at the survival draught, including the effects of bracing members as applicable (m^2).
- A_w is the effective wind area with the unit in the upright position (i.e. the product of projected area, shape coefficient and height coefficient) (m^2).
- BM is the vertical distance from the metacentre to the centre of buoyancy with the unit in the upright position (m).
- D_m is the initial survival draught (m).
- FBD_0 is the vertical distance from D_m , to the top of the upper exposed weathertight deck at the side (m).
- GM for paragraph 2.6.4.2.1, GM is the metacentric height measured about the roll or diagonal axis, whichever gives the minimum reserve energy ratio, 'B'/'A'. This axis is usually the diagonal axis as it possesses a characteristically larger projected wind area which influences the three characteristic angles mentioned above (m).
- GM for paragraph 2.6.4.2.2, GM is the metacentric height measured about the axis which gives the minimum down-flooding distance margin (i.e. generally the direction that gives the largest QSD_1) (m).
- I_{wp} is the water plane second moment of inertia at the survival draught, including the effects of bracing members as applicable (m^4).
- L_{ccc} is the longitudinal distance between centres of the corner columns (m).
- L_{ptn} is the length of each pontoon (m).
- S_{ptn} is the transverse distance between the centrelines of the pontoons (m).
- V_c is the total volume of all columns from the top of the pontoons to the top of the column structure, except for any volume included in the upper deck (m^3).
- V_p is the total combined volume of both pontoons (m^3).
- V_t is the total volume of the structures (pontoons, columns and bracings) contributing to the buoyancy of the unit, from its baseline to the top of the column structure, except for any volume included in the upper deck (m^3).
- VCP_{w1} is the vertical centre of wind pressure above D_m (m).

2.6.4.4 Capsize criteria assessment form

Input data

GM = m

BM = m

$V_{CP_{w1}}$ = m

A_w = m²

V_t = m³

V_c = m³

V_p = m³

I_{wp} = m⁴

L_{ptn} = m

Determine

ϕ_1 = deg

ϕ_2 = deg

$C = (L_{ptn}^{5/3} * V_{CP_{w1}} * A_w * V_p * V_c^{1/3}) / (I_{wp}^{5/3} * V_t) \dots = \dots m^{-1}$

$\phi_{dyn} = (10.3 + 17.8C) / (1 + GM / (1.46 + 0.28BM)) \dots = \dots deg$

Area 'A' = m-deg

Area 'B' = m-deg

Results

Reserve energy ratio:

'B'/'A' = (minimum = 0.1)

GM = m (KG = m)

Note: The minimum GM is that which produces a 'B'/'A' ratio = 0.1

2.6.4.5 Down-flooding criteria assessment form

Input data

DFD₀ = m
 FBD₀ = m
 GM = m
 D_m = m
 V_t = m³
 V_p = m³
 A_{wp} = m²
 I_{wp} = m⁴
 L_{ccc} = m
 L_{ptn} = m
 S_{ptn} = m
 SF = 1.1

Determine

φ₁ = deg
 DFD₁ = m
 QSD₁ = DFD₀ - DFD₁ = m
 a = (FBD₀/D_m)*(S_{ptn} * L_{ccc})/A_{wp} = (a_{min} = 4)
 k = 0.55 + 0.08*(a - 4) + 0.056*(1.52 - GM) = m (GM_{max} = 2.44 m)
 X = D_m*(V_t/V_p)*(A_{wp}²/I_{wp})*(L_{ccc}/L_{ptn}) = m (X_{min} = 12.19 m)
 RMW = 9.3 + 0.11*(X - 12.19) = m
 RDFD = SF*(k * QSD₁ + RMW) = m

Results

Down-flooding margin:

DFD₀ - RDFD = (minimum = 0.0 m)

GM = m (KG = m)

Note: The minimum GM is that which produces a down-flooding margin = 0.0 m.

CHAPTER 3 – GUIDANCE IN PREPARING STABILITY INFORMATION

3.1 Effect of free surfaces of liquids in tanks

3.1.1 For all loading conditions, the initial metacentric height and the righting lever curve should be corrected for the effect of free surfaces of liquids in tanks.

3.1.2 Free surface effects should be considered whenever the filling level in a tank is less than 98% of full condition. Free surface effects need not be considered where a tank is nominally full, i.e. filling level is 98% or above. Free surface effects for small tanks may be ignored under condition specified in 3.1.12.¹⁴

But nominally full cargo tanks should be corrected for free surface effects at 98% filling level. In doing so, the correction to initial metacentric height should be based on the inertia moment of liquid surface at 5° of heeling angle divided by displacement, and the correction to righting lever is suggested to be on the basis of real shifting moment of cargo liquids.

3.1.3 Tanks which are taken into consideration when determining the free surface correction may be in one of two categories:

- .1 tanks with filling levels fixed (e.g., liquid cargo, water ballast). The free surface correction should be defined for the actual filling level to be used in each tank; or
- .2 tanks with filling levels variable (e.g., consumable liquids such as fuel oil, diesel oil and fresh water, and also liquid cargo and water ballast during liquid transfer operations). Except as permitted in 3.1.5 and 3.1.6, the free surface correction should be the maximum value attainable between the filling limits envisaged for each tank, consistent with any operating instructions.

3.1.4 In calculating the free surface effects in tanks containing consumable liquids, it should be assumed that for each type of liquid at least one transverse pair or a single centreline tank has a free surface and the tank or combination of tanks taken into account should be those where the effect of free surfaces is the greatest.

3.1.5 Where water ballast tanks, including anti-rolling tanks and anti-heeling tanks, are to be filled or discharged during the course of a voyage, the free surface effects should be calculated to take account of the most onerous transitory stage relating to such operations.

3.1.6 For ships engaged in liquid transfer operations, the free surface corrections at any stage¹⁵ of the liquid transfer operations may be determined in accordance with the filling level in each tank at that stage of the transfer operation.

3.1.7 The corrections to the initial metacentric height and to the righting lever curve should be addressed separately as follows.

¹⁴ Refer to the intact stability design criteria, contained in MARPOL regulation I/27, together with the associated Unified Interpretation 45.

¹⁵ A sufficient number of loading conditions representing the initial, intermediate and final stages of the filling or discharge operation using the free surface correction at the filling level in each tank at the considered stage may be evaluated to fulfil this recommendation.

3.1.8 In determining the correction to initial metacentric height, the transverse moments of inertia of the tanks should be calculated at 0° angle of heel according to the categories indicated in 3.1.3.

3.1.9 The righting lever curve may be corrected by any of the following methods subject to the agreement of the Administration:

- .1 correction based on the actual moment of fluid transfer for each angle of heel calculated; or
- .2 correction based on the moment of inertia, calculated at 0° angle of heel, modified at each angle of heel calculated.

3.1.10 Corrections may be calculated according to the categories indicated in 3.1.2.

3.1.11 Whichever method is selected for correcting the righting lever curve, only that method should be presented in the ship's stability booklet. However, where an alternative method is described for use in manually calculated loading conditions, an explanation of the differences which may be found in the results, as well as an example correction for each alternative, should be included.

3.1.12 Small tanks which satisfy the following condition corresponding to an angle of inclination of 30°, need not be included in the correction:

$$M_{fs} / \Delta_{min} < 0.01 \text{ m}$$

where:

M_{fs} free surface moment (mt)

Δ_{min} is the minimum ship displacement calculated at d_{min} (t)

d_{min} is the minimum mean service draught of the ship without cargo, with 10% stores and minimum water ballast, if required (m).

3.1.13 The usual remainder of liquids in empty tanks need not be taken into account in calculating the corrections, provided that the total of such residual liquids does not constitute a significant free surface effect.

3.2 Permanent ballast

If used, permanent ballast should be located in accordance with a plan approved by the Administration and in a manner that prevents shifting of position. Permanent ballast should not be removed from the ship or relocated within the ship without the approval of the Administration. Permanent ballast particulars should be noted in the ship's stability booklet.

3.3 Assessment of compliance with stability criteria¹⁶

3.3.1 Except as otherwise required by this Code, for the purpose of assessing in general whether the stability criteria are met, stability curves using the assumptions given in this Code should be drawn for the loading conditions intended by the owner in respect of the ship's operations.

3.3.2 If the owner of the ship does not supply sufficiently detailed information regarding such loading conditions, calculations should be made for the standard loading conditions.

3.4 Standard conditions of loading to be examined

3.4.1 Loading conditions

The standard loading conditions referred to in the text of the present Code are as follows.

3.4.1.1 For a passenger ship:

- .1 ship in the fully loaded departure condition with cargo, full stores and fuel and with the full number of passengers with their luggage;
- .2 ship in the fully loaded arrival condition, with cargo, the full number of passengers and their luggage but with only 10% stores and fuel remaining;
- .3 ship without cargo, but with full stores and fuel and the full number of passengers and their luggage; and
- .4 ship in the same condition as at 0 above with only 10% stores and fuel remaining.

3.4.1.2 For a cargo ship:

- .1 ship in the fully loaded departure condition, with cargo homogeneously distributed throughout all cargo spaces and with full stores and fuel;
- .2 ship in the fully loaded arrival condition with cargo homogeneously distributed throughout all cargo spaces and with 10% stores and fuel remaining;
- .3 ship in ballast in the departure condition, without cargo but with full stores and fuel; and
- .4 ship in ballast in the arrival condition, without cargo and with 10% stores and fuel remaining.

3.4.1.3 For a cargo ship intended to carry deck cargoes:

- .1 ship in the fully loaded departure condition with cargo homogeneously distributed in the holds and with cargo specified in extension and mass on deck, with full stores and fuel; and

¹⁶ Care should be taken in the assessment of compliance with stability criteria, especially conditions in which liquid transfer operations might be expected or anticipated, to insure that the stability criteria is met at all stages of the voyage.

- .2 ship in the fully loaded arrival condition with cargo homogeneously distributed in holds and with a cargo specified in extension and mass on deck, with 10% stores and fuel.

3.4.1.4 For a ship intended to carry timber deck cargoes:

The loading conditions which should be considered for ships carrying timber deck cargoes are specified in 3.4.1.3. The stowage of timber deck cargoes should comply with the provisions of chapter 3 of the Code of Safe Practice for Ships Carrying Timber Deck Cargoes, 1991 (resolution A.715(17)).¹⁷

3.4.1.5 For an offshore supply vessel the standard loading conditions should be as follows:

- .1 vessel in fully loaded departure condition with cargo distributed below deck and with cargo specified by position and weight on deck, with full stores and fuel, corresponding to the worst service condition in which all the relevant stability criteria are met;
- .2 vessel in fully loaded arrival condition with cargo as specified in 3.4.1.5.1, but with 10% stores and fuel;
- .3 vessel in ballast departure condition, without cargo but with full stores and fuel;
- .4 vessel in ballast arrival condition, without cargo and with 10% stores and fuel remaining; and
- .5 vessel in the worst anticipated operating condition.

3.4.1.6 For fishing vessels the standard loading conditions referred to in 2.1.1 are as follows¹⁸:

- .1 departure conditions for the fishing grounds with full fuel, stores, ice, fishing gear, etc.;
- .2 departure from the fishing grounds with full catch and a percentage of stores, fuel, etc., as agreed by the Administration;
- .3 arrival at home port with 10% stores, fuel, etc. remaining and full catch; and
- .4 arrival at home port with 10% stores, fuel, etc. and a minimum catch, which should normally be 20% of full catch but may be up to 40% provided the Administration is satisfied that operating patterns justify such a value.

3.4.2 Assumptions for calculating loading conditions

3.4.2.1 For the fully loaded conditions mentioned in 3.4.1.2.1, 3.4.1.2.2, 3.4.1.3.1 and 3.4.1.3.2 if a dry cargo ship has tanks for liquid cargo, the effective deadweight in the loading conditions therein described should be distributed according to two assumptions, i.e. with cargo tanks full, and with cargo tanks empty.

¹⁷ Refer to chapter VI of the 1974 SOLAS Convention and to part C of chapter VI of the 1974 SOLAS Convention as amended by resolution MSC.22(59).

¹⁸ Refer to regulation III/7 of the 1993 Torremolinos Protocol.

3.4.2.2 In the conditions mentioned in 3.4.1.1.1, 3.4.1.2.1 and 3.4.1.3.1 it should be assumed that the ship is loaded to its subdivision load line or summer load line or if intended to carry a timber deck cargo, to the summer timber load line with water ballast tanks empty.

3.4.2.3 If in any loading condition water ballast is necessary, additional diagrams should be calculated taking into account the water ballast. Its quantity and disposition should be stated.

3.4.2.4 In all cases, the cargo in holds is assumed to be fully homogeneous unless this condition is inconsistent with the practical service of the ship.

3.4.2.5 In all cases, when deck cargo is carried, a realistic stowage mass should be assumed and stated, including the height of the cargo.

3.4.2.6 Considering timber deck cargo the following assumptions are to be made for calculating the loading conditions referred to in 3.4.1.4:

- .1 the amount of cargo and ballast should correspond to the worst service condition in which all the relevant stability criteria of part A 2.2 or the optional criteria given in part A 3.3.2, are met. In the arrival condition, it should be assumed that the weight of the deck cargo has increased by 10% owing to water absorption.

3.4.2.7 For offshore supply vessels, the assumptions for calculating loading conditions should be as follows:

- .1 if a vessel is fitted with cargo tanks, the fully loaded conditions of 3.4.1.5.1 and 3.4.1.5.2 should be modified, assuming first the cargo tanks full and then the cargo tanks empty;
- .2 if in any loading condition water ballast is necessary, additional diagrams should be calculated, taking into account the water ballast, the quantity and disposition of which should be stated in the stability information;
- .3 in all cases when deck cargo is carried a realistic stowage weight should be assumed and stated in the stability information, including the height of the cargo and its centre of gravity;
- .4 where pipes are carried on deck, a quantity of trapped water equal to a certain percentage of the net volume of the pipe deck cargo should be assumed in and around the pipes. The net volume should be taken as the internal volume of the pipes, plus the volume between the pipes. This percentage should be 30 if the freeboard amidships is equal to or less than 0.015 L and 10 if the freeboard amidships is equal to or greater than 0.03 L. For intermediate values of the freeboard amidships the percentage may be obtained by linear interpolation. In assessing the quantity of trapped water, the Administration may take into account positive or negative sheer aft, actual trim and area of operation; or
- .5 if a vessel operates in zones where ice accretion is likely to occur, allowance for icing should be made in accordance with the provisions of chapter 6 (Icing considerations).

3.4.2.8 For fishing vessels the assumptions for calculating loading conditions should be as follows:

- .1 allowance should be made for the weight of the wet fishing nets and tackle, etc., on deck;
- .2 allowance for icing, where this is anticipated to occur, should be made in accordance with the provisions of 6.3;
- .3 in all cases the cargo should be assumed to be homogeneous unless this is inconsistent with practice;
- .4 in conditions referred to in 3.4.1.6.2 and 3.4.1.6.3 deck cargo should be included if such a practice is anticipated;
- .5 water ballast should normally only be included if carried in tanks which are specially provided for this purpose.

3.5 Calculation of stability curves

3.5.1 General

Hydrostatic and stability curves should be prepared for the trim range of operating loading conditions taking into account the change in trim due to heel (free trim hydrostatic calculation). The calculations should take into account the volume to the upper surface of the deck sheathing. Furthermore, appendages and sea chests need to be considered when calculating hydrostatics and cross curves of stability. In the presence of port-starboard asymmetry, the most unfavourable righting lever curve should be used.

3.5.2 Superstructures, deckhouses, etc., which may be taken into account

3.5.2.1 Enclosed superstructures complying with regulation 3(10)(b) of the 1966 Load Line Convention and the Protocol of 1988 relating thereto, as amended, may be taken into account.

3.5.2.2 Additional tiers of similarly enclosed superstructures may also be taken into account. As guidance windows (pane and frame) that are considered without deadlights in additional tiers above the second tier if considered buoyant should be designed with strength to sustain a safety margin¹⁹ with regard to the required strength of the surrounding structure.²⁰

3.5.2.3 Deckhouses on the freeboard deck may be taken into account, provided that they comply with the conditions for enclosed superstructures laid down in regulation 3(10)(b) of the 1966 Load Line Convention and the Protocol of 1988 relating thereto, as amended.

3.5.2.4 Where deckhouses comply with the above conditions, except that no additional exit is provided to a deck above, such deckhouses should not be taken into account; however, any deck openings inside such deckhouses should be considered as closed even where no means of closure are provided.

¹⁹ As a guidance for Administrations a safety margin of 30% should be applied.

²⁰ IMO guidance for testing these windows is to be developed.

3.5.2.5 Deckhouses, the doors of which do not comply with the requirements of regulation 12 of the 1966 Load Line Convention and the Protocol of 1988 relating thereto, as amended, should not be taken into account; however, any deck openings inside the deckhouse are regarded as closed where their means of closure comply with the requirements of regulations 15, 17 or 18 of the 1966 Load Line Convention and the Protocol of 1988 relating thereto, as amended.

3.5.2.6 Deckhouses on decks above the freeboard deck should not be taken into account, but openings within them may be regarded as closed.

3.5.2.7 Superstructures and deckhouses not regarded as enclosed can, however, be taken into account in stability calculations up to the angle at which their openings are flooded (at this angle, the static stability curve should show one or more steps, and in subsequent computations the flooded space should be considered non-existent).

3.5.2.8 In cases where the ship would sink due to flooding through any openings, the stability curve should be cut short at the corresponding angle of flooding and the ship should be considered to have entirely lost its stability.

3.5.2.9 Small openings such as those for passing wires or chains, tackle and anchors, and also holes of scuppers, discharge and sanitary pipes should not be considered as open if they submerge at an angle of inclination more than 30°. If they submerge at an angle of 30° or less, these openings should be assumed open if the Administration considers this to be a source of significant flooding.

3.5.2.10 Trunks may be taken into account. Hatchways may also be taken into account having regard to the effectiveness of their closures.

3.5.3 Calculation of stability curves for ships carrying timber deck cargoes

In addition to the provisions given above, the Administration may allow account to be taken of the buoyancy of the deck cargo assuming that such cargo has a permeability of 25% of the volume occupied by the cargo. Additional curves of stability may be required if the Administration considers it necessary to investigate the influence of different permeabilities and/or assumed effective height of the deck cargo.

3.6 Stability booklet

3.6.1 Stability data and associated plans should be drawn up in the working language of the ship and any other language the Administration may require. Reference is also made to the International Safety Management (ISM) Code, adopted by the Organization by resolution A.741(18). All translations of the stability booklet should be approved.

3.6.2 Each ship should be provided with a stability booklet, approved by the Administration, which contains sufficient information to enable the master to operate the ship in compliance with the applicable requirements contained in the Code. The Administration may have additional requirements. On a mobile offshore drilling unit, the stability booklet may be referred to as an operating manual. The stability booklet may include information on longitudinal strength. This Code addresses only the stability-related contents of the booklet.²¹

²¹ Refer to regulation II-1/22 of the 1974 SOLAS Convention, as amended, regulation 10 of the International Convention on Load Lines, 1966 or the Protocol of 1988 as amended, as applicable and regulation III/10 of the 1993 Torremolinos Protocol.

3.6.3 For ships carrying timber deck cargoes:

- .1 comprehensive stability information should be supplied which takes into account timber deck cargo. Such information should enable the master, rapidly and simply, to obtain accurate guidance as to the stability of the ship under varying conditions of service. Comprehensive rolling period tables or diagrams have proved to be very useful aids in verifying the actual stability conditions;²²
- .2 the Administration may deem it necessary that the master be given information setting out the changes in deck cargo from that shown in the loading conditions, when the permeability of the deck cargo is significantly different from 25% (refer to 3.5.3); and
- .3 conditions should be shown indicating the maximum permissible amount of deck cargo having regard to the lightest stowage rate likely to be met in service.

3.6.4 The format of the stability booklet and the information included will vary dependent on the ship type and operation. In developing the stability booklet, consideration should be given to including the following information²³:

- .1 a general description of the ship;
- .2 instructions on the use of the booklet;
- .3 general arrangement plans showing watertight compartments, closures, vents, downflooding angles, permanent ballast, allowable deck loadings and freeboard diagrams;
- .4 hydrostatic curves or tables and cross curves of stability calculated on a free-trimming basis, for the ranges of displacement and trim anticipated in normal operating conditions;
- .5 capacity plan or tables showing capacities and centres of gravity for each cargo stowage space;
- .6 tank sounding tables showing capacities, centres of gravity, and free surface data for each tank;
- .7 information on loading restrictions, such as maximum KG or minimum GM curve or table that can be used to determine compliance with the applicable stability criteria;
- .8 standard operating conditions and examples for developing other acceptable loading conditions using the information contained in the stability booklet;
- .9 a brief description of the stability calculations done including assumptions;
- .10 general precautions for preventing unintentional flooding;
- .11 information concerning the use of any special cross-flooding fittings with descriptions of damage conditions which may require cross-flooding;

²² Refer to regulation II-1/22 of the 1974 SOLAS Convention, as amended, and regulation 10(2) of the International Convention on Load Lines, 1966 or the Protocol of 1988 relating thereto, as amended, as applicable.

²³ Refer to the Model Loading and Stability Manual (MSC/Circ.920).

- .12 any other necessary guidance for the safe operation of the ship under normal and emergency conditions;
- .13 a table of contents and index for each booklet;
- .14 inclining test report for the ship, or:
 - .14.1 where the stability data is based on a sister ship, the inclining test report of that sister ship along with the lightship measurement report for the ship in question; or
 - .14.2 where lightship particulars are determined by other methods than from inclining of the ship or its sister, a summary of the method used to determine those particulars;
- .15 recommendation for determination of ship's stability by means of an in-service inclining test.

3.6.5 As an alternative to the stability booklet mentioned in 3.6.1, a simplified booklet in an approved form containing sufficient information to enable the master to operate the ship in compliance with the applicable provisions of the Code as may be provided at the discretion of the Administration concerned.

3.7 Operational measures for ships carrying timber deck cargoes

3.7.1 The stability of the ship at all times, including during the process of loading and unloading timber deck cargo, should be positive and to a standard acceptable to the Administration. It should be calculated having regard to:

- .1 the increased weight of the timber deck cargo due to:
 - .1.1 absorption of water in dried or seasoned timber, and
 - .1.2 ice accretion, if applicable (chapter 6 (Icing considerations));
- .2 variations in consumables;
- .3 the free surface effect of liquid in tanks; and
- .4 weight of water trapped in broken spaces within the timber deck cargo and especially logs.

3.7.2 The master should:

- .1 cease all loading operations if a list develops for which there is no satisfactory explanation and it would be imprudent to continue loading;
- .2 before proceeding to sea, ensure that:
 - .2.1 the ship is upright;
 - .2.2 the ship has an adequate metacentric height; and
 - .2.3 the ship meets the required stability criteria.

3.7.3 The masters of ships having a length less than 100 m should also:

- .1 exercise good judgement to ensure that a ship which carries stowed logs on deck has sufficient additional buoyancy so as to avoid overloading and loss of stability at sea;
- .2 be aware that the calculated GM_0 in the departure condition may decrease continuously owing to water absorption by the deck cargo of logs, consumption of fuel, water and stores and ensure that the ship has adequate GM_0 throughout the voyage; and
- .3 be aware that ballasting after departure may cause the ship's operating draught to exceed the timber load line. Ballasting and deballasting should be carried out in accordance with the guidance provided in the Code of Safe Practice for Ships Carrying Timber Deck Cargoes, 1991 (resolution A.715(17)).

3.7.4 Ships carrying timber deck cargoes should operate, as far as possible, with a safe margin of stability and with a metacentric height which is consistent with safety requirements but such metacentric height should not be allowed to fall below the recommended minimum, as specified in part A, 3.3.2.

3.7.5 However, excessive initial stability should be avoided as it will result in rapid and violent motion in heavy seas which will impose large sliding and racking forces on the cargo causing high stresses on the lashings. Operational experience indicates that metacentric height should preferably not exceed 3% of the breadth in order to prevent excessive accelerations in rolling provided that the relevant stability criteria given in part A, 3.3.2 are satisfied. This recommendation may not apply to all ships and the master should take into consideration the stability information obtained from the ship's stability booklet.

3.8 Operating booklets for certain ships

3.8.1 Special purpose ships and novel craft, should be provided with additional information in the stability booklet such as design limitations, maximum speed, worst intended weather conditions or other information regarding the handling of the craft that the master needs to operate the ship safely.

3.8.2 For double hull oil tankers of single cargo tank across design, an operation manual for loading and unloading cargo oil should be provided, including operational procedures of loading and unloading cargo oil and detailed data of the initial metacentric height of the oil tanker and that of free surface correction of liquids in cargo oil tanks and ballast tanks during loading and unloading cargo oil (including ballasting and discharging) and cargo oil washing of tanks.²⁴

3.8.3 The stability booklet of ro-ro passenger ships should contain information concerning the importance of securing and maintaining all closures watertight due to the rapid loss of stability which may result when water enters the vehicle deck and the fact that capsizes can rapidly follow.

²⁴ Refer to the Guidance on intact stability of existing tankers during liquid transfer operations (MSC/Circ.706-MEPC/Circ.304).

CHAPTER 4 – STABILITY CALCULATIONS PERFORMED BY STABILITY INSTRUMENTS

4.1 Stability instruments²⁵

A stability instrument installed onboard should cover all stability requirements applicable to the ship. The software is subject to approval by the Administration. Active and passive systems are defined in 4.1.2. These requirements cover passive systems and the off-line operation mode of active systems only.

4.1.1 *General*

4.1.1.1 The scope of stability calculation software should be in accordance with the approved stability booklet and should at least include all information and perform all calculations or checks as necessary to ensure compliance with the applicable stability requirements.

4.1.1.2 An approved stability instrument is not a substitute for the approved stability booklet, and is used as a supplement to the approved stability booklet to facilitate stability calculations.

4.1.1.3 The input/output information should be easily comparable with the approved stability booklet so as to avoid confusion and possible misinterpretation by the operator.

4.1.1.4 An operation manual should be provided for the stability instrument.

4.1.1.5 The language in which the stability calculation results are displayed and printed out as well as the operation manual is written should be the same as used in the ship's approved stability booklet. A translation into a language considered appropriate may be required.

4.1.1.6 The stability instrument is ship specific equipment and the results of the calculations are only applicable to the ship for which it has been approved.

4.1.1.7 In case of modifications of the ship which cause alterations in the stability booklet, the specific approval of any original stability calculation software is no longer valid. The software should be modified accordingly and re-approved.

4.1.1.8 Any change in software version related to the stability calculation should be reported to and be approved by the Administration.

4.1.2 *Data entry system*

4.1.2.1 A passive system requires manual data entry.

4.1.2.2 An active system replaces partly the manual entry with sensors reading and entering the contents of tanks, etc.

4.1.2.3 Any integrated system which controls or initiates actions based on the sensor-supplied inputs is not within the scope of this Code except the part calculating the stability.

²⁵ Refer to the Guidelines for the approval of stability instruments (MSC.1/Circ.1229).

4.1.3 Types of stability software

Three types of calculations performed by stability software are acceptable depending upon a vessel's stability requirements:

Type 1

Software calculating intact stability only (for vessels not required to meet a damage stability criterion).

Type 2

Software calculating intact stability and checking damage stability on basis of a limit curve (e.g., for vessels applicable to SOLAS part B-1 damage stability calculations, etc.) or previously approved loading conditions.

Type 3

Software calculating intact stability and damage stability by direct application of pre-programmed damage cases for each loading condition (for some tankers, etc.). The results of the direct calculations performed by the stability instrument could be accepted by the Administration even if they differ from the required minimum GM or maximum VCG stated in the approved stability booklet.

Such deviations could be accepted under the condition that all relevant stability requirements will be complied with by the results of the direct calculations.

4.1.4 Functional requirements

4.1.4.1 The stability instrument should present relevant parameters of each loading condition in order to assist the master in his judgement on whether the ship is loaded within the approved limits. The following parameters should be presented for a given loading condition:

- .1 detailed deadweight data items including centre of gravity and free surfaces, if applicable;
- .2 trim, list;
- .3 draught at the draught marks and perpendiculars;
- .4 summary of loading condition displacement, VCG, LCG, TCG, VCB, LCB, TCB, LCF, GM and GM_L ;
- .5 table showing the righting lever versus heeling angle including trim and draught;
- .6 down-flooding angle and corresponding down-flooding opening; and
- .7 compliance with stability criteria: Listings of all calculated stability criteria, the limit values, the obtained values and the conclusions (criteria fulfilled or not fulfilled).

4.1.4.2 If direct damage stability calculations are performed, the relevant damage cases according to the applicable rules should be pre-defined for automatic check of a given loading condition.

4.1.4.3 A clear warning should be given on screen and in hard copy printout if any of the limitations are not complied with.

4.1.4.4 The data should be presented on screen and in hard copy printout in a clear unambiguous manner.

4.1.4.5 The date and time of a saved calculation should be part of the screen display and hard copy printout.

4.1.4.6 Each hard copy printout should contain identification of the calculation program including version number.

4.1.4.7 Units of measurement should be clearly identified and used consistently within a loading calculation.

4.1.5 *Acceptable tolerances*

Depending on the type and scope of programs, the acceptable tolerances should be determined differently, according to 4.1.5.1 or 4.1.5.2. Deviation from these tolerances should not be accepted unless the Administration considers that there is a satisfactory explanation for the difference and that there will be no adverse effect on the safety of the ship.

The accuracy of the results should be determined using an independent program or the approved stability booklet with identical input.

4.1.5.1 Programs which use only pre-programmed data from the approved stability booklet as the basis for stability calculations should have zero tolerances for the printouts of input data.

Output data tolerances should be close to zero, however, small differences associated with calculation rounding or abridged input data are acceptable. Additionally differences associated with the use of hydrostatic and stability data for trims and the method calculating free surface moments that differ from those in the approved stability booklet are acceptable subject to review by the Administration.

4.1.5.2 Programs which use hull form models as their basis for stability calculations should have tolerances for the printouts of basic calculated data established against either data from the approved stability booklet or data obtained using the Administration's approval model.

4.1.6 *Approval procedure*

4.1.6.1 Conditions of approval of the stability instrument

The software approval includes:

- .1 verification of type approval, if any;
- .2 verification that the data used is consistent with the current condition of the ship (refer to 4.1.6.2);

- .3 verification and approval of the test conditions; and
- .4 verification that the software is appropriate for the type of ship and stability calculations required.

The satisfactory operation of the stability instrument is to be verified by testing upon installation (refer to 4.1.8). A copy of the approved test conditions and the operation manual for the stability instrument are to be available on board.

4.1.6.2 Specific approval

4.1.6.2.1 The accuracy of the computational results and actual ship data used by the calculation program for the particular ship on which the program will be installed should be to the satisfaction of the Administration.

4.1.6.2.2 Upon application for data verification, minimum of four loading conditions should be taken from the ship's approved stability booklet, which should be used as the test conditions. For ships carrying liquids in bulk, at least one of the conditions should include partially filled tanks. For ships carrying grain in bulk, one of the grain loading conditions should include a partially filled grain compartment. Within the test conditions each compartment should be loaded at least once. The test conditions normally should cover the range of load draughts from the deepest envisaged loaded condition to the light ballast condition and should include at least one departure and one arrival condition.

4.1.6.2.3 The following data, submitted by the applicant, should be consistent with arrangements and most recently approved lightship characteristics of the ship according to current plans and documentation on file, subject to possible further verification on board:

- .1 identification of the calculation program including version number. Main dimensions, hydrostatic particulars and, if applicable, the ship's profile;
- .2 the position of the forward and aft perpendiculars, and if appropriate, the calculation method to derive the forward and aft draughts at the actual position of the ship's draught marks;
- .3 ship's lightweight and centre of gravity derived from the most recently approved inclining experiment or light weight survey;
- .4 lines plan, offset tables or other suitable presentation of hull form data including all relevant appendages, if necessary to model the ship;
- .5 compartment definitions, including frame spacing, and centres of volume, together with capacity tables (sounding/ullage tables), free surface corrections, if appropriate; and
- .6 cargo and consumables distribution for each loading condition.

Verification by the Administration does not absolve the shipowner of responsibility for ensuring that the information programmed into the stability instrument is consistent with the current condition of the ship and approved stability booklet.

4.1.7 *User manual*

A simple and straightforward user manual written in the same language as the stability booklet should be provided, containing descriptions and instructions, as appropriate, for at least the following:

- .1 installation;
- .2 function keys;
- .3 menu displays;
- .4 input and output data;
- .5 required minimum hardware to operate the software;
- .6 use of the test loading conditions;
- .7 computer-guided dialogue steps; and
- .8 list of warnings.

A user manual in electronic format may be provided in addition to the written manual.

4.1.8 *Installation testing*

4.1.8.1 To ensure correct working of the stability instrument after the final or updated software has been installed, it is the responsibility of the ship's master to have test calculations carried out according to the following pattern in the presence of an Administration's surveyor. From the approved test conditions at least one load case (other than light ship) should be calculated.

Note: Actual loading condition results are not suitable for checking the correct working of the stability instrument.

4.1.8.2 Normally, the test conditions are permanently stored in the stability instrument. Steps to be performed:

- .1 retrieve the test load case and start a calculation run; compare the stability results with those in the documentation;
- .2 change several items of deadweight (tank weights and the cargo weight) sufficiently to change the draught or displacement by at least 10%. The results should be reviewed to ensure that they differ in a logical way from those of the approved test condition;
- .3 revise the above modified load condition to restore the initial test condition and compare the results. The relevant input and output data of the approved test condition should be replicated; and
- .4 alternatively, one or more test conditions should be selected and the test calculations performed by entering all deadweight data for each selected test condition into the program as if it were a proposed loading. The results should be verified as identical to the results in the approved copy of the test conditions.

4.1.9 *Periodical testing*

4.1.9.1 It is the responsibility of the ship's master to check the accuracy of the stability instrument at each annual survey by applying at least one approved test condition. If an Administration's representative is not present for the stability instrument check, a copy of the test condition results obtained by this check should be retained on board as documentation of satisfactory testing for the Administration's representative's verification.

4.1.9.2 At each renewal survey this checking for all approved test loading conditions should be done in the presence of the Administration's representative.

4.1.9.3 The testing procedure should be carried out in accordance with paragraph 4.1.8.

4.1.10 *Other requirements*

4.1.10.1 Protection against unintentional or unauthorized modification of programs and data should be provided.

4.1.10.2 The program should monitor operation and activate an alarm when the program is incorrectly or abnormally used.

4.1.10.3 The program and any data stored in the system should be protected from corruption by loss of power.

4.1.10.4 Error messages with regard to limitations such as filling a compartment beyond capacity or more than once, or exceeding the assigned load line, etc., should be included.

4.1.10.5 If any software related to stability measures such as sea keeping abilities of the vessel, evaluation of in-service inclining experiments and processing the results for further calculation, as well as the evaluation of roll period measurements is installed on board, such software should be reported to the Administration for consideration.

4.1.10.6 Program functionalities should include mass and moment calculations with numerical and graphical presentation of the results, such as initial stability values, righting lever curve, areas under the righting lever curve and range of stability.

4.1.10.7 All input data from automatically measuring sensors, such as gauging devices or draught reading systems should be presented to the user for verification. The user should have the possibility to override faulty readings manually.

CHAPTER 5 – OPERATIONAL PROVISIONS AGAINST CAPSIZING

5.1 General precautions against capsizing

5.1.1 Compliance with the stability criteria does not ensure immunity against capsizing, regardless of the circumstances, or absolve the master from his responsibilities. Masters should therefore exercise prudence and good seamanship having regard to the season of the year, weather forecasts and the navigational zone and should take the appropriate action as to speed and course warranted by the prevailing circumstances.²⁶

5.1.2 Care should be taken that the cargo allocated to the ship is capable of being stowed so that compliance with the criteria can be achieved. If necessary, the amount should be limited to the extent that ballast weight may be required.

5.1.3 Before a voyage commences, care should be taken to ensure that the cargo, cargo handling cranes and sizeable pieces of equipment have been properly stowed or lashed so as to minimize the possibility of both longitudinal and lateral shifting, while at sea, under the effect of acceleration caused by rolling and pitching.²⁷

5.1.4 A ship, when engaged in towing operations, should possess an adequate reserve of stability to withstand the anticipated heeling moment arising from the tow line without endangering the towing ship. Deck cargo on board the towing ship should be so positioned as not to endanger the safe working of the crew on deck or impede the proper functioning of the towing equipment and be properly secured. Tow line arrangements should include towing springs and a method of quick release of the tow.

5.1.5 The number of partially filled or slack tanks should be kept to a minimum because of their adverse effect on stability. The negative effect on stability of filled pool tanks should be taken into consideration.

5.1.6 The stability criteria contained in part A chapter 2 set minimum values, but no maximum values are recommended. It is advisable to avoid excessive values of metacentric height, since these might lead to acceleration forces which could be prejudicial to the ship, its complement, its equipment and to safe carriage of the cargo. Slack tanks may, in exceptional cases, be used as a means of reducing excessive values of metacentric height. In such cases, due consideration should be given to sloshing effects.

5.1.7 Regard should be paid to the possible adverse effects on stability where certain bulk cargoes are carried. In this connection, attention should be paid to the IMO Code of Safe Practice for Solid Bulk Cargoes.

5.2 Operational precautions in heavy weather

5.2.1 All doorways and other openings, through which water can enter into the hull or deckhouses, forecastle, etc., should be suitably closed in adverse weather conditions and accordingly all appliances for this purpose should be maintained on board and in good condition.

²⁶ Refer to the Revised Guidance to the master for avoiding dangerous situations in adverse weather and sea conditions (MSC.1/Circ.1228).

²⁷ Refer to the Guidelines for the preparation of the Cargo Securing Manual (MSC/Circ.745).

5.2.2 Weathertight and watertight hatches, doors, etc., should be kept closed during navigation, except when necessarily opened for the working of the ship and should always be ready for immediate closure and be clearly marked to indicate that these fittings are to be kept closed except for access. Hatch covers and flush deck scuttles in fishing vessels should be kept properly secured when not in use during fishing operations. All portable deadlights should be maintained in good condition and securely closed in bad weather.

5.2.3 Any closing devices provided for vent pipes to fuel tanks should be secured in bad weather.

5.2.4 Fish should never be carried in bulk without first being sure that the portable divisions in the holds are properly installed.

5.3 Ship handling in heavy weather

5.3.1 In all conditions of loading necessary care should be taken to maintain a seaworthy freeboard.

5.3.2 In severe weather, the speed of the ship should be reduced if propeller emergence, shipping of water on deck or heavy slamming occurs.

5.3.3 Special attention should be paid when a ship is sailing in following, quartering or head seas because dangerous phenomena such as parametric resonance, broaching to, reduction of stability on the wave crest, and excessive rolling may occur singularly, in sequence or simultaneously in a multiple combination, creating a threat of capsizing. A ship's speed and/or course should be altered appropriately to avoid the above-mentioned phenomena.²⁸

5.3.4 Reliance on automatic steering may be dangerous as this prevents ready changes to course which may be needed in bad weather.

5.3.5 Water trapping in deck wells should be avoided. If freeing ports are not sufficient for the drainage of the well, the speed of the ship should be reduced or the course changed, or both. Freeing ports provided with closing appliances should always be capable of functioning and are not to be locked.

5.3.6 Masters should be aware that steep or breaking waves may occur in certain areas, or in certain wind and current combinations (river estuaries, shallow water areas, funnel shaped bays, etc.). These waves are particularly dangerous, especially for small ships.

5.3.7 In severe weather, the lateral wind pressure may cause a considerable angle of heel. If anti-heeling measures (e.g., ballasting, use of anti-heeling devices, etc.) are used to compensate for heeling due to wind, changes of the ship's course relative to the wind direction may lead to dangerous angles of heel or capsizing. Therefore, heeling caused by the wind should not be compensated with anti-heeling measures, unless, subject to the approval by the Administration, the vessel has been proven by calculation to have sufficient stability in worst case conditions (i.e. improper or incorrect use, mechanism failure, unintended course change, etc.). Guidance on the use of anti-heeling measures should be provided in the stability booklet.

²⁸ Refer to the Revised Guidance to the master for avoiding dangerous situations in adverse weather and sea conditions (MSC.1/Circ.1228).

5.3.8 Use of operational guidelines for avoiding dangerous situations in severe weather conditions or an on-board computer based system is recommended. The method should be simple to use.

5.3.9 High-speed craft should not be intentionally operated outside the worst intended conditions and limitations specified in the relevant certificates, or in documents referred to therein.

CHAPTER 6 – ICING CONSIDERATIONS

6.1 General

6.1.1 For any ship operating in areas where ice accretion is likely to occur, adversely affecting a ship's stability, icing allowances should be included in the analysis of conditions of loading.

6.1.2 Administrations are advised to take icing into account and are permitted to apply national standards where environmental conditions are considered to warrant a higher standard than those recommended in the following sections.

6.2 Cargo ships carrying timber deck cargoes

6.2.1 The master should establish or verify the stability of his ship for the worst service condition, having regard to the increased weight of deck cargo due to water absorption and/or ice accretion and to variations in consumables.²⁹

6.2.2 When timber deck cargoes are carried and it is anticipated that some formation of ice will take place, an allowance should be made in the arrival condition for the additional weight.

6.3 Fishing vessels

The calculations of loading conditions for fishing vessels (refer to 3.4.2.8) should, where appropriate, include allowance for ice accretion, in accordance with the following provisions.

6.3.1 Allowance for ice accretion³⁰

For vessels operating in areas where ice accretion is likely to occur, the following icing allowance should be made in the stability calculations:

- .1 30 kg per square metre on exposed weather decks and gangways;
- .2 7.5 kg per square metre for projected lateral area of each side of the vessel above the water plane;
- .3 the projected lateral area of discontinuous surfaces of rail, sundry booms, spars (except masts) and rigging of vessels having no sails and the projected lateral area of other small objects should be computed by increasing the total projected area of continuous surfaces by 5% and the static moments of this area by 10%.

Vessels intended for operation in areas where ice is known to occur should be:

- .4 designed to minimize the accretion of ice; and
- .5 equipped with such means for removing ice as the Administration may require; for example, electrical and pneumatic devices, and/or special tools such as axes or wooden clubs for removing ice from bulwarks, rails and erections.

²⁹ Refer to regulation 44(10) of the 1966 Load Line Convention and regulation 44(7) of the 1988 Load Line Protocol as amended.

³⁰ Refer to regulation III/8 of the 1993 Torremolinos Protocol.

6.3.2 Guidance relating to ice accretion

In the application of the above standards, the following icing areas should apply:

- .1 the area north of latitude 65° 30' N, between longitude 28° W and the west coast of Iceland; north of the north coast of Iceland; north of the rhumb line running from latitude 66° N, longitude 15° W to latitude 73° 30' N, longitude 15° E, north of latitude 73° 30' N between longitude 15° E and 35° E, and east of longitude 35° E, as well as north of latitude 56° N in the Baltic Sea;
- .2 the area north of latitude 43° N bounded in the west by the North American coast and the east by the rhumb line running from latitude 43° N, longitude 48° W to latitude 63° N, longitude 28° W and thence along longitude 28° W;
- .3 all sea areas north of the North American Continent, west of the areas defined in 6.3.2.1 and 6.3.2.2;
- .4 the Bering and Okhotsk Seas and the Tartary Strait during the icing season; and
- .5 south of latitude 60° S.

A chart to illustrate the areas is attached at the end of this chapter.

For vessels operating in areas where ice accretion may be expected:

- .6 within the areas defined in 6.3.2.1, 6.3.2.3, 6.3.2.4 and 6.3.2.5 known to having icing conditions significantly different from those described in 6.3.1, ice accretion requirements of one half to twice the required allowance may be applied; and
- .7 within the area defined in 6.3.2.2, where ice accretion in excess of twice the allowance required by 6.3.1 may be expected, more severe requirements than those given in 6.3.1 may be applied.

6.3.3 Brief survey of the causes of ice formation and its influence upon the seaworthiness of the vessel

6.3.3.1 The skipper of a fishing vessel should bear in mind that ice formation is a complicated process which depends upon meteorological conditions, condition of loading and behaviour of the vessel in stormy weather as well as on the size and location of superstructures and rigging. The most common cause of ice formation is the deposit of water droplets on the vessel's structure. These droplets come from spray driven from wave crests and from ship-generated spray.

6.3.3.2 Ice formation may also occur in conditions of snowfall, sea fog (including arctic sea smoke), a drastic fall in ambient temperature, as well as from the freezing of drops of rain on impact with the vessel's structure.

6.3.3.3 Ice formation may sometimes be caused or accentuated by water shipped on board and retained on deck.

6.3.3.4 Intensive ice formation generally occurs on stem, bulwark and bulwark rail, front walls of superstructures and deck-houses, hawse holes, anchors, deck gear, forecastle deck and upper deck, freeing ports, aerials, stays, shrouds, masts and spars.

6.3.3.5 It should be borne in mind that the most dangerous areas as far as ice formation is concerned are the sub-Arctic regions.

6.3.3.6 The most intensive ice formation takes place when wind and sea come from ahead. In beam and quartering winds, ice accumulates quicker on the windward side of the vessel, thus leading to a constant list which is extremely dangerous.

6.3.3.7 Listed below are meteorological conditions causing the most common type of ice formation due to spraying of a vessel. Examples of the weight of ice formation on a typical fishing vessel of displacement in the range 100 t to 500 t are also given. For larger vessels the weight will be correspondingly greater.

6.3.3.8 Slow accumulations of ice take place:

- .1 at ambient temperature from -1°C to -3°C and any wind force;
- .2 at ambient temperature -4°C and lower and wind force from 0 m/s to 9 m/s; and
- .3 under the conditions of precipitation, fog or sea mist followed by a drastic fall of the ambient temperature.

Under all these conditions the intensity of ice accumulation may not exceed 1.5 t/h.

6.3.3.9 At ambient temperature of -4°C to -8°C and wind force 10 m/s to 15 m/s, rapid accumulation of ice takes place. Under these conditions the intensity of ice accumulation can lie within the range 1.5 t/h to 4 t/h.

6.3.3.10 Very fast accumulation of ice takes place:

- .1 at ambient temperature of -4°C and lower and wind forces of 16 m/s and over; and
- .2 at ambient temperature -9°C and lower and wind force 10 m/s to 15 m/s.

Under these conditions the intensity of ice accumulation can exceed 4 t/h.

6.3.3.11 The skipper should bear in mind that ice formation adversely affects the seaworthiness of the vessel as ice formation leads to:

- .1 an increase in the weight of the vessel due to accumulation of ice on the vessel's surfaces which causes the reduction of freeboard and buoyancy;
- .2 a rise of the vessel's centre of gravity due to the high location of ice on the vessel's structures with corresponding reduction in the level of stability;
- .3 an increase of windage area due to ice formation on the upper parts of the vessel and hence an increase in the heeling moment due to the action of the wind;

- .4 a change of trim due to uneven distribution of ice along the vessel's length;
- .5 the development of a constant list due to uneven distribution of ice across the breadth of the vessel; and
- .6 impairment of the manoeuvrability and reduction of the speed of the vessel.

6.3.4 Operational procedures related to ensuring a fishing vessel's endurance in conditions of ice formation are given in annex 2 (Recommendations for skippers of fishing vessels on ensuring a vessel's endurance in conditions of ice formation).

6.4 Offshore supply vessels 24 m to 100 m in length

For vessels operating in areas where ice accretion is likely to occur:

- .1 no shutters should be fitted in the freeing ports; and
- .2 with regard to operational precautions against capsizing, reference is made to the recommendations for skippers of fishing vessels on ensuring a vessel's endurance in conditions of ice formation, as given in paragraph 6.3.3 and in annex 2 (Recommendations for skippers of fishing vessels on ensuring a vessel's endurance in conditions of ice formation).

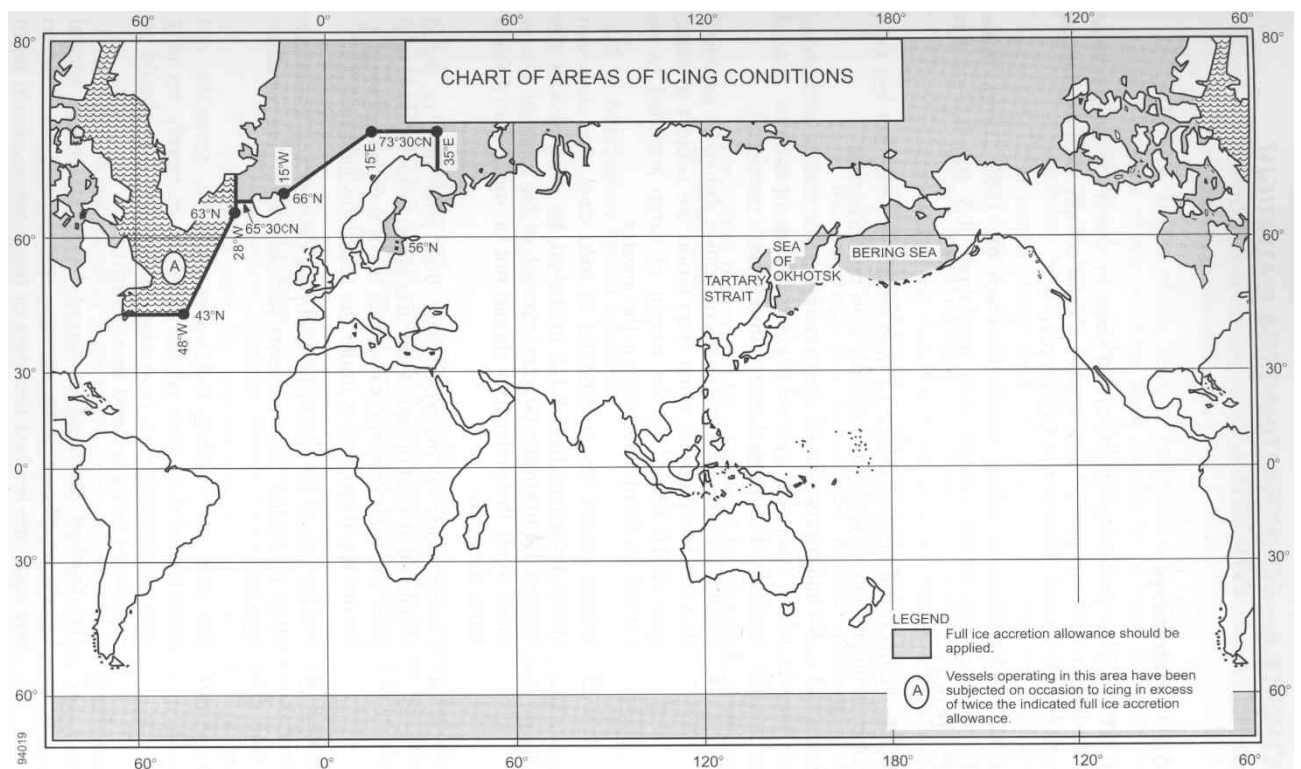

CHAPTER 7 – CONSIDERATIONS FOR WATERTIGHT AND WEATHERTIGHT INTEGRITY

7.1 Hatchways

7.1.1 Cargo and other hatchways in ships to which the International Convention on Load Lines, 1966, applies should comply with regulations 13, 14, 15, 16 and 26(5) of this Convention.

7.1.2 Hatchways in fishing vessels to which the 1993 Torremolinos Protocol applies should comply with regulations II/5 and II/6 of this Protocol.

7.1.3 In decked fishing vessels of 12 m in length and over but less than 24 m in length hatchways should comply with the following:

7.1.3.1 All hatchways should be provided with covers and those which may be opened during fishing operations should normally be arranged near to the vessel's centreline.

7.1.3.2 For the purpose of strength calculations it should be assumed that hatchway covers other than wood are subject to static load of 10 kN/m^2 or the weight of cargo intended to be carried on them, whichever is the greater.

7.1.3.3 Where covers are constructed of mild steel, the maximum stress according to 7.1.3.2 multiplied by 4.25 should not exceed the minimum ultimate strength of the material. Under these loads the deflections should not be more than 0.0028 times the span.

7.1.3.4 Covers made of materials other than mild steel or wood should be at least of equivalent strength to those made of mild steel and their construction should be of sufficient stiffness to ensure weathertightness under the loads specified in 7.1.3.2.

7.1.3.5 Covers should be fitted with clamping devices and gaskets or other equivalent arrangements sufficient to ensure weathertightness.

7.1.3.6 The use of wooden hatchway covers is generally not recommended in view of the difficulty of rapidly securing their weathertightness. However, where fitted they should be capable of being secured weathertight.

7.1.3.7 The finished thickness of wood hatchway covers should include an allowance for abrasion due to rough handling. In any case, the finished thickness of these covers should be at least 4 mm for each 100 mm of unsupported span subject to a minimum of 40 mm and the width of their bearing surfaces should be at least 65 mm.

7.1.3.8 The height above deck of hatchway coamings on exposed parts of the working deck should be at least 300 mm for vessels of 12 m in length and at least 600 mm for vessels of 24 m in length. For vessels of intermediate length the minimum height should be obtained by linear interpolation. The height above deck of hatchway coamings on exposed parts of the superstructure deck should be at least 300 mm.

7.1.3.9 Where operating experience has shown justification and on approval of the competent authority the height of hatchway coamings, except those which give direct access to machinery spaces may be reduced from the height as specified in 7.1.3.8 or the coamings may be omitted entirely, provided that efficient watertight hatch covers other than wood are fitted. Such hatchways

should be kept as small as practicable and the covers should be permanently attached by hinges or equivalent means and be capable of being rapidly closed or battened down.

7.2 Machinery space openings

7.2.1 In ships to which the International Convention on Load Lines, 1966 or the Protocol of 1988 relating thereto as amended, as applicable, applies, machinery space openings should comply with regulation 17.

7.2.2 In fishing vessels to which the 1993 Torremolinos Protocol applies and in new decked fishing vessels of 12 m in length and over, but less than 24 m in length, the following requirements of regulation II/7 of this Protocol should be met:

- .1 machinery space openings should be framed and enclosed by casings of a strength equivalent to the adjacent superstructure. External access openings therein should be fitted with doors complying with the requirements of regulation II/4 of the Protocol or, in vessels less than 24 m in length, with hatch covers other than wood complying with the requirements of 7.1.3 of this chapter; and
- .2 openings other than access openings should be fitted with covers of equivalent strength to the unpierced structure, permanently attached thereto and capable of being closed weathertight.

7.2.3 In offshore supply vessels, access to the machinery space should, if possible, be arranged within the forecabin. Any access to the machinery space from the exposed cargo deck should be provided with two weathertight closures. Access to spaces below the exposed cargo deck should preferably be from a position within or above the superstructure deck.

7.3 Doors

7.3.1 In passenger ships to which the International Convention for the Safety of Life at Sea, 1974, applies, doors should comply with regulations II-1/13 and 16 of this Convention.

7.3.2 In ships to which the International Convention on Load Lines, 1966 or the Protocol of 1988 relating thereto, as amended, as applicable, applies, doors should comply with regulation 12 of this Convention.

7.3.3 In fishing vessels to which the 1993 Torremolinos Protocol applies, doors should comply with regulation II/2 and regulation II/4 of this Protocol.

7.3.4 In decked fishing vessels of 12 m in length and over but less than 24 m in length:

- .1 Watertight doors may be of the hinged type and should be capable of being operated locally from each side of the door. A notice should be attached to the door on each side stating that the door should be kept closed at sea.
- .2 All access openings in bulkheads of enclosed deck erections, through which water could enter and endanger the vessel, should be fitted with doors permanently attached to the bulkhead, framed and stiffened so that the whole structure is of equivalent strength to the unpierced structure, and weathertight when closed, and means should be provided so that they can be operated from each side of the bulkhead.

- .3 The height above deck of sills in those doorways, companionways, deck erections and machinery casings situated on the working deck and on superstructure decks which give direct access to parts of that deck exposed to the weather and sea should be at least equal to the height of hatchway coamings as specified in 7.1.3.8.
- .4 Where operating experience has shown justification and on approval of the competent authority, the height above deck of sills in the doorways specified in 7.3.4.3 except those giving direct access to machinery spaces, may be reduced to not less than 150 mm on superstructure decks and not less than 380 mm on the working deck for vessels 24 m in length, or not less than 150 mm on the working deck for vessels of 12 m in length. For vessels of intermediate length the minimum acceptable reduced height for sills in doorways on the working deck should be obtained by linear interpolation.

7.4 Cargo ports and other similar openings

7.4.1 Cargo ports and other similar openings in ships to which the International Convention on Load Lines, 1966 or the Protocol of 1988 relating thereto, as amended, as applicable, applies should comply with regulation 21 of this Convention.

7.4.2 Openings through which water can enter the vessel and fish flaps on stern trawlers in fishing vessels to which the 1993 Torremolinos Protocol applies should comply with regulation II/3 of this Protocol.

7.4.3 Cargo port and other similar openings in passenger ships to which the International Convention for the Safety of Life at Sea, 1974 applies should comply with regulations II-1/15, 17 and 22 of this Convention. In addition, such openings in ro-ro passenger ships to which this Convention applies, should comply with regulation II-1/17-1 of this Convention.

7.4.4 Cargo port and other similar openings in cargo ships to which the International Convention for the Safety of Life at Sea, 1974 applies should comply with regulation II-1/15-1 of this Convention.

7.5 Sidescuttles, window scuppers, inlets and discharges

7.5.1 In passenger ships to which the International Convention for the Safety of Life at Sea, 1974 applies, openings in shell plating below the bulkhead deck should comply with regulation II-1/15 of this Convention.

Watertight integrity above the bulkhead deck should comply with regulation II-1/17 of this Convention.

In addition, in ro-ro passenger ships, watertight integrity below the bulkhead deck should comply with regulation II-1/23 and integrity of the hull and superstructure should comply with regulation II-1/17-1 of this Convention.

7.5.2 In ships to which the International Convention on Load Lines, 1966 or the Protocol of 1988 relating thereto, as amended, as applicable, applies, scuppers, inlets and discharges should comply with regulation 22 and sidescuttles should comply with regulation 23 of this Convention.

7.5.3 In fishing vessels to which the 1993 Torremolinos Protocol applies, sidescuttles and windows should comply with regulation II/12 and inlets and discharges should comply with regulation II/13 of this Protocol.

7.5.4 In decked fishing vessels of 12 m in length and over but less than 24 m in length, sidescuttles, windows and other openings and inlets and discharges should comply with the following:

- .1 sidescuttles to spaces below the working deck and to enclosed spaces on the working deck should be fitted with hinged deadlights capable of being closed watertight;
- .2 sidescuttles should be fitted in a position such that their sills are above a line drawn parallel to the working deck at side having its lowest point 500 mm above the deepest operating waterline;
- .3 sidescuttles, together with their glasses and deadlights, should be of substantial construction to the satisfaction of the competent authority;
- .4 skylights leading to spaces below the working deck should be of substantial construction and capable of being closed and secured weathertight, and with provision for adequate means of closing in the event of damage to the inserts. Skylights leading to machinery spaces should be avoided as far as practicable;
- .5 toughened safety glass or suitable permanently transparent material of equivalent strength should be fitted in all wheelhouse windows exposed to the weather. The means of securing windows and the width of the bearing surfaces should be adequate, having regard to the window material used. Openings leading to spaces below deck from a wheelhouse whose windows are not provided with the protection required by 0 should be fitted with a weathertight closing appliance;
- .6 deadlights or a suitable number of storm shutters should be provided where there is no other method of preventing water from entering the hull through a broken window or sidescuttle;
- .7 the competent authority may accept sidescuttles and windows without deadlights in side or aft bulkheads of deck erections located on or above the working deck if satisfied that the safety of the vessel will not be impaired;
- .8 the number of openings in the sides of the vessel below the working deck should be the minimum compatible with the design and proper working of the vessel and such openings should be provided with closing arrangements of adequate strength to ensure watertightness and the structural integrity of the surrounding structure;
- .9 discharges led through the shell either from spaces below the working deck or from spaces within deck erections should be fitted with efficient and accessible means for preventing water from passing inboard. Normally each separate discharge should have an automatic non-return valve with a positive means of closing it from a readily accessible position. Such a valve is not required if the competent authority considers that the entry of water into the vessel through the opening is not likely to lead to dangerous flooding and that the thickness of the

pipe is sufficient. The means for operating the valve with a positive means of closing should be provided with an indicator showing whether the valve is open or closed. The open inboard end of any discharge system should be above the deepest operating waterline at an angle of heel satisfactory to the competent authority;

- .10 in machinery spaces main and auxiliary sea inlets and discharges essential for the operation of machinery should be controlled locally. Controls should be readily accessible and should be provided with indicators showing whether the valves are open or closed. Suitable warning devices should be incorporated to indicate leakage of water into the space; and
- .11 fittings attached to the shell and all valves should be of steel, bronze or other ductile material. All pipes between the shell and valves should be of steel, except that in vessels constructed of material other than steel, other suitable materials may be used.

7.5.5 In cargo ships to which the International Convention for the Safety of Life at Sea, 1974 applies, external openings should comply with regulation II-1/15-1 of this Convention.

7.6 Other deck openings

7.6.1 Miscellaneous openings in freeboard and superstructure decks in ships to which the International Convention on Load Lines, 1966 or the Protocol of 1988 relating thereto, as amended, as applicable, applies should comply with regulation 18 of this Convention.

7.6.2 In decked fishing vessels of 12 m and over where it is essential for fishing operations, flush deck scuttles of the screw, bayonet or equivalent type and manholes may be fitted provided these are capable of being closed watertight and such devices should be permanently attached to the adjacent structure. Having regard to the size and disposition of the openings and the design of the closing devices, metal-to-metal closures may be fitted if they are effectively watertight. Openings other than hatchways, machinery space openings, manholes and flush scuttles in the working or superstructure deck should be protected by enclosed structures fitted with weathertight doors or their equivalent. Companionways should be situated as close as practicable to the centreline of the vessel.³¹

7.7 Ventilators, air pipes and sounding devices

7.7.1 Ventilators in ships to which the International Convention on Load Lines, 1966 or the Protocol of 1988 relating thereto, as amended, as applicable, applies should comply with regulation 19 and air pipes should comply with regulation 20 of this Convention.

7.7.2 Ventilators in fishing vessels to which the 1993 Torremolinos Protocol applies should comply with regulation II/9 and air pipes should comply with regulation II/10 of this Protocol. Sounding devices should comply with regulation II/11 of this Protocol.

³¹ Refer to regulation II/8 of the 1993 Torremolinos Protocol.

7.7.3 Ventilators and air pipes in fishing vessels of 12 m in length and over but less than 24 m in length should comply with the following:

- .1 ventilators should have coamings of substantial construction and should be capable of being closed weathertight by devices permanently attached to the ventilator or adjacent structure. Ventilators should be arranged as close to the vessel's centreline as possible and, where practicable, should extend through the top of a deck erection or companionway;
- .2 the coamings of ventilators should be as high as practicable. On the working deck the height above deck of coamings of ventilators, other than machinery space ventilators, should be not less than 760 mm and on superstructure decks not less than 450 mm. When the height of such ventilators may interfere with the working of the vessel their coaming heights may be reduced to the satisfaction of the competent authority. The height above deck of machinery space ventilator openings should be to the satisfaction of the competent authority;
- .3 closing appliances need not be fitted to ventilators the coamings of which extend more than 2.5 m above the working deck or more than 1.0 m above a deck-house top or superstructure deck;
- .4 where air pipes to tanks or other spaces below deck extend above the working or superstructure decks the exposed parts of the pipes should be of substantial construction and, as far as is practicable, located close to the vessel's centreline and protected from damage by fishing or lifting gear. Openings of such pipes should be protected by efficient means of closing, permanently attached to the pipe or adjacent structure, except that where the competent authority is satisfied that they are protected against water trapped on deck, these means of closing may be omitted; and
- .5 where air pipes are situated near the side of the vessel their height above deck to the point where water may have access below should be at least 760 mm on the working deck and at least 450 mm on the superstructure deck. The competent authority may accept reduction of the height of an air pipe to avoid interference with the fishing operations.

7.7.4 In offshore supply vessels air pipes and ventilators should comply with the following:

- .1 air pipes and ventilators should be fitted in protected positions in order to avoid damage by cargo during operations and to minimize the possibility of flooding. Air pipes on the exposed cargo and forecastle decks should be fitted with automatic closing devices; and
- .2 due regard should be given to the position of machinery space ventilators. Preferably they should be fitted in a position above the superstructure deck, or above an equivalent level if no superstructure deck is fitted.

7.8 Freeing ports

7.8.1 Where bulwarks on the weather portion of the freeboard or superstructure decks or, in fishing vessels, the working decks form wells, freeing ports should be arranged along the length of the bulwark as to ensure that the deck is freed of water most rapidly and effectively. Lower edges of freeing ports should be as near the deck as practicable.³²

7.8.2 In ships to which the International Convention on Load Lines, 1966 or the Protocol of 1988 relating thereto as amended, as applicable, applies, freeing ports should comply with regulation 24 of this Convention.

7.8.3 In decked fishing vessels of 12 m in length and over, freeing ports should comply with the following³³.

7.8.3.1 The minimum freeing port area A in m^2 , on each side of the vessel for each well on the working deck, should be determined in relation to the length l and height of bulwark in the well as follows:

.1 $A = K * l$

where:

$K = 0.07$ for vessels of 24 m in length and over

$K = 0.035$ for vessels of 12 m in length;
for intermediate lengths the value of K should be obtained by linear interpolation (l need not be taken as greater than 70% of the vessel's length);

.2 where the bulwark is more than 1.2 m in average height, the required area should be increased by 0.004 m^2 per metre of length of well for each 0.1 m difference in height; and

.3 where the bulwark is less than 0.9 m in average height, the required area may be decreased by 0.004 m^2 per metre of length of well for each 0.1 m difference in height.

7.8.3.2 The freeing port area calculated according to 7.8.3.1 should be increased where the Administration or competent authority considers that the vessel's sheer is not sufficient to ensure rapid and effective freeing of the deck of water.

7.8.3.3 Subject to the approval of the Administration or competent authority, the minimum freeing port area for each well on the superstructure deck should be not less than one-half the area A given in 7.8.3.1 except that where the superstructure deck forms a working deck for fishing operations the minimum area on each side should be not less than 75% of the area A .

³² Refer to regulation 24(5) of the International Convention on Load Lines, 1966 or the Protocol of 1988 as amended, as applicable and regulation 11/14(4) of the 1993 Torremolinos Protocol.

³³ Refer to regulation II/14 of the 1993 Torremolinos Protocol.

7.8.3.4 Freeing ports should be so arranged along the length of bulwarks as to provide the most rapid and effective freeing of the deck from water. Lower edges of freeing ports should be as near the deck as practicable.

7.8.3.5 Pound boards and means for stowage and working the fishing gear should be arranged so that the effectiveness of the freeing ports will not be impaired or water trapped on deck and prevented from easily reaching the freeing ports. Pound boards should be so constructed that they can be locked in position when in use and will not hamper the discharge of shipped water.

7.8.3.6 Freeing ports over 0.3 m in depth should be fitted with bars spaced not more than 0.23 m nor less than 0.15 m apart or provided with other suitable protective arrangements. Freeing port covers, if fitted, should be of approved construction. If devices are considered necessary for locking freeing port covers during fishing operations they should be to the satisfaction of the competent authority and easily operable from a readily accessible position.

7.8.3.7 In vessels intended to operate in areas subject to icing, covers and protective arrangements for freeing ports should be capable of being easily removed to restrict ice accumulation. Size of opening and means provided for removal of these protective arrangements should be to the satisfaction of the competent authority.

7.8.3.8 In addition, in fishing vessels of 12 m in length and above but less than 24 m in length where wells or cockpits are fitted in the working deck or superstructure deck with their bottoms above the deepest operating waterline, efficient non-return means of drainage overboard should be provided. Where bottoms of such wells or cockpits are below the deepest operating waterline, drainage to the bilges should be provided.

7.8.4 In offshore supply vessels, the Administration should give special attention to adequate drainage of pipe stowage positions, having regard to the individual characteristics of the vessel. However, the area provided for drainage of the pipe stowage positions should be in excess of the required freeing port area in the cargo deck bulwark and should not be fitted with shutters.

7.9 Miscellaneous

7.9.1 Ships engaged in towing operations should be provided with means for quick release of the towing hawser.

CHAPTER 8 – DETERMINATION OF LIGHTSHIP PARAMETERS

8.1 Application

8.1.1 Every passenger ship regardless of size and every cargo ship having a length, as defined in the International Convention on Load Lines, 1966 or the Protocol of 1988 relating thereto, as amended, as applicable, of 24 m and upwards, should be inclined upon its completion and the elements of its stability determined.³⁴

8.1.2 The Administration may allow the inclining test of an individual ship as required by paragraph 8.1.1 to be dispensed with provided basic stability data are available from the inclining test of a sister ship and it is shown to the satisfaction of the Administration that reliable stability information for the exempted ship can be obtained from such basic data.

To be dispensed from an inclining test, the deviation of lightship mass is not to exceed,

- | | |
|------------------------|--|
| for $L^{35} < 50$ m: | 2% of the lightship mass of the lead ship or as given in the information on stability; |
| for $L > 160$ m: | 1% of the lightship mass of the lead ship or as given in the information on stability; |
| for intermediate L : | by linear interpolation, |

and the deviation of the lightship's longitudinal centre of gravity (LCG) referred to L should not be greater than 0.5% of the lightship's LCG of the lead ship or as given in the information on stability regardless of the ship's length.

8.1.3 The Administration may allow the inclining test of an individual ship or class of ships especially designed for the carriage of liquids or ore in bulk to be dispensed with when reference to existing data for similar ships clearly indicates that due to the ship's proportions and arrangements more than sufficient metacentric height will be available in all probable loading conditions.

8.1.4 Where any alterations are made to a ship so as to materially affect the stability, the ship should be re-inclined.

8.1.5 At periodic intervals not exceeding five years, a lightweight survey should be carried out on all passenger ships to verify any changes in lightship displacement and longitudinal centre of gravity. The ship should be re-inclined whenever, in comparison with the approved stability information, a deviation from the lightship displacement exceeding 2% or a deviation of the longitudinal centre of gravity exceeding 1% of L is found, or anticipated.

8.1.6 The inclining test prescribed is adaptable for ships with a length below 24 m if special precautions are taken to ensure the accuracy of the test procedure.

³⁴ Refer to regulation II-1/5 of the 1974 SOLAS Convention, as amended.

³⁵ For the purpose of paragraphs 8.1.2 and 8.1.5 the length (L) means the subdivision length (L_S) as defined in regulation II-1/2.1 of the 1974 SOLAS Convention, as amended. For ships to which the Convention applies, and for other ships the length (L) means the length of ship as defined in 2.12 of the Purpose and Definitions of this Code.

8.2 Preparations for the inclining test

8.2.1 *Notification of the Administration*

Written notification of the inclining test should be sent to the Administration as it requires or in due time before the test. An Administration representative should be present to witness the inclining test and the test results be submitted for review.

The responsibility for making preparations, conducting the inclining test and lightweight survey, recording the data, and calculating the results rests with the shipyard, owner or naval architect. While compliance with the procedures outlined herein will facilitate an expeditious and accurate inclining test, it is recognized that alternative procedures or – arrangements may be equally efficient. However, to minimize risk of delay, it is recommended that all such variances be submitted to the Administration for review prior to the inclining test.

8.2.1.1 *Details of notification*

Written notification should provide the following information as the Administration may require:

- .1 identification of the ship by name and shipyard hull number, if applicable;
- .2 date, time, and location of the test;
- .3 inclining weight data:
 - .1 type;
 - .2 amount (number of units and weight of each);
 - .3 certification;
 - .4 method of handling (i.e. sliding rail or crane);
 - .5 anticipated maximum angle of heel to each side;
- .4 measuring devices:
 - .1 pendulums – approximate location and length;
 - .2 U-tubes – approximate location and length;
 - .3 inclinometers – location and details of approvals and calibrations;
- .5 approximate trim;
- .6 condition of tanks;
- .7 estimated weights to deduct, to complete, and to relocate in order to place the ship in its true lightship condition;

- .8 detailed description of any computer software to be used to aid in calculations during the inclining test; and
- .9 name and telephone number of the person responsible for conducting the inclining test.

8.2.2 *General condition of the ship*

8.2.2.1 A ship should be as complete as possible at the time of the inclining test. The test should be scheduled to minimize the disruption in the ship's delivery date or its operational commitments.

8.2.2.2 The amount and type of work left to be completed (mass to be added) affect the accuracy of the lightship characteristics, so good judgement should be used. If the mass or centre of gravity of an item to be added cannot be determined with confidence, it is best to conduct the inclining test after the item is added.

8.2.2.3 Temporary material, tool boxes, staging, sand, debris, etc., on board should be reduced to absolute minimum before the inclining test. Excess crew or personnel not directly involved in the inclining test should be removed from on board the ship before the test.

8.2.2.4 Decks should be free of water. Water trapped on deck may shift and pocket in a fashion similar to liquids in a tank. Any rain, snow or ice accumulated on the ship should be removed prior to the test.

8.2.2.5 The anticipated liquid loading for the test should be included in the planning for the test. Preferably, all tanks should be empty and clean, or completely full. The number of slack tanks should be kept to an absolute minimum. The viscosity of the fluid, the depth of the fluid and the shape of the tank should be such that the free surface effect can be accurately determined.

8.2.2.6 The ship should be moored in a quiet, sheltered area free from extraneous forces such as propeller wash from passing vessels, or sudden discharges from shore side pumps. The tide conditions and the trim of the ship during the test should be considered. Prior to the test, the depth of water should be measured and recorded in as many locations as are necessary to ensure that the ship will not contact the bottom. The specific gravity of water should be accurately recorded. The ship should be moored in a manner to allow unrestricted heeling. The access ramps should be removed. Power lines, hoses, etc., connected to shore should be at a minimum, and kept slack at all times.

8.2.2.7 The ship should be as upright as possible; with inclining weights in the initial position, up to one-half degree of list is acceptable. The actual trim and deflection of keel, if practical, should be considered in the hydrostatic data. In order to avoid excessive errors caused by significant changes in the water plane area during heeling, hydrostatic data for the actual trim and the maximum anticipated heeling angles should be checked beforehand.

8.2.2.8 The total weight used should be sufficient to provide a minimum inclination of one degree and a maximum of four degrees of heel to each side. The Administration may, however, accept a smaller inclination angle for large ships provided that the requirements on pendulum deflection or U-tube difference in height in 8.2.2.9 are complied with. Test weights should be compact and of such a configuration that the vertical centre of gravity of the weights can be accurately determined. Each weight should be marked with an identification number and its mass. Re-certification of the test weights should be carried out prior to the incline. A crane of sufficient capacity and

reach, or some other means, should be available during the inclining test to shift weights on the decking in an expeditious and safe manner. Water ballast transfer may be carried out, when it is impractical to incline using solid weights if acceptable to the Administration.

8.2.2.9 The use of three pendulums is recommended but a minimum of two should be used to allow identification of bad readings at any one pendulum station. They should each be located in an area protected from the wind. One or more pendulums may be substituted by other measuring devices (U-tubes or inclinometers) at the discretion of the Administration. Alternative measuring devices should not be used to reduce the minimum inclining angles recommended in 8.2.2.8.

The use of an inclinometer or U-tube should be considered in each separate case. It is recommended that inclinometers or other measuring devices only be used in conjunction with at least one pendulum.

8.2.2.10 Efficient two-way communications should be provided between central control and the weight handlers and between central control and each pendulum station. One person at a central control station should have complete control over all personnel involved in the test.

8.3 Plans required

The person in charge of the inclining test should have available a copy of the following plans at the time of the inclining test:

- .1 lines plan;
- .2 hydrostatic curves or hydrostatic data;
- .3 general arrangement plan of decks, holds, inner bottoms, etc.;
- .4 capacity plan showing capacities and vertical and longitudinal centres of gravity of cargo spaces, tanks, etc. When ballast water is used as inclining weight, the transverse and vertical centres of gravity for the applicable tanks for each angle of inclination, must be available;
- .5 tank sounding tables;
- .6 draught mark locations; and
- .7 docking drawing with keel profile and draught mark corrections (if available).

8.4 Test procedure

8.4.1 Procedures followed in conducting the inclining test and lightweight survey should be in accordance with the recommendations laid out in annex 1 (Detailed guidance for the conduct of an inclining test) to this Code.

8.4.1.1 Freeboard/draught readings should be taken to establish the position of the waterline in order to determine the displacement of the ship at the time of the inclining test. It is recommended that at least five freeboard readings, approximately equally spaced, be taken on each side of the ship or that all draught marks (forward, midship and aft) be read on each side of the ship. Draught/freeboard readings should be read immediately before or immediately after the inclining test.

8.4.1.2 The standard test employs eight distinct weight movements. Movement No.8, a recheck of the zero point, may be omitted if a straight line plot is achieved after movement No.7. If a straight line plot is achieved after the initial zero and six weight movements, the inclining test is complete and the second check at zero may be omitted. If a straight line plot is not achieved, those weight movements that did not yield acceptable plotted points should be repeated or explained.

8.4.2 A copy of the inclining data should be forwarded to the Administration along with the calculated results of the inclining test in an acceptable report format, if required.

8.4.3 All calculations performed during the inclining test and in preparation of an inclining test report may be carried out by a suitable computer program. Output generated by such a program may be used for presentation of all or partial data and calculations included in the test report if it is clear, concise, well documented, and generally consistent in form and content with Administration requirements.

8.5 Inclining test for MODUs

8.5.1 An inclining test should be required for the first unit of a design, when as near to completion as possible, to determine accurately the lightship data (weight and position of centre of gravity).

8.5.2 For successive units which are identical by design, the lightship data of the first unit of the series may be accepted by the Administration in lieu of an inclining test, provided the difference in lightship displacement or position of centre of gravity due to weight changes for minor differences in machinery, outfitting or equipment, confirmed by the results of a deadweight survey, are less than 1% of the values of the lightship displacement and principal horizontal dimensions as determined for the first of the series. Extra care should be given to the detailed weight calculation and comparison with the original unit of a series of column-stabilized, semi-submersible types as these, even though identical by design, are recognized as being unlikely to attain an acceptable similarity of weight or centre of gravity to warrant a waiver of the inclining test.

8.5.3 The results of the inclining test, or deadweight survey and inclining experiment adjusted for weight differences, should be indicated in the Operating Manual.

8.5.4 A record of all changes to machinery, structure, outfit and equipment that affect the lightship data, should be maintained in the Operating Manual or a lightship data alterations log and be taken into account in daily operations.

8.5.5 For column-stabilized units, a deadweight survey should be conducted at intervals not exceeding five years. Where the deadweight survey indicates a change from the calculated lightship displacement in excess of 1% of the operating displacement, an inclining test should be conducted.

8.5.6 An inclining test or a deadweight survey should be carried out in the presence of an officer of the Administration, or a duly authorized person or representative of an approved organization.

8.6 Stability test for pontoons

An inclining experiment is not normally required for a pontoon, provided a conservative value of the lightship vertical centre of gravity (KG) is assumed for the stability calculations. The KG can be assumed at the level of the main deck although it is recognized that a lesser value could be acceptable if fully documented. The lightship displacement and longitudinal centre of gravity should be determined by calculation based on draught and density readings.

ANNEX 1

DETAILED GUIDANCE FOR THE CONDUCT OF AN INCLINING TEST

1 INTRODUCTION

This annex supplements the inclining standards put forth in part B, chapter 8 (Determination of lightship parameters) of this Code. This annex contains important detailed procedures for conducting an inclining test in order to ensure that valid results are obtained with maximum precision at a minimal cost to owners, shipyards and the Administration. A complete understanding of the correct procedures used to perform an inclining test is imperative in order to ensure that the test is conducted properly and so that results can be examined for accuracy as the inclining experiment is conducted.

2 PREPARATIONS FOR THE INCLINING TEST

2.1 Free surface and tankage

2.1.1 If there are liquids on board the ship when it is inclined, whether in the bilges or in the tanks, they will shift to the low side when the ship heels. This shift of liquids will exaggerate the heel of the ship. Unless the exact weight and distance of liquid shifted can be precisely calculated, the metacentric height (GM) calculated from the inclining test will be in error. Free surface should be minimized by emptying the tanks completely and making sure all bilges are dry; or by completely filling the tanks so that no shift of liquid is possible. The latter method is not the optimum because air pockets are difficult to remove from between structural members of a tank, and the weight and centre of the liquid in a full tank should be accurately determined in order to adjust the lightship values accordingly. When tanks must be left slack, it is desirable that the sides of the tanks be parallel vertical planes and the tanks be regular in shape (i.e. rectangular, trapezoidal, etc.) when viewed from above, so that the free surface moment of the liquid can be accurately determined. For example, the free surface moment of the liquid in a tank with parallel vertical sides can be readily calculated by the formula:

$$M_{fs} = l * b^3 * \rho_t / 12 \quad (\text{mt})$$

where:

l = length of tank (m)

b = breadth of tank (m)

ρ_t = specific gravity of liquid in tank (t/m³)

$$\text{Free surface correction} = \frac{\sum M_{fs}(1) + M_{fs}(2) + \dots + M_{fs}(x)}{\Delta} \quad (\text{m})$$

where:

M_{fs} = free surface moment (mt)

Δ = displacement (t)

Free surface correction is independent of the height of the tank in the ship, location of the tank, and direction of heel. As the width of the tank increases, the value of free surface moment increases by the third power. The distance available for the liquid to shift is the predominant factor. This is why even the smallest amount of liquid in the bottom of a wide tank or bilge is normally unacceptable and should be removed prior to the inclining experiment. Insignificant amounts of liquids in V-shaped tanks or voids (e.g., a chain locker in the bow), where the potential shift is negligible, may remain if removal of the liquid would be difficult or would cause extensive delays.

When ballast water is used as inclining weight, the actual transverse and vertical movements of the liquid should be calculated taking into account the change of heel of the ship. Free surface corrections as defined in this paragraph should not apply to the inclining tanks.

2.1.2 **Free surface and slack tanks:** The number of slack tanks should normally be limited to one port/starboard pair or one centreline tank of the following:

- .1 fresh water reserve feed tanks;
- .2 fuel/diesel oil storage tanks;
- .3 fuel/diesel oil day tanks;
- .4 lube oil tanks;
- .5 sanitary tanks; or
- .6 potable water tanks.

To avoid pocketing, slack tanks should normally be of regular (i.e. rectangular, trapezoidal, etc.) cross section and be 20% to 80% full if they are deep tanks and 40% to 60% full if they are double-bottom tanks. These levels ensure that the rate of shifting of liquid remains constant throughout the heel angles of the inclining test. If the trim changes as the ship is inclined, then consideration should also be given to longitudinal pocketing. Slack tanks containing liquids of sufficient viscosity to prevent free movement of the liquids, as the ship is inclined (such as bunker at low temperature), should be avoided since the free surface cannot be calculated accurately. A free surface correction for such tanks should not be used unless the tanks are heated to reduce viscosity. Communication between tanks should never be allowed. Cross-connections, including those via manifolds, should be closed. Equal liquid levels in slack tank pairs can be a warning sign of open cross connections. A bilge, ballast, and fuel oil piping plan can be referred to, when checking for cross connection closures.

2.1.3 **Pressed-up tanks:** “Pressed up” means completely full with no voids caused by trim or inadequate venting. Anything less than 100% full, for example the 98% condition regarded as full for operational purposes, is not acceptable. Preferably, the ship should be rolled from side to side to eliminate entrapped air before taking the final sounding. Special care should be taken when pressing fuel oil tanks to prevent accidental pollution. An example of a tank that would appear “pressed up”, but actually contains entrapped air, is shown in figure A1-2.1.3.

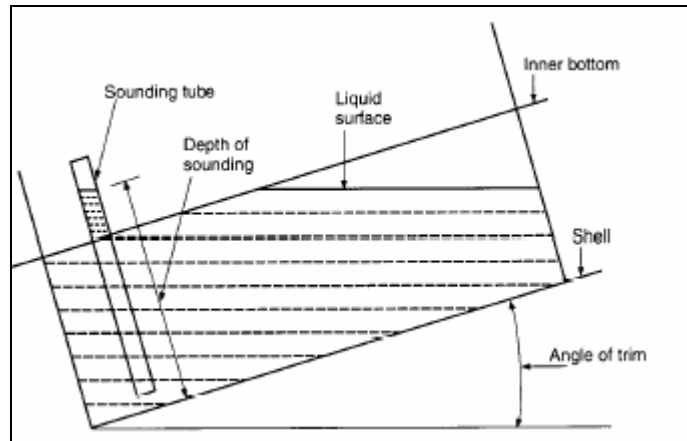

Figure A1-2.1.3

2.1.4 **Empty tanks:** It is generally not sufficient to simply pump tanks until suction is lost. Enter the tank after pumping to determine if final stripping with portable pumps or by hand is necessary. The exceptions are very narrow tanks or tanks where there is a sharp deadrise, since free surface would be negligible. Since all empty tanks should be inspected, all manholes should be open and the tanks well ventilated and certified as safe for entry. A safe testing device should be on hand to test for sufficient oxygen and minimum toxic levels. A certified marine chemist's certificate certifying that all fuel oil and chemical tanks are safe for human entry should be available, if necessary.

2.2 Mooring arrangements

The importance of good mooring arrangements cannot be overemphasized. The arrangement selections will be dependent upon many factors. Among the most important are depth of water, wind and current effects. Whenever possible, the ship should be moored in a quiet, sheltered area free from extraneous forces such as propeller wash from passing ships, or sudden discharges from shore side pumps. The depth of water under the hull should be sufficient to ensure that the hull will be entirely free of the bottom. The tide conditions and the trim of the ship during the test should be considered. Prior to the test, the depth of water should be measured and recorded in as many locations as necessary to ensure the ship will not contact the bottom. If marginal, the test should be conducted during high tide or the ship moved to deeper water.

2.2.1 The mooring arrangement should ensure that the ship will be free to list without restraint for a sufficient period of time to allow a satisfactory reading of the heeling angle, due to each weight shift, to be recorded.

2.2.2 The ship should be held by lines at the bow and the stern, attached to bollards and/or cleats on the deck. If suitable restraint of the ship cannot be achieved using deck fittings, then temporary padeyes should be attached as close as possible to the centreline of the ship and as near the waterline as practical. Where the ship can be moored to one side only, it is good practice to supplement the bow and stern lines with two spring lines in order to maintain positive control of the ship, as shown in figure A1-2.2.2. The leads of the spring lines should be as long as practicable. Cylindrical camels should be provided between the ship and the dock. All lines should be slack, with the ship free of the pier and camels, when taking readings.

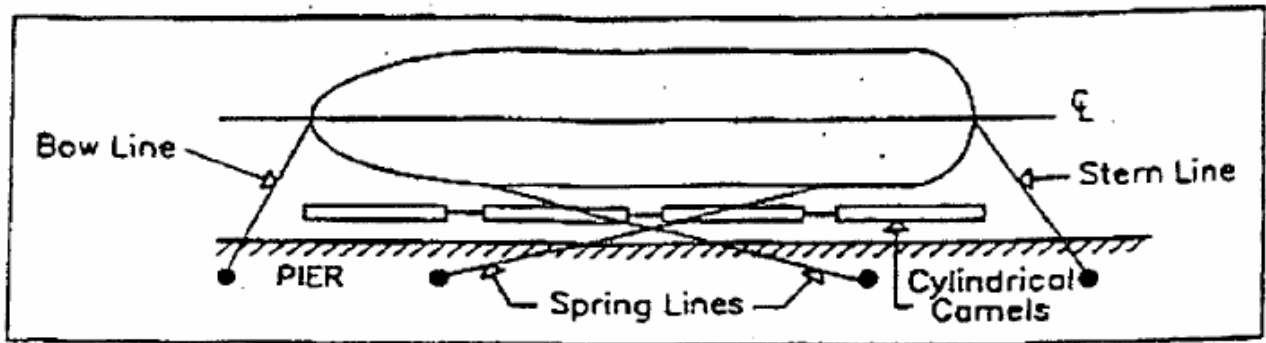

Figure A1-2.2.2

2.2.2.1 If the ship is held off the pier by the combined effect of the wind and current, a superimposed heeling moment will act on the ship throughout the test. For steady conditions this will not affect the results. Gusty winds or uniformly varying wind and/or current will cause these superimposed heeling moments to change, which may require additional test points to obtain a valid test. The need for additional test points can be determined by plotting test points as they are obtained.

2.2.2.2 If the ship is pressed against the fenders by wind and/or current, all lines should be slack. The cylindrical camels will prevent binding but there will be an additional superimposed heeling moment due to the ship bearing against the camels. This condition should be avoided where possible but, when used, consideration should be given to pulling the ship free of the dock and camels and letting the ship drift as readings are taken.

2.2.2.3 Another acceptable arrangement is where the combined wind and current are such that the ship may be controlled by only one line at either the bow or the stern. In this case, the control line should be led from on or near the centreline of the ship with all lines but the control line slack, the ship is free to veer with the wind and/or current as readings are taken. This can sometimes be troublesome because varying wind and/or current can cause distortion of the plot.

2.2.3 The mooring arrangement should be submitted to the approval authority for review prior to the test.

2.2.4 If a floating crane is used for handling inclining weights, it should not be moored to the ship.

2.3 Test weights

2.3.1 Weights, such as porous concrete, that can absorb significant amounts of moisture should only be used if they are weighed just prior to the inclining test or if recent weight certificates are presented. Each weight should be marked with an identification number and its weight. For small ships, drums completely filled with water may be used. Drums should normally be full and capped to allow accurate weight control. In such cases, the weight of the drums should be verified in the presence of the Administration representative using a recently calibrated scale.

2.3.2 Precautions should be taken to ensure that the decks are not overloaded during weight movements. If deck strength is questionable then a structural analysis should be performed to determine if existing framing can support the weight.

2.3.3 Generally, the test weights should be positioned as far outboard as possible on the upper deck. The test weights should be on board and in place prior to the scheduled time of the inclining test.

2.3.4 Where the use of solid weights to produce the inclining moment is demonstrated to be impracticable, the movement of ballast water may be permitted as an alternative method. This acceptance would be granted for a specific test only, and approval of the test procedure by the Administration is required. As a minimal prerequisite for acceptability, the following conditions should be required:

- .1 inclining tanks should be wall-sided and free of large stringers or other internal members that create air pockets. Other tank geometries may be accepted at the discretion of the Administration;
- .2 tanks should be directly opposite to maintain ship's trim;
- .3 specific gravity of ballast water should be measured and recorded;
- .4 pipelines to inclining tanks should be full. If the ship's piping layout is unsuitable for internal transfer, portable pumps and pipes/hoses may be used;
- .5 blanks must be inserted in transfer manifolds to prevent the possibility of liquids being "leaked" during transfer. Continuous valve control must be maintained during the test;
- .6 all inclining tanks must be manually sounded before and after each shift;
- .7 vertical, longitudinal and transverse centres should be calculated for each movement;
- .8 accurate sounding/ullage tables must be provided. The ship's initial heel angle should be established prior to the incline in order to produce accurate values for volumes and transverse and vertical centres of gravity for the inclining tanks at every angle of heel. The draught marks amidships (port and starboard) should be used when establishing the initial heel angle;
- .9 verification of the quantity shifted may be achieved by a flow meter or similar device; and
- .10 the time to conduct the inclining must be evaluated. If time requirements for transfer of liquids are considered too long, water may be unacceptable because of the possibility of wind shifts over long periods of time.

2.4 Pendulums

2.4.1 The pendulums should be long enough to give a measured deflection, to each side of upright, of at least 15 cm. Generally, this will require a pendulum length of at least 3 m. It is recommended that pendulum lengths of 4 to 6 m be used. Usually, the longer the pendulum the greater the accuracy of the test; however, if excessively long pendulums are used on a tender ship the pendulums may not settle down and the accuracy of the pendulums would then be questionable. On large ships with high GM, pendulum lengths in excess of the length recommended above may be required to obtain the minimum deflection. In such cases, the trough, as shown in figure A1-2.4.6, should be filled with high-viscosity oil. If the pendulums are of different lengths, the possibility of collusion between station recorders is avoided.

2.4.2 On smaller ships, where there is insufficient headroom to hang long pendulums, the 15 cm deflection should be obtained by increasing the test weight so as to increase the heel. On most ships the typical inclination is between one and four degrees.

2.4.3 The pendulum wire should be piano wire or other monofilament material. The top connection of the pendulum should afford unrestricted rotation of the pivot point. An example is that of a washer with the pendulum wire attached suspended from a nail.

2.4.4 A trough filled with a liquid should be provided to dampen oscillations of the pendulum after each weight movement. It should be deep enough to prevent the pendulum weight from touching the bottom. The use of a winged plumb bob at the end of the pendulum wire can also help to dampen the pendulum oscillations in the liquid.

2.4.5 The battens should be smooth, light-coloured wood, 1 to 2 cm thick, and should be securely fixed in position so that an inadvertent contact will not cause them to shift. The batten should be aligned close to the pendulum wire but not in contact with it.

2.4.6 A typical satisfactory arrangement is shown in figure A1-2.4.6. The pendulums may be placed in any location on the ship, longitudinally and transversely. The pendulums should be in place prior to the scheduled time of the inclining test.

2.4.7 It is recommended that inclinometers or other measuring devices only be used in conjunction with at least one pendulum. The Administration may approve an alternative arrangement when this is found impractical.

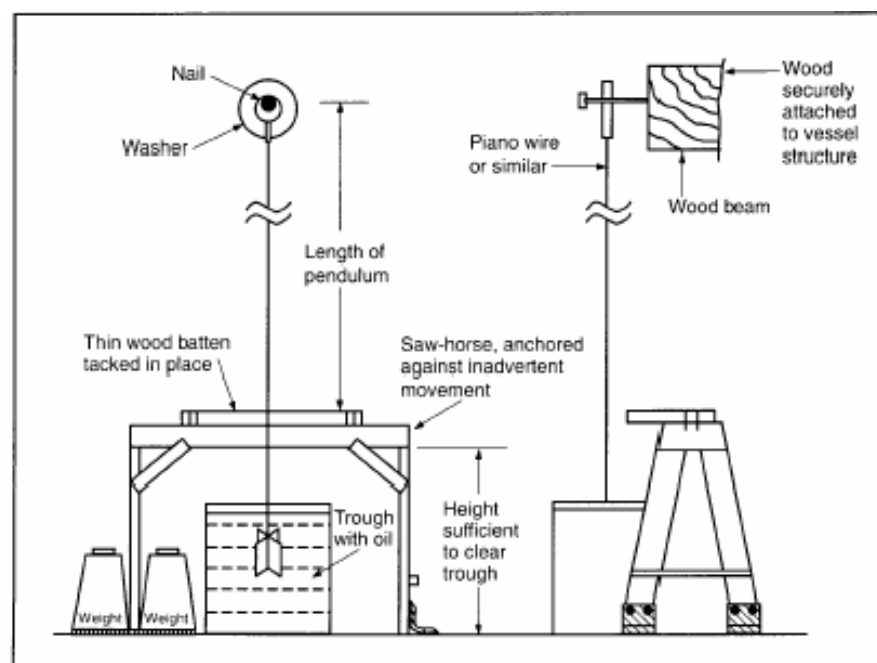

Figure A1-2.4.6

2.5 U-tubes

2.5.1 The legs of the device should be securely positioned as far as outboard as possible and should be parallel to the centreline plane of the ship. The distance between the legs should be measured perpendicular to the centreline plane. The legs should be vertical, as far as practical.

2.5.2 Arrangements should be made for recording all readings at both legs. For easy reading and checking for air pockets, clear plastic tube or hose should be used throughout. The U-tube should be pressure-tested prior to the inclining test to ensure watertightness.

2.5.3 The horizontal distance between the legs of the U-tube should be sufficient to obtain a level difference of at least 15 cm between the upright and the maximum inclination to each side.

2.5.4 Normally, water would be used as the liquid in the U-tube. Other low-viscosity liquids may also be considered.

2.5.5 The tube should be free of air pockets. Arrangements should be made to ensure that the free flow of the liquid in the tube is not obstructed.

2.5.6 Where a U-tube is used as a measuring device, due consideration should be given to the prevailing weather conditions (see 4.1.1.3):

- .1 if the U-tube is exposed to direct sunlight, arrangements should be made to avoid temperature differences along the length of the tube;
- .2 if temperatures below 0°C are expected, the liquid should be a mixture of water and an anti-freeze additive; and
- .3 where heavy rain squalls can be expected, arrangements should be made to avoid additional water entering the U-tube.

2.6 Inclinometers

The use of inclinometers should be subject to at least the following recommendations:

- .1 the accuracy should be equivalent to that of the pendulum;
- .2 the sensitivity of the inclinometer should be such that the non-steady heeling angle of the ship can be recorded throughout the measurement;
- .3 the recording period should be sufficient to accurately measure the inclination. The recording capacity should be generally sufficient for the whole test;
- .4 the instrument should be able to plot or print the recorded inclination angles on paper;
- .5 the instrument should have linear performance over the expected range of inclination angles;
- .6 the instrument should be supplied with the manufacturer's instructions giving details of calibration, operating instructions, etc.; and
- .7 it should be possible to demonstrate the required performance to the satisfaction of the Administration during the inclining test.

3 EQUIPMENT REQUIRED

Besides the physical equipment necessary such as the inclining weights, pendulums, small boat, etc., the following are necessary and should be provided by or made available to the person in charge of the inclining:

- .1 engineering scales for measuring pendulum deflections (rules should be subdivided sufficiently to achieve the desired accuracy);
- .2 sharp pencils for marking pendulum deflections;
- .3 chalk for marking the various positions of the inclining weights;
- .4 a sufficiently long measuring tape for measuring the movement of the weights and locating different items on board;
- .5 a sufficiently long sounding tape for sounding tanks and taking freeboard readings;
- .6 one or more well maintained specific gravity hydrometers with range sufficient to cover 0.999 to 1.030, to measure the specific gravity of the water in which the ship is floating (a hydrometer for measuring specific gravity of less than 1.000 may be needed in some locations);
- .7 other hydrometers as necessary to measure the specific gravity of any liquids on board;
- .8 graph paper to plot inclining moments versus tangents;
- .9 a straight edge to draw the measured waterline on the lines drawing;
- .10 a pad of paper to record data;
- .11 an explosion-proof testing device to check for sufficient oxygen and absence of lethal gases in tanks and other closed spaces such as voids and cofferdams;
- .12 a thermometer; and
- .13 draught tubes (if necessary).

4 TEST PROCEDURE

The inclining experiment, the freeboard/draught readings and the survey may be conducted in any order and still achieve the same results. If the person conducting the inclining test is confident that the survey will show that the ship is in an acceptable condition and there is the possibility of the weather becoming unfavourable, then it is suggested that the inclining be performed first and the survey last. If the person conducting the test is doubtful that the ship is complete enough for the test, it is recommended that the survey be performed first since this could invalidate the entire test, regardless of the weather conditions. It is very important that all weights, the number of people on board, etc., remain constant throughout the test.

4.1 Initial walk through and survey

The person responsible for conducting the inclining test should arrive on board the ship well in advance of the scheduled time of the test to ensure that the ship is properly prepared for the test. If the ship to be inclined is large, a preliminary walk through may need to be done the day preceding the actual incline. To ensure the safety of personnel conducting the walk through, and to improve the documentation of surveyed weights and deficiencies, at least two persons should make the initial walk through. Things to check include: all compartments are open, clean, and dry, tanks are well ventilated and gas-free, movable or suspended items are secured and their position documented, pendulums are in place, weights are on board and in place, a crane or other method for moving weights is available, and the necessary plans and equipment are available. Before beginning the inclining test, the person conducting the test should:

- .1 consider the weather conditions. The combined adverse effect of wind, current and sea may result in difficulties or even an invalid test due to the following:
 - .1 inability to accurately record freeboards and draughts;
 - .2 excessive or irregular oscillations of the pendulums;
 - .3 variations in unavoidable superimposed heeling moments.

In some instances, unless conditions can be sufficiently improved by moving the ship to a better location, it may be necessary to delay or postpone the test. Any significant quantities of rain, snow, or ice should be removed from the ship before the test. If bad weather conditions are detected early enough and the weather forecast does not call for improving conditions, the Administration representative should be advised prior to departure from the office and an alternative date scheduled;

- .2 make a quick overall survey of the ship to make sure the ship is complete enough to conduct the test and to ensure that all equipment is in place. An estimate of items which will be outstanding at the time of the inclining test should be included as part of any test procedure submitted to the Administration. This is required so that the Administration representative can advise the shipyard/naval architect if in their opinion the ship will not be sufficiently complete to conduct the incline and that it should be rescheduled. If the condition of the ship is not accurately depicted in the test procedure and at the time of the inclining test the Administration representative considers that the ship is in such condition that an accurate incline cannot be conducted, the representative may refuse to accept the incline and require that the incline be conducted at a later date;
- .3 enter all empty tanks after it is determined that they are well ventilated and gas-free to ensure that they are dry and free of debris. Ensure that any pressed-up tanks are indeed full and free of air pockets. The anticipated liquid loading for the incline should be included in the procedure required to be submitted to the Administration;
- .4 survey the entire ship to identify all items which need to be added to the ship, removed from the ship, or relocated on the ship to bring the ship to the lightship condition. Each item should be clearly identified by weight and vertical and longitudinal location. If necessary, the transverse location should also be

recorded. The inclining weights, the pendulums, any temporary equipment and dunnage, and the people on board during the inclining test are all among the weights to be removed to obtain the lightship condition. The person calculating the lightship characteristics from the data gathered during the incline and survey and/or the person reviewing the inclining test may not have been present during the test and should be able to determine the exact location of the items from the data recorded and the ship's drawings. Any tanks containing liquids should be accurately sounded and the soundings recorded;

- .5 it is recognized that the weight of some items on board, or that are to be added, may have to be estimated. If this is necessary, it is in the best interest of safety to be on the safe side when estimating, so the following rules of thumb should be followed:
 - .1 when estimating weights to be added:
 - .1.1 estimate high for items to be added high in the ship; and
 - .1.2 estimate low for items to be added low in the ship;
 - .2 when estimating weights to be removed:
 - .2.1 estimate low for items to be removed from high in the ship; and
 - .2.2 estimate high for items to be removed from low in the ship;
 - .3 when estimating weights to be relocated:
 - .3.1 estimate high for items to be relocated to a higher point in the ship; and
 - .3.2 estimate low for items to be relocated to a lower point in the ship.

4.2 Freeboard/draught readings

4.2.1 Freeboard/draught readings should be taken to establish the position of the waterline in order to determine the displacement of the ship at the time of the inclining test. It is recommended that at least five freeboard readings, approximately equally spaced, be taken on each side of the ship or that all draught marks (forward, midship, and aft) be read on each side of the ship. Draught mark readings should be taken to assist in determining the waterline defined by freeboard readings, or to verify the vertical location of draught marks on ships where their location has not been confirmed. The locations for each freeboard reading should be clearly marked. The longitudinal location along the ship should be accurately determined and recorded since the (moulded) depth at each point will be obtained from the ship's lines. All freeboard measurements should include a reference note clarifying the inclusion of the coaming in the measurement and the coaming height.

4.2.2 Draught and freeboard readings should be read immediately before or immediately after the inclining test. Weights should be on board and in place and all personnel who will be on board during the test, including those who will be stationed to read the pendulums, should be on board and in location during these readings. This is particularly important on small ships. If readings

are made after the test, the ship should be maintained in the same condition as during the test. For small ships, it may be necessary to counterbalance the list and trim effects of the freeboard measuring party. When possible, readings should be taken from a small boat.

4.2.3 A small boat should be available to aid in the taking of freeboard and draught mark readings. It should have low freeboard to permit accurate observation of the readings.

4.2.4 The specific gravity of the flotation water should be determined at this time. Samples should be taken from a sufficient depth of the water to ensure a true representation of the flotation water and not merely surface water, which could contain fresh water from run-off of rain. A hydrometer should be placed in a water sample and the specific gravity read and recorded. For large ships, it is recommended that samples of the flotation water be taken forward, midship, and aft and the readings averaged. For small ships, one sample taken from midships should be sufficient. The temperature of the water should be taken and the measured specific gravity corrected for deviation from the standard, if necessary. A correction to water specific gravity is not necessary if the specific gravity is determined at the inclining experiment site. Correction is necessary if specific gravity is measured when sample temperature differs from the temperature at the time of the inclining (e.g., if check of specific gravity is done at the office).

4.2.5 A draught mark reading may be substituted for a given freeboard reading at that longitudinal location if the height and location of the mark have been verified to be accurate by a keel survey while the ship was in dry dock.

4.2.6 A device, such as a draught tube, can be used to improve the accuracy of freeboard/draught readings by damping out wave action.

4.2.7 The dimensions given on a ship's lines drawing are normally moulded dimensions. In the case of depth, this means the distance from the inside of the bottom shell to the inside of the deck plate. In order to plot the ship's waterline on the lines drawing, the freeboard readings should be converted to moulded draughts. Similarly, the draught mark readings should be corrected from extreme (bottom of keel) to moulded (top of keel) before plotting. Any discrepancy between the freeboard/draught readings should be resolved.

4.2.8 The mean draught (average of port and starboard readings) should be calculated for each of the locations where freeboard/draught readings are taken and plotted on the ship's lines drawing or outboard profile to ensure that all readings are consistent and together define the correct waterline. The resulting plot should yield either a straight line or a waterline which is either hogged or sagged. If inconsistent readings are obtained, the freeboards/draughts should be retaken.

4.3 The incline

4.3.1 Prior to any weight movements the following should be checked:

- .1 the mooring arrangement should be checked to ensure that the ship is floating freely (this should be done just prior to each reading of the pendulums);
- .2 the pendulums should be measured and their lengths recorded. The pendulums should be aligned so that when the ship heels, the wire will be close enough to the batten to ensure an accurate reading but will not come into contact with the batten. The typical satisfactory arrangement is shown in figure A1-2.4.6;

- .3 the initial position of the weights is marked on the deck. This can be done by tracing the outline of the weights on the deck;
- .4 the communications arrangement is adequate; and
- .5 all personnel are in place.

4.3.2 A plot should be run during the test to ensure that acceptable data are being obtained. Typically, the abscissa of the plot will be heeling moment $W(x)$ (weight times distance x) and the ordinate will be the tangent of the heel angle (deflection of the pendulum divided by the length of the pendulum). This plotted line does not necessarily pass through the origin or any other particular point for no single point is more significant than any other point. A linear regression analysis is often used to fit the straight line. The weight movements shown in figure A2-4.3.2-1 give a good spread of points on the test plot.

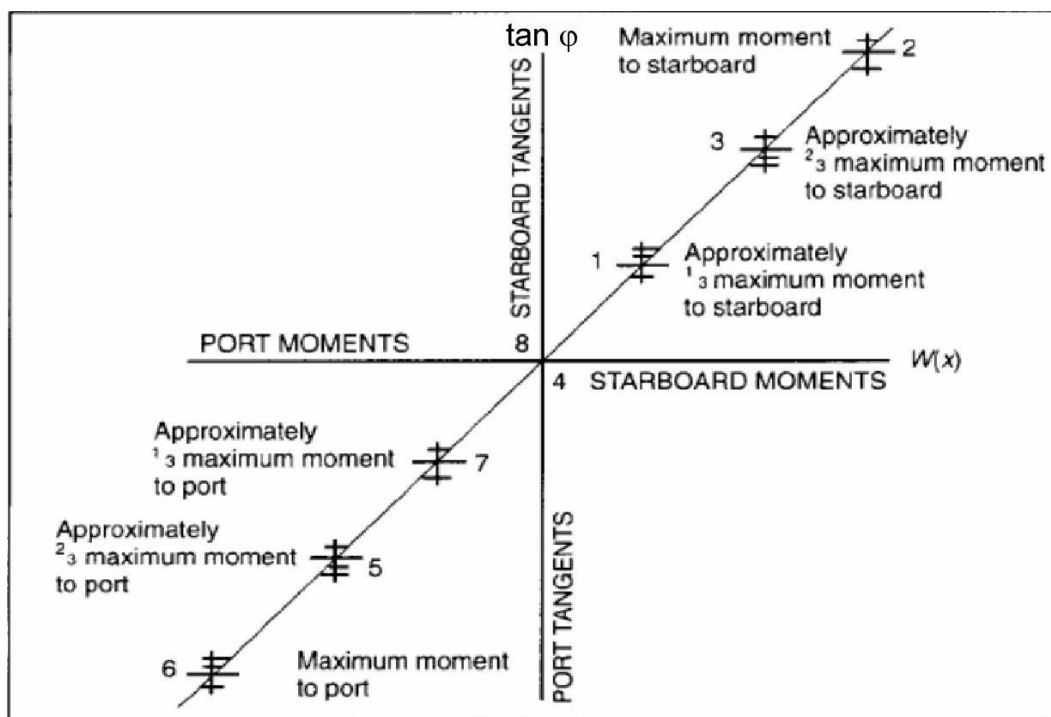

Figure A1-4.3.2-1

The plotting of all the readings for each of the pendulums during the inclining experiment aids in the discovery of bad readings. Since $W(x)/\tan \phi$ should be constant, the plotted line should be straight. Deviations from a straight line are an indication that there were other moments acting on the ship during the inclining. These other moments should be identified, the cause corrected, and the weight movements repeated until a straight line is achieved. Figures A1-4.3.2-2 to A1-4.3.2-5 illustrate examples of how to detect some of these other moments during the inclining, and a recommended solution for each case. For simplicity, only the average of the readings is shown on the inclining plots.

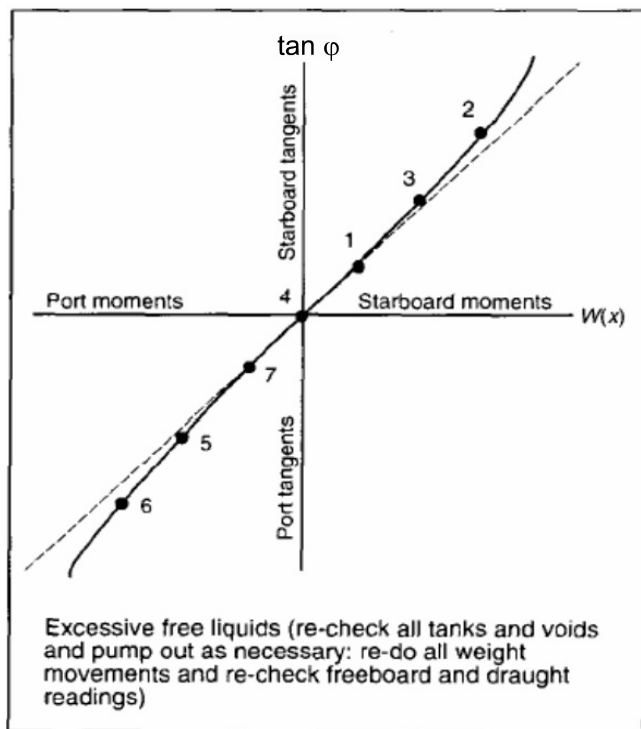

Figure A1-4.3.2-2

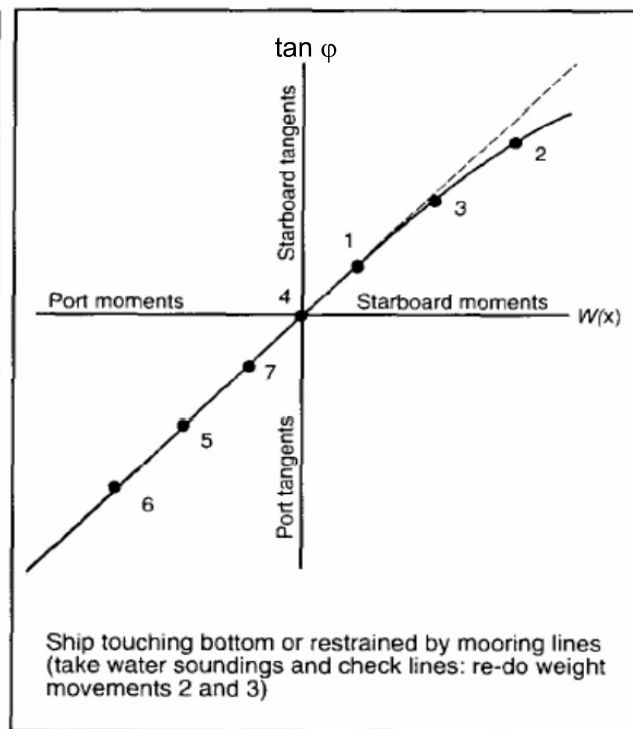

Figure A1-4.3.2-3

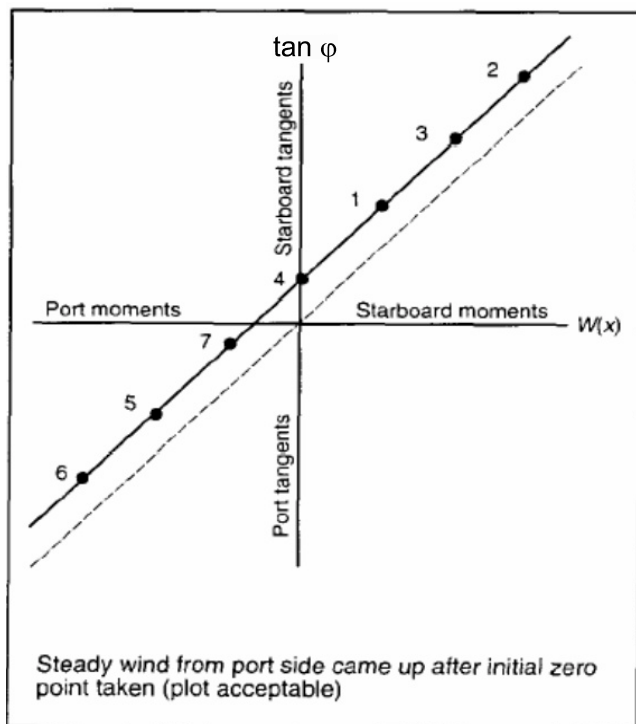

Figure A1-4.3.2-4

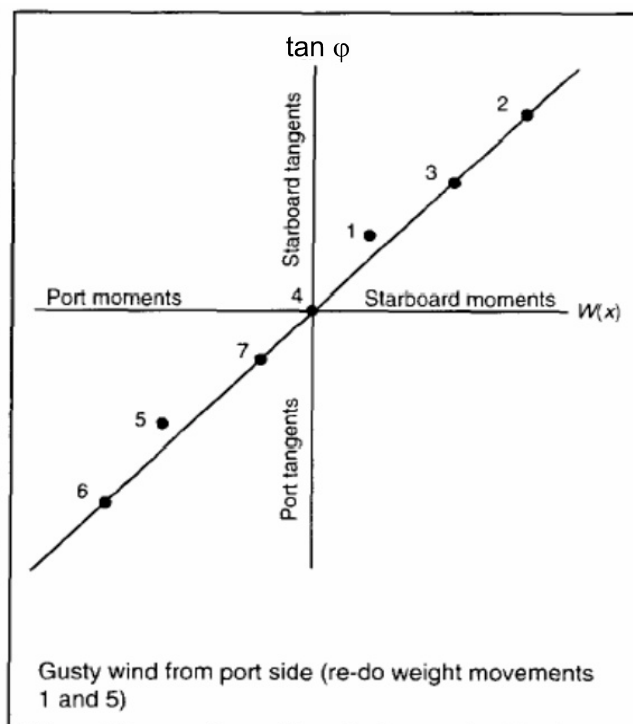

Figure A1-4.3.2-5

4.3.3 Once everything and everyone is in place, the zero position should be obtained and the remainder of the experiment conducted as quickly as possible, while maintaining accuracy and proper procedures, in order to minimize the possibility of a change in environmental conditions during the test.

4.3.4 Prior to each pendulum reading, each pendulum station should report to the control station when the pendulum has stopped swinging. Then, the control station will give a “standby” warning and then a “mark” command. When “mark” is given, the batten at each position should be marked at the location of the pendulum wire. If the wire was oscillating slightly, the centre of the oscillations should be taken as the mark. If any of the pendulum readers does not think the reading was a good one, the reader should advise the control station and the point should be retaken for all pendulum stations. Likewise, if the control station suspects the accuracy of a reading, it should be repeated for all the pendulum stations. Next to the mark on the batten should be written the number of the weight movement, such as zero for the initial position and one to seven for the weight movements.

4.3.5 Each weight movement should be made in the same direction, normally transversely, so as not to change the trim of the ship. After each weight movement, the distance the weight was moved (centre to centre) should be measured and the heeling moment calculated by multiplying the distance by the amount of weight moved. The tangent is calculated for each pendulum by dividing the deflection by the length of the pendulum. The resultant tangents are plotted on the graph. Provided there is good agreement among the pendulums with regard to the $\tan \phi$ value, the average of the pendulum readings may be graphed instead of plotting each of the readings.

4.3.6 Inclining data sheets should be used so that no data are forgotten and so that the data are clear, concise, and consistent in form and format. Prior to departing the ship, the person conducting the test and the Administration representative should initial each data sheet as an indication of their concurrence with the recorded data.

ANNEX 2

RECOMMENDATIONS FOR SKIPPERS OF FISHING VESSELS ON ENSURING A VESSEL'S ENDURANCE IN CONDITIONS OF ICE FORMATION

1 Prior to departure

1.1 Firstly, the skipper should, as in the case of any voyages in any season, ensure that the vessel is generally in a seaworthy condition, giving full attention to basic requirements such as:

- .1 loading of the vessel within the limits prescribed for the season (paragraph 1.2.1 below);
- .2 weathertightness and reliability of the devices for closing cargo and access hatches, outer doors and all other openings in the decks and superstructures of the vessel and the watertightness of the sidescuttles and of ports or similar openings in the sides below the freeboard deck to be checked;
- .3 condition of the freeing ports and scuppers as well as operational reliability of their closures to be checked;
- .4 emergency and life-saving appliances and their operational reliability;
- .5 operational reliability of all external and internal communication equipment; and
- .6 condition and operational reliability of the bilge and ballast pumping systems.

1.2 Further, with special regard to possible ice accretion, the skipper should:

- .1 consider the most critical loading condition against approved stability documents with due regard to fuel and water consumption, distribution of supplies, cargoes and fishing gear and with allowance for possible ice accretion;
- .2 be aware of the danger in having supplies and fishing gear stored on open weather deck spaces due to their large ice accretion surface and high centre of gravity;
- .3 ensure that a complete set of warm clothing for all members of the crew is available on the vessel as well as a complete set of hand tools and other appliances for combating ice accretion, a typical list thereof for small vessels is shown in section 4 of this annex;
- .4 ensure that the crew is acquainted with the location of means for combating ice accretion, as well as the use of such means, and that drills are carried out so that members of the crew know their respective duties and have the necessary practical skills to ensure the vessel's endurance under conditions of ice accretion;
- .5 acquaint himself with the meteorological conditions in the region of fishing grounds and en route to the place of destination; study the synoptical maps of this region and weather forecasts; be aware of warm currents in the vicinity of the fishing grounds, of the nearest coastline relief, of the existence of protected bays and of the location of ice fields and their boundaries; and

- .6 acquaint himself with the timetable of the radio stations transmitting weather forecasts and warnings of the possibility of ice accretion in the area of the relevant fishing grounds.

2 At sea

2.1 During the voyage and when the vessel is on the fishing grounds, the skipper should keep himself informed on all long-term and short-term weather forecasts and should arrange for the following systematic meteorological observations to be systematically recorded:

- .1 temperatures of the air and of the sea surface;
- .2 wind direction and force;
- .3 direction and height of waves and sea state;
- .4 atmospheric pressure, air humidity; and
- .5 frequency of splashing per minute and the intensity of ice accumulation on different parts of the vessel per hour.

2.2 All observed data should be recorded in the vessel's log-book. The skipper should compare the weather forecasts and icing charts with actual meteorological conditions, and should estimate the probability of ice formation and its intensity.

2.3 When the danger of ice formation arises, the following measures should be taken without delay:

- .1 all the means of combating ice formation should be ready for use;
- .2 all the fishing operations should be stopped, the fishing gear should be taken on board and placed in the under-deck spaces. If this cannot be done all the gear should be fastened for storm conditions on its prescribed place. It is particularly dangerous to leave the fishing gear suspended since its surface for ice formation is large and the point of suspension is generally located high;
- .3 barrels and containers with fish, packing, all gear and supplies located on deck as well as portable mechanisms should be placed in closed spaces as low as possible and firmly lashed;
- .4 all cargoes in holds and other compartments should be placed as low as possible and firmly lashed;
- .5 the cargo booms should be lowered and fastened;
- .6 deck machinery, hawser reels and boats should be covered with duck covers;
- .7 lifelines should be fastened on deck;
- .8 freeing ports fitted with covers should be brought into operative condition, all objects located near scuppers and freeing ports and preventing water drainage from deck should be taken away;

- .9 all cargo and companion hatches, manhole covers, weathertight outside doors in superstructures and deck-houses and portholes should be securely closed in order to ensure complete weathertightness of the vessel, access to the weather deck from inner compartments should be allowed only through the superstructure deck;
- .10 a check should be carried out as to whether the amount of water ballast on board and its location is in accordance with that recommended in “Stability guidance to skippers”; if there is sufficient freeboard, all the empty bottom tanks fitted with ballast piping should be filled with seawater;
- .11 all fire-fighting, emergency and life-saving equipment should be ready for use;
- .12 all drainage systems should be checked for their effectiveness;
- .13 deck lighting and searchlights should be checked;
- .14 a check should be carried out to make sure that each member of the crew has warm clothing; and
- .15 reliable two-way radio communication with both shore stations and other vessels should be established; radio calls should be arranged for set times.

2.4 The skipper should seek to take the vessel away from the dangerous area, keeping in mind that the lee edges of icefields, areas of warm currents and protected coastal areas are a good refuge for the vessel during weather when ice formation occurs.

2.5 Small fishing vessels on fishing grounds should keep nearer to each other and to larger vessels.

2.6 It should be remembered that the entry of the vessel into an icefield presents certain danger to the hull, especially when there is a high sea swell. Therefore the vessel should enter the icefield at a right angle to the icefield edge at low speed without inertia. It is less dangerous to enter an icefield bow to the wind. If a vessel must enter an icefield with the wind on the stern, the fact that the edge of the ice is more dense on the windward side should be taken into consideration. It is important to enter the icefield at the point where the ice floes are the smallest.

3 During ice formation

3.1 If in spite of all measures taken the vessel is unable to leave the dangerous area, all means available for removal of ice should be used as long as it is subjected to ice formation.

3.2 Depending on the type of vessel, all or many of the following ways of combating ice formation may be used:

- .1 removal of ice by means of cold water under pressure;
- .2 removal of ice with hot water and steam; and
- .3 breaking up of ice with ice crows, axes, picks, scrapers, or wooden sledge-hammers and clearing it with shovels.

3.3 When ice formation begins, the skipper should take into account the recommendations listed below and ensure their strict fulfilment:

- .1 report immediately ice formation to the shipowner and establish with him constant radio communication;
- .2 establish radio communication with the nearest vessels and ensure that it is maintained;
- .3 do not allow ice formation to accumulate on the vessel, immediately take steps to remove from the vessel's structures even the thinnest layer of ice and ice sludge from the upper deck;
- .4 check constantly the vessel's stability by measuring the roll period of the vessel during ice formation. If the rolling period increases noticeably, immediately take all possible measures in order to increase the vessel's stability;
- .5 ensure that each member of the crew working on the weather deck is warmly dressed and wears a safety line securely attached to the guardrail;
- .6 bear in mind that the work of the crew on ice clearing entails the danger of frost-bite. For this reason it is necessary to make sure that members of the crew working on deck are replaced periodically;
- .7 keep the following structures and gears of the vessel first free from ice:
 - .7.1 aerials;
 - .7.2 running and navigational lights;
 - .7.3 freeing ports and scuppers;
 - .7.4 lifesaving craft;
 - .7.5 stays, shrouds, masts and rigging;
 - .7.6 doors of superstructures and deck-houses; and
 - .7.7 windlass and hawse holes;
- .8 remove the ice from large surfaces of the vessel, beginning with the upper structures (such as bridges, deck-houses, etc.), because even a small amount of ice on them causes a drastic worsening of the vessel's stability;
- .9 when the distribution of ice is not symmetrical and a list develops, the ice must be cleared from the lower side first. Bear in mind that any correction of the list of the vessel by pumping fuel or water from one tank to another may reduce stability during the process when both tanks are slack;
- .10 when a considerable amount of ice forms on the bow and a trim appears, ice must be quickly removed. Water ballast may be redistributed in order to decrease the trim;

- .11 clear ice from the freeing ports and scuppers in due time in order to ensure free drainage of the water from the deck;
- .12 check regularly for water accumulation inside the hull;
- .13 avoid navigating in following seas since this may drastically worsen the vessel's stability;
- .14 register in the vessel's log-book the duration, nature and intensity of ice formation, amount of ice on the vessel, measures taken to combat ice formation and their effectiveness; and
- .15 if, in spite of all the measures taken to ensure the vessel's endurance in conditions of ice formation, the crew is forced to abandon the vessel and embark on life-saving craft (lifeboats, rafts) then, in order to preserve their lives, it is necessary to do all possible to provide all the crew with warm clothing or special bags as well as to have a sufficient number of lifelines and bailers for speedy bailing out of water from the life-saving craft.

4 List of equipment and hand tools

A typical list of equipment and hand tools required for combating ice formation:

- .1 ice crows or crowbars;
- .2 axes with long handles;
- .3 picks;
- .4 metal scrapers;
- .5 metal shovels;
- .6 wooden sledge-hammers;
- .7 fore and aft lifelines to be rigged each side of the open deck fitted with travellers to which lizards can be attached.

Safety belts with spring hooks should be provided for no less than 50% of the members of the crew (but not less than 5 sets), which can be attached to the lizards.

- Notes:*
- 1 The number of hand tools and lifesaving appliances may be increased, at the shipowner's discretion.
 - 2 Hoses which may be used for ice combating should be readily available on board.

ANNEX 4**RESOLUTION MSC.269(85)
(adopted on 4 December 2008)****ADOPTION OF AMENDMENTS TO THE INTERNATIONAL CONVENTION FOR
THE SAFETY OF LIFE AT SEA, 1974, AS AMENDED**

THE MARITIME SAFETY COMMITTEE,

RECALLING Article 28(b) of the Convention on the International Maritime Organization concerning the functions of the Committee,

RECALLING FURTHER article VIII(b) of the International Convention for the Safety of Life at Sea (SOLAS), 1974 (hereinafter referred to as “the Convention”), concerning the amendment procedure applicable to the Annex to the Convention, other than to the provisions of chapter I thereof,

HAVING CONSIDERED, at its eighty-fifth session, amendments to the Convention, proposed and circulated in accordance with article VIII(b)(i) thereof,

1. ADOPTS, in accordance with article VIII(b)(iv) of the Convention, amendments to the Convention, the text of which is set out in Annexes 1 and 2 to the present resolution;
2. DETERMINES, in accordance with article VIII(b)(vi)(2)(bb) of the Convention, that:
 - (a) the said amendments, set out in Annex 1, shall be deemed to have been accepted on 1 January 2010; and
 - (b) the said amendments, set out in Annex 2, shall be deemed to have been accepted on 1 July 2010,

unless, prior to those dates, more than one third of the Contracting Governments to the Convention or Contracting Governments the combined merchant fleets of which constitute not less than 50% of the gross tonnage of the world’s merchant fleet, have notified their objections to the amendments;

3. INVITES Contracting Governments to the Convention to note that, in accordance with article VIII(b)(vii)(2) of the Convention:
 - (a) the amendments, set out in Annex 1, shall enter into force on 1 July 2010; and
 - (b) the amendments, set out in Annex 2, shall enter into force on 1 January 2011,

upon their acceptance in accordance with paragraph 2 above;

4. REQUESTS the Secretary-General, in conformity with article VIII(b)(v) of the Convention, to transmit certified copies of the present resolution and the text of the amendments contained in Annexes 1 and 2 to all Contracting Governments to the Convention;

5. FURTHER REQUESTS the Secretary-General to transmit copies of this resolution and its Annexes 1 and 2 to Members of the Organization, which are not Contracting Governments to the Convention.

ANNEX 1

**AMENDMENTS TO THE INTERNATIONAL CONVENTION FOR THE SAFETY OF
LIFE AT SEA, 1974, AS AMENDED**

**CHAPTER II-1
CONSTRUCTION – STRUCTURE, SUBDIVISION AND STABILITY, MACHINERY
AND ELECTRICAL INSTALLATIONS**

**Part A
General**

Regulation 2 – Definitions

1 The following new paragraph 27 is added after the existing paragraph 26:

“27 *2008 IS Code* means the International Code on Intact Stability, 2008, consisting of an introduction, part A (the provisions of which shall be treated as mandatory) and part B (the provisions of which shall be treated as recommendatory), as adopted by resolution MSC.267(85), provided that:

- .1 amendments to the introduction and part A of the Code are adopted, brought into force and take effect in accordance with the provisions of article VIII of the present Convention concerning the amendment procedures applicable to the Annex other than chapter I thereof; and
- .2 amendments to part B of the Code are adopted by the Maritime Safety Committee in accordance with its Rules of Procedure.”

**Part B-1
Stability**

Regulation 5 – Intact stability information

2 In the existing title of the regulation, the word “information” is deleted.

3 In paragraph 1, the following new sentence is added after the existing sentence:

“In addition to any other applicable requirements of the present regulations, ships having a length of 24 m and upwards constructed on or after 1 July 2010 shall as a minimum comply with the requirements of part A of the 2008 IS Code.”

**CHAPTER II-2
CONSTRUCTION – FIRE PROTECTION, FIRE DETECTION AND
FIRE EXTINCTION**

**Part A
General**

Regulation 1 – Application

4 The following new paragraph 2.3 is added:

“2.3 Ships constructed on or after 1 July 2002 and before 1 July 2010 shall comply with paragraphs 7.1.1, 7.4.4.2, 7.4.4.3 and 7.5.2.1.2 of regulation 9, as adopted by resolution MSC.99(73).”

**Part C
Suppression of fire**

Regulation 9 – Containment of fire

5 The last sentence of paragraph 4.1.1.2 is moved to a new separate paragraph 4.1.1.3 and the existing following paragraphs are renumbered accordingly.

6 The following text is added at the end of paragraph 4.1.1.2:

“Doors approved without the sill being part of the frame, which are installed on or after 1 July 2010, shall be installed such that the gap under the door does not exceed 12 mm. A non-combustible sill shall be installed under the door such that floor coverings do not extend beneath the closed door.”

7 The following text is added at the end of paragraph 4.1.2.1:

“Doors approved without the sill being part of the frame, which are installed on or after 1 July 2010, shall be installed such that the gap under the door does not exceed 25 mm.”

8 In paragraph 4.2.1, the following text is added after the first sentence:

“Doors approved as “A” class without the sill being part of the frame, which are installed on or after 1 July 2010, shall be installed such that the gap under the door does not exceed 12 mm and a non-combustible sill shall be installed under the door such that floor coverings do not extend beneath the closed door. Doors approved as “B” class without the sill being part of the frame, which are installed on or after 1 July 2010, shall be installed such that the gap under the door does not exceed 25 mm.”

9 In paragraph 7.1.1, in the first and second sentences, the words “non-combustible” are replaced by the words “steel or equivalent”.

10 At the beginning of paragraph 7.1.1.1, the words “subject to paragraph 7.1.1.2” are added and the word “a” before the word “material” is replaced by the word “any”.

11 The following new paragraph 7.1.1.2 is added after the existing paragraph 7.1.1.1 and the existing subsequent paragraphs are renumbered accordingly:

“2 on ships constructed on or after 1 July 2010, the ducts shall be made of heat resisting non-combustible material, which may be faced internally and externally with membranes having low flame-spread characteristics and, in each case, a calorific value** not exceeding 45 MJ/m² of their surface area for the thickness used;”

** Refer to the recommendations published by the International Organization for Standardization, in particular publication ISO 1716:2002, *Determination of calorific potential*.

12 In paragraph 7.4.4.2, the words “non-combustible” are replaced by the words “steel or equivalent”.

13 In paragraph 7.4.4.3, the words “non-combustible” are replaced by the words “steel or equivalent”.

14 At the beginning of paragraph 7.4.4.3.1, the words “subject to paragraph 7.4.4.3.2” are added and the word “a” before the word “material” is replaced by the word “any”.

15 The following new paragraph 7.4.4.3.2 is added after the existing paragraph 7.4.4.3.1 and the existing subsequent paragraphs are renumbered accordingly:

“3.2 on ships constructed on or after 1 July 2010, the ducts shall be made of heat resisting non-combustible material, which may be faced internally and externally with membranes having low flame-spread characteristics and, in each case, a calorific value* not exceeding 45 MJ/m² of their surface area for the thickness used;”

* Refer to the recommendations published by the International Organization for Standardization, in particular publication ISO 1716:2002, *Determination of calorific potential*.

16 At the end of paragraph 7.5.2.1.2, the words “and, in addition, a fire damper in the upper end of the duct” are added.

Regulation 10 – Fire fighting

17 The following new paragraph 10.2.6 is inserted after the existing paragraph 10.2.5:

“10.2.6 Passenger ships carrying more than 36 passengers constructed on or after 1 July 2010 shall be fitted with a suitably located means for fully recharging breathing air cylinders, free from contamination. The means for recharging shall be either:

- .1 breathing air compressors supplied from the main and emergency switchboard, or independently driven, with a minimum capacity of 60 l/min per required breathing apparatus, not to exceed 420 l/min; or
- .2 self-contained high-pressure storage systems of suitable pressure to recharge the breathing apparatus used on board, with a capacity of at least 1,200 l per required breathing apparatus, not to exceed 50,000 l of free air.”

ANNEX 2

**AMENDMENTS TO THE INTERNATIONAL CONVENTION FOR THE SAFETY OF
LIFE AT SEA, 1974, AS AMENDED**

**CHAPTER II-2
CONSTRUCTION – FIRE PROTECTION, FIRE DETECTION AND
FIRE EXTINCTION**

**Part A
General**

Regulation 1 – Application

1 The following new paragraph 2.4 is added after the existing paragraph 2.3:

“2.4 The following ships, with cargo spaces intended for the carriage of packaged dangerous goods, shall comply with regulation 19.3, except when carrying dangerous goods specified as classes 6.2 and 7 and dangerous goods in limited quantities* and excepted quantities** in accordance with tables 19.1 and 19.3, not later than the date of the first renewal survey on or after the 1 January 2011:

- .1 cargo ships of 500 gross tonnage and upwards and passenger ships constructed on or after 1 September 1984 but before 1 January 2011; and
- .2 cargo ships of less than 500 gross tonnage constructed on or after 1 February 1992 but before 1 January 2011,

and notwithstanding these provisions:

- .3 cargo ships of 500 gross tonnage and upwards and passenger ships constructed on or after 1 September 1984 but before 1 July 1986 need not comply with regulation 19.3.3 provided that they comply with regulation 54.2.3 as adopted by resolution MSC.1(XLV);
- .4 cargo ships of 500 gross tonnage and upwards and passenger ships constructed on or after 1 July 1986 but before 1 February 1992 need not comply with regulation 19.3.3 provided that they comply with regulation 54.2.3 as adopted by resolution MSC.6(48);
- .5 cargo ships of 500 gross tonnage and upwards and passenger ships constructed on or after 1 September 1984 but before 1 July 1998 need not comply with regulations 19.3.10.1 and 19.3.10.2; and
- .6 cargo ships of less than 500 gross tonnage constructed on or after 1 February 1992 but before 1 July 1998 need not comply with regulations 19.3.10.1 and 19.3.10.2.”

* Refer to chapter 3.4 of the IMDG Code.

** Refer to chapter 3.5 of the IMDG Code.

Part E
Operational requirements

Regulation 16 – Operations

2 In paragraph 2.1, the reference to “the Code of Safe Practice for Solid Bulk Cargoes” is replaced by the reference to “the International Maritime Solid Bulk Cargoes (IMSBC) Code”.

Part G
Special requirements

Regulation 19 – Carriage of dangerous goods

3 The existing note 1 to table 19.1 is replaced by the following:

“¹ For classes 4 and 5.1 solids not applicable to closed freight containers. For classes 2, 3, 6.1 and 8 when carried in closed freight containers, the ventilation rate may be reduced to not less than two air changes per hour. For classes 4 and 5.1 liquids when carried in closed freight containers, the ventilation rate may be reduced to not less than two air changes per hour. For the purpose of this requirement, a portable tank is a closed freight container.”

4 In note 10 to table 19.2, the words “the Code of Safe Practice for Solid Bulk Cargoes, adopted by resolution A.434(XI)” are replaced by the words “the International Maritime Solid Bulk Cargoes (IMSBC) Code”.

5 The existing table 19.3 is replaced by the following table:

“Table 19.3 – Application of the requirements to different classes of dangerous goods except solid dangerous goods in bulk

Class	Regulation 19																						
	1.1 to 1.6	1.4S	2.1	2.2	2.3 flammable ²⁰	2.3 non-flammable	3 FP ¹⁵ < 23°C	3 FP ¹⁵ ≥ 23°C to ≤ 60°C	4.1	4.2	4.3 liquids ²¹	4.3 solids	5.1	5.2 ¹⁶	6.1 liquids FP ¹⁵ < 23°C	6.1 liquids FP ¹⁵ ≥ 23°C to ≤ 60°C	6.1 liquids	6.1 solids	8 liquids FP ¹⁵ < 23°C	8 liquids FP ¹⁵ ≥ 23°C to ≤ 60°C	8 liquids	8 solids	9
3.1.1	X	X	X	X	X	X	X	X	X	X	X	X	X	X	X	X	X	X	X	X	X	X	X
3.1.2	X	X	X	X	X	X	X	X	X	X	X	X	X	X	X	X	X	X	X	X	X	X	-
3.1.3	X	-	-	-	-	-	-	-	-	-	-	-	-	-	-	-	-	-	-	-	-	-	-
3.1.4	X	-	-	-	-	-	-	-	-	-	-	-	-	-	-	-	-	-	-	-	-	-	-
3.2	X	-	X	-	X	-	X	-	-	-	X ¹⁸	-	-	-	X	-	-	-	X	-	-	-	X ¹⁷
3.3	X	X	X	X	-	X	X	X	X	X	X	X	X	-	X	X	X	X	X	X	X	X	-
3.4.1	-	-	X	-	-	X	X	-	X ¹¹	X ¹¹	X	X	X ¹¹	-	X	X	-	X ¹¹	X	X	-	-	X ¹¹
3.4.2	-	-	X	-	-	-	X	-	-	-	-	-	-	-	X	-	-	-	X	-	-	-	X ¹⁷
3.5	-	-	-	-	-	-	X	-	-	-	-	-	-	-	X	X	X	-	X	X ¹⁹	X ¹⁹	-	-
3.6	-	-	X	X	X	X	X	X	X	X	X	X	X	X	X	X	X	X	X	X	X	X	X ¹⁴
3.7	-	-	-	-	-	-	X	X	X	X	X	X	X	-	X	X	-	-	X	X	-	-	-
3.8	X ¹²	-	X	X	X	X	X	X	X	X	X	X	X ¹³	X	X	X	-	-	X	X	-	-	-
3.9	X	X	X	X	X	X	X	X	X	X	X	X	X	X	X	X	X	X	X	X	X	X	X
3.10.1	X	X	X	X	X	X	X	X	X	X	X	X	X	X	X	X	X	X	X	X	X	X	X
3.10.2	X	X	X	X	X	X	X	X	X	X	X	X	X	X	X	X	X	X	X	X	X	X	X

- ¹¹ When “mechanically-ventilated spaces” are required by the IMDG Code.
- ¹² Stow 3 m horizontally away from the machinery space boundaries in all cases.
- ¹³ Refer to the IMDG Code.
- ¹⁴ As appropriate for the goods to be carried.
- ¹⁵ FP means flashpoint.
- ¹⁶ Under the provisions of the IMDG Code, stowage of class 5.2 dangerous goods under deck or in enclosed ro-ro spaces is prohibited.
- ¹⁷ Only applicable to dangerous goods evolving flammable vapour listed in the IMDG Code.

- ¹⁸ Only applicable to dangerous goods having a flashpoint less than 23°C listed in the IMDG Code.
- ¹⁹ Only applicable to dangerous goods having a subsidiary risk class 6.1.
- ²⁰ Under the provisions of the IMDG Code, stowage of class 2.3 having subsidiary risk class 2.1 under deck or in enclosed ro-ro spaces is prohibited.
- ²¹ Under the provisions of the IMDG Code, stowage of class 4.3 liquids having a flashpoint less than 23°C under deck or in enclosed ro-ro spaces is prohibited.”

6 In paragraph 2.1, after the words “except when carrying dangerous goods in limited quantities”, the following words are added:

“and excepted quantities^{*}”.

* Refer to chapter 3.5 of the IMDG Code.

7 In paragraph 3.4, the existing title is replaced as follows:

“3.4 *Ventilation arrangement*”.

8 The following text is added at the end of the first sentence of paragraph 3.6.1:

“and shall be selected taking into account the hazards associated with the chemicals being transported and the standards developed by the Organization according to the class and physical state^{*}.”

* For solid bulk cargoes, the protective clothing should satisfy the equipment provisions specified in the respective schedules of the IMSBC Code for the individual substances. For packaged goods, the protective clothing should satisfy the equipment provisions specified in emergency procedures (EmS) of the Supplement to the IMDG Code for the individual substances.

9 At the end of paragraph 4, the words “and excepted quantities” are added.

CHAPTER VI CARRIAGE OF CARGOES

Part A General provisions

10 The following new regulations 1-1 and 1-2 are added after the existing regulation 1:

“Regulation 1-1 Definitions

For the purpose of this chapter, unless expressly provided otherwise, the following definitions shall apply:

1 *IMSBC Code* means the International Maritime Solid Bulk Cargoes (IMSBC) Code adopted by the Maritime Safety Committee of the Organization by resolution MSC.268(85), as may be amended by the Organization, provided that such amendments are adopted, brought into force and take effect in accordance with the provisions of article VIII of the present Convention concerning the amendment procedures applicable to the Annex other than chapter I.

2 *Solid bulk cargo* means any cargo, other than liquid or gas, consisting of a combination of particles, granules or any larger pieces of material generally uniform in composition, which is loaded directly into the cargo spaces of a ship without any intermediate form of containment.

Regulation 1-2 Requirements for the carriage of solid bulk cargoes other than grain

The carriage of solid bulk cargoes other than grain shall be in compliance with the relevant provisions of the IMSBC Code.”

Regulation 2 – Cargo information

11 The existing subparagraph .2 of paragraph 2 is replaced by the following:

“.2 in the case of solid bulk cargo, information as required by section 4 of the IMSBC Code.”

12 The existing paragraph 2.3 is deleted.

Regulation 3 – Oxygen analysis and gas detection equipment

13 In paragraph 1, the word “solid” is inserted in the first sentence, after the words “When transporting a”.

Part B Special provisions for bulk cargoes other than grain

14 The title of part B is replaced as follows:

“Special provisions for solid bulk cargoes”

Regulation 6 – Acceptability for shipment

15 In existing paragraph 1, the word “solid” is inserted in the first sentence after the words “Prior to loading a”.

16 The existing paragraphs 2 and 3 are deleted.

Regulation 7 – Loading, unloading and stowage of bulk cargoes

17 In the heading of the regulation, the word “solid” is inserted after the words “stowage of”.

18 The existing paragraphs 4 and 5 are deleted and the subsequent paragraphs are renumbered accordingly.

**CHAPTER VII
CARRIAGE OF DANGEROUS GOODS**

**Part A-1
Carriage of dangerous goods in solid form in bulk**

Regulation 7-1 – Application

19 In paragraph 3 of the regulation, the words “detailed instructions on the safe carriage of dangerous goods in solid form in bulk which shall include” are deleted.

20 The following new regulation 7-5 is inserted after regulation 7-4:

**“Regulation 7-5
Requirements for the carriage of dangerous goods in solid form in bulk**

The carriage of dangerous goods in solid form in bulk shall be in compliance with the relevant provisions of the IMSBC Code, as defined in regulation VI/1-1.1.”

ANNEX 5

**RESOLUTION MSC.270(85)
(adopted on 4 December 2008)**

**ADOPTION OF AMENDMENTS TO THE PROTOCOL OF 1988 RELATING TO
THE INTERNATIONAL CONVENTION ON LOAD LINES, 1966, AS AMENDED**

THE MARITIME SAFETY COMMITTEE,

RECALLING Article 28(b) of the Convention on the International Maritime Organization concerning the functions of the Committee,

RECALLING FURTHER article VI of the Protocol of 1988 relating to the International Convention on Load Lines, 1966 (hereinafter referred to as the "1988 Load Lines Protocol") concerning amendment procedures,

HAVING CONSIDERED, at its eighty-fifth session, amendments to the 1988 Load Lines Protocol proposed and circulated in accordance with paragraph 2(a) of article VI thereof,

1. ADOPTS, in accordance with paragraph 2(d) of article VI of the 1988 Load Lines Protocol, amendments to the 1988 Load Lines Protocol, the text of which is set out in the Annex to the present resolution;
2. DETERMINES, in accordance with paragraph 2(f)(ii)(bb) of article VI of the 1988 Load Lines Protocol, that the said amendments shall be deemed to have been accepted on 1 January 2010, unless, prior to that date, more than one third of the Parties to the 1988 Load Lines Protocol or Parties the combined merchant fleets of which constitute not less than 50% of the gross tonnage of the world's merchant fleet, have notified their objections to the amendments;
3. INVITES the Parties concerned to note that, in accordance with paragraph 2(g)(ii) of article VI of the 1988 Load Lines Protocol, the amendments shall enter into force on 1 July 2010 upon their acceptance in accordance with paragraph 2 above;
4. REQUESTS the Secretary-General, in conformity with paragraph 2(e) of article VI of the 1988 Load Lines Protocol, to transmit certified copies of the present resolution and the text of the amendments contained in the Annex to all Parties to the 1988 Load Lines Protocol;
5. FURTHER REQUESTS the Secretary-General to transmit copies of this resolution and its Annex to Members of the Organization, which are not Parties to the 1988 Load Lines Protocol.

ANNEX

**AMENDMENTS TO THE PROTOCOL OF 1988 RELATING TO THE
INTERNATIONAL CONVENTION ON LOAD LINES, 1966, AS AMENDED**

**ANNEX B
ANNEXES TO THE CONVENTION AS MODIFIED BY THE PROTOCOL OF 1988
RELATING THERETO**

**ANNEX I
REGULATIONS FOR DETERMINING LOAD LINES**

**CHAPTER I
GENERAL**

Regulation 1 – Strength and intact stability of ships

1 The existing text of paragraph (3) is replaced by the following:

“(3) *Compliance*

- (a) Ships constructed before 1 July 2010 shall comply with an intact stability standard acceptable to the Administration.
- (b) Ships constructed on or after 1 July 2010 shall, as a minimum, comply with the requirements of part A of the 2008 IS Code.”

Regulation 3 – Definitions of terms used in the Annexes

2 The following new paragraph (16) is added after the existing paragraph (15):

“(16) *2008 IS Code* means the International Code on Intact Stability, 2008, consisting of an introduction, part A (the provisions of which shall be treated as mandatory) and part B (the provisions of which shall be treated as recommendatory), as adopted by resolution MSC.267(85), provided that:

- .1 amendments to the introduction and part A of the Code are adopted, brought into force and take effect in accordance with the provisions of article VI of the 1988 Load Lines Protocol concerning the amendment procedure applicable to Annex B to the Protocol; and
- .2 amendments to part B of the Code are adopted by the Maritime Safety Committee in accordance with its Rules of Procedure.”

ANNEX 6**RESOLUTION MSC.271(85)
(adopted on 4 December 2008)****ADOPTION OF AMENDMENTS TO THE INTERNATIONAL CODE OF SAFETY
FOR HIGH-SPEED CRAFT, 2000 (2000 HSC CODE)**

THE MARITIME SAFETY COMMITTEE,

RECALLING Article 28(b) of the Convention on the International Maritime Organization concerning the functions of the Committee,

NOTING resolution MSC.97(73), by which it adopted the International Code of Safety for High-Speed Craft, 2000 (hereinafter referred to as “the 2000 HSC Code”), which has become mandatory under chapter X of the International Convention for the Safety of Life at Sea (SOLAS), 1974 (hereinafter referred to as “the Convention”),

NOTING ALSO article VIII(b) and regulation X/1.1 of the Convention concerning the procedure for amending the 1994 HSC Code,

HAVING CONSIDERED, at its eighty-fifth session, amendments to the 2000 HSC Code proposed and circulated in accordance with article VIII(b)(i) of the Convention,

1. ADOPTS, in accordance with article VIII(b)(iv) of the Convention, amendments to the 2000 HSC Code, the text of which is set out in the Annex to the present resolution;
2. DETERMINES, in accordance with article VIII(b)(vi)(2)(bb) of the Convention, that the amendments shall be deemed to have been accepted on 1 July 2010 unless, prior to that date, more than one third of the Contracting Governments to the Convention or Contracting Governments the combined merchant fleets of which constitute not less than 50% of the gross tonnage of the world’s merchant fleet, have notified their objections to the amendments;
3. INVITES Contracting Governments to note that, in accordance with article VIII(b)(vii)(2) of the Convention, the amendments shall enter into force on 1 January 2011 upon their acceptance in accordance with paragraph 2 above;
4. REQUESTS the Secretary-General, in conformity with article VIII(b)(v) of the Convention, to transmit certified copies of the present resolution and the text of the amendments contained in the Annex to all Contracting Governments to the Convention;
5. FURTHER REQUESTS the Secretary-General to transmit copies of this resolution and its Annex to Members of the Organization, which are not Contracting Governments to the Convention.

ANNEX

**AMENDMENTS TO THE INTERNATIONAL CODE OF SAFETY FOR
HIGH-SPEED CRAFT, 2000 (2000 HSC CODE)**

**CHAPTER 7
FIRE SAFETY**

- 1 At the end of paragraph 7.17.1, the following new sentence is added:

“Craft constructed on or after 1 July 2002 but before 1 January 2011, with cargo spaces intended for the carriage of packaged dangerous goods, shall comply with 7.13.3, except when carrying dangerous goods specified as classes 6.2 and 7 and dangerous goods in limited quantities* and excepted quantities** in accordance with tables 7.17-1 and 7.17-3, not later than the date of the first renewal survey on or after 1 January 2011.”

* Refer to chapter 3.4 of the IMDG Code.

** Refer to chapter 3.5 of the IMDG Code.

- 2 The existing note 1 to table 7.17-1 is replaced by the following:

“¹ For classes 4 and 5.1 solids not applicable to closed freight containers. For classes 2, 3, 6.1 and 8 when carried in closed freight containers the ventilation rate may be reduced to not less than two air changes per hour. For classes 4 and 5.1 liquids when carried in closed freight containers, the ventilation rate may be reduced to not less than two air changes per hour. For the purpose of this requirement a portable tank is a closed freight container.”

3 The existing table 7.17-3 is replaced by the following:

“Table 7.17-3

Application of the requirements of section 7.17.3 to different classes of dangerous goods except solid dangerous goods in bulk

Section \ Class	Class																							
	1.1 to 1.6 ⁹	1.4S	2.1	2.2	2.3 flammable ¹⁷	2.3 non-flammable	3 FP ¹² < 23°C	3 FP ¹² ≥ 23°C to ≤ 60°C	4.1	4.2	4.3 liquids ¹⁸	4.3 solids	5.1 ¹⁰	5.2 ¹³	6.1 liquids FP ¹² < 23°C	6.1 liquids FP ¹² ≥ 23°C to ≤ 60°C	6.1 liquids	6.1 solids	8 liquids FP ¹² < 23°C	8 liquids FP ¹² ≥ 23°C to ≤ 60°C	8 liquids	8 solids	9	
7.17.3.1.1	X	X	X	X	X	X	X	X	X	X	X	X	X	X	X	X	X	X	X	X	X	X	X	X
7.17.3.1.2	X	X	X	X	X	X	X	X	X	X	X	X	X	X	X	X	X	X	X	X	X	X	X	-
7.17.3.1.3	X	-	-	-	-	-	-	-	-	-	-	-	-	-	-	-	-	-	-	-	-	-	-	-
7.17.3.1.4	X	-	-	-	-	-	-	-	-	-	-	-	-	-	-	-	-	-	-	-	-	-	-	-
7.17.3.2	X	-	X	-	X	-	X	-	-	-	X ¹⁵	-	-	-	X	-	-	-	X	-	-	-	X ¹⁴	
7.17.3.3	X	X	X	X	-	X	X	X	X	X	X	X	X	-	X	X	X	X	X	X	X	X	X	-
7.17.3.4.1	-	-	X	-	-	X	X	-	X ⁸	X ⁸	X	X	X ⁸	-	X	X	-	X ⁸	X	X	-	-	X ⁸	
7.17.3.4.2	-	-	X	-	-	-	X	-	-	-	-	-	-	-	X	-	-	-	X	-	-	-	X ¹⁴	
7.17.3.5	-	-	-	-	-	-	X	-	-	-	-	-	-	-	X	X	X	-	X	X ¹⁶	X ¹⁶	-	-	
7.17.3.6	-	-	X	X	X	X	X	X	X	X	X	X	X	X	X	X	X	X	X	X	X	X	X ¹¹	
7.17.3.7	-	-	-	-	-	-	X	X	X	X	X	X	X	-	X	X	-	-	X	X	-	-	-	
7.17.3.8	X ⁹	X	X	X	X	X	X	X	X	X	X	X	X ¹⁰	X	X	X	X	X	X	X	X	X	X	
7.17.3.9	X	X	X	X	X	X	X	X	X	X	X	X	X	X	X	X	X	X	X	X	X	X	X	
7.17.3.10	X	X	X	X	X	X	X	X	X	X	X	X	X	X	X	X	X	X	X	X	X	X	X	

⁸ When “mechanically-ventilated spaces” are required by the IMDG Code.

⁹ Stow 3 m horizontally away from the machinery space boundaries in all cases.

¹⁰ Refer to the IMDG Code.

¹¹ As appropriate for the goods to be carried.

¹² FP means flashpoint.

¹³ Under the provisions of the IMDG Code, stowage of class 5.2 dangerous goods under deck or in enclosed ro-ro spaces is prohibited.

- ¹⁴ Only applicable to dangerous goods evolving flammable vapour listed in the IMDG Code.
- ¹⁵ Only applicable to dangerous goods having a flashpoint less than 23°C listed in the IMDG Code.
- ¹⁶ Only applicable to dangerous goods having a subsidiary risk class 6.1.
- ¹⁷ Under the provisions of the IMDG Code, stowage of class 2.3 having subsidiary risk class 2.1 under deck or in enclosed ro-ro spaces is prohibited.
- ¹⁸ Under the provisions of the IMDG Code, stowage of class 4.3 liquids having a flashpoint less than 23°C under deck or in enclosed ro-ro spaces is prohibited.”

4 In paragraph 7.17.1, after the words “except when carrying dangerous goods in limited quantities”, the following words are added:

“and excepted quantities^{*}”.

* Refer to chapter 3.5 of the IMDG Code.

ANNEX 7

**RESOLUTION MSC.272(85)
(adopted on 4 December 2008)****ADOPTION OF AMENDMENTS TO THE
INTERNATIONAL LIFE-SAVING APPLIANCE (LSA) CODE**

THE MARITIME SAFETY COMMITTEE,

RECALLING Article 28(b) of the Convention on the International Maritime Organization concerning the functions of the Committee,

NOTING resolution MSC.48(66), by which it adopted the International Life-Saving Appliance Code (hereinafter referred to as “the LSA Code”), which has become mandatory under chapter III of the International Convention for the Safety of Life at Sea, 1974 (hereinafter referred to as “the Convention”),

NOTING ALSO article VIII(b) and regulation III/3.10 of the Convention concerning the procedure for amending the LSA Code,

HAVING CONSIDERED, at its [eighty-fifth] session, amendments to the LSA Code, proposed and circulated in accordance with article VIII(b)(i) of the Convention,

1. ADOPTS, in accordance with article VIII(b)(iv) of the Convention, amendments to the LSA Code, the text of which is set out in the Annex to the present resolution;
2. DETERMINES, in accordance with article VIII(b)(vi)(2)(bb) of the Convention, that the amendments shall be deemed to have been accepted on 1 January 2010 unless, prior to that date, more than one third of the Contracting Governments to the Convention or Contracting Governments the combined merchant fleets of which constitute not less than 50% of the gross tonnage of the world’s merchant fleet, have notified their objections to the amendments;
3. INVITES Contracting Governments to note that, in accordance with article VIII(b)(vii)(2) of the Convention, the amendments shall enter into force on 1 July 2010 upon their acceptance in accordance with paragraph 2 above;
4. REQUESTS the Secretary-General, in conformity with article VIII(b)(v) of the Convention, to transmit certified copies of the present resolution and the text of the amendments contained in the Annex to all Contracting Governments to the Convention;
5. FURTHER REQUESTS the Secretary-General to transmit copies of this resolution and its Annex to Members of the Organization, which are not Contracting Governments to the Convention.

ANNEX

**AMENDMENTS TO THE INTERNATIONAL
LIFE-SAVING APPLIANCE (LSA) CODE**

**CHAPTER IV
SURVIVAL CRAFT**

4.4 General requirements for lifeboats

1 In subparagraph .1 of paragraph 4.4.2.2, the words “(for a lifeboat intended for a passenger ship) or 82.5 kg (for a lifeboat intended for a cargo ship)” are inserted after the words “75 kg”.

2 The existing paragraph 4.4.9.1 is replaced by the following:

“4.4.9.1 The number(s) of persons for which the lifeboat is approved, for passenger ships and/or cargo ships, as applicable, shall be clearly marked on it in clear permanent characters.”

4.7 Free-fall lifeboats

3 The existing paragraph 4.7.2 is replaced by the following:

“4.7.2 Carrying capacity of a free-fall lifeboat

4.7.2.1 The carrying capacity of a free-fall lifeboat is the number of persons having an average mass of 82.5 kg that can be provided with a seat without interfering with the means of propulsion or the operation of any of the lifeboat’s equipment. The seating surface shall be smooth and shaped and provided with cushioning of at least 10 mm over all contact areas to provide support for the back and pelvis and flexible lateral side support for the head. The seats shall be of the non-folding type, permanently secured to the lifeboat and arranged so that any deflection of the hull or canopy during launching will not cause injury to the occupants. The location and structure of the seat shall be arranged to preclude the potential for injury during launch if the seat is narrower than the occupant’s shoulders. The passage between the seats shall have a clear width of at least 480 mm from the deck to the top of the seats, be free of any obstruction and provided with an antislip surface with suitable footholds to allow safe embarkation in the ready-to-launch position. Each seat shall be provided with a suitable locking harness capable of quick release under tension to restrain the body of the occupant during launching.

4.7.2.2 The angle between the seat pan and the seat back shall be at least 90°. The width of the seat pan shall be at least 480 mm. Free clearance in front of the backrest (buttock to knee length) shall be at least 650 mm measured at an angle of 90° to the backrest. The backrest shall extend at least 1,075 mm above the seat pan. The seat shall provide for shoulder height, measured along the seat back, of at least 760 mm. The footrest shall be oriented at not less than half of the angle of the seat pan and shall have a foot length of at least 330 mm (see figure 2).

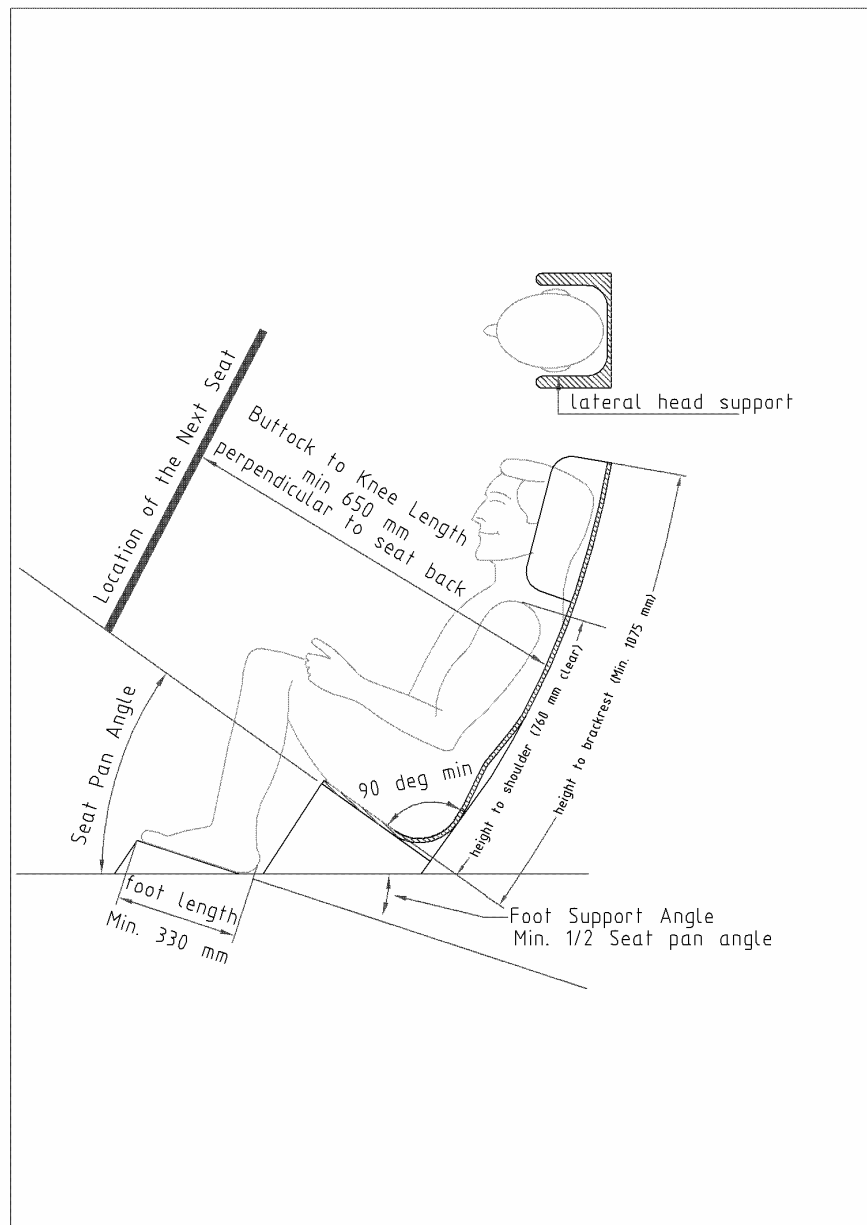

Figure 2”

CHAPTER V RESCUE BOATS

5.1 Rescue boats

4 In the first sentence of paragraph 5.1.1.1, the words “, except that, for all rescue boats, an average mass of 82.5 kg shall apply to paragraph 4.4.2.2.1” are added after the reference to “4.4.9”.

5 In the second sentence of paragraph 5.1.3.5, the words “75 kg” are replaced by the words “82.5 kg”.

ANNEX 8**RESOLUTION MSC.273(85)
(adopted on 4 December 2008)****ADOPTION OF AMENDMENTS TO THE INTERNATIONAL MANAGEMENT CODE
FOR THE SAFE OPERATION OF SHIPS AND FOR POLLUTION PREVENTION
(INTERNATIONAL SAFETY MANAGEMENT (ISM) CODE)**

THE MARITIME SAFETY COMMITTEE,

RECALLING Article 28(b) of the Convention on the International Maritime Organization concerning the functions of the Committee,

NOTING resolution A.741(18), by which the Assembly adopted the International Management Code for the Safe Operation of Ships and for Pollution Prevention (International Safety Management (ISM) Code) (hereinafter referred to as “the ISM Code”), which has become mandatory under chapter IX of the International Convention for the Safety of Life at Sea (SOLAS), 1974 (hereinafter referred to as “the Convention”),

NOTING ALSO article VIII(b) and regulation IX/1.1 of the Convention concerning the procedure for amending the ISM Code,

HAVING CONSIDERED, at its eighty-fifth session, amendments to the ISM Code proposed and circulated in accordance with article VIII(b)(i) of the Convention,

1. ADOPTS, in accordance with article VIII(b)(iv) of the Convention, amendments to the ISM Code, the text of which is set out in the Annex to the present resolution;
2. DETERMINES, in accordance with article VIII(b)(vi)(2)(bb) of the Convention, that the amendments shall be deemed to have been accepted on 1 January 2010 unless, prior to that date, more than one third of the Contracting Governments to the Convention or Contracting Governments the combined merchant fleets of which constitute not less than 50% of the gross tonnage of the world’s merchant fleet, have notified their objections to the amendments;
3. INVITES Contracting Governments to note that, in accordance with article VIII(b)(vii)(2) of the Convention, the amendments shall enter into force on 1 July 2010 upon their acceptance in accordance with paragraph 2 above;
4. REQUESTS the Secretary-General, in conformity with article VIII(b)(v) of the Convention, to transmit certified copies of the present resolution and the text of the amendments contained in the Annex to all Contracting Governments to the Convention;
5. FURTHER REQUESTS the Secretary-General to transmit copies of this resolution and its Annex to Members of the Organization, which are not Contracting Governments to the Convention.

ANNEX

**AMENDMENTS TO THE INTERNATIONAL MANAGEMENT CODE FOR
THE SAFE OPERATION OF SHIPS AND FOR POLLUTION PREVENTION
(INTERNATIONAL SAFETY MANAGEMENT (ISM) CODE)**

1 GENERAL

Section 1.1 Definitions

1 In paragraph 1.1.10, the words “and includes” are replaced by the word “or”.

Section 1.2 Objectives

2 The existing subparagraph .2 of paragraph 1.2.2 is replaced by the following:

“2 assess all identified risks to its ships, personnel and the environment and establish appropriate safeguards; and”.

5 MASTER’S RESPONSIBILITY AND AUTHORITY

3 The word “periodically” is added at the beginning of paragraph 5.1.5.

7 DEVELOPMENT OF PLANS FOR SHIPBOARD OPERATIONS

4 The existing section 7 is replaced by the following:

“7 SHIPBOARD OPERATIONS

The Company should establish procedures, plans and instructions, including checklists as appropriate, for key shipboard operations concerning the safety of the personnel, ship and protection of the environment. The various tasks should be defined and assigned to qualified personnel.”

8 EMERGENCY PREPAREDNESS

5 The existing paragraph 8.1 is replaced by the following:

“8.1 The Company should identify potential emergency shipboard situations, and establish procedures to respond to them.”

**9 REPORTS AND ANALYSIS OF NON-CONFORMITIES, ACCIDENTS
AND HAZARDOUS OCCURRENCES**

6 The existing paragraph 9.2 is replaced by the following:

“9.2 The Company should establish procedures for the implementation of corrective action, including measures intended to prevent recurrence.”

10 MAINTENANCE OF THE SHIP AND EQUIPMENT

7 In paragraph 10.3, the words “establish procedures in its safety management system to” are deleted.

12 COMPANY VERIFICATION, REVIEW AND EVALUATION

8 Paragraph 12.1 is replaced by the following:

“12.1 The Company should carry out internal safety audits on board and ashore at intervals not exceeding twelve months to verify whether safety and pollution-prevention activities comply with the safety management system. In exceptional circumstances, this interval may be exceeded by not more than three months.”

9 In paragraph 12.2, the words “efficiency of and, when needed, review” are replaced by the words “effectiveness of”.

13 CERTIFICATION AND PERIODICAL VERIFICATION

10 The following new paragraphs 13.12, 13.13 and 13.14 are added after the existing paragraph 13.11:

“13.12 When the renewal verification is completed after the expiry date of the existing Safety Management Certificate, the new Safety Management Certificate should be valid from the date of completion of the renewal verification to a date not exceeding five years from the date of expiry of the existing Safety Management Certificate.

13.13 If a renewal verification has been completed and a new Safety Management Certificate cannot be issued or placed on board the ship before the expiry date of the existing certificate, the Administration or organization recognized by the Administration may endorse the existing certificate and such a certificate should be accepted as valid for a further period which should not exceed five months from the expiry date.

13.14 If a ship at the time when a Safety Management Certificate expires is not in a port in which it is to be verified, the Administration may extend the period of validity of the Safety Management Certificate but this extension should be granted only for the purpose of allowing the ship to complete its voyage to the port in which it is to be verified, and then only in cases where it appears proper and reasonable to do so. No Safety Management Certificate should be extended for a period of longer than three months, and the ship to which an extension is granted should not, on its arrival in the port in which it is to be verified, be entitled by virtue of such extension to leave that port without having a new Safety Management Certificate. When the renewal verification is completed, the new Safety Management Certificate should be valid to a date not exceeding five years from the expiry date of the existing Safety Management Certificate before the extension was granted.”

14 INTERIM CERTIFICATION

11 In paragraph 14.4.3, the word “internal” is inserted after the words “planned the”.

Appendix

**Forms of the Document of Compliance, the Safety Management Certificate,
the Interim Document of Compliance and the Interim Safety Management Certificate**

SAFETY MANAGEMENT CERTIFICATE

12 The following new form is added after existing form of “ENDORSEMENT FOR INTERMEDIATE VERIFICATION AND ADDITIONAL VERIFICATION (IF REQUIRED)”:

“**Certificate No.**

**ENDORSEMENT WHERE THE RENEWAL VERIFICATION
HAS BEEN COMPLETED AND PART B 13.13 OF
THE ISM CODE APPLIES**

The ship complies with the relevant provisions of part B of the ISM Code, and the Certificate should, in accordance with part B 13.13 of the ISM Code, be accepted as valid until

Signed
(Signature of authorized official)
Place
Date

(Seal or stamp of the authority, as appropriate)

**ENDORSEMENT TO EXTEND THE VALIDITY OF THE
CERTIFICATE UNTIL REACHING THE PORT OF
VERIFICATION WHERE PART B 13.12 OF THE ISM CODE APPLIES
OR FOR A PERIOD OF GRACE WHERE PART B 13.14 OF
THE ISM CODE APPLIES**

This Certificate should, in accordance with part B 13.12 or part B 13.14 of the ISM Code, be accepted as valid until

Signed
(Signature of authorized official)
Place
Date

(Seal or stamp of the authority, as appropriate)”

ANNEX 9

**RESOLUTION MSC.274(85)
(adopted on 4 December 2008)**

**ADOPTION OF AMENDMENTS TO THE REVISED RECOMMENDATION ON
TESTING OF LIFE-SAVING APPLIANCES (RESOLUTION MSC.81(70))**

THE MARITIME SAFETY COMMITTEE,

RECALLING Article 28(b) of the Convention on the International Maritime Organization concerning the functions of the Committee,

RECALLING ALSO resolution A.689(17) on Testing of life-saving appliances, by which the Assembly, at its seventeenth session, adopted recommendations for test requirements for life-saving appliances,

RECALLING FURTHER that the Assembly, when adopting resolution A.689(17), authorized the Committee to keep the Recommendation on testing of life-saving appliances under review and to adopt, when appropriate, amendments thereto,

NOTING resolution MSC.81(70), by which, at its seventieth session, it adopted the Revised recommendation on testing of life-saving appliances, recognizing the need to introduce more precise provisions for the testing of life-saving appliances based on the requirements of the International Life-Saving Appliances (LSA) Code,

BEING DESIROUS to address increases in the size of mariners by increasing the assumed weight of persons in lifeboats and rescue boats, and to address potential injury by flexing of hulls and canopies of free-fall lifeboats during launch,

HAVING CONSIDERED, at its eighty-fifth session, amendments to the Revised recommendation on testing of life-saving appliances, proposed by the Sub-Committee on Ship Design and Equipment at its fifty-first session,

1. ADOPTS amendments to the Revised recommendation on testing of life-saving appliances (resolution MSC.81(70)), the text of which is set out in the Annex to the present resolution;
2. RECOMMENDS Governments to apply the annexed amendments when testing life-saving appliances.

ANNEX

**AMENDMENTS TO
THE REVISED RECOMMENDATION ON TESTING OF LIFE-SAVING APPLIANCES
(RESOLUTION MSC.81(70))**

**PART 1
PROTOTYPE TESTS FOR LIFE-SAVING APPLIANCES**

6.1 Definitions and general conditions

1 The existing paragraph 6.1.1 is replaced by the following:

“6.1.1 Except as specified otherwise, the mass of an average person as used herein should be taken to be 75 kg for a lifeboat intended for a passenger ship or 82.5 kg for a lifeboat intended for a cargo ship.”

6.3 Lifeboat overload test

2 In the first sentence of paragraph 6.3.2, after the word “persons”, the words “for the type of ship” are inserted.

3 The existing paragraph 6.3.9 is replaced by the following:

“6.3.9 This test should be considered successful if the lifeboat passes the operational test to the satisfaction of the Administration; no damage has been sustained that would affect the lifeboat’s efficient functioning; and any deflections of the hull or canopy as measured during the test would not cause injury to lifeboat occupants.”

6.7 Lifeboat seating space test

4 In the second sentence of paragraph 6.7.1, after the words “75 kg”, the words “for a lifeboat intended for a passenger ship or 82.5 kg for a lifeboat intended for a cargo ship,” are inserted.

7.1 Rigid rescue boats

5 In the second sentence of paragraph 7.1.3, the words “75 kg” are replaced by the words “82.5 kg”.

6 In the first sentence of paragraph 7.1.4, after the word “persons”, the words “, each weighing 82.5 kg,” are inserted.

7.2 Inflated rescue boats

7 In subparagraph .3 of paragraph 7.2.4, the words “75 kg” are replaced by the words “82.5 kg”.

8 In the first sentence of paragraph 7.2.11, after the word “persons”, the words “, each weighing 82.5 kg,” are inserted.

PART 2
PRODUCTION AND INSTALLATION TESTS

5.2 Davit-launched liferaft and inflated rescue boat test

9 In subparagraph .4 of paragraph 5.2, after the words “75 kg per person”, the words “for the liferaft and 82.5 kg per person for the rescue boat” are inserted.

6.1 Launching appliances using falls and winches

10 In the first sentence of paragraph 6.1.2, after the words “75 kg”, the words “or 82.5 kg, as applicable” are inserted.

11 In the first sentence of paragraph 6.1.5, after the words “75 kg”, the words “or 82.5 kg, as applicable” are inserted.

ANNEX 10**RESOLUTION MSC.275(85)
(adopted on 5 December 2008)****APPOINTMENT OF THE LRIT COORDINATOR**

THE MARITIME SAFETY COMMITTEE,

RECALLING Article 28(b) of the Convention on the International Maritime Organization concerning the functions of the Committee,

RECALLING ALSO the provisions of regulation V/19-1 (Long-range identification and tracking (LRIT) of ships) of the International Convention for the Safety of Life at Sea, 1974, as amended (the Convention) and, in particular, that, as from 31 December 2008, ships shall transmit, and Contracting Governments to the Convention (Contracting Governments) shall be able to receive, pursuant to the provisions of the regulation V/19-1 of the Convention (regulation), LRIT information,

BEARING IN MIND that regulation V/19-1 entered into force on 1 January 2008,

RECALLING FURTHER that regulation V/19-1.14 provides, *inter alia*, that the Committee shall determine the criteria, procedures and arrangements for the review and audit of the provision of LRIT information to Contracting Governments pursuant to the provisions of regulation V/19-1,

ALSO RECALLING that the Revised performance standards and functional requirements for the long-range identification and tracking of ships (the Revised performance standards) adopted by resolution MSC.263(84) provide in paragraph 14.1 that the LRIT Coordinator should be appointed by the Committee and in paragraph 14.4 that the functions of the LRIT Coordinator include, *inter alia*, the review of the performance of the LRIT system on an annual basis and the submission of related reports to the Committee,

NOTING that the International Mobile Satellite Organization has advised its willingness and readiness to assume the role of the LRIT Coordinator and to perform the functions and duties specified in paragraphs 14.2 to 14.5 of the Revised performance standards, subject to the provisions of paragraphs 14.6 to 14.7.3 of the Revised performance standards,

NOTING ALSO that the International Mobile Satellite Organization has also advised that it has put in place the necessary arrangements to the satisfaction of the Parties to the Convention on the International Mobile Satellite Organization which would enable it to assume the role, perform the functions and discharge the duties of the LRIT Coordinator,

DESIRING to put in place the necessary arrangements so as to ensure the performance review and audit of the LRIT system as from 31 December 2008, as well as for the performance of the other functions and duties of the LRIT Coordinator, as specified in paragraphs 14.2 to 14.5 of the Revised performance standards,

1. APPOINTS, subject to the provisions of paragraphs 14.7 to 14.7.3 of the Revised performance standards and within the framework of regulation V/19-1.14, the International Mobile Satellite Organization as the LRIT Coordinator;
2. REQUESTS the LRIT Coordinator to perform the functions and duties specified in paragraphs 14.1 to 14.5 of the Revised performance standards;
3. DECIDES that all LRIT Data Centres and the International LRIT Data Exchange should cooperate with the LRIT Coordinator when performing its functions and discharging its duties and to provide, in accordance with the provisions of paragraph 14.6 of the Revised performance standards, to the LRIT Coordinator all data and information it may request to this end;
4. DECIDES ALSO that all LRIT Data Centres and the International LRIT Data Exchange should discharge, in a timely manner, their financial obligations *vis-à-vis* the LRIT Coordinator in accordance with the arrangements they may agree with the LRIT Coordinator.

ANNEX 11**RESOLUTION MSC.276(85)
(adopted on 5 December 2008)****OPERATION OF THE INTERNATIONAL LRIT DATA EXCHANGE
ON AN INTERIM BASIS**

THE MARITIME SAFETY COMMITTEE,

RECALLING Article 28(b) of the Convention on the International Maritime Organization concerning the functions of the Committee,

RECALLING ALSO the provisions of regulation V/19-1 (Long-range identification and tracking (LRIT) of ships) of the International Convention for the Safety of Life at Sea, 1974, as amended (the Convention) and, in particular, that, as from 31 December 2008, ships shall transmit, and Contracting Governments to the Convention (Contracting Governments) shall be able to receive, pursuant to the provisions of the regulation V/19-1 of the Convention (regulation), LRIT information,

RECALLING FURTHER that the Revised performance standards and functional requirements for the long-range identification and tracking of ships (the Revised performance standards) adopted by resolution MSC.263(84) provide in paragraph 10.1 that an International LRIT Data Exchange, recognized by the Committee, should be established,

FURTHER RECALLING that, at its eighty-fourth session, it adopted resolution MSC.264(84) on the Establishment and operation of the International LRIT Data Exchange on an interim basis by the United States for a period of two years as from 1 January 2008, subject to a further review by the Committee, and agreed to discuss, at its eighty-fifth session, the arrangements for the establishment and operation of the International LRIT Data Exchange on a permanent basis,

NOTING that, until the establishment, testing and integration of all LRIT Data Centres into the LRIT system has been achieved, it would not be possible to either determine the volume of data the International LRIT Data Exchange would be required to handle; or define precisely the extent and volume of work the International LRIT Data Exchange would be required to perform; or adopt the final and definite version of the Technical specifications for the International LRIT Data Exchange, and as a result it would not be possible to invite, until the establishment of the LRIT system has been completed, realistic proposals for the establishment and operation of an International LRIT Data Exchange to replace the one provided by the United States on an interim basis,

NOTING ALSO that the arrangements for the establishment, testing and operation of an International LRIT Data Exchange on a permanent basis would need to be discussed and agreed upon with those to be selected to provide the International LRIT Data Exchange on a permanent basis, including how the various LRIT Data Centres and the LRIT Data Distribution Plan server would be integrated with the International LRIT Data Exchange so as to avoid any disruption of service and ensure the continuation of the functioning of the LRIT system,

NOTING WITH APPRECIATION the offer of the United States to continue to provide and operate the International LRIT Data Exchange on an interim basis for a period of two years after 31 December 2009 at no cost to either the Contracting Governments or the Organization,

MINDFUL of the key and pivotal role of the International LRIT Data Exchange in the LRIT system architecture,

DESIRING to put in place the necessary arrangements so as to ensure that the LRIT system continues to operate after 31 December 2009,

HAVING CONSIDERED, at its eighty-fifth session, the report on the satisfactory completion of testing of the International LRIT Data Exchange provided by the United States on an interim basis, during the prototype testing phase of the LRIT system,

1. EXPRESSES its thanks and appreciations to the United States for providing the International LRIT Data Exchange on an interim basis;
2. AGREES that the United States should continue to provide the International LRIT Data Exchange on an interim basis until 31 December 2011;
3. AGREES ALSO that, bearing in mind that the offer from the United States is only an interim arrangement and a permanent solution must be found for the International LRIT Data Exchange as soon as possible:
 - .1 at its eighty-sixth session, it would discuss the establishment and operation of the International LRIT Data Exchange on a permanent basis with a view to instructing the LRIT Coordinator in relation to the invitation of proposals for the establishment and operation of the International LRIT Data Exchange on a permanent basis; and
 - .2 at its eighty-seventh session, it would consider the proposals submitted to the LRIT Coordinator together with report of the LRIT Coordinator on the evaluation of the management, operational, technical and financial aspects of the proposals received and decide accordingly.

ANNEX 12

DRAFT AMENDMENTS TO SOLAS REGULATION II-1/3-5.2

CHAPTER II-1

**CONSTRUCTION – STRUCTURE, SUBDIVISION AND STABILITY, MACHINERY
AND ELECTRICAL INSTALLATIONS**

Regulation 3-5 – New installation of materials containing asbestos

In paragraph 2, a full stop is inserted after the word “prohibited” and the following text is deleted.

ANNEX 13

**RESOLUTION MSC.277(85)
(adopted on 28 November 2008)****CLARIFICATION OF THE TERM “BULK CARRIER” AND GUIDANCE FOR
APPLICATION OF REGULATIONS IN SOLAS TO SHIPS WHICH OCCASIONALLY
CARRY DRY CARGOES IN BULK AND ARE NOT DETERMINED AS BULK
CARRIERS IN ACCORDANCE WITH REGULATION XII/1.1 AND CHAPTER II-1**

THE MARITIME SAFETY COMMITTEE,

RECALLING Article 28(b) of the Convention on the International Maritime Organization concerning the functions of the Committee,

NOTING that the 1997 SOLAS Conference adopted chapter XII of the International Convention for the Safety of Life at Sea (SOLAS), 1974, concerning additional safety measures for bulk carriers,

NOTING ALSO that SOLAS chapter XII which entered into force on 1 July 1999 has since been revised by the adoption of resolutions MSC.170(79) and MSC.216(82),

NOTING FURTHER that definitions of the term “bulk carrier” exist in SOLAS chapters II-1, IX and XII,

DESIRING to ensure that all Contracting Governments to the 1974 SOLAS Convention implement SOLAS chapters II-1, III, IX, XI-1 and XII in a consistent and uniform manner,

RECOGNIZING, therefore, the need to establish, for that purpose, guidance on applications of, and interpretations to, the relevant provisions of SOLAS,

1. URGES Governments concerned to:

- .1 apply the provisions of this resolution to bulk carriers as defined in SOLAS and to ships as described in paragraph 1.5 of this resolution the keels of which are laid or which are at a similar stage of construction on or after 1 January 2009;
- .2 apply the provisions of this resolution to bulk carriers as defined in SOLAS and to ships which occasionally carry dry cargoes in bulk as described in paragraphs 1.3.2, 1.6 and 1.7 of this resolution the keels of which are laid or which are at a similar stage of construction on or after 1 July 2010;
- .3 interpret the term “*bulk carrier*” and its definition, as follows:
 - .1 “*primarily to carry dry cargo in bulk*” means primarily designed to carry dry cargoes in bulk and to transport cargoes which are carried, and loaded or discharged, in bulk, and which occupy the ship’s cargo spaces exclusively or predominantly; and

- .2 “includes such types as ore carriers and combination carriers” and “constructed generally with single deck, top-side tanks and hopper side tanks in cargo spaces” means that ships are not considered outside the definition of bulk carriers on the grounds that they are not ore or combination carriers or that they lack some or all of the specified constructional features;
- .4 note with respect to the above definitions that bulk carriers may carry cargoes which are not loaded or discharged in bulk, and remain bulk carriers while so doing;
- .5 avoid the inappropriate application of provisions of SOLAS chapters II-1, III, IX, XI-1 and XII to certain dedicated ship types by excluding from the scope of cargoes deemed, for the purpose of determining ship type, to be dry cargoes carried in bulk:
- .1 woodchips; and
- .2 cement, fly ash and sugar,
- provided that loading and unloading is not carried out by grabs heavier than 10 tonnes, power shovels and other means which frequently damage cargo hold structures;
- .6 permit ships other than those described in paragraphs 1.3 and 1.5 to occasionally carry dry cargoes in bulk, provided:
- .1 they are of double-side skin construction (where “double-side skin construction” is as defined in SOLAS chapter XII in relation to bulk carriers);
- .2 the freeboard assigned is type B without reduced freeboard; and
- .3 they comply with SOLAS regulations as applicable to bulk carriers to the extent indicated below:

SOLAS regulation
Regulation II-1/3-2.2 (Protective coatings of dedicated seawater ballast tanks in all types of ships and double-side skin spaces of bulk carriers) ¹
Regulations XII/6.2, 6.3 and 6.4 (Structural and other requirements for bulk carriers)
Regulation XII/10 (Solid bulk cargo density declaration)
Regulation XII/11 (Loading instrument)
Regulation XII/12 (Hold, ballast and dry space water ingress alarms)
Regulation XII/13 (Availability of pumping systems)

¹ Double-side skin void spaces of ships in accordance with paragraph 1.6 should be treated in the same manner as double-side skin spaces of bulk carriers.

- .7 permit ships of single-side skin construction of less than 100 m in length to occasionally carry dry cargoes in bulk, provided:
- .1 the freeboard assigned is type B without reduced freeboard; and
 - .2 they comply with SOLAS regulations as applicable to bulk carriers to the extent indicated below:

SOLAS regulation
Regulation XII/11 (Loading instrument)
Regulation XII/12 (Hold, ballast and dry space water ingress alarms)
Regulation XII/13 (Availability of pumping systems)

- .8 note that the ships referred to in paragraph 1.6 above are commonly arranged with 'tween decks or have discontinuities of the inner shape of the cargo hold area in the fore and aft region such as illustrated below:

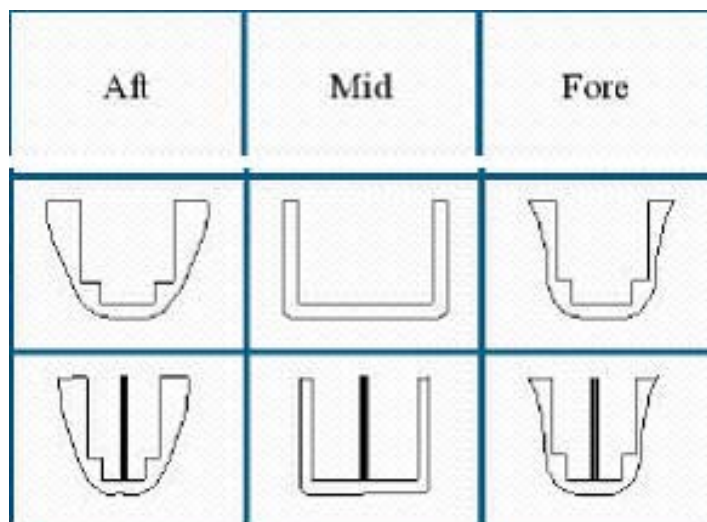

- .9 not consider a ship complying with paragraphs 1.6 and 1.7 to be a bulk carrier but, subject to compliance with the provisions in the relevant paragraphs, allow such ships to occasionally carry dry cargoes in bulk; and
 - .10 issue ships falling under the provisions of paragraph 1.5 and ships occasionally carrying dry cargoes in bulk with a statement attesting to the application of paragraph 1.5, 1.6 or 1.7 under the provisions of this resolution;
2. INVITES Governments concerned to bring the contents of this resolution to the attention of all parties concerned.

ANNEX 14

**NEW AND AMENDED TRAFFIC SEPARATION SCHEMES
AND ASSOCIATED ROUTEING MEASURES**

NEW TRAFFIC SEPARATION SCHEME “IN THE APPROACHES TO THE PORT OF THESSALONIKI”

(Reference chart: Hellenic Navy Hydrographic Service Chart No.255, edition May 1979 – as updated.

Note: The chart is based on European Datum (RE 50), however the positions mentioned below are in accordance with World Geodetic System 1984 Datum (WGS 84.)

Description of the traffic separation scheme

The routeing measures consist of a traffic separation scheme southwest of the Ak. Mikro Emvolon.

(a) A separation line connects the following geographical positions:

- | | | |
|-----|--------------|---------------|
| (4) | 40° 33'.39 N | 022° 51'.96 E |
| (5) | 40° 29'.94 N | 022° 46'.66 E |

(b) A separation zone connects the following geographical positions:

- | | | |
|-----|--------------|---------------|
| (5) | 40° 29'.94 N | 022° 46'.66 E |
| (6) | 40° 27'.24 N | 022° 46'.11 E |
| (7) | 40° 27'.24 N | 022° 45'.18 E |

(c) A traffic lane for northbound traffic is established between the separation line and the separation zone and a line connecting the following geographical positions:

- | | | |
|-----|--------------|---------------|
| (1) | 40° 27'.24 N | 022° 47'.21 E |
| (2) | 40° 29'.94 N | 022° 47'.46 E |
| (3) | 40° 33'.06 N | 022° 52'.36 E |

(d) A traffic lane for southbound traffic is established between the separation line and the separation zone and a line connecting the following geographical positions:

- | | | |
|------|--------------|---------------|
| (8) | 40° 27'.24 N | 022° 43'.86 E |
| (9) | 40° 30'.12 N | 022° 46'.11 E |
| (10) | 40° 33'.69 N | 022° 51'.61 E |

NEW TRAFFIC SEPARATION SCHEME THE “ÅLAND SEA”

Note: See “Åland Sea Deep-Water routes” in part C.

(Reference chart: Finnish chart number 953, Edition 2007 V and Swedish chart SE61 (INT1205) Edition 21/2-2008.

Note: This chart is based on World Geodetic System 1984 Datum (WGS 84).)

Description of the traffic separation scheme

North Åland Sea

Part I

(a) A separation line connecting the following geographical positions:

(1) 60° 29'.52 N 019° 00'.30 E (2) 60° 26'.94 N 019° 00'.36 E

(b) A traffic lane for southbound traffic is established between separation line and a line connecting the following geographical positions:

(3) 60° 29'.54 N 018° 56'.36 E (4) 60° 26'.89 N 18° 57'.05 E

(c) A traffic lane for northbound traffic is established between separation line and a line connecting the following geographical positions:

(5) 60° 26'.89 N 19° 03'.88 E (6) 60° 29'.51 N 019° 04'.56 E

Part II

(d) A separation zone 1.1 mile wide is centred upon the following geographical positions:

(7) 60° 11'.06 N 019° 03'.21 E (8) 60° 10'.09 N 019° 04'.80 E

(e) A traffic lane for the southbound traffic is established between the traffic separation zone and a line connecting the following geographical positions:

(9) 60° 09'.79 N 019° 00'.12 E (10) 60° 08'.83 N 019° 01'.71 E

(f) A traffic lane for the northbound traffic is established between the traffic separation zone and a line connecting the following geographical positions:

(11) 60° 11'.36 N 019° 07'.89 E (12) 60° 12'.33 N 019° 06'.30 E

South Åland Sea TSS

Part I

(g) A separation zone 1.1 mile wide is centred upon the following geographical positions:

(13) 59° 47'.28 N 019° 42'.44 E (14) 59° 46'.30 N 019° 44'.04 E

(h) A traffic lane for the southbound traffic is established between the traffic separation zone and a line connecting the following geographical positions:

(15) 59° 46'.01 N 019° 39'.39 E (16) 59° 45'.04 N 019° 40'.99 E

(i) A traffic lane for the northbound traffic is established between the traffic separation zone and a line connecting the following geographical positions:

(17) 59° 47'.57 N 019° 47'.10 E (18) 59° 48'.55 N 019° 45'.50 E

Part II

(j) A separation zone is bounded by a line connecting the following geographical positions:

(19) 59° 46'.03 N 019° 52'.85 E (21) 59° 45'.36 N 019° 58'.85 E
(20) 59° 45'.96 N 019° 58'.87 E (22) 59° 45'.42 N 019° 53'.83 E

(k) A traffic lane for the eastbound traffic is established between the separation zone, and a line connecting the following geographical positions:

(23) 59° 44'.24 N 019° 55'.74 E (24) 59° 44'.25 N 019° 58'.80 E

(l) A traffic lane for the westbound traffic is established between the separation zone, and a line connecting the following geographical positions:

(25) 59° 46'.96 N 019° 58'.92 E (26) 59° 47'.37 N 019° 50'.68 E

Part III

(m) A separation line connecting the following geographical positions:

(27) 59° 41'.22 N 020° 31'.98 E (28) 59° 43'.32 N 020° 28'.38 E
(29) 59° 44'.76 N 020° 23'.10 E

(n) A traffic lane for the eastbound traffic is established between the separation line, and the following geographical positions:

(30) 59° 44'.32 N 020° 19'.60 E (32) 59° 40'.56 N 020° 30'.34 E
(31) 59° 42'.87 N 020° 27'.57 E

- (o) A traffic lane for the westbound traffic is established between the separation line, and a line connecting the following geographical positions:

(33) 59° 41'.93 N 020° 33'.72 E (34) 59° 45'.68 N 020° 24'.51 E

Part IV

- (p) A separation line connecting the following geographical positions:

(35) 59° 42'.26 N 019° 51'.55 E (37) 59° 34'.26 N 020° 08'.40 E
(36) 59° 39'.70 N 019° 55'.19 E (38) 59° 30'.27 N 020° 08'.40 E

- (q) A separation line connecting the following geographical positions:

(39) 59° 30'.27 N 020° 06'.51 E (41) 59° 39'.44 N 019° 54'.13 E
(40) 59° 33'.75 N 020° 06'.51 E (42) 59° 41'.91 N 019° 50'.60 E

- (r) A traffic lane for the southbound traffic is established between the separation line above in paragraph (q) and line connecting the following geographical positions:

(43) 59° 40'.89 N 019° 47'.83 E (45) 59° 34'.89 N 019° 57'.20 E
(44) 59° 39'.57 N 019° 51'.58 E (46) 59° 30'.27 N 019° 54'.70 E

- (s) A traffic lane for the northbound traffic is established between the separation line above in paragraph (p) and following two lines connecting the following geographical positions:

Line 1

(47) 59° 30'.27 N 020° 15'.79 E (49) 59° 33'.90 N 020° 30'.13 E
(48) 59° 33'.90 N 020° 15'.79 E

Line 2

(50) 59° 37'.92 N 020° 30'.13 E (52) 59° 43'.59 N 019° 55'.17 E
(51) 59° 37'.92 N 020° 06'.72 E

- (t) The traffic is separated by natural obstructions (Svenska Björn lighthouse in geographical position 59°32'.86 N 020°01'.24 E and two shallow waters) inside the traffic lane for the southbound traffic by a line connecting the following geographical positions:

(53) 59° 30'.27 N 020° 01'.84 E (55) 59° 34'.15 N 019° 59'.68 E
(54) 59° 34'.15 N 020° 01'.84 E (56) 59° 30'.27 N 019° 59'.68 E

Precautionary areas

- (u) A precautionary area is bounded by a line connecting the following geographical positions:

(16) 59° 46'.01 N 019° 39'.39 E (23) 59° 44'.24 N 019° 55'.74 E
(17) 59° 47'.57 N 019° 47'.10 E (52) 59° 43'.59 N 019° 55'.17 E
(26) 59° 46'.96 N 019° 58'.92 E (43) 59° 40'.89 N 019° 47'.83 E

- (v) A circular precautionary area of radius of 6.5 nautical miles is centred upon the following geographical position:

(57) 59° 52'.03 N 019° 34'.66 E

NEW TRAFFIC SEPARATION SCHEME “IN LIVERPOOL BAY”

Note: See ATBA “In Liverpool Bay”

(Reference Chart: British Admiralty 1978, Edition 2007

Note: This chart is based on World Geodetic System 1984 Datum (WGS 84).)

Description of the traffic separation scheme

- (a) A separation zone (east of the “Douglas Oil Field” Platform), 1.0 nautical mile wide, is bounded by lines connecting the following geographical positions:

(1) 53° 32'.76 N 003° 32'.18 W
(2) 53° 32'.74 N 003° 33'.83 W
(3) 53° 31'.74 N 003° 33'.80 W
(4) 53° 31'.76 N 003° 32'.15 W

- (b) A separation zone (west of the “Douglas Oil Field” Platform), 1.0 nautical mile wide, is bounded by lines connecting the following geographical positions:

(5) 53° 32'.72 N 003° 35'.51 W
(6) 53° 32'.64 N 003° 41'.30 W
(7) 53° 31'.64 N 003° 41'.27 W
(8) 53° 31'.72 N 003° 35'.48 W

- (c) A traffic lane for eastbound traffic, 1.8 nautical miles wide, is established between the separation zones and a separation line connecting the following geographical positions:

(9) 53° 29'.96 N 003° 32'.10 W
(10) 53° 29'.84 N 003° 41'.21 W

- (d) A traffic lane for westbound traffic, 1.8 nautical miles wide, is established between the separation zones and a separation line connecting the following geographical positions:

(11) 53° 34'.56 N 003° 32'.24 W
(12) 53° 34'.44 N 003° 41'.36 W

AMENDMENTS TO THE EXISTING TRAFFIC SEPARATION SCHEME “IN THE APPROACH TO BOSTON, MASSACHUSETTS”

(Reference charts: United States 13009, 2007 edition; 13200, 2007 edition.

Note: These charts are based on North American 1983 Datum which is equivalent to WGS 1984 Datum (WGS 84).)

Description of the amended traffic separation scheme

(a) A separation zone, one mile wide, is centred upon the following geographical positions:

- | | | | | | |
|-----|--------------|---------------|-----|--------------|---------------|
| (1) | 42° 20'.73 N | 070° 39'.06 W | (3) | 40° 49'.25 N | 069° 00'.81 W |
| (2) | 42° 18'.28 N | 070° 01'.14 W | | | |

(b) A traffic lane for northbound traffic is established between the separation zone and a line connecting the following geographical positions:

- | | | | | | |
|-----|--------------|---------------|-----|--------------|---------------|
| (4) | 40° 50'.47 N | 068° 58'.67 W | (6) | 42° 22'.71 N | 070° 38'.62 W |
| (5) | 42° 20'.17 N | 069° 59'.40 W | | | |

(c) A traffic lane for southbound traffic is established between the separation zone and a line connecting the following geographical positions:

- | | | | | | |
|-----|--------------|---------------|-----|--------------|---------------|
| (7) | 42° 18'.82 N | 070° 40'.49 W | (9) | 40° 48'.03 N | 069° 02'.96 W |
| (8) | 42° 16'.39 N | 070° 02'.88 W | | | |

Precautionary areas

(a) A precautionary area of radius 6.17 nautical miles is centred upon the following geographical position (12) 42° 22'.71 N, 070° 46'.97 W.

(b) A precautionary area is bounded to the east by a circle of radius 15.5 miles, centred upon geographical position (13) 40° 35'.01 N, 068° 59'.96 W, intersected by the traffic separation schemes “In the approach to Boston, Massachusetts” and “Eastern Approach, Off Nantucket” (part II of the traffic separation scheme “Off New York”) at the following geographical positions:

- | | | | | | |
|-----|--------------|---------------|------|--------------|---------------|
| (4) | 40° 50'.47 N | 068° 58'.67 W | (11) | 40° 23'.75 N | 069° 13'.95 W |
|-----|--------------|---------------|------|--------------|---------------|

The precautionary area is bounded to the west by a line connecting the two traffic separation schemes between the following geographical positions:

- | | | | | | |
|-----|--------------|---------------|------|--------------|---------------|
| (9) | 40° 48'.03 N | 069° 02'.95 W | (10) | 40° 36'.76 N | 069° 15'.13 W |
|-----|--------------|---------------|------|--------------|---------------|

AMENDED TRAFFIC SEPARATION SCHEME “OFF LAND’S END, BETWEEN SEVEN STONES AND LONGSHIPS”

(Reference Charts: British Admiralty 1148 (published 06/2001), 2565 (published 06/2001)

Note: These charts are based on World Geodetic System 1984 Datum (WGS 84.)

Description of the amended traffic separation scheme

- (a) A separation zone, two miles wide, is bounded by lines connecting the following geographical positions:

(1)	49° 58'.02 N	005° 55'.76 W
(2)	50° 20'.03 N	005° 55'.76 W
(3)	50° 20'.03 N	005° 58'.88 W
(4)	49° 56'.52 N	005° 58'.88 W

- (b) A separation zone, one mile wide, is bounded by lines connecting the following geographical positions:

(5)	50° 00'.99 N	005° 49'.58 W
(6)	50° 20'.03 N	005° 49'.58 W
(7)	50° 20'.03 N	005° 51'.11 W
(8)	50° 00'.22 N	005° 51'.11 W

- (c) A separation zone, one mile wide, is bounded by lines connecting the following geographical positions:

(9)	49° 54'.29 N	006° 03'.56 W
(10)	50° 20'.03 N	006° 03'.56 W
(11)	50° 20'.03 N	006° 05'.06 W
(12)	49° 53'.54 N	006° 05'.06 W

- (d) A traffic lane for northbound traffic, three miles wide, is established between the separation zones described in paragraphs (a) and (b) above.

- (e) A traffic lane for southbound traffic, three miles wide, is established between the separation zones described in paragraphs (a) and (c) above.

Inshore Traffic Zones

- (f) The area between the eastern boundary of the TSS and Land’s End, and which lies between a line drawn from position (5) above in a direction of 078° to the coast and a line drawn from position (13) 50° 08'.00 N, 005° 49'.52 W, 005° 49'.58 W in a direction of 090° to the coast at Pendeen Point, is designated an inshore traffic zone.

- (g) The area between the western boundary of the TSS and the Isles of Scilly, and which lies between a line drawn from position (12) above in a direction of 270° to the islands and a line drawn from position (14) 50° 08'.00 N, 006° 05'.00 W, 50° 08'.00 N, 006° 05'.06 W in a direction of 225° to Round Island Lighthouse, is designated an inshore traffic zone.

AMENDED TRAFFIC SEPARATION SCHEME “IN THE APPROACHES TO THE RIVER HUMBER”

(Reference Charts: British Admiralty 109, (published 06/2006), 107, (published 09/2004)

Note: These charts are based on World Geodetic System 1984 Datum (WGS 84).)

Description of the Traffic Separation Scheme (TSS)

The proposed amendment to the Humber Traffic Separation Scheme (TSS) comprises:

- Extending the existing TSS by 18 nautical miles in a NNE direction to enhance the safety of navigation in the area between Mid New Sand Buoy and the pilot boarding area north of Humber Light Float.

Part I

Entrance to River Humber within Port Area

- (a) A precautionary area established by a line connecting the following geographical positions:

(1)	53° 34'.22 N	000° 06'.32 E	
(2)	53° 33'.54 N	000° 05'.70 E	
(3)	53° 33'.14 N	000° 06'.80 E	(Hobo)
(4)	53° 33'.92 N	000° 07'.43 E	(No. 3A Binks)
(1)	53° 34'.22 N	000° 06'.32 E	

- (b) A separation line connecting the following geographical positions:

(5)	53° 33'.54 N	000° 07'.13 E	(Delta)
(6)	53° 32'.73 N	000° 09'.65 E	(Charlie)

- (c) A traffic lane for inbound traffic established between the separation line specified in paragraph (b) above and a straight line connecting the following geographical positions:

(4)	53° 33'.92 N	000° 07'.43 E	(No. 3A Binks)
(7)	53° 33'.16 N	000° 10'.27 E	

- (d) A traffic lane for outbound traffic established between the separation line specified in paragraph (b) above and a straight line connecting the following geographical positions:

(3)	53° 33'.14 N	000° 06'.80 E	(Hobo)
(8)	53° 32'.34 N	000° 09'.11 E	(No. 2B)

- (e) A precautionary area established by a line connecting the following geographical positions:

(7)	53° 33'.16 N	000° 10'.27 E	
(8)	53° 32'.34 N	000° 09'.11 E	(No. 2B)
(9)	53° 32'.38 N	000° 11'.12 E	

- (10) 53° 33'.16 N 000° 11'.17 E
- (11) 53° 33'.07 N 000° 10'.63 E (No. 3 Chequer)
- (7) 53° 33'.16 N 000° 10'.27 E

(f) A separation line connecting the following geographical positions:

- (12) 53° 32'.67 N 000° 11'.15 E (Bravo)
- (13) 53° 32'.82 N 000° 13'.20 E (Alpha)

(g) A traffic lane for inbound traffic established between the separation line specified in paragraph (f) above and a straight line connecting the following geographical positions:

- (10) 53° 33'.16 N 000° 11'.17 E
- (14) 53° 33'.52 N 000° 13'.80 E

(h) A traffic lane for outbound traffic established between the separation line specified in paragraph (f) above and a straight line connecting the following geographical positions:

- (9) 53° 32'.38 N 000° 11'.12 E
- (15) 53° 32'.41 N 000° 12'.80 E

Part II

River Humber Approaches

(i) A precautionary area established by a line connecting the following geographical positions:

- (15) 53° 32'.41 N 000° 12'.80 E
- (16) 53° 32'.42 N 000° 13'.18 E (No. 2 Haile Sand)
- (17) 53° 30'.59 N 000° 16'.61 E
- (18) 53° 31'.90 N 000° 18'.29 E (Hotspur)
- (19) 53° 33'.57 N 000° 18'.29 E
- (20) 53° 34'.22 N 000° 17'.59 E (S. Haile)
- (21) 53° 34'.74 N 000° 16'.54 E (S. Binks)
- (22) 53° 33'.56 N 000° 14'.19 E (Spurn Light Float)
- (14) 53° 33'.52 N 000° 13'.80 E
- (15) 53° 32'.41 N 000° 12'.80 E

Eastern Approaches (Sea Reach)

(j) A separation line connecting the following geographical positions:

- (23) 53° 32'.72 N 000° 18'.29 E (Inner Sea Reach)
- (24) 53° 32'.72 N 000° 22'.95 E (Outer Sea Reach)

(k) A traffic lane for inbound traffic established between the separation line specified in paragraph (j) above and a straight line connecting the following geographical positions:

- (19) 53° 33'.57 N 000° 18'.29 E
- (25) 53° 33'.57 N 000° 22'.95 E

- (l) A traffic lane for outbound traffic established between the separation line specified in paragraph (j) above and a straight line connecting the following geographical positions:

(18) 53° 31'.90 N 000° 18'.29 E (Hotspur)
(26) 53° 31'.90 N 000° 22'.95 E

South-east Approaches (Rosse Reach)

- (m) A separation line connecting the following geographical positions:

(27) 53° 31'.24 N 000° 17'.44 E (Inner Rosse Reach)
(28) 53° 29'.89 N 000° 20'.79 E (Outer Rosse Reach)

- (n) A traffic lane for inbound traffic established between the separation line specified in paragraph (m) above and a straight line connecting the following geographical positions:

(18) 53° 31'.90 N 000° 18'.29 E (Hotspur)
(29) 53° 30'.56 N 000° 21'.57 E

- (o) A traffic lane for outbound traffic established between the separation line specified in paragraph (m) above and a straight line connecting the following geographical positions:

(17) 53° 30'.59 N 000° 16'.61 E
(30) 53° 29'.19 N 000° 19'.97 E

Part III

North-east Approaches (New Sand Hole)

- (p) A separation line connecting the following geographical positions:

(31) 53° 34'.48 N 000° 17'.06 E
(32) 53° 36'.99 N 000° 20'.64 E
(35) 53° 38'.52 N 000° 21'.87 E

- (q) A traffic lane for inbound traffic established between the separation line specified in paragraph (p) above and a straight line connecting the following geographical positions:

(21) 53° 34'.74 N 000° 16'.54 E (S. Binks)
(33) 53° 37'.27 N 000° 20'.10 E (Outer Binks)
(36) 53° 38'.70 N 000° 21'.24 E

- (r) A traffic lane for outbound traffic established between the separation line specified in paragraph (p) above and a straight line connecting the following geographical positions:

(20) 53° 34'.22 N 000° 17'.59 E (S. Haile)
(34) 53° 36'.72 N 000° 21'.20 E (Mid New Sand)
(37) 53° 38'.35 N 000° 22'.49 E (North New Sand)

AMENDED TRAFFIC SEPARATION SCHEME “AT HATTER BARN”

Note: See mandatory ship reporting system “In the Storebælt (Great Belt) Traffic Area (BELTREP)” in part G, section I.

(Reference chart: Danish chart no. 128, 9th edition, October 2007.

Note: The chart is based on World Geodetic System 1984 Datum (WGS 84).)

Description of the amended traffic separation scheme

(a) A separation line connects the following geographical positions:

(1) 55° 54'.67 N 010° 56'.40 E (2) 55° 50'.03 N 010° 49'.58 E

(b) A traffic lane of 675 metres wide at the narrowest part, for north-eastbound traffic, is established between the separation line and a separation zone connecting the following geographical positions:

(3) 55° 54'.75 N 010° 57'.87 E (7) 55° 47'.89 N 010° 50'.24 E
(4) 55° 53'.88 N 010° 56'.08 E (8) 55° 47'.89 N 010° 51'.64 E
(5) 55° 52'.42 N 010° 53'.93 E (9) 55° 53'.27 N 010° 59'.53 E
(6) 55° 49'.64 N 010° 50'.24 E (10) 55° 54'.75 N 011° 00'.00 E

(c) A traffic lane of 800 metres wide, for south-westbound traffic is established between the separation line and a separation line connecting the following geographical positions:

(11) 55° 54'.61 N 010° 55'.31 E (12) 55° 50'.54 N 010° 49'.34 E

Notes:

- 1 The minimum depth of water below mean sea level in the traffic separation scheme is 15 m.
- 2 Ships with a draught of more than 13 m should use the deep-water route which lies northwest of the traffic separation scheme.

ANNEX 15

ROUTEING MEASURES OTHER THAN TRAFFIC SEPARATION SCHEMES

ESTABLISHMENT OF A NEW RECOMMENDATORY SEASONAL AREA TO BE AVOIDED “IN THE GREAT SOUTH CHANNEL”, OFF THE EAST COAST OF THE UNITED STATES

(Reference charts: United States 13009, 2007 edition; 13200, 2007 edition. *Note:* These charts are based on North American 1983 Datum which is equivalent to WGS 1984 Datum.)

Description of the Area To Be Avoided

In order to significantly reduce ship strikes of the highly endangered North Atlantic right whale, ships of 300 gross tonnage and above – during the period of April 1st through July 31st – should avoid the area bounded by lines connecting the following geographical positions:

(1)	41° 44'.14 N	069° 34'.83 W
(2)	42° 10'.00 N	068° 31'.00 W
(3)	41° 24'.89 N	068° 31'.00 W
(4)	40° 50'.47 N	068° 58'.67 W

ESTABLISHMENT OF A NEW AREA TO BE AVOIDED AND TWO NEW MANDATORY NO ANCHORING AREAS IN THE VICINITY OF THE PROPOSED “EXCELERATE NORTHEAST GATEWAY ENERGY BRIDGE DEEPWATER PORT” IN THE ATLANTIC OCEAN

(Reference charts: United States 13009, 2007 edition; 13200, 2007 edition; 13246, 2006 edition; 13267, 2007 edition. *Note:* These charts are based on North American 1983 Datum which is equivalent to WGS 1984 Datum.)

Description of an Area To Be Avoided and mandatory no anchoring areas**Area To Be Avoided**

An area of approximately 2.86 nautical square miles contained within an oval of radius 1,250 metres vectored from the two centre positions for STL Buoys “A” and “B”, respectively, an Area to be Avoided for all ships except authorized ships is established in the area bounded as follows:

Starting at	(1)	42° 24'.29 N	070° 35'.27 W
A rhumb line to	(2)	42° 24'.59 N	070° 36'.76 W
Then an arc with a 1,250 m radius centred at	(3)	42° 23'.94 N	070° 37'.01 W
To a point	(4)	42° 23'.29 N	070° 37'.25 W
Then a rhumb line to	(5)	42° 22'.99 N	070° 35'.76 W
Then an arc with a 1,250 m radius centred at	(6)	42° 23'.64 N	070° 35'.52 W
Then to point	(1)	42° 24'.29 N	070° 35'.27 W

Mandatory no anchoring areas

Two areas contained within a circle of radius 1,000 metres centred upon the following geographical positions are established as mandatory no anchoring areas:

STL Buoy “A” – 42° 23′.64 N, 070° 35′.52 W
STL Buoy “B” – 42° 23′.94 N, 070° 37′.01 W

ESTABLISHMENT OF NEW DEEP-WATER ROUTES LEADING TO THE ÅLAND SEA

Note: See Traffic Separation Scheme for “The Åland Sea”.

(Reference chart: Finnish chart number 953, Edition 2007 V and Swedish chart SE61 (INT1205) Edition 21/2-2008.

Note: Those charts are based on World Geodetic System 1984 Datum (WGS 84).)

Description of the deep-water routes:

Inside the borders of the “North Åland Sea” TSS

A deep-water route forming part of the “North Åland Sea” TSS is established between the lines connecting the following geographical positions:

(i)	60° 29′.54 N	018° 56′.36 E	(iv)	60° 15′.26 N	019° 03′.50 E
(ii)	60° 18′.87 N	018° 59′.16 E	(v)	60° 18′.47 N	019° 01′.68 E
(iii)	60° 15′.28 N	018° 58′.08 E	(vi)	60° 29′.51 N	019° 04′.56 E

Inside the borders of the “South Åland Sea” TSS

A deep-water route forming part of the “South Åland Sea” TSS is established between the lines connecting the following geographical positions:

(vii)	59° 42′.26 N	019° 51′.55 E	(xi)	59° 30′.27 N	020° 06′.51 E
(viii)	59° 39′.70 N	019° 55′.19 E	(xii)	59° 33′.75 N	020° 06′.51 E
(ix)	59° 34′.26 N	020° 08′.40 E	(xiii)	59° 39′.44 N	019° 54′.13 E
(x)	59° 30′.27 N	020° 08′.40 E	(xiv)	59° 41′.91 N	019° 50′.60 E

ESTABLISHMENT OF A NEW TWO-WAY ROUTE LEADING TO THE ÅLAND SEA

(Reference chart: Finnish chart number 953, Edition 2007 V and Swedish chart SE61 (INT1205) Edition 21/2-2008.

Note: This chart is based on World Geodetic System 1984 Datum (WGS 84).)

Description of the two-way route in the South Åland Sea

A recommended two-way route is established in the area joining the following geographical positions:

(24)	59° 44'.25 N	019° 58'.80 E	(34)	59° 45'.68 N	020° 24'.51 E
(30)	59° 44'.32 N	020° 19'.60 E	(25)	59° 46'.96 N	019° 58'.92 E
(29)	59° 44'.76 N	020° 23'.10 E			

ESTABLISHMENT OF A NEW AREA TO BE AVOIDED “IN LIVERPOOL BAY”

Note: See Traffic Separation Scheme “In Liverpool Bay”.

(Reference Chart: British Admiralty 1978, Edition 2007.

Note: This chart is based on World Geodetic System 1984 Datum (WGS 84).)

Description of the Area To Be Avoided

In order to provide access to the Douglas Oil Field Platform an Area To Be Avoided (ATBA) of 1 nautical mile square centred on the Douglas Field Platform has been established within the Liverpool Bay Traffic Separation Scheme joining the following geographical positions:

(2)	53° 32'.74 N	003° 33'.83 W
(3)	53° 31'.74 N	003° 33'.80 W
(5)	53° 32'.72 N	003° 35'.51 W
(8)	53° 31'.72 N	003° 35'.48 W

Note: The ATBA should be avoided by all vessels, except in cases of emergency to avoid immediate danger, other than the following types (to the extent necessary to carry out their operations):

- (a) a vessel restricted in her ability to manoeuvre when engaged in the laying, servicing or picking up a navigation mark, submarine cable or pipeline;
- (b) offshore supply, support, maintenance and Emergency Response and Rescue vessels attending the Douglas Field Platform;
- (c) vessels engaged in hydrographic survey operations; and
- (d) vessels engaged in fishing.

ANNEX 16

**RESOLUTION MSC.278(85)
(adopted on 1 December 2008)**

**ADOPTION OF THE NEW MANDATORY SHIP REPORTING SYSTEM
“OFF THE COAST OF PORTUGAL – COPREP”**

THE MARITIME SAFETY COMMITTEE,

RECALLING Article 28(b) of the Convention on the International Maritime Organization concerning the functions of the Committee,

RECALLING ALSO regulation V/11 of the International Convention for the Safety of Life at Sea, 1974 (SOLAS Convention), in relation to the adoption of ship reporting systems by the Organization,

RECALLING FURTHER resolution A.858(20) resolving that the function of adopting ship reporting systems shall be performed by the Committee on behalf of the Organization,

TAKING INTO ACCOUNT the guidelines and criteria for ship reporting systems adopted by resolution MSC.43(64), as amended by resolutions MSC.111(73) and MSC.189(79),

HAVING CONSIDERED the recommendations of the Sub-Committee on Safety of Navigation at its fifty-fourth session,

1. ADOPTS, in accordance with SOLAS regulation V/11, the new mandatory ship reporting system “Off the coast of Portugal – COPREP”, set out in the Annex;
2. DECIDES that the mandatory ship reporting system, “COPREP”, will enter into force at 0000 hours UTC on 1 June 2009; and
3. REQUESTS the Secretary-General to bring this resolution and its Annex to the attention of the Member Governments and Contracting Governments to the 1974 SOLAS Convention.

ANNEX

**MANDATORY SHIP REPORTING SYSTEM
“OFF THE COAST OF PORTUGAL – COPREP”**

1 Categories of ships required to participate in the system

The following vessels are required to participate in the COPREP System:

- (a) all vessels of 300 gross tonnage or above;
- (b) all vessels carrying dangerous, hazardous and/or potentially polluting cargo;
- (c) all passenger vessels;
- (d) vessels engaged in towing or pushing where the combined length of the vessel and tow or pushed vessel is more than 100 m LOA;
- (e) fishing vessels with an LOA of 24 m or above; and
- (f) any other type of vessel is invited to voluntarily participate in the System.

2 Geographical coverage of the proposed systems and the number and edition of the reference chart used for delineation of the system

2.1 Geographical coverage of the proposed systems

The Ship Reporting System area is bounded by the shore and:

- (a) In the North: latitude 39° 45' N
- (b) In the West and South: By a line joining the following geographical positions:
 - (i) 39° 45' N
010° 14' W
 - (ii) 38° 41' N
010° 14' W
 - (iii) 36° 30' N
009° 35' W
 - (iv) 36° 15' N
008° 30' W
- (c) In the East: longitude 008° 30' W

2.2 Reference chart

The reference chart is “Cabo Finisterra a Casablanca”, Number 21101, Catalogue of Nautical Charts of the Portuguese Hydrographic Office, 4th impression – April 2002 (Note: This chart is based on WGS 84 Datum).

3 Reports and Procedures (Format and content of reports, authority to which reports should be sent)

3.1 Format

The format of information required in the COPREP reports is derived from the format given in resolution A.851(20) – General Principles for Ship Reporting Systems and Reporting Requirements, including guidelines for reporting incidents involving dangerous goods, harmful substances and/or marine pollutants.

3.2 Content

Vessels required to participate in the System shall make a report, with the short title “COPREP”, to Roca Control and shall contain the following information, which is considered essential for the purpose of the System:

DESIGNATOR	INFORMATION REQUIRED
A	Ship's name and callsign IMO identification or MMSI number on request
C	Position (Latitude – Longitude), or
D	Distance and bearing from a landmark
E	True course in a three(3)-digit group
F	Speed in knots
G	Last port of call
H	Time (UTC) and point of entry in the reporting sector
I	Next port of call and ETA
P	Hazardous cargo, IMO class or UN number and quantity
Q or R	Breakdown, damage and/or deficiencies affecting, the structure, cargo or equipment of the vessel or any other circumstances affecting normal navigation, in accordance with the provisions of the SOLAS and MARPOL Conventions
W	Total number of persons on board (when requested)
X	Miscellaneous remarks (when requested)

Any vessel may elect, for reasons of commercial confidentiality, to communicate the information regarding cargo (designator P of the report), by non-verbal means prior to entering the System.

3.3 Time and geographical position for submitting reports

3.3.1 Ships must submit a report:

- (a) on entering the reporting area as defined in paragraph 2.1; or
- (b) immediately after leaving a port, terminal or anchorage situated in the reporting area; or

- (c) when deviating from the route leading to the originally declared destination, port, terminal, anchorage or position “for orders” given on entry into the reporting area; or
- (d) when it is necessary to deviate from the planned route owing to weather conditions, damaged equipment or a change in navigational status; or
- (e) when something is detected that could affect safety of navigation in the area; or
- (f) on finally leaving the reporting area; or
- (g) when requested by COPREP operator.

3.3.2 Ships who have submitted a voluntary report with the same designator letters prior to entering the reporting area are only required to submit a mandatory report:

- (a) if there are any changes in previously submitted information;
- (b) with designator letters “A” and “H” when entering the reporting area.

3.4 *Shore-based authority*

The shore-based authority for COPREP mandatory ship reporting system, to which these reports should be sent, is ROCA CONTROL (identified in paragraph 7).

4 Information to be provided to the participating ship and the procedures to be followed:

ROCA CONTROL is an information service. Ships are provided with information broadcasts on weather, hazards affecting the safety of navigation and other traffic in the area.

These broadcasts include:

- (a) traffic information;
- (b) hampered vessels such as vessels not under command or vessels restricted in their ability to manoeuvre;
- (c) adverse weather conditions;
- (d) weather warnings and forecast;
- (e) displaced or defective aids to navigation;
- (f) radar assistance; and
- (g) information on local harbours.

Information is broadcast on request or whenever necessary. Information broadcasts on ROCA CONTROL VHF main channel are preceded by an announcement on VHF channel 16. Information may be more frequent on occasions of adverse weather conditions, reduced visibility and imminent incident or accident.

The VTS centre is linked to MRCC LISBON and pollution control authorities in order to allow a prompt response to any emerging distress or urgent situation.

5 Communication requirements for the system, including frequencies on which reports should be transmitted and information to be reported:

The communications required for the COPREP are as follows:

- (a) The call to the shore-based authority shall be made on the VHF channel assigned to Vessel Traffic Service in the Portuguese Coast, or by the other available means based on the following contact information:

CALL:	Roca Control
TELEPHONE:	351-214464830
FAX:	351-214464839
E-mail:	oper.vts@imarpor.pt
VHF CHANNELS	
Primary channels:	22 and 79 Secondary channel: 69
CALL SIGN:	CSG229
MMSI:	00 263 3030

- (b) The language used for communication shall be Portuguese or English, using the IMO Standard Marine Communications Phrases, where necessary.
- (c) Information of commercial confidentiality may be transmitted by non-verbal means.

6 Rules and regulations in force in the area of the proposed system

Portugal has taken appropriate action to implement international conventions to which it is a party including, where appropriate, adopting domestic legislation and promulgating regulations through domestic law. Relevant laws in force include domestic legislation and international regulations such as:

- (a) International Regulations for Preventing Collisions at Sea (COLREGs), 1972, as amended;
- (b) International Convention for the Safety of Life at Sea (SOLAS), 1974, as amended;
- (c) International Convention on the Prevention of Pollution from Ships (MARPOL 73/78); and
- (d) Directive 2002/59/CE.

7 Shore-based facilities and personnel qualifications and training required to support the operation of the proposed system

7.1 Shore-based facilities

ROCA CONTROL maintains a continuous 24-hour watch over the COPREP area. The facilities of the Roca Control are the following:

- (a) 8 Coastal Radars:
 - (i) Long-range SCANTER primary radars
 - (ii) Focus of long distance sea side coverage
 - (iii) Special high gain 21" antennas
 - (iv) Surveillance of all the continental Portuguese Coast
 - (v) Video from selected radar and combined radar data available to main centre's VTS operator;

- (b) 8 Harbour Radars:
 - (i) Short range primary radars (for 3 of those)
 - (ii) Surveillance of the harbours approach area (for 5 of those)
 - (iii) Video from selected radar and combined radar data available to main centre's VTS operator;

- (c) 11 AIS Sites:
 - (i) Automatic identification of ships:
 - IMO standards
 - 3 types of information: ship static, dynamic and voyage
 - (ii) Based on GPS positioning
 - (iii) AIS position data merged with radar data at operator display (TDS)
 - (iv) Ship identification correlated with National Maritime Ship Database;

- (d) 11 Voice Radio Communication Sites:
 - (i) VHF voice radio communication with ships and aeronautical emergency channel
 - (ii) Complete coverage of the continental Portuguese Coast
 - (iii) VTS operators are able to communicate within the coverage area
 - (iv) Telephone and electronic communication between harbours and VTS control centres;
- (e) 11 VHF Direction Finder Sites:
 - (i) Azimuthing of radio communication
 - (ii) Complete coverage of the continental Portuguese Coast
 - (iii) Data from all sites available for the VTS operators
 - (iv) RDF data is present on operator displays (TDS);
- (f) 6 Meteorological Sites with:
 - (i) Anemometer, Thermometer, Barometer, Hygrometer, Rainfall indicator, Visibility sensors
 - (ii) Meteorological data of all sites will be presented to the VTS operators.

7.2 *Personnel qualifications and training*

The training given to ROCA CONTROL staff complies with the national and international recommendations and include a general study of navigational safety measures and the relevant national and international (IMO) provisions/requirements to support the operation of the proposed system.

8 Alternative procedures if the communication facilities of the shore-based authority fail

The system is designed to avoid, as far as possible, any irretrievable breakdown of equipment which would hinder the functioning of the services normally provided by ROCA CONTROL.

The most important items of equipment and power sources are duplicated and the facilities are provided with emergency generating sets as well as with Uninterruptible Power Supply (UPS) units. A maintenance team is available 24 hours a day to attend to any breakdown.

The system is also designed in such a manner that if one station fails, the adjacent station can provide the necessary coverage.

9 Actions to take in the event of emergency or ship's non-compliance with the system requirements

The main objectives of the system are to improve ships' safety in and off the Portuguese coast waters, support the organization of search and rescue and protect and improve the marine environment in the coast, developing the actions as fast and effective as possible if an emergency is reported or a report from a ship fails to appear, and it is impossible to establish communication with the ship. All means will be used to obtain the full participation of ships required to submit reports.

The mandatory ship reporting system COPREP is for the exchange of information only and does not provide any additional authority for mandating changes in the ship's operations. This reporting system will be implemented consistent with UNCLOS, SOLAS and other relevant international instruments so that the reporting system will not constitute a basis for preventing the passage of a ship through the reporting area.

Infringements of these regulations shall be punishable under Portuguese law, or reported to the ship's flag State in accordance with IMO resolution A.432(XI) – Compliance with the Convention on the International Regulations for Preventing Collisions at Sea, 1972, as amended.

ANNEX 17

**RESOLUTION MSC.279(85)
(adopted on 1 December 2008)**

**ADOPTION OF AMENDMENTS TO THE EXISTING SHIP REPORTING SYSTEM
FOR THE “PAPAHĀNAUMOKUĀKEA MARINE NATIONAL MONUMENT”,
PARTICULARLY SENSITIVE SEA AREA, “CORAL SHIPREP”**

THE MARITIME SAFETY COMMITTEE,

RECALLING Article 28(b) of the Convention on the International Maritime Organization concerning the functions of the Committee,

RECALLING ALSO regulation V/11 of the International Convention for the Safety of Life at Sea, 1974 (SOLAS Convention), in relation to the adoption of ship reporting systems by the Organization,

RECALLING FURTHER resolution A.858(20) resolving that the function of adopting ship reporting systems shall be performed by the Committee on behalf of the Organization,

TAKING INTO ACCOUNT the guidelines and criteria for ship reporting systems adopted by resolution MSC.43(64), as amended by resolutions MSC.111(73) and MSC.189(79),

HAVING CONSIDERED the recommendations of the Sub-Committee on Safety of Navigation at its fifty-fourth session,

1. ADOPTS, in accordance with SOLAS regulation V/11, the amendments to the existing ship reporting system for the “Papahānaumokuākea Marine National Monument”, Particularly Sensitive Sea Area, “CORAL SHIPREP”, as set out in the Annex;
2. DECIDES that the said amendments to the existing ship reporting system “CORAL SHIPREP” will enter into force at 0000 hours UTC on 1 June 2009; and
3. REQUESTS the Secretary-General to bring this resolution and its Annex to the attention of the Member Governments and Contracting Governments to the 1974 SOLAS Convention.

ANNEX

**AMENDMENTS TO THE EXISTING SHIP REPORTING SYSTEM FOR
THE “PAPAHĀNAUMOKUĀKEA MARINE NATIONAL MONUMENT”,
PARTICULARLY SENSITIVE SEA AREA, “CORAL SHIPREP”**

- 1 Amend the Annex to resolution MSC.248(83) as follows:

The reporting address given in paragraphs 3.4.1, 5.3 and 5.4 is replaced by the following:

[“nwhi.notifications@noaa.gov”](mailto:nwhi.notifications@noaa.gov).

- 2 Amend the appendix to resolution MSC.248(83), as follows:

Appendix

Geographical coordinates

Ship reporting system

(Reference charts: United States 19016, 2007 edition; 19019, 2007 edition; 19022, 2007 edition. These charts are based on World Geodetic Survey (WGS) 1984 and astronomic Datum.)

1 Outer Boundary

The outer boundary of the “CORALSHIPREP” reporting area consists of lines connecting the following geographical positions:

Starting at	(1)	29° 24′.21 N,	178° 06′.45 W
A rhumb line to	(2)	29° 12′.16 N,	177° 04′.25 W
Then a rhumb line to	(3)	28° 43′.78 N,	175° 13′.76 W
Then a rhumb line to	(4)	27° 00′.28 N,	173° 25′.37 W
Then a rhumb line to	(5)	26° 44′.85 N,	171° 28′.22 W
Then a rhumb line to	(6)	26° 23′.95 N,	170° 20′.25 W
Then a rhumb line to	(7)	25° 56′.49 N,	167° 32′.03 W
Then a rhumb line to	(8)	24° 50′.23 N,	165° 58′.56 W
Then a rhumb line to	(9)	24° 02′.61 N,	161° 42′.30 W
Then an arc with a 60.25 nm radius centred at	(21)	23° 03′.61 N,	161° 55′.22 W
To a point	(10)	22° 04′.59 N,	162° 08′.14 W
Then a rhumb line to	(11)	22° 35′.32 N,	164° 53′.46 W
Then a rhumb line to	(12)	22° 47′.86 N,	166° 40′.44 W
Then a rhumb line to	(13)	24° 03′.30 N,	168° 27′.53 W
Then a rhumb line to	(14)	24° 26′.59 N,	170° 50′.37 W
Then a rhumb line to	(15)	24° 46′.49 N,	171° 52′.87 W
Then a rhumb line to	(16)	25° 07′.23 N,	174° 30′.23 W
Then a rhumb line to	(17)	27° 05′.50 N,	176° 35′.40 W
Then a rhumb line to	(18)	27° 15′.11 N,	177° 35′.26 W
Then a rhumb line to	(19)	27° 26′.10 N,	178° 32′.23 W
Then an arc with a 60.17 nm radius centred at	(20)	28° 25′.23 N,	178° 19′.51 W
Then to point	(1)	29° 24′.21 N,	178° 06′.45 W

2 Inner Boundary

The inner boundaries of the “CORAL SHIPREP” SRS reporting area are coterminous with the outer boundaries of the IMO-adopted Areas To Be Avoided “In the Region of the Papahānaumokuākea Marine National Monument”, which consist of the following:

1 Those areas contained within circles of radius of 50 nautical miles centred upon the following geographical positions:

- | | | | |
|----|---------------|---------------|----------------------------|
| a. | 28° 25'.18 N, | 178° 19'.75 W | (Kure Atoll) |
| b. | 28° 14'.20 N, | 177° 22'.10 W | (Midway Atoll) |
| c. | 27° 50'.62 N, | 175° 50'.53 W | (Pearl and Hermes Atoll) |
| d. | 26° 03'.82 N, | 173° 58'.00 W | (Lisianski Island) |
| e. | 25° 46'.18 N, | 171° 43'.95 W | (Laysan Island) |
| f. | 25° 25'.45 N, | 170° 35'.32 W | (Maro Reef) |
| g. | 25° 19'.50 N, | 170° 00'.88 W | (Maro Reef and Raita Bank) |
| h. | 25° 00'.00 N, | 167° 59'.92 W | (Gardner Pinnacles) |
| i. | 23° 45'.52 N, | 166° 14'.62 W | (French Frigate Shoals) |
| j. | 23° 34'.60 N, | 164° 42'.02 W | (Necker Island) |
| k. | 23° 03'.38 N, | 161° 55'.32 W | (Nihoa Island). |

2 Those areas contained between the following geographical coordinates:

		Begin Coordinates		End Coordinates	
		Latitude	Longitude	Latitude	Longitude
Area 1	Lisianski Island (N) ---> Laysan Island	26° 53'.22 N	173° 49'.64 W	26° 35'.58 N	171° 35'.60 W
	Lisianski Island (S) ---> Laysan Island	25° 14'.42 N	174° 06'.36 W	24° 57'.63 N	171° 57'.07 W
Area 2	Gardner Pinnacles (N) ---> French Frigate Shoals	25° 38'.90 N	167° 25'.31 W	24° 24'.80 N	165° 40'.89 W
	Gardner Pinnacles (S) ---> French Frigate Shoals	24° 14'.27 N	168° 22'.13 W	23° 05'.84 N	166° 47'.81 W

ANNEX 18**RESOLUTION MSC.280(85)
(adopted on 1 December 2008)****ADOPTION OF AMENDMENTS TO THE GENERAL PROVISIONS
ON SHIPS' ROUTEING
(RESOLUTION A.572(14), AS AMENDED)**

THE MARITIME SAFETY COMMITTEE,

RECALLING Article 28(b) of the Convention on the International Maritime Organization concerning the functions of the Committee,

RECOGNIZING the importance that the routing measures boundary symbology and charting of archipelagic sea lanes used in the General Provisions on Ships' Routeing should correctly reflect those adopted by IHO,

TAKING INTO ACCOUNT the decision of the Sub-Committee on Safety of Navigation at its fifty-fourth session to align the routing measures boundary symbology and charting of archipelagic sea lanes in Annexes 1 and 2 of General Provisions on Ships' Routeing,

HAVING CONSIDERED, at its eighty-fifth session, the text of proposed amendments to Annexes 1 and 2 of the General Provisions on Ships' Routeing (resolution A.572(14), as amended), to align them with the specifications for routing measures boundary symbology and charting of archipelagic sea lanes adopted by IHO,

1. **ADOPTS** the amendments to the General Provisions on Ships' Routeing (resolution A.527(14), as amended), to align them with the specifications for routing measures boundary symbology and charting of archipelagic sea lanes adopted by IHO, the text of which is set out in the Annex to the present resolution;
2. **DETERMINES** that amendments to the General Provisions on Ships' Routeing including amendments to the General Provisions for the adoption, designation and substitution of archipelagic sea lanes shall be adopted, brought into force and shall take effect in accordance with the provisions of resolution A.572(14), as amended;
3. **INVITES** Governments intending to submit proposals for the adoption of ships' routing systems including, designation and substitution of archipelagic sea lanes to take account of the annexed General Provisions;
4. **REQUESTS** the Secretary-General to bring this resolution and its Annex to the attention of all Contracting Governments to the SOLAS Convention and to Members of the Organization which are not Contracting Governments to the Convention.

ANNEX

**AMENDMENTS TO THE GENERAL PROVISIONS ON SHIPS' ROUTEING
 (RESOLUTION A.572(14), AS AMENDED)**

1 Annex 1 – General Provisions on Ships' Routeing

1.1 Amend section 9.4, as follows:

Section 9.4 Boundary symbols in detail

5	Inshore traffic zone (ends) ----- Open sea	----- or no symbol (limits undefined)
15	Two-way route ----- All other areas	----- Same rules as for deep-water route

2 Annex 2 – General Provisions for the Adoption, Designation and Substitution of Archipelagic Sea Lanes.

2.1 Amend section 7.6 as follows:

7.6 Symbol for outer limits of archipelagic sea lanes

Unless otherwise specified, symbols are printed on charts in colour, usually magenta.

Description	Symbol	Note
1 Outer limit of archipelagic sea lane, including where 10% rule applies		1

Note:

1 The solid triangle indicator points into the archipelagic sea lane. The full outer limit of archipelagic sea lane may be charted where it is considered appropriate.

2.2 Amend section 7.7 as follows:

Replace the existing symbol for outer limit of ASL with the following symbol:

2	Outer limit	
---	-------------	---

ANNEX 19

DRAFT AMENDMENTS TO SOLAS REGULATION V/19

CHAPTER V
SAFETY OF NAVIGATION**Regulation 19 – Carriage requirements for shipborne navigational systems and equipment**

1 Subparagraph .4 of paragraph 2.1 is replaced by the following:

“4 nautical charts and nautical publications to plan and display the ship’s route for the intended voyage and to plot and monitor positions throughout the voyage. An electronic chart display and information system (ECDIS) is also accepted as meeting the chart carriage requirements of this subparagraph. Ships to which paragraph [2.10] applies shall comply with the carriage requirements for ECDIS detailed therein;”

2 In paragraph 2.2, the new subparagraphs .3 and .4 are added after the existing subparagraph .2 as follows:

“3 a bridge navigational watch alarm system (BNWAS) complying with standards not inferior to those adopted by the Organization*, as follows:

- .1 ships of 150 gross tonnage and upwards and passenger ships irrespective of size constructed on or after [1 July 2011];
- .2 passenger ships irrespective of size constructed before [1 July 2011], not later than the first survey** after [1 July 2012];
- .3 ships of 3,000 gross tonnage and upwards constructed before [1 July 2011], not later than the first survey** after [1 July 2012];
- .4 ships of 500 gross tonnage and upwards but less than 3,000 gross tonnage constructed before [1 July 2011], not later than the first survey** after [1 July 2013]; and
- .5 ships of 150 gross tonnage and upwards but less than 500 gross tonnage constructed before [1 July 2011], not later than the first survey** after [1 July 2014].

The bridge navigational watch alarm system shall be in operation whenever the ship is underway at sea;

- .4 bridge navigational watch alarm system (BNWAS) installed prior to 1 July 2011 may subsequently be exempted from full compliance with such standards at the discretion of the Administration.”

* Refer to the Performance standards for a bridge navigational watch alarm system (BNWAS), adopted by the Organization by resolution MSC.128(75).

** Refer to the Unified interpretation of the term “first survey” referred to in SOLAS regulations (MSC.1/Circ.1290).

3 The following new paragraphs 2.10 and 2.11 are added after the existing paragraph 2.9:

“2.10 Ships engaged on international voyages shall be fitted with an Electronic Chart Display and Information System (ECDIS) as follows:

- .1 passenger ships of 500 gross tonnage and upwards constructed on or after [1 July 2012];
- .2 tankers of 3,000 gross tonnage and upwards constructed on or after [1 July 2012];
- .3 cargo ships, other than tankers, of 10,000 gross tonnage and upwards constructed on or after [1 July 2013];
- .4 cargo ships, other than tankers, of 3,000 gross tonnage and upwards but less than 10,000 gross tonnage constructed on or after [1 July 2014];
- .5 passenger ships of 500 gross tonnage and upwards constructed before [1 July 2012], not later than the first survey* on or after [1 July 2014];
- .6 tankers of 3,000 gross tonnage and upwards constructed before [1 July 2012], not later than the first survey* on or after [1 July 2015];
- .7 cargo ships, other than tankers, of 50,000 gross tonnage and upwards constructed before [1 July 2013], not later than the first survey* on or after [1 July 2016];
- .8 cargo ships, other than tankers, of 20,000 gross tonnage and upwards but less than 50,000 gross tonnage constructed before [1 July 2013], not later than the first survey* on or after [1 July 2017]; and
- .9 cargo ships, other than tankers, of 10,000 gross tonnage and upwards but less than 20,000 gross tonnage constructed before [1 July 2013], not later than the first survey* on or after [1 July 2018].

2.11 Administration may exempt ships from the application of the requirements of paragraph 2.10 when such ships will be taken permanently out of service within two years after the implementation date specified in subparagraphs .5 to .9 of paragraph 2.10.”

* Refer to the Unified interpretation of the term “first survey” referred to in SOLAS regulations (MSC.1/Circ.1290).

ANNEX 20

STRATEGY FOR THE DEVELOPMENT AND IMPLEMENTATION OF E-NAVIGATION

1 DEFINITION AND SCOPE

1.1 E-navigation is the harmonized collection, integration, exchange, presentation and analysis of marine information on board and ashore by electronic means to enhance berth to berth navigation and related services for safety and security at sea and protection of the marine environment.

1.2 E-navigation is intended to meet present and future user needs through harmonization of marine navigation systems and supporting shore services.

2 THE NEED FOR E-NAVIGATION

2.1 There is a clear and compelling need to equip shipboard users and those ashore responsible for the safety of shipping with modern, proven tools that are optimized for good decision making in order to make maritime navigation and communications more reliable and user friendly. The overall goal is to improve safety of navigation and to reduce errors. However, if current technological advances continue without proper co-ordination there is a risk that the future development of marine navigation systems will be hampered through a lack of standardization on board and ashore, incompatibility between vessels and an increased and unnecessary level of complexity.

2.2 The Strategic Plan for the Organization for the period 2008-2013* recognizes that technological developments have created new opportunities, but may also have negative consequences. New opportunities therefore exist to further develop various IMO initiatives, from safety and security to environmental protection. Developments in communications and information technology will provide opportunities to develop knowledge management so as to increase transparency and accessibility to information. The challenge for IMO is to:

- .1 ensure that the technological developments adopted are conducive to enhancing maritime safety, security and protection of the environment, and take into account the need for their global application;
- .2 ensure the proper application of information technology within the Organization and to provide enhanced access to that information for the shipping industry and others; and
- .3 ensure that new equipment for use on board ships is designed and manufactured with the needs, skills and abilities of all users in mind.

* Resolution A.989(25).

3 THE CASE FOR E-NAVIGATION

3.1 Rising trends of marine accidents both in terms of numbers and costs are mainly associated with collisions and groundings. There are numerous examples of collisions and groundings that might have been avoided had there been suitable input to the navigation decision-making process.

3.2 Research indicates that around 60% of collisions and groundings are caused by direct human error. Despite advances in bridge resource management training, it seems that the majority of watchkeeping officers make critical decisions for navigation and collision avoidance in isolation, due to a general reduction in manning.

3.3 In human reliability analysis terms, the presence of someone checking the decision-making process improves reliability by a factor of 10. If e-navigation could assist in improving this aspect, both by well-designed onboard systems and closer cooperation with vessel traffic management (VTM) instruments and systems, risk of collisions and grounding and their inherent liabilities could be dramatically reduced.

3.4 However, although e-navigation may be able to improve the situations described above, there is also a need to recognize the role of the practice of good seamanship, the provision of suitable training and the use of procedures.

4 VISION OF E-NAVIGATION

4.1 A vision of e-navigation is embedded in the following general expectations for the onboard, ashore and communications elements:

.1 On board

Navigation systems that benefit from the integration of own ship sensors, supporting information, a standard user interface, and a comprehensive system for managing guard zones and alerts. Core elements of such a system will include, actively engaging the mariner in the process of navigation to carry out his/her duties in a most efficient manner, while preventing distraction and overburdening;

.2 Ashore

The management of vessel traffic and related services from ashore enhanced through better provision, coordination, and exchange of comprehensive data in formats that will be more easily understood and utilized by shore-based operators in support of vessel safety and efficiency; and

.3 Communications

An infrastructure providing authorized seamless information transfer on board ship, between ships, between ship and shore and between shore authorities and other parties with many related benefits.

5 CORE OBJECTIVES OF E-NAVIGATION

5.1 The core objectives of the e-navigation concept are to:

- .1 facilitate safe and secure navigation of vessels having regard to hydrographic, meteorological and navigational information and risks;
- .2 facilitate vessel traffic observation and management from shore/coastal facilities, where appropriate;
- .3 facilitate communications, including data exchange, among ship to ship, ship to shore, shore to ship, shore to shore and other users;
- .4 provide opportunities for improving the efficiency of transport and logistics;
- .5 support the effective operation of contingency response, and search and rescue services;
- .6 demonstrate defined levels of accuracy, integrity and continuity appropriate to a safety-critical system;
- .7 integrate and present information on board and ashore through a human-machine interface which maximizes navigational safety benefits and minimizes any risks of confusion or misinterpretation on the part of the user;
- .8 integrate and present information onboard and ashore to manage the workload of the users, while also motivating and engaging the user and supporting decision-making;
- .9 incorporate training and familiarization requirements for the users throughout the development and implementation process;
- .10 facilitate global coverage, consistent standards and arrangements, and mutual compatibility and interoperability of equipment, systems, symbology and operational procedures, so as to avoid potential conflicts between users; and
- .11 support scalability, to facilitate use by all potential maritime users.

6 BENEFITS OF E-NAVIGATION

6.1 The main broad benefits of e-navigation are expected to be:

- .1 improved safety, through promotion of standards in safe navigation supported by:
 - .1 improved decision support enabling the mariner and competent authorities ashore to select relevant unambiguous information pertinent to the prevailing circumstances;
 - .2 a reduction in human error through provision of automatic indicators, warnings and fail-safe methods;

- .3 improved coverage and availability of consistent quality Electronic Navigational Charts (ENCs);
- .4 introduction of standardized equipment with an S-Mode* option but without restricting the ability of manufacturers to innovate;
- .5 enhanced navigation system resilience, leading to improved reliability and integrity; and
- .6 better integration of ship and shore-based systems; leading to better utilization of all human resources;
- .2 better protection of the environment both by:
 - .1 improving navigation safety as above, thereby reducing the risk of collisions and groundings and the associated spillages and pollution;
 - .2 reducing emissions by using optimum routes and speeds; and
 - .3 enhancement of ability and capacity in responding and handling of emergencies such as oil spills;
- .3 augmented security by enabling silent operation mode for shore-based stakeholders for domain surveillance and monitoring;
- .4 higher efficiency and reduced costs enabled by:
 - .1 global standardization and type approval of equipment augmented by a “fast track” change management process (in relation to technical standards for equipment);
 - .2 automated and standardized reporting procedures, leading to reduced administrative overheads;
 - .3 improved bridge efficiency allowing watchkeepers to maximize time to keeping a proper lookout and embrace existing good practice, e.g., using more than one method to ascertain the ship’s position; and
 - .4 integration of systems that are already in place, precipitating the efficient and coherent use of new equipment that meets all user requirements;
- .5 improved human resource management by enhancing the experience and status of the bridge team.

* S-Mode is the proposed functionality for shipborne navigation displays using a standard, default presentation, menu system and interface.

7 BASIC REQUIREMENTS FOR THE IMPLEMENTATION AND OPERATION OF E-NAVIGATION

7.1 To attain these benefits, a number of basic requirements should be fulfilled as enablers to the implementation and operation of e-navigation. In particular:

- .1 implementation of e-navigation should be based on user needs not technology-driven and over-reliance should not be placed on technology to avoid, for example:
 - .1 system failures causing delays because the ship is now deemed unseaworthy;
 - .2 loss of basic good seamanship by crews;
 - .3 inappropriate substitution of the human element by technology; and
 - .4 degradation of bridge resource management and best practices by the crew;
- .2 operating procedures should be put in place and kept under review, most notably in relation to the human/machine interface, the training and development of mariners and the roles, responsibilities and accountabilities of ship- and shore-based users;
- .3 the mariner should continue to play the core role in decision making even as the supporting role of the shore-based users increases;
- .4 human factors and ergonomics should be core to the system design to ensure optimum integration including the Human Machine Interface (HMI), presentation and scope of information avoiding overload, assurance of integrity and adequate training;
- .5 adequate resources should be made available and assured both for e-navigation itself and the necessary enablers such as training and radio-spectrum;
- .6 implementation should be measured and not over-hasty; and
- .7 costs should not be excessive.

8 POTENTIAL USERS OF E-NAVIGATION AND THEIR HIGH-LEVEL NEEDS

8.1 A significant number of potential ship and shore-based users of e-navigation have been identified and are summarized at annex 2.

8.2 A methodology was used to capture evolving user needs. It was based on the elements contained within the accepted definition of e-navigation and applied templates to define specific user needs based on the harmonized collection, integration, exchange, presentation, analysis and human element aspects for all users. Following extensive feedback from Member States, other maritime organizations, and interested parties, an analysis was conducted resulting in the

identification of high-level generic user needs for both ship and shore users. Thus the needs of a typical SOLAS ship and a generic shore authority have been used as the basis for the identification of the high-level user needs reproduced below. A more detailed user needs may have to be identified as a part of the implementation plan.

.1 Common maritime information/data structure

Mariners require information pertaining to the planning and execution of voyages, the assessment of navigation risk and compliance with regulation. This information should be accessible from a single integrated system. Shore users require information pertaining to their maritime domain, including static and dynamic information on vessels and their voyages. This information should be provided in an internationally agreed common data structure. Such a data structure is essential for the sharing of information amongst shore authorities on a regional and international basis.

.2 Automated and standardized reporting functions

E-navigation should provide automated and standardized reporting functions for optimal communication of ship and voyage information. This includes safety-related information that is transmitted ashore, sent from shore to shipborne users and information pertaining to security and environmental protection to be communicated amongst all users. Reporting requirements should be automated or pre-prepared to the extent possible both in terms of content and communications technology. Information exchange should be harmonized and simplified to reduce reporting requirements. It is recognized that security, legal and commercial issues will have to be considered in addressing communications needs.

.3 Effective and robust communications

A clear need was expressed for there to be an effective and robust means of communications for ship and shore users. Shore-based users require an effective means of communicating with vessels to facilitate safety, security and environmental protection and to provide operational information. To be effective, communication with and between vessels should make best use of audio/visual aids and standard phrases to minimize linguistic challenges and distractions to operators.

.4 Human centred presentation needs

Navigation displays should be designed to clearly indicate risk and to optimize support for decision making. There is a need for an integrated “alert management system” as contained in the revised recommendation on performance standards for Integrated Navigation Systems (INS) (resolution MSC.252(83)). Consideration should be given to the use of decision support systems that offer suggested responses to certain alerts, and the integration of navigation alerts on board ships within a whole ship alert management system. Users require uniform and consistent presentations and operation functionality to enhance the effectiveness of internationally standardized training, certification and familiarization. The concept of S-Mode has been widely supported as an application on board ship

during the work of the Correspondence Group. Shore users require displays that are fully flexible supporting both a Common Operating Picture (COP) and a User Defined Operating Picture (UDOP) with layered and/or tabulated displays. All displays should be designed to limit the possibility of confusion and misinterpretation when sharing safety-related information. E-navigation systems should be designed to engage and motivate the user while managing workload.

.5 Human machine interface

As electronic systems take on a greater role, facilities need to be developed for the capture and presentation of information from visual observations, as well as user knowledge and experience. The presentation of information for all users should be designed to reduce “single person errors” and enhance team operations. There is a clear need for the application of ergonomic principles both in the physical layout of equipment and in the use of light, colours, symbology and language.

.6 Data and system integrity

E-navigation systems should be resilient and take into account issues of data validity, plausibility and integrity for the systems to be robust, reliable and dependable. Requirements for redundancy, particularly in relation to position fixing systems, should be considered.

.7 Analysis

E-navigation systems should support good decision making, improve performance and prevent single person error. To do so, shipboard systems should include analysis functions that support the user in complying with regulations, voyage planning, risk assessment, and avoiding collisions and groundings including the calculation of Under Keel Clearance (UKC) and air draughts. Shore-based systems should support environmental impact analysis, forward planning of vessel movements, hazard/risk assessment, reporting indicators and incident prevention. Consideration should also be given to the use of analysis for incident response and recovery, risk assessment and response planning, environment protection measures, incident detection and prevention, risk mitigation, preparedness, resource (e.g., asset) management and communication.

.8 Implementation issues

Best practices, training and familiarization relating to aspects of e-navigation for all users should be effective and established in advance of technical implementation. The use of simulation to establish training needs and assess its effectiveness is endorsed. E-navigation should as far as practical be compatible forwards and backwards and support integration with equipment and systems made mandatory under international and national carriage requirements and performance standards. The highest level of interoperability between e-navigation and external systems should be sought where practicable.

9 KEY STRATEGY ELEMENTS AND IMPLEMENTATION

KEY STRATEGY ELEMENTS

9.1 The key strategy elements for e-navigation based on user needs include: Architecture, Human Element, Convention and Standards, Position Fixing, Communication Technology and Information Systems, ENCs, Equipment and Standardization and Scalability are detailed below.

.1 Architecture

The overall conceptual, functional and technical architecture will need to be developed and maintained, particularly in terms of process description, data structures, information systems, communications technology and regulations.

.2 Human element

Training, competency, language skills, workload and motivation are identified as essential. Alert management, information overload and ergonomics are prominent concerns. These aspects of e-navigation will have to be taken into account in accordance with IMO's human element work.

.3 Conventions and standards

The provision and development of e-navigation should consider relevant international conventions, regulations and guidelines, national legislation and standards. The development and implementation of e-navigation should build upon the work of IMO*.

.4 Position fixing

Position fixing systems will need to be provided that meet user needs in terms of accuracy, integrity, reliability and system redundancy in accordance with the level of risk and volume of traffic.

.5 Communications technology and information systems

Communications technology and information systems will have to be identified to meet user needs. This work may involve the enhancement of existing systems or the development of new systems. Any impacts affecting existing systems will need to be identified and addressed, based on technical standards and protocols for data structure, technology, and bandwidth and frequency allocations.

.6 ENCs

At NAV 53 IHO reported, "There would be adequate coverage of consistent ENCs by the time any further mandatory carriage requirements were likely to be adopted by IMO". The Sub-Committee was also of the opinion that the availability of ENCs

* Includes but not limited to the requirements prescribed in SOLAS, MARPOL and STCW Conventions.

worldwide was most important and requested IHO and Member Governments to continue their efforts in increasing the coverage. E-navigation will likely benefit from increased functionality of the future IHO S-100 standard.

.7 Equipment standardization

This part of the work will follow the development of performance standards and will involve users and manufacturers.

.8 Scalability

IMO Member States have a responsibility for the safety of all classes of vessels. This may include the scalability of e-navigation for all potential users. Extension of the concept to non-SOLAS vessels should be seen as an important task, to be addressed, in the first instance through consultation on user requirements.

IMPLEMENTATION

Clear ownership and control

9.2 The governance of the e-navigation concept should reside in a single institution that has the technical, operational and legal competences needed to define and enforce the overarching framework with implementation, operation and enforcement taking place at the appropriate level – global, regional, national or local – within that framework. This approach does not mean that the governing organization has to carry out all tasks in-house – it can delegate as appropriate to competent bodies. Being responsible for establishing mandatory standards for enhancing the safety of life at sea, maritime security and protection of the marine environment as well as having a global remit, IMO is the only organization that is capable of meeting the overall governance requirement. Responsibilities that come with the ownership and control of the concept are specified in annex 1.

Implementation of the e-navigation strategy

9.3 The implementation plan will need to identify responsibilities and appropriate methods of delivery. Implementation of the strategy will also need to take into account promotion of the e-navigation concept to key stakeholder and user groups.

9.4 In order to capture evolving user needs, it is important that the implementation strategy elements remain under review. A structured approach will be required to capture evolving user needs, making use of the existing agreed methodology, to incorporate any ensuing changes into the strategy and implementation plan.

Strategy implementation plan

9.5 A strategy implementation plan should include priorities for deliverables, resource management and a schedule for implementation and the continual assessment of user needs. The identification of commonalities across users making best use of existing capabilities and systems should be considered. In the future, the deployment of new technologies should be based on a systematic assessment of how the technology can best meet defined and evolving user needs within the open structured e-navigation concept. Similarly, proposed changes to tasks and

process, such as those resulting from the analysis of maritime accidents, should also incorporate the assessment of user needs. Co-operation with relevant maritime projects should be maintained throughout the implementation process in order to benefit from synergies.

Potential components of an e-navigation implementation process

9.6 Implementation of e-navigation should be a phased iterative process of continuous development including, but not necessarily limited to, the steps shown in the following figure:

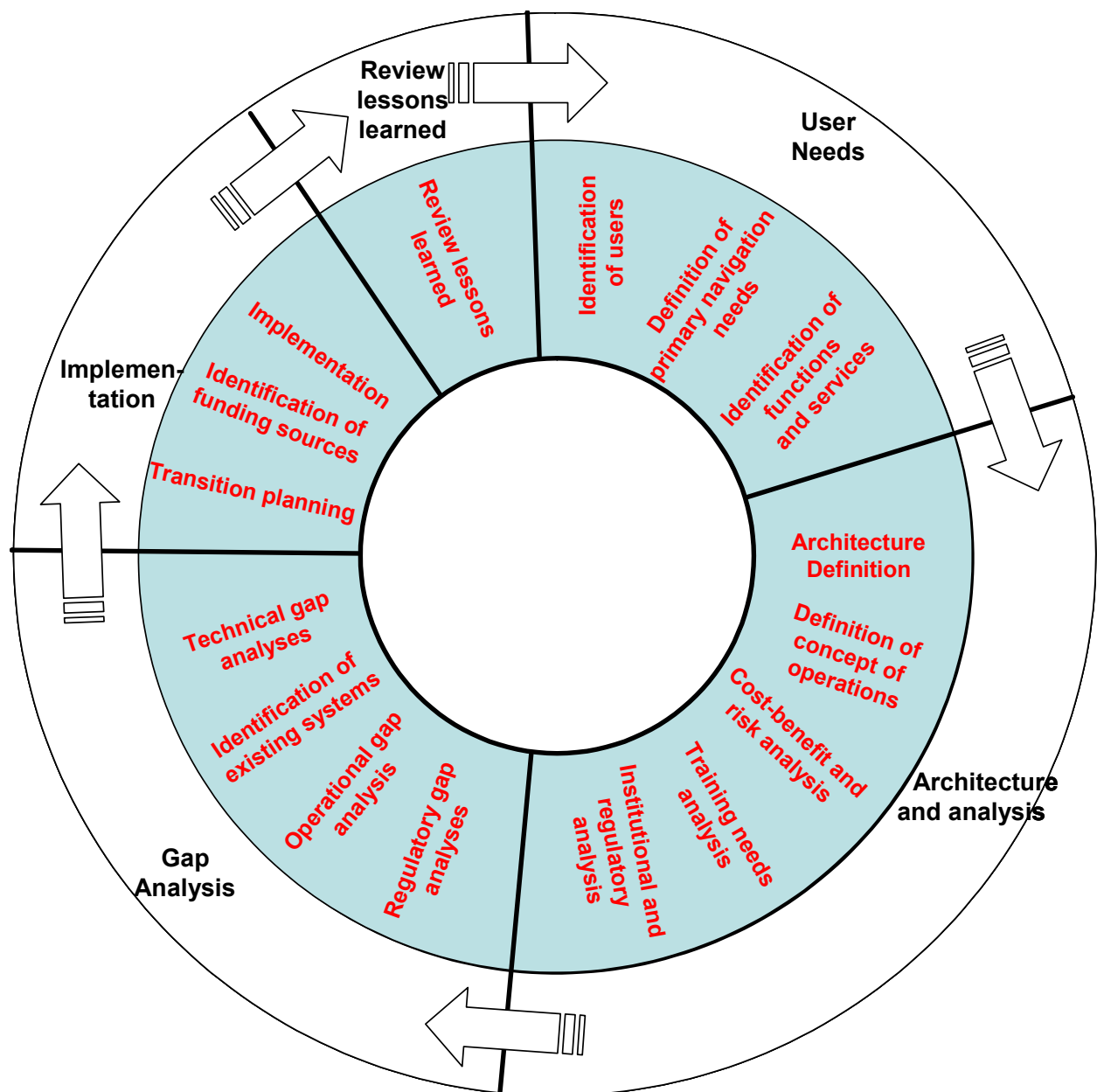

9.7 The potential components of an e-navigation implementation plan are given below:

.1 User needs

The first step in the plan is that of identification of users and their requirements. The next step should be the identification of the groups of functions or services needed to meet these primary navigational needs, based on a structured, systematic and traceable methodology that relates the functions to tangible operational benefits;

.2 Architecture and analysis

.1 *Definition*

Definition of the integrated e-navigation system architecture and concept of operations should be based on consolidation of the user needs across the entire range of users, taking account all possible economies of scale. The architecture should include hardware, data, information, communications and software needed to meet the user needs;

.2 *Cost-benefit and risk analysis*

Cost-benefit and risk analysis should be an integral part of the programme. It should be used to inform strategic decisions, but also to support decision-making on where and when certain functions need to be enabled;

.3 *Training needs analysis*

Training needs analysis should be performed based on the system architecture and operational concept resulting in a training specification; and

.4 *Institutional and regulatory requirements analysis*

Institutional and regulatory requirements analysis should be undertaken, based on the system architecture and operational concepts;

.3 Gap analysis

The gap analysis should focus on the following elements:

- .1 regulatory gap analyses particularly identifying gaps in the present frameworks that need to be filled, e.g., in the provision of services in international waters. Based on this analysis, any institutional reform that is needed should be proposed for implementation;
- .2 operational gap analysis to define a reduced concept of operations that could be used based on the integration of existing technology and systems;

- .3 identification and description of existing systems that could be integrated into the e-navigation concept* covering functionality, reliability, operational management responsibilities, regulatory status as to specification/standardization, fitment and use, generational status and integration with e-navigation system requirements; and
- .4 technical gap analyses, comparing the capabilities and properties of existing systems with the architectural requirements to identify any technology or system development that might be needed, based solely on the user needs. This should result in a programme of development work that needs to be done to provide technology solutions to user requirements in their entirety.

Implementation of e-navigation

9.8 The implementation plan should identify responsibilities to the appropriate parties – IMO, other international organizations, States, users and industry – as well as timelines for implementation actions and reviews. A stable and realistic implementation plan will create forward enthusiasm and momentum for e-navigation across the maritime sector.

9.9 Implementation plan for e-navigation should comprise a number of component activities as described below:

- .1 transition planning, taking into account the phasing needed to deliver early benefits and to make the optimum use of existing systems and services in the short term. The implementation plan should be phased such that the first phase can be achieved by fully integrating and standardizing existing technology and systems (the reduced architecture identified during the gap analysis) and using a reduced concept of operations. Subsequent phases should develop and implement any new technology that is required to deliver the preferred architecture and implement the overall concept of operations;
- .2 identification of potential sources of funding for development and implementation, particularly for developing regions and countries and taking actions to secure that funding; and
- .3 implementation itself, in phases, perhaps based on a voluntary equipage of (integrated) existing systems to begin with, but with mandatory equipage and use of a full e-navigation solution in the longer term.

Review of lessons learnt

9.10 The final phase of the iterative implementation programme should be to review, lessons learned and re-plan the subsequent phases of the plan. It is important to understand that e-navigation is not a static concept, and that development of logical implementation phases will be ongoing as user requirements evolve and also as technology develops enabling more efficient and effective systems. However, it is critical that this development takes place around a stable set of core systems and functions configured to allow extension over time.

* See annex 1.

ANNEX 1

RESPONSIBILITIES FOR OWNERSHIP AND CONTROL OF THE E-NAVIGATION CONCEPT BY IMO

The responsibilities that come with IMO ownership and control of the concept include:

- .1 development and maintenance of the vision;
- .2 definition of the services including their scope in terms of users and geography, and the concept of operations;
- .3 identification of responsibilities for the design, implementation, operation and enforcement of e-navigation, acknowledging the rights, obligations and limitations of flag States, coastal States, port States and the various authorities within those States;
- .4 defining the transition to e-navigation in a phased approach, enabling the realization of early benefits and the re-use of existing and emerging equipment, systems and services;
- .5 taking the lead in setting the performance standards appropriate for e-navigation covering all the dimensions of the system: shipborne, ashore and communications. These standards should be based on user needs and should encourage technology neutrality and interoperability of system components;
- .6 ensuring that the concept accommodates and builds on existing maritime systems and funding programmes;
- .7 facilitating access to funding from international agencies, such as the World Bank, the regional Development Banks as well as international development funding;
- .8 assessing and defining the training requirements associated with e-navigation and assisting the relevant bodies in developing and delivering the necessary training programmes;
- .9 monitor the implementation of the concept to ensure that contracting States are fulfilling their obligations and ensuring that e-navigation users within their jurisdiction are also complying with requirements; and
- .10 leading and coordinating the external communications effort necessary to support the case for e-navigation.

ANNEX 2

POTENTIAL E-NAVIGATION USERS

The tables below provide examples of e-navigation users classified into:

shipborne users, and

shore-based users.

Shipborne users
Generic SOLAS ships
Commercial tourism craft
High-speed craft
Mobile VTS assets
Pilot vessels
Coastguard vessels
SAR vessels
Law enforcement vessels (police, customs, border control, immigration, fisheries inspection)
Nautical assistance vessels (tugs, salvage vessels, tenders, fire fighting, etc.)
Counter pollution vessels
Military vessels
Fishing vessels
Leisure craft
Ferries
Dredgers
AtoN service vessels
Ice patrol/breakers
Offshore energy vessels (rigs, supply vessels, lay barges, survey vessels, construction vessels, cable layers, guard ships, production storage vessels)
Hydrographic survey vessels
Oceanographic research vessels

Shore-based users
Ship owners and operators, safety managers
VTM organizations
VTS centres
Pilot organizations
Coastguard organizations
Law enforcement organizations
National administrations
Coastal administrations
Port authorities
Security organizations
Port State control authorities
Incident managers
Counter pollution organizations
Military organizations
Fairway maintenance organizations
AtoN organizations
Meteorological organizations
Hydrographic Offices/Agencies
Ship owners and operators, logistics managers
News organizations
Coastal management authorities
Marine accident investigators
Health and safety organizations
Insurance and financial organizations
National, regional and local governments and administration
Port authorities (strategic)
Ministries
Marine environment managers
Fisheries management
Tourism agencies (logistics)
Energy providers
Ocean research institutes
Training organizations
Equipment and system manufacturers and maintainers

ANNEX 21

FRAMEWORK FOR THE IMPLEMENTATION PROCESS FOR THE E-NAVIGATION STRATEGY

Introduction

1 In order to implement e-navigation several steps are required. This would include a number of elements such as developing an architecture, gap analysis, cost benefit analysis and the creation of a detailed implementation plan.

2 In order to capture evolving user needs, it is important that the implementation strategy elements remain constantly under review. A structured and a phased approach would be required to capture evolving user needs, making use of the existing agreed methodology, to incorporate any ensuing changes into the strategy and implementation plan.

Strategy implementation plan

3 A strategy implementation plan for e-navigation should include priorities for deliverables and a schedule for implementation and the continual assessment of user needs. The deployment of new technologies should be based on a systematic assessment of how the technology can best meet defined and evolving user needs within the e-navigation concept.

User needs

4 The first step in the implementation process, i.e. identifying the initial user needs^{*}, has been completed and includes the groups of functions/services needed to meet primary navigational needs based on a structured, systematic and traceable methodology that leads to tangible operational benefits. More detailed user needs, in particular scaled solutions, may need to be developed as a part of the overall implementation plan. The initial user needs should be further reviewed and prioritized by 2009.

Architecture

5 The architecture should include the hardware, data, information, communications technology and software needed to meet the user needs. The system architecture should be based on a modular and scalable concept. The system hardware and software should be based on open architectures to allow scalability of functions according to the needs of different users and to cater to continued development and enhancement. This initial architecture should be ready for a coordinated review by 2009 and should be completed by 2010.

Gap analysis

6 Preliminary gap analysis has already been started by the Sub-Committee. Taking into account the human element throughout the process, further gap analyses should focus on technical, regulatory, operational and training aspects. It is recognized that these aspects are inter-related and need to be considered in a coordinated manner. The initial gap analyses needs to be completed by 2010.

* See document NAV 54/13, annex 5.

Cost-benefit and risk analyses

7 Cost-benefit and risk analyses should be an integral part of the plan. They should be used to support strategic decisions as and when certain functions need to be enabled. The analyses should address financial and economic aspects as well as assess the impact on safety, security and the environment. This should be completed by 2011.

Implementation plan

8 On completion of the aforementioned steps, implementation of the e-navigation plan could begin in 2012 and should include:

- .1 identification of responsibilities to the appropriate organizations/parties;
- .2 transition planning; and
- .3 a phased implementation schedule along with possible roadmaps* to clarify common understanding necessary for the implementation.

* The example provided by Japan in document NAV 54/13/4 could be used as a template.

ANNEX 22

**RESOLUTION MSC.281(85)
(adopted on 4 December 2008)**

**EXPLANATORY NOTES TO THE SOLAS CHAPTER II-1 SUBDIVISION AND
DAMAGE STABILITY REGULATIONS**

THE MARITIME SAFETY COMMITTEE,

RECALLING Article 28(b) of the Convention on the International Maritime Organization concerning the function of the Committee,

RECALLING ALSO that, by resolution MSC.216(82), it adopted the regulations on subdivision and damage stability as contained in SOLAS chapter II-1 which are based on the probabilistic concept, using the probability of survival after collision as a measure of ships' safety in a damaged condition,

NOTING that, at the eighty-second session, it approved Interim Explanatory Notes to the SOLAS chapter II-1 subdivision and damage stability regulations (MSC.1/Circ.1226), to assist Administrations in the uniform interpretation and application of the aforementioned subdivision and damage stability regulations,

BEING DESIROUS that definitive Explanatory Notes should be adopted when more experience in the application of the the aforementioned subdivision and damage stability regulations and the Interim Explanatory Notes had been gained,

RECOGNIZING that the appropriate application of the Explanatory Notes is essential for ensuring the uniform application of the SOLAS chapter II-1 subdivision and damage stability regulations,

HAVING CONSIDERED, at its eighty-fifth session, the recommendations made by the Sub-Committee on Stability and Load Lines and on Fishing Vessels Safety at its fifty-first session,

1. ADOPTS the Explanatory Notes to the SOLAS chapter II-1 subdivision and damage stability regulations set out in the Annex to the present resolution;
2. URGES Governments and all parties concerned to utilize the Explanatory Notes when applying the SOLAS chapter II-1 subdivision and damage stability regulations adopted by resolution MSC.216(82).

**EXPLANATORY NOTES TO THE SOLAS CHAPTER II-1
SUBDIVISION AND DAMAGE STABILITY REGULATIONS**

Contents

Part A – INTRODUCTION

**Part B – GUIDANCE ON INDIVIDUAL SOLAS CHAPTER II-1 SUBDIVISION AND
DAMAGE STABILITY REGULATIONS**

Regulation 1	Application
Regulation 2	Definitions
Regulation 4	General
Regulation 5	Intact stability information
Regulation 5-1	Stability information to be supplied to the master
Regulation 6	Required subdivision index R
Regulation 7	Attained subdivision index A
Regulation 7-1	Calculation of the factor p_i
Regulation 7-2	Calculation of the factor s_i
Regulation 7-3	Permeability
Regulation 8	Special requirements concerning passenger ship stability
Regulation 8-1	System capabilities after a flooding casualty on passenger ships
Regulation 9	Double bottoms in passenger ships and cargo ships other than tankers
Regulation 10	Construction of watertight bulkheads
Regulation 12	Peak and machinery space bulkheads, shaft tunnels, etc.
Regulation 13	Openings in watertight bulkheads below the bulkhead deck in passenger ships
Regulation 13-1	Openings in watertight bulkheads and internal decks in cargo ships
Regulation 15	Openings in the shell plating below the bulkhead deck of passenger ships and the freeboard deck of cargo ships
Regulation 15-1	External openings in cargo ships
Regulation 16	Construction and initial tests of watertight doors, sidescuttles, etc.
Regulation 17	Internal watertight integrity of passenger ships above the bulkhead deck
Appendix	Guidelines for the preparation of subdivision and damage stability calculations

PART A

INTRODUCTION

1 The harmonized SOLAS regulations on subdivision and damage stability, as contained in SOLAS chapter II-1, are based on a probabilistic concept which uses the probability of survival after collision as a measure of ships' safety in a damaged condition. This probability is referred to as the "attained subdivision index A " in the regulations. It can be considered an objective measure of ships' safety and, ideally, there would be no need to supplement this index by any deterministic requirements.

2 The philosophy behind the probabilistic concept is that two different ships with the same attained index are of equal safety and, therefore, there is no need for special treatment of specific parts of the ship, even if they are able to survive different damages. The only areas which are given special attention in the regulations are the forward and bottom regions, which are dealt with by special subdivision rules provided for cases of ramming and grounding.

3 Only a few deterministic elements, which were necessary to make the concept practicable, have been included. It was also necessary to include a deterministic "minor damage" on top of the probabilistic regulations for passenger ships to avoid ships being designed with what might be perceived as unacceptably vulnerable spots in some part of their length.

4 It is easily recognized that there are many factors that will affect the final consequences of hull damage to a ship. These factors are random and their influence is different for ships with different characteristics. For example, it would seem obvious that in ships of similar size carrying different amounts of cargo, damages of similar extents may lead to different results because of differences in the range of permeability and draught during service. The mass and velocity of the ramming ship is obviously another random variable.

5 Due to this, the effect of a three-dimensional damage to a ship with given watertight subdivision depends on the following circumstances:

- .1 which particular space or group of adjacent spaces is flooded;
- .2 the draught, trim and intact metacentric height at the time of damage;
- .3 the permeability of affected spaces at the time of damage;
- .4 the sea state at the time of damage; and
- .5 other factors such as possible heeling moments due to unsymmetrical weights.

6 Some of these circumstances are interdependent and the relationship between them and their effects may vary in different cases. Additionally, the effect of hull strength on penetration will obviously have some effect on the results for a given ship. Since the location and size of the damage is random, it is not possible to state which part of the ship becomes flooded. However, the probability of flooding a given space can be determined if the probability of occurrence of certain damages is known from experience, that is, damage statistics. The probability of flooding a space is then equal to the probability of occurrence of all such damages which just open the considered space to the sea.

7 For these reasons and because of mathematical complexity as well as insufficient data, it would not be practicable to make an exact or direct assessment of their effect on the probability that a particular ship will survive a random damage if it occurs. However, accepting some approximations or qualitative judgments, a logical treatment may be achieved by using the probability approach as the basis for a comparative method for the assessment and regulation of ship safety.

8 It may be demonstrated by means of probability theory that the probability of ship survival should be calculated as the sum of probabilities of its survival after flooding each single compartment, each group of two, three, etc., adjacent compartments multiplied, respectively, by the probabilities of occurrence of such damages leading to the flooding of the corresponding compartment or group of compartments.

9 If the probability of occurrence for each of the damage scenarios the ship could be subjected to is calculated and then combined with the probability of surviving each of these damages with the ship loaded in the most probable loading conditions, we can determine the attained index A as a measure for the ship's ability to sustain a collision damage.

10 It follows that the probability that a ship will remain afloat without sinking or capsizing as a result of an arbitrary collision in a given longitudinal position can be broken down to:

- .1 the probability that the longitudinal centre of damage occurs in just the region of the ship under consideration;
- .2 the probability that this damage has a longitudinal extent that only includes spaces between the transverse watertight bulkheads found in this region;
- .3 the probability that the damage has a vertical extent that will flood only the spaces below a given horizontal boundary, such as a watertight deck;
- .4 the probability that the damage has a transverse penetration not greater than the distance to a given longitudinal boundary; and
- .5 the probability that the watertight integrity and the stability throughout the flooding sequence is sufficient to avoid capsizing or sinking.

11 The first three of these factors are solely dependent on the watertight arrangement of the ship, while the last two depend on the ship's shape. The last factor also depends on the actual loading condition. By grouping these probabilities, calculations of the probability of survival, or attained index A , have been formulated to include the following probabilities:

- .1 the probability of flooding each single compartment and each possible group of two or more adjacent compartments; and
- .2 the probability that the stability after flooding a compartment or a group of two or more adjacent compartments will be sufficient to prevent capsizing or dangerous heeling due to loss of stability or to heeling moments in intermediate or final stages of flooding.

12 This concept allows a rule requirement to be applied by requiring a minimum value of A for a particular ship. This minimum value is referred to as the “required subdivision index R ” in the present regulations and can be made dependent on ship size, number of passengers or other factors legislators might consider important.

13 Evidence of compliance with the rules then simply becomes:

$$A \geq R$$

13.1 As explained above, the attained subdivision index A is determined by a formula for the entire probability as the sum of the products for each compartment or group of compartments of the probability that a space is flooded, multiplied by the probability that the ship will not capsize or sink due to flooding of the considered space. In other words, the general formula for the attained index can be given in the form:

$$A = \sum p_i s_i$$

13.2 Subscript “ i ” represents the damage zone (group of compartments) under consideration within the watertight subdivision of the ship. The subdivision is viewed in the longitudinal direction, starting with the aftmost zone/compartment.

13.3 The value of “ p_i ” represents the probability that only the zone “ i ” under consideration will be flooded, disregarding any horizontal subdivision, but taking transverse subdivision into account. Longitudinal subdivision within the zone will result in additional flooding scenarios, each with its own probability of occurrence.

13.4 The value of “ s_i ” represents the probability of survival after flooding the zone “ i ” under consideration.

14 Although the ideas outlined above are very simple, their practical application in an exact manner would give rise to several difficulties if a mathematically perfect method was to be developed. As pointed out above, an extensive but still incomplete description of the damage will include its longitudinal and vertical location as well as its longitudinal, vertical and transverse extent. Apart from the difficulties in handling such a five-dimensional random variable, it is impossible to determine its probability distribution very accurately with the presently available damage statistics. Similar limitations are true for the variables and physical relationships involved in the calculation of the probability that a ship will not capsize or sink during intermediate stages or in the final stage of flooding.

15 A close approximation of the available statistics would result in extremely numerous and complicated computations. In order to make the concept practicable, extensive simplifications are necessary. Although it is not possible to calculate the exact probability of survival on such a simplified basis, it has still been possible to develop a useful comparative measure of the merits of the longitudinal, transverse and horizontal subdivision of a ship.

PART B

GUIDANCE ON INDIVIDUAL SOLAS CHAPTER II-1 SUBDIVISION AND DAMAGE STABILITY REGULATIONS

REGULATION 1 – APPLICATION

Regulation 1.3

If a passenger ship built before 1 January 2009 undergoes alterations or modifications of major character, it may still remain under the damage stability regulations applicable to ships built before 1 January 2009, except in the case of a cargo ship being converted to a passenger ship.

REGULATION 2 – DEFINITIONS

Regulation 2.1

Subdivision length (L_s) – Different examples of L_s showing the buoyant hull and the reserve buoyancy are provided in the figures below. The limiting deck for the reserve buoyancy may be partially watertight.

The maximum possible vertical extent of damage above the baseline is $d_s + 12.5$ metres.

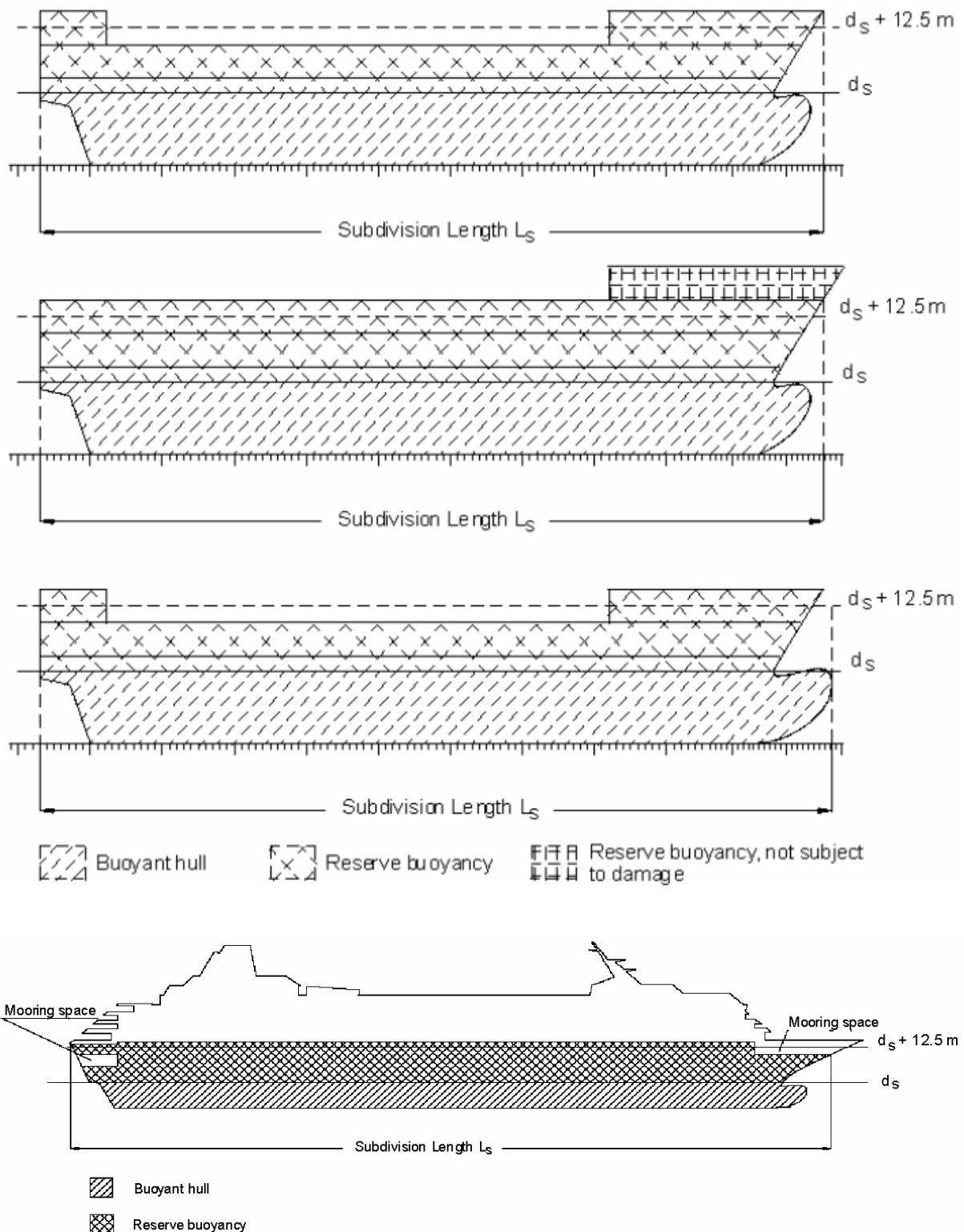

Regulation 2.6

Freeboard deck – See Explanatory Notes for regulation 13-1* for the treatment of a stepped freeboard deck with regard to watertightness and construction requirements.

* References to regulations in these Guidelines are to regulations of SOLAS chapter II-1, unless expressly provided otherwise.

Regulation 2.11

Light service draught (d_l) – The light service draught (d_l) represents the lower draught limit of the minimum required *GM* (or maximum allowable *KG*) curve. It corresponds, in general, to the ballast arrival condition with 10% consumables for cargo ships. For passenger ships, it corresponds, in general, to the arrival condition with 10% consumables, a full complement of passengers and crew and their effects, and ballast as necessary for stability and trim. The 10% arrival condition is not necessarily the specific condition that should be used for all ships, but represents, in general, a suitable lower limit for all loading conditions. This is understood to not include docking conditions or other non-voyage conditions.

Regulation 2.19

Bulkhead deck – See Explanatory Notes for regulation 13 for the treatment of a stepped bulkhead deck with regard to watertightness and construction requirements.

REGULATION 4 – GENERAL

Regulation 4.1

Cargo ships complying with the subdivision and damage stability regulations of other IMO instruments listed in the footnote are not required to comply with part B-1, regulations 6, 7, 7-1, 7-2 and 7-3, but should comply with the regulations indicated in the table below.

Regulation	Applies
Part B-1	
5	X
5-1	X
Part B-2	
9	X ⁽¹⁾
10	X
11	X
12	X
13-1	X
15	X
15-1	X
16	X
16-1	X
Part B-4	
19	X
22	X
24	X
25	X ⁽²⁾

(1) Only applies to cargo ships other than tankers.

(2) Only applies to single hold cargo ships other than bulk carriers.

Regulation 4.1, footnote .1

“OBO ships” means *combination carriers* as defined in SOLAS regulation II-2/3.14.

Regulation 4.4

See Explanatory Notes for regulation 7-2.2, for information and guidance related to these provisions.

REGULATION 5 – INTACT STABILITY INFORMATION

Reference is made to MSC/Circ.1158 (Unified interpretation of SOLAS chapter II-1) regarding lightweight check.

REGULATION 5-1 – STABILITY INFORMATION TO BE SUPPLIED TO THE MASTER

Regulation 5-1.2

Any limiting *GM* (or *KG*) requirements arising from provisions in regulation 6.1 (regarding partial attained subdivision indices), regulation 8 or regulation 9, which are in addition to those described in regulation 5-1.4, should also be taken into account when developing this information.

Regulations 5-1.3 and 5-1.4 (see also regulation 7.2)

1 Linear interpolation of the limiting values between the draughts d_s , d_p and d_l is only applicable to minimum *GM* values. If it is intended to develop curves of maximum permissible *KG*, a sufficient number of KM_T values for intermediate draughts should be calculated to ensure that the resulting maximum *KG* curves correspond with a linear variation of *GM*. When light service draught is not with the same trim as other draughts, KM_T for draughts between partial and light service draught should be calculated for trims interpolated between trim at partial draught and trim at light service draught.

2 In cases where the operational trim range is intended to exceed $\pm 0.5\%$ of L_s , the original *GM* limit line should be designed in the usual manner with the deepest subdivision draught and partial subdivision draught calculated at level trim and actual service trim used for the light service draught. Then additional sets of *GM* limit lines should be constructed on the basis of the operational range of trims which is covered by loading conditions of partial subdivision draught and deepest subdivision draught ensuring that intervals of $1\% L_s$ are not exceeded. For the light service draught d_l only one trim should be considered. The sets of *GM* limit lines are combined to give one envelope limiting *GM* curve. The effective trim range of the curve should be clearly stated.

REGULATION 6 – REQUIRED SUBDIVISION INDEX R

Regulation 6.1

To demonstrate compliance with these provisions, see the Guidelines for the preparation of subdivision and damage stability calculations, set out in the appendix, regarding the presentation of damage stability calculation results.

Regulation 6.2.4

Regarding the term “reduced degree of hazard”, the following interpretation should be applied: A lesser value of N , but in no case less than $N = N_1 + N_2$, may be allowed at the discretion of the Administration for passenger ships, which, in the course of their voyages, do not proceed more than 20 miles from the nearest land.

REGULATION 7 – ATTAINED SUBDIVISION INDEX A

Regulation 7.1

1 The probability of surviving after collision damage to the ship’s hull is expressed by the index A . Producing an index A requires calculation of various damage scenarios defined by the extent of damage and the initial loading conditions of the ship before damage. Three loading conditions should be considered and the result weighted as follows:

$$A = 0.4A_s + 0.4A_p + 0.2A_l$$

where the indices s , p and l represent the three loading conditions and the factor to be multiplied to the index indicates how the index A from each loading condition is weighted.

2 The method of calculating A for a loading condition is expressed by the formula:

$$A_c = \sum_{i=1}^{i=t} p_i [v_i s_i]$$

2.1 The index c represents one of the three loading conditions, the index i represents each investigated damage or group of damages and t is the number of damages to be investigated to calculate A_c for the particular loading condition.

2.2 To obtain a maximum index A for a given subdivision, t has to be equal to T , the total number of damages.

3 In practice, the damage combinations to be considered are limited either by significantly reduced contributions to A (i.e. flooding of substantially larger volumes) or by exceeding the maximum possible damage length.

4 The index A is divided into partial factors as follows:

- | | |
|-------|---|
| p_i | The p factor is solely dependent on the geometry of the watertight arrangement of the ship. |
| v_i | The v factor is dependent on the geometry of the watertight arrangement (decks) of the ship and the draught of the initial loading condition. It represents the probability that the spaces above the horizontal subdivision will not be flooded. |
| s_i | The s factor is dependent on the calculated survivability of the ship after the considered damage for a specific initial condition. |

5 Three initial loading conditions should be used for calculating the index A . The loading conditions are defined by their mean draught d , trim and GM (or KG). The mean draught and trim are illustrated in the figure below.

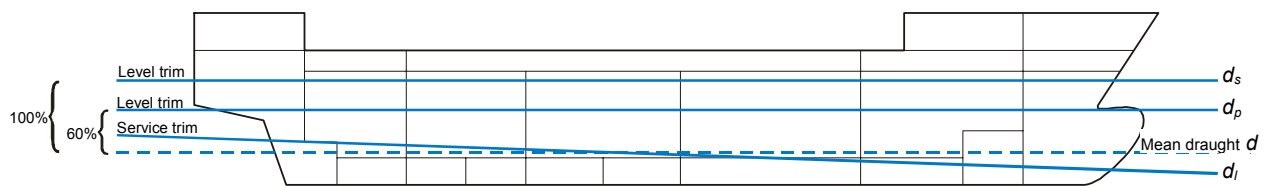

6 The GM (or KG) values for the three loading conditions could, as a first attempt, be taken from the intact stability GM (or KG) limit curve. If the required index R is not obtained, the GM (or KG) values may be increased (or reduced), implying that the intact loading conditions from the intact stability book must now meet the GM (or KG) limit curve from the damage stability calculations derived by linear interpolation between the three GM s.

Regulation 7.2

1 The calculations for differing trim should be carried out with the same initial trim for the partial and deepest subdivision draughts. For the light service draught, the actual service trim should be used (refer to the Explanatory Notes for regulation 2.11).

2 Each combination of the index within the formula given in regulation 7.1 should not be less than the requirement given in regulation 6.2. Each partial index A should comply with the requirements of regulation 6.1.

3 Example:

Based on the GM limiting curves obtained from damage stability calculations of each trim, an envelope curve covering all calculated trim values should be developed.

Calculations covering different trim values should be carried out in steps not exceeding 1% of L_s . The whole range including intermediate trims should be covered by the damage stability calculations. Refer to the example showing an envelope curve obtained from calculations of 0 trim and 1% of L_s .

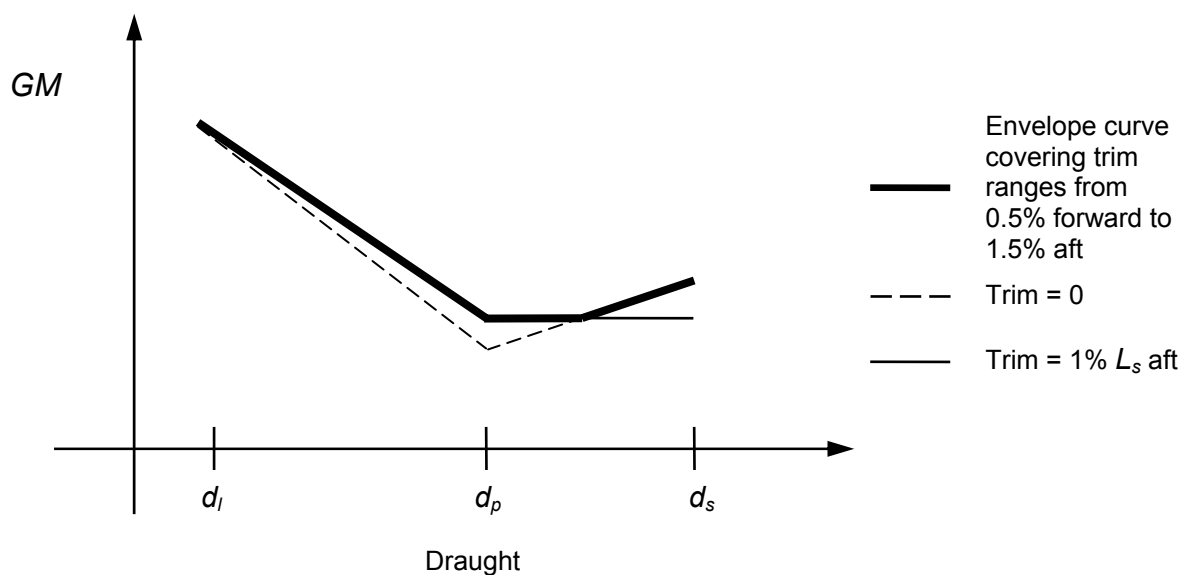

Regulation 7.5

1 With the same intent as wing tanks, the summation of the attained index A should reflect effects caused by all watertight bulkheads and flooding boundaries within the damaged zone. It is not correct to assume damage only to the centreline and ignore changes in subdivision that would reflect lesser contributions.

2 In the forward and aft ends of the ship where the sectional breadth is less than the ship's breadth B , transverse damage penetration can extend beyond the centreline bulkhead. This application of the transverse extent of damage is consistent with the methodology to account for the localized statistics which are normalized on the greatest moulded breadth B rather than the local breadth.

3 Where longitudinal corrugated bulkheads are fitted in wing compartments or on the centreline, they may be treated as equivalent plane bulkheads provided the corrugation depth is of the same order as the stiffening structure. The same principle may also be applied to transverse corrugated bulkheads.

Regulation 7.7

1 Pipes and valves directly adjacent to a bulkhead or to a deck can be considered to be part of the bulkhead or deck, provided the separation distance is of the same order as the bulkhead or deck stiffening structure. The same applies for small recesses, drain wells, etc.

2 The provision for allowing "minor progressive flooding" should be limited to pipes penetrating a watertight subdivision with a total cross-sectional area of not more than 710 mm^2 between any two watertight compartments.

REGULATION 7-1 – CALCULATION OF THE FACTOR p_i

General

- 1 The definitions below are intended to be used for the application of part B-1 only.
- 2 In regulation 7-1, the words “compartment” and “group of compartments” should be understood to mean “zone” and “adjacent zones”.
- 3 Zone – a longitudinal interval of the ship within the subdivision length.
- 4 Room – a part of the ship, limited by bulkheads and decks, having a specific permeability.
- 5 Space – a combination of rooms.
- 6 Compartment – an onboard space within watertight boundaries.
- 7 Damage – the three dimensional extent of the breach in the ship.
- 8 For the calculation of p , v , r and b only the damage should be considered, for the calculation of the s -value the flooded space should be considered. The figures below illustrate the difference.

Damage shown as the bold square:

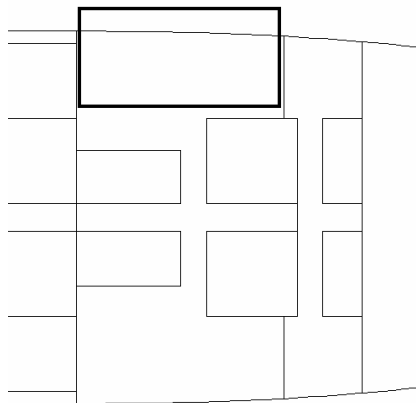

Flooded space shown below:

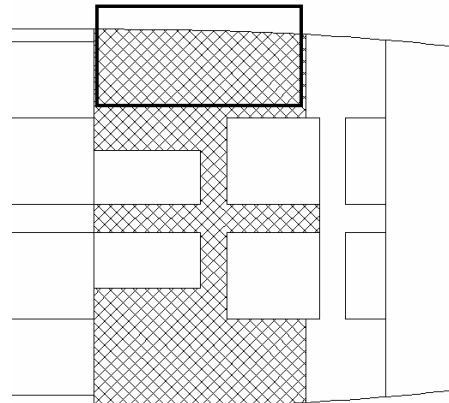

Regulation 7-1.1.1

- 1 The coefficients b_{11} , b_{12} , b_{21} and b_{22} are coefficients in the bi-linear probability density function on normalized damage length (J). The coefficient b_{12} is dependent on whether L_s is greater or less than L^* (i.e. 260 m); the other coefficients are valid irrespective of L_s .

Longitudinal subdivision

- 2 In order to prepare for the calculation of index A , the ship's subdivision length L_s is divided into a fixed discrete number of damage zones. These damage zones will determine the damage stability investigation in the way of specific damages to be calculated.

3 There are no rules for the subdividing, except that the length L_s defines the extremes for the actual hull. Zone boundaries need not coincide with physical watertight boundaries. However, it is important to consider a strategy carefully to obtain a good result (that is a large attained index A). All zones and combination of adjacent zones may contribute to the index A . In general it is expected that the more zone boundaries the ship is divided into the higher will be the attained index, but this benefit should be balanced against extra computing time. The figure below shows different longitudinal zone divisions of the length L_s .

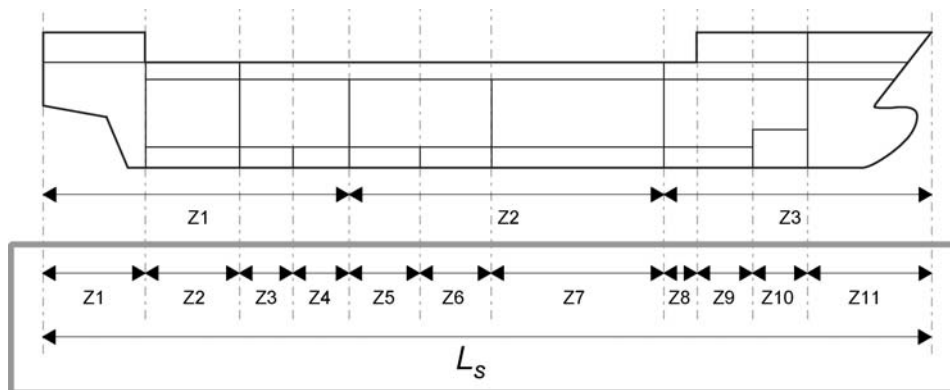

4 The first example is a very rough division into three zones of approximately the same size with limits where longitudinal subdivision is established. The probability that the ship will survive a damage in one of the three zones is expected to be low (i.e. the s -factor is low or zero) and, therefore, the total attained index A will be correspondingly low.

5 In the second example the zones have been placed in accordance with the watertight arrangement, including minor subdivision (as in double bottom, etc.). In this case there is a much better chance of obtaining higher s -factors.

6 Where transverse corrugated bulkheads are fitted, they may be treated as equivalent plane bulkheads, provided the corrugation depth is of the same order as the stiffening structure.

7 Pipes and valves directly adjacent to a transverse bulkhead can be considered to be part of the bulkhead, provided the separation distance is of the same order as the bulkhead stiffening structure. The same applies for small recesses, drain wells, etc.

8 For cases where the pipes and valves are outside the transverse bulkhead stiffening structure, when they present a risk of progressive flooding to other watertight compartments that will have influence on the overall attained index A , they should be handled either by introducing a new damage zone and accounting for the progressive flooding to associated compartments or by introducing a gap.

9 The triangle in the figure below illustrates the possible single and multiple zone damages in a ship with a watertight arrangement suitable for a seven-zone division. The triangles at the bottom line indicate single zone damages and the parallelograms indicate adjacent zones damages.

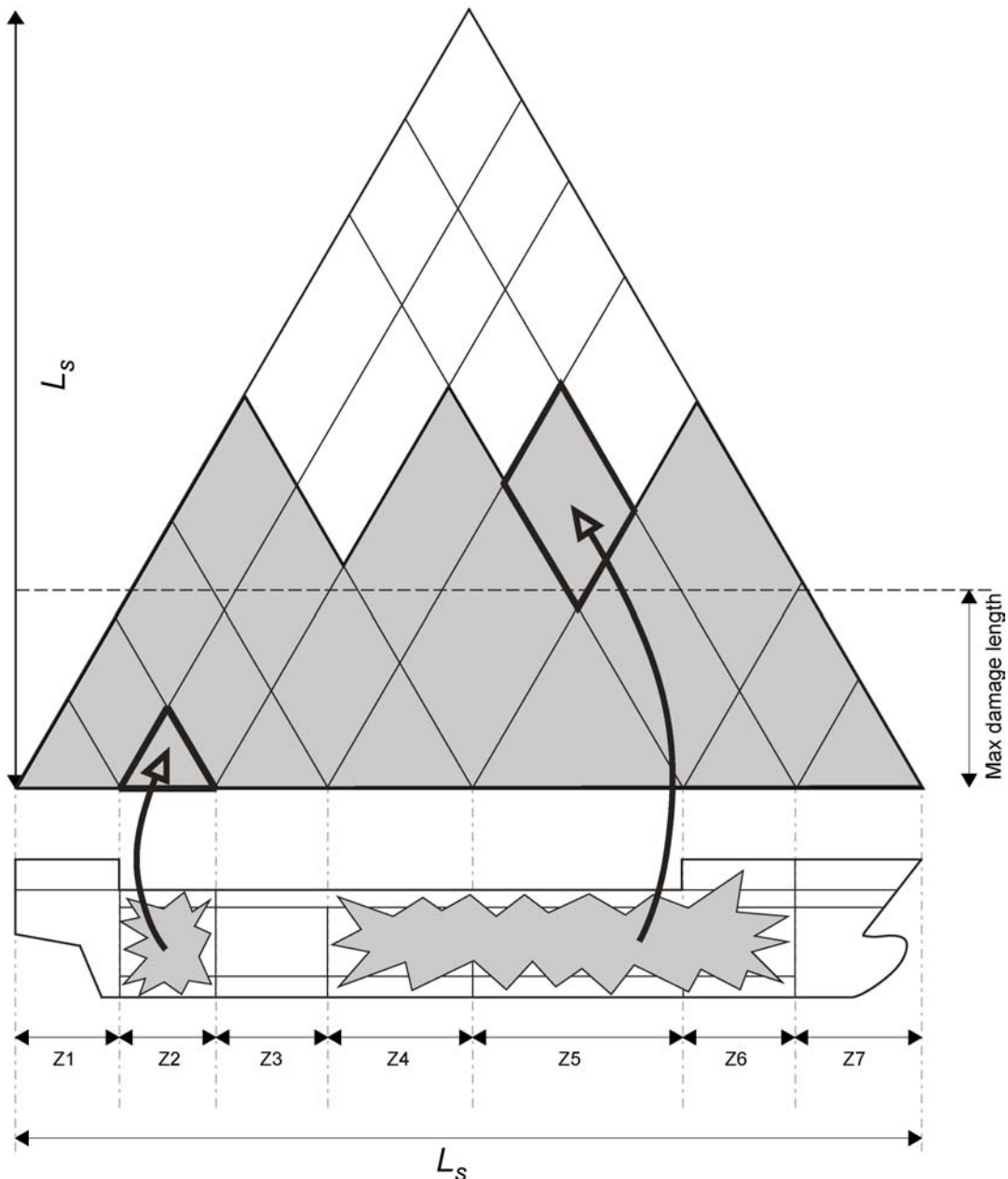

10 As an example, the triangle illustrates a damage opening the rooms in zone 2 to the sea and the parallelogram illustrates a damage where rooms in the zones 4, 5 and 6 are flooded simultaneously.

11 The shaded area illustrates the effect of the maximum absolute damage length. The p -factor for a combination of three or more adjacent zones equals zero if the length of the combined adjacent damage zones minus the length of the foremost and the aft most damage zones in the combined damage zone is greater than the maximum damage length. Having this in mind when subdividing L_s could limit the number of zones defined to maximize the attained index A .

12 As the p -factor is related to the watertight arrangement by the longitudinal limits of damage zones and the transverse distance from the ship side to any longitudinal barrier in the zone, the following indices are introduced:

- j : the damage zone number starting with No.1 at the stern;
- n : the number of adjacent damage zones in question where j is the aft zone;
- k : the number of a particular longitudinal bulkhead as a barrier for transverse penetration in a damage zone counted from shell towards the centreline. The shell has No.0;
- K : total number of transverse penetration boundaries;
- $p_{j,n,k}$: the p -factor for a damage in zone j and next $(n-1)$ zones forward of j damaged to the longitudinal bulkhead k .

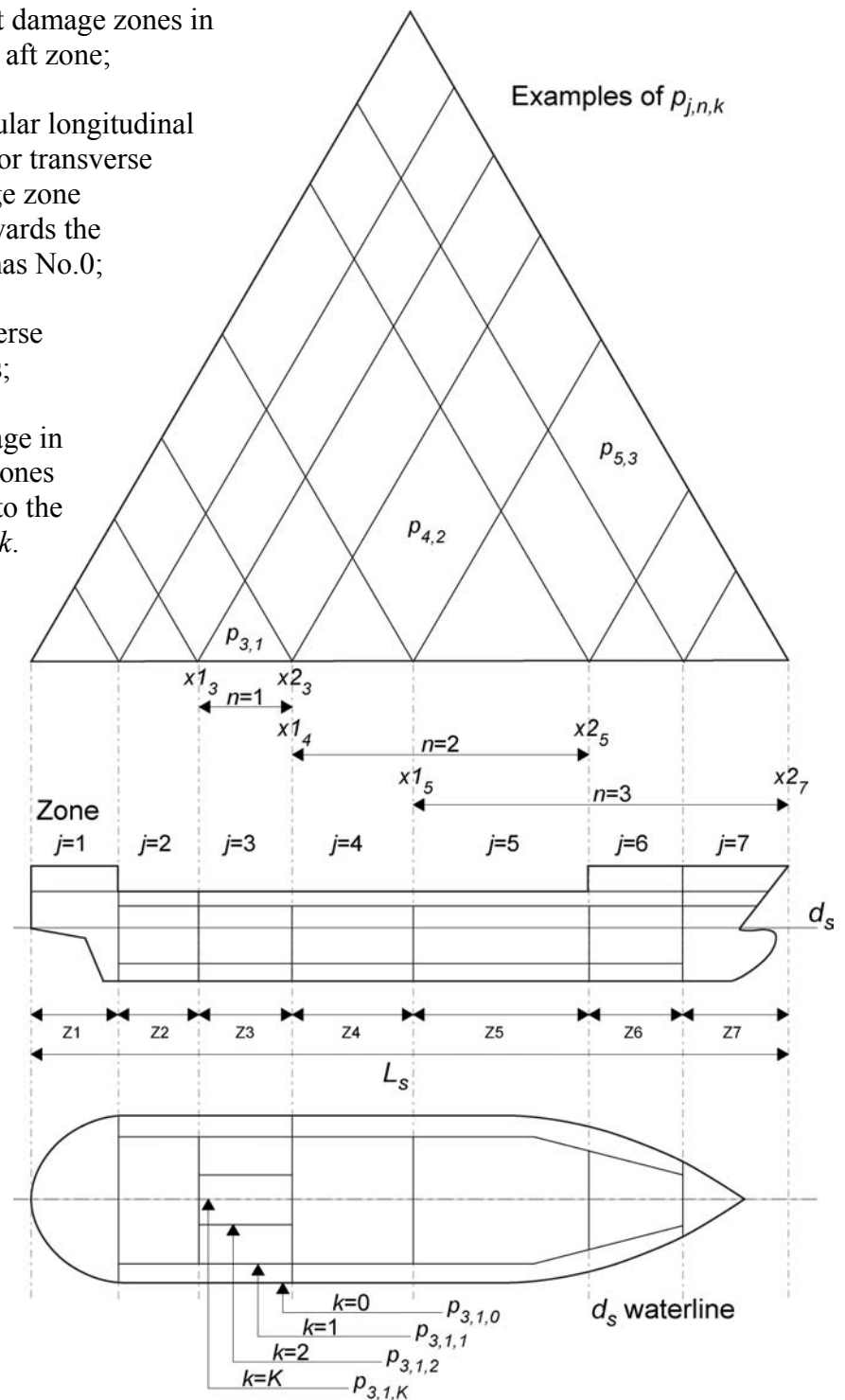

Pure longitudinal subdivision

Single damage zone, pure longitudinal subdivision:

$$p_{j,1} = p(x1_j, x2_j)$$

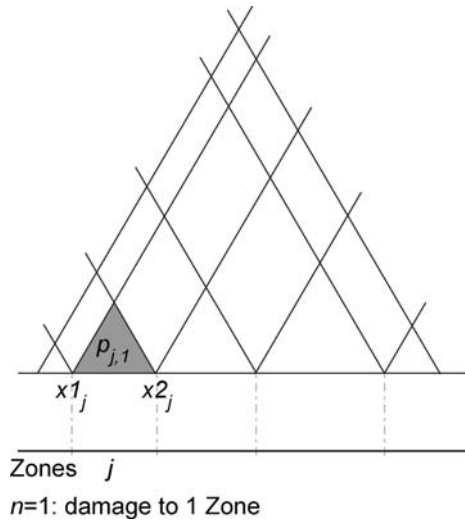

Two adjacent zones, pure longitudinal subdivision:

$$p_{j,2} = p(x1_j, x2_{j+1}) - p(x1_j, x2_j) - p(x1_{j+1}, x2_{j+1})$$

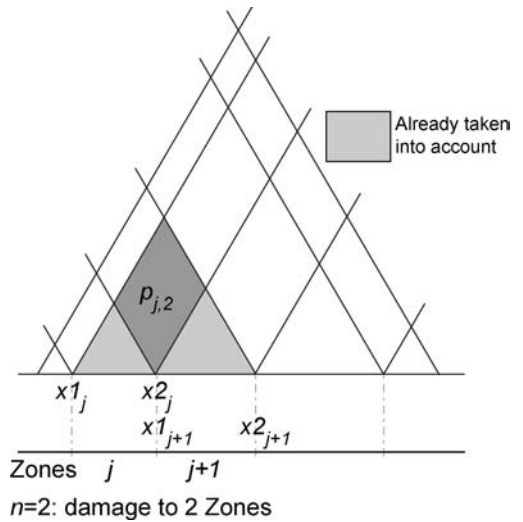

Three or more adjacent zones, pure longitudinal subdivision:

$$p_{j,n} = p(x1_j, x2_{j+n-1}) - p(x1_j, x2_{j+n-2}) - p(x1_{j+1}, x2_{j+n-1}) + p(x1_{j+1}, x2_{j+n-2})$$

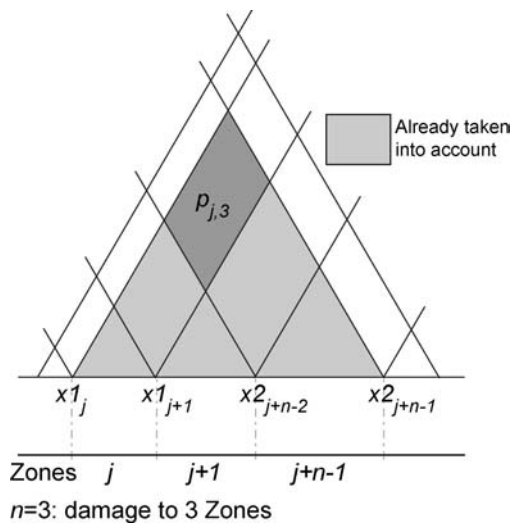

Regulation 7-1.1.2

Transverse subdivision in a damage zone

1 Damage to the hull in a specific damage zone may just penetrate the ship's watertight hull or penetrate further towards the centreline. To describe the probability of penetrating only a wing compartment, a probability factor r is used, based mainly on the penetration depth b . The value of r is equal to 1, if the penetration depth is $B/2$ where B is the maximum breadth of the ship at the deepest subdivision draught d_s , and $r = 0$ if $b = 0$.

2 The penetration depth b is measured at level deepest subdivision draught d_s as a transverse distance from the ship side right-angled to the centreline to a longitudinal barrier.

3 Where the actual watertight bulkhead is not a plane parallel to the shell, b should be determined by means of an assumed line, dividing the zone to the shell in a relationship b_1/b_2 with $1/2 \leq b_1/b_2 \leq 2$.

4 Examples of such assumed division lines are illustrated in the figure below. Each sketch represents a single damage zone at a water line plane level d_s and the longitudinal bulkhead represents the outermost bulkhead position below $d_s + 12.5$ m.

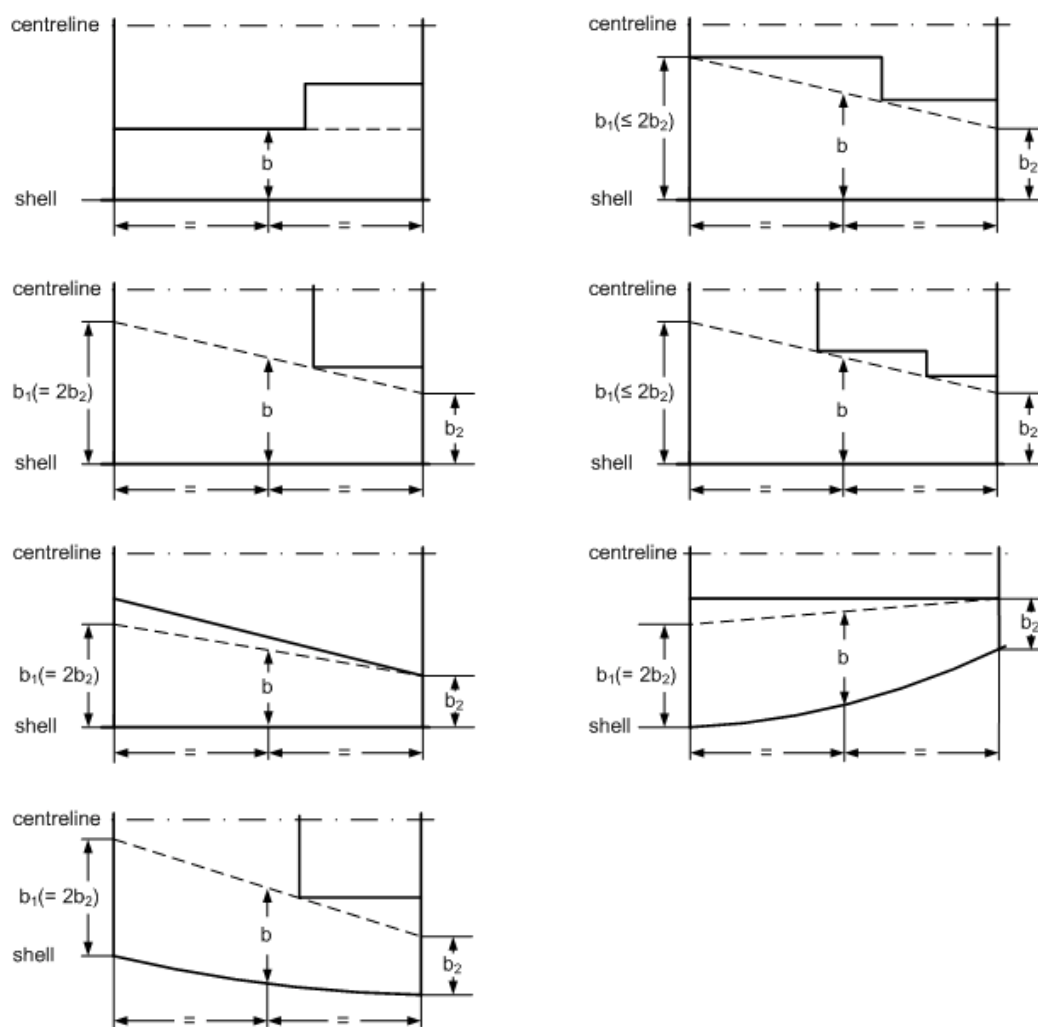

5 In calculating r -values for a group of two or more adjacent compartments, the b -value is common for all compartments in that group, and equal to the smallest b -value in that group:

$$b = \min\{b_1, b_2, \dots, b_n\}$$

where: $n =$ number of wing compartments in that group;
 $b_1, b_2, \dots, b_n =$ mean values of b for individual wing compartments contained in the group.

Accumulating p

6 The accumulated value of p for one zone or a group of adjacent zones is determined by:

$$p_{j,n} = \sum_{k=1}^{k=K_{j,n}} p_{j,n,k}$$

where $K_{j,n} = \sum_j^{j+n-1} K_j$ the total number of b_k 's for the adjacent zones in question.

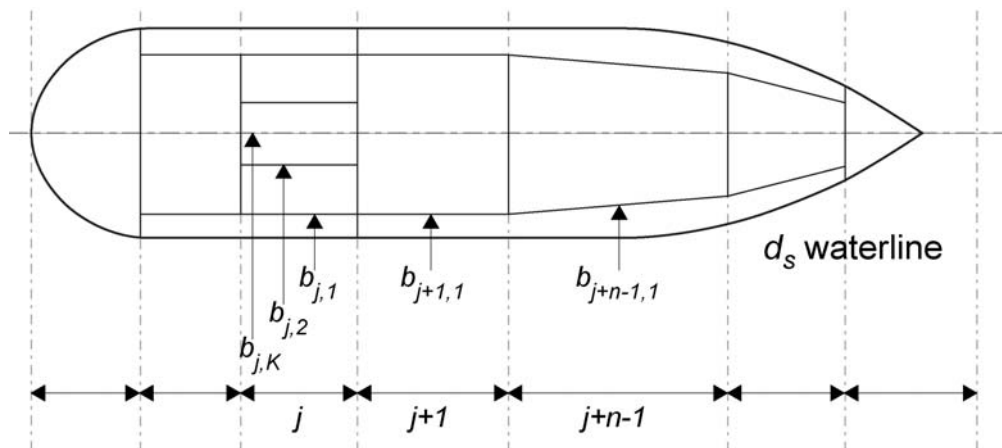

7 The figure above illustrates b 's for adjacent zones. The zone j has two penetration limits and one to the centre, the zone $j+1$ has one b and the zone $j+n-1$ has one value for b . The multiple zones will have $(2+1+1)$ four values of b , and sorted in increasing order they are:

$$(b_{j,1}; b_{j+1,1}; b_{j+n-1,1}; b_{j,2}; b_K)$$

8 Because of the expression for $r(x1, x2, b)$ only one b_K should be considered. To minimize the number of calculations, b 's of the same value may be deleted.

As $b_{j,1} = b_{j+1,1}$ the final b 's will be $(b_{j,1}; b_{j+n-1,1}; b_{j,2}; b_K)$

Examples of multiple zones having a different b

9 Examples of combined damage zones and damage definitions are given in the figures below. Compartments are identified by R10, R12, etc.

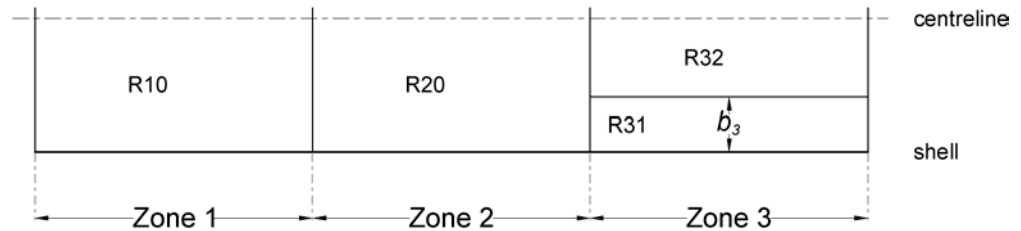

Figure: Combined damage of zones 1 + 2 + 3 includes a limited penetration to b_3 , taken into account generating two damages:

- 1) to b_3 with R10, R20 and R31 damaged;
- 2) to $B/2$ with R10, R20, R31 and R32 damaged.

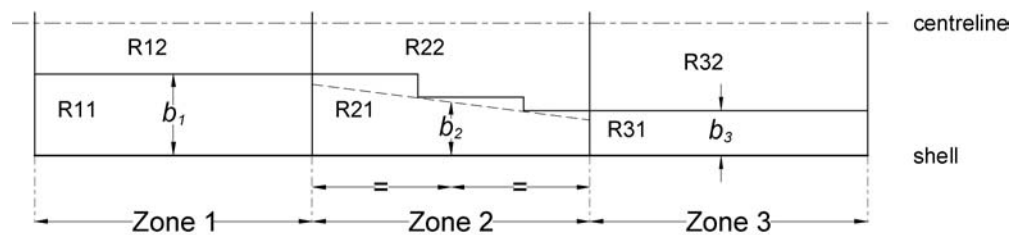

Figure: Combined damage of zones 1 + 2 + 3 includes 3 different limited damage penetrations generating four damages:

- 1) to b_3 with R11, R21 and R31 damaged;
- 2) to b_2 with R11, R21, R31 and R32 damaged;
- 3) to b_1 with R11, R21, R31, R32, and R22 damaged;
- 4) to $B/2$ with R11, R21, R31, R32, R22 and R12 damaged.

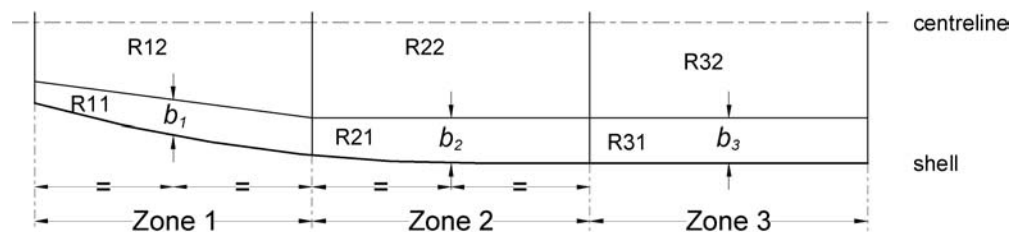
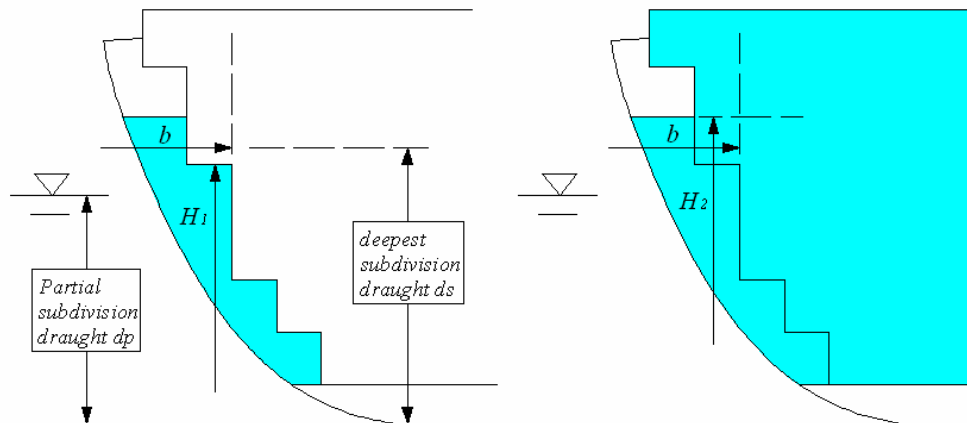

Figure: Combined damage of zone 1 + 2 + 3 including 2 different limited damage penetrations ($b_1 < b_2 = b_3$) generating three damages:

- 1) to b_1 with R11, R21 and R31 damaged;
- 2) to b_2 with R11, R21, R31 and R12, damaged;
- 3) to $B/2$ with R11, R21, R31, R12, R22 and R32 damaged.

10 A damage having a transverse extent b and a vertical extent H_2 leads to the flooding of both wing compartment and hold; for b and H_1 only the wing compartment is flooded. The figure below illustrates a partial subdivision draught d_p damage.



11 The same is valid if b -values are calculated for arrangements with sloped walls.

12 Pipes and valves directly adjacent to a longitudinal bulkhead can be considered to be part of the bulkhead, provided the separation distance is of the same order as the bulkhead stiffening structure. The same applies for small recesses, drain wells, etc.

REGULATION 7-2 – CALCULATION OF THE FACTOR s_i

General

1 Initial condition – an intact loading condition to be considered in the damage analysis described by the mean draught, vertical centre of gravity and the trim; or alternative parameters from where the same may be determined (ex. displacement, GM and trim). There are three initial conditions corresponding to the three draughts d_s , d_p and d_l .

2 Immersion limits – immersion limits are an array of points that are not to be immersed at various stages of flooding as indicated in regulations 7-2.5.2 and 7-2.5.3.

3 Openings – all openings need to be defined: both weathertight and unprotected. Openings are the most critical factor to preventing an inaccurate index A . If the final waterline immerses the lower edge of any opening through which progressive flooding takes place, the factor “ s ” may be recalculated taking such flooding into account. However, in this case the s value should also be calculated without taking into account progressive flooding and corresponding opening. The smallest s value should be retained for the contribution to the attained index.

Regulation 7-2.1

1 In cases where the GZ curve may include more than one “range” of positive righting levers for a specific stage of flooding, only one continuous positive “range” of the GZ curve may be used within the allowable range/heel limits for calculation purposes. Different stages of flooding may not be combined in a single GZ curve.

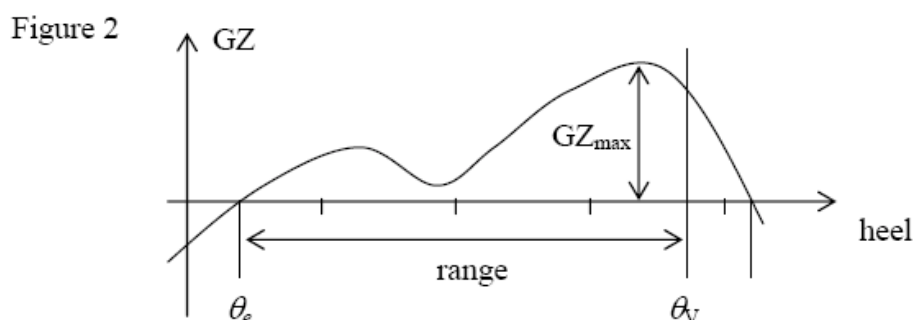
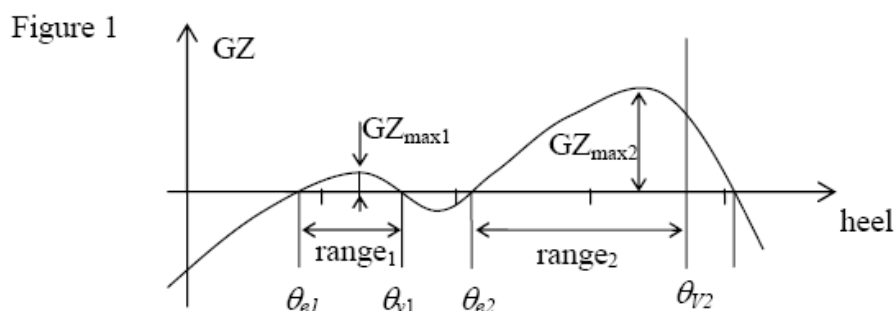

2 In figure 1, the s -factor may be calculated from the heel angle, range and corresponding GZ_{max} of the first or second “range” of positive righting levers. In figure 2, only one s -factor can be calculated.

Regulation 7-2.2

Intermediate stages of flooding

1 The case of instantaneous flooding in unrestricted spaces in way of the damage zone does not require intermediate stage flooding calculations. Where intermediate stages of flooding calculations are necessary in connection with progressive flooding, they should reflect the sequence of filling as well as filling level phases. Calculations for intermediate stages of flooding should be performed whenever equalization is not instantaneous, i.e. equalization is of a duration greater than 60 s. Such calculations consider the progress through one or more floodable (non-watertight) spaces. Bulkheads surrounding refrigerated spaces, incinerator rooms and longitudinal bulkheads fitted with non-watertight doors are typical examples of structures that may significantly slow down the equalization of main compartments.

Flooding boundaries

2 If a compartment contains decks, inner bulkheads, structural elements and doors of sufficient tightness and strength to seriously restrict the flow of water, for intermediate stage flooding calculation purposes it should be divided into corresponding non-watertight spaces. It is assumed that the non-watertight divisions considered in the calculations are limited to “A” class fire-rated bulkheads and do not apply to “B” class fire-rated bulkheads normally used in accommodation areas (e.g., cabins and corridors). This guidance also relates to regulation 4.4.

Sequential flooding computation

3 For each damage scenario, the damage extent and location determine the initial stage of flooding. Calculations should be performed in stages, each stage comprising of at least two intermediate filling phases in addition to the full phase per flooded space. Unrestricted spaces in way of damage should be considered as flooded immediately. Every subsequent stage involves all connected spaces being flooded simultaneously until an impermeable boundary or final equilibrium is reached. If due to the configuration of the subdivision in the ship it is expected that other intermediate stages of flooding are more onerous, then those should be investigated.

Cross-flooding/equalization

4 In general, cross-flooding is meant as a flooding of an undamaged space on the other side of the ship to reduce the heel in the final equilibrium condition.

5 The cross-flooding time should be calculated in accordance with the Recommendation on a standard method for evaluating cross-flooding arrangements (resolution MSC.245(83)). If complete fluid equalization occurs in 60 s or less, it should be treated as instantaneous and no further calculations need to be carried out. Additionally, in cases where $S_{final} = 1$ is achieved in 60 s or less, but equalization is not complete, instantaneous flooding may also be assumed if S_{final} will not become reduced. In any cases where complete fluid equalization exceeds 60 s, the value of $S_{intermediate}$ after 60 s is the first intermediate stage to be considered. Only passive open cross-flooding arrangements without valves should be considered effective for instantaneous flooding cases.

6 If complete fluid equalization can be finalized in 10 min or less, the assessment of survivability can be carried out for passenger ships as the smallest values of $S_{intermediate}$ or S_{final} .

7 In case the equalization time is longer than 10 min, S_{final} is calculated for the floating position achieved after 10 min of equalization. This floating position is computed by calculating the amount of flood water according to resolution MSC.245(83) using interpolation, where the equalization time is set to 10 min, i.e. the interpolation of the flood water volume is made between the case before equalization ($T = 0$) and the total calculated equalization time.

8 In any cases where complete fluid equalization exceeds 10 min, the value of S_{final} used in the formula in regulation 7-2.1.1 should be the minimum of S_{final} at 10 min or at final equalization.

Cargo ships

9 If the Administration considers that the stability in intermediate stages of flooding in a cargo ship may be insufficient, it may require further investigation thereof.

Regulation 7-2.4

The displacement is the intact displacement at the subdivision draught in question (d_s , d_p and d_i).

Regulation 7-2.4.1.1

The beam B used in this paragraph means breadth as defined in regulation 2.8.

Regulation 7-2.4.1.2

The parameter A (projected lateral area) used in this paragraph does not refer to the attained subdivision index.

Regulation 7-2.5

In cargo ships where cross-flooding devices are fitted, the safety of the ship should be maintained in all stages of flooding. The Administration may request for this to be demonstrated. Cross-flooding equipment, if installed, should have the capacity to ensure that the equalization takes place within 10 min.

Regulation 7-2.5.2.1

Unprotected openings

1 The flooding angle will be limited by immersion of such an opening. It is not necessary to define a criterion for non-immersion of unprotected openings at equilibrium, because if it is immersed, the range of positive GZ limited to flooding angle will be zero so “ s ” will be equal to zero.

2 An unprotected opening connects two rooms or one room and the outside. An unprotected opening will not be taken into account if the two connected rooms are flooded or none of these rooms are flooded. If the opening is connected to the outside, it will not be taken into account if the connected compartment is flooded. An unprotected opening does not need to be taken into account if it connects a flooded room or the outside to an undamaged room, if this room will be considered as flooded in a subsequent stage.

Openings fitted with a weathertight mean of closing (“weathertight openings”)

3 The survival “ s ” factor will be “0” if any such point is submerged at a stage which is considered as “final”. Such points may be submerged during a stage or phase which is considered as “intermediate”, or within the range beyond equilibrium.

4 If an opening fitted with a weathertight means of closure is submerged at equilibrium during a stage considered as intermediate, it should be demonstrated that this weathertight means of closure can sustain the corresponding head of water and that the leakage rate is negligible.

5 These points are also defined as connecting two rooms or one room and the outside, and the same principle as for unprotected openings is applied to take them into account or not. If several stages have to be considered as “final”, a “weathertight opening” does not need to be taken into account if it connects a flooded room or the outside to an undamaged room if this room will be considered as flooded in a successive “final” stage.

Regulation 7-2.5.2.2

1 Partial immersion of the bulkhead deck may be accepted at final equilibrium. This provision is intended to ensure that evacuation along the bulkhead deck to the vertical escapes will not be impeded by water on that deck. A “horizontal evacuation route” in the context of this regulation means a route on the bulkhead deck connecting spaces located on and under this deck with the vertical escapes from the bulkhead deck required for compliance with SOLAS chapter II-2.

2 Horizontal evacuation routes on the bulkhead deck include only escape routes (designated as category 2 stairway spaces according to SOLAS regulation II-2/9.2.2.3 or as category 4 stairway spaces according to SOLAS regulation II-2/9.2.2.4 for passenger ships carrying not more than 36 passengers) used for the evacuation of undamaged spaces. Horizontal evacuation routes do not include corridors (designated as category 3 corridor spaces according to SOLAS regulation II-2/9.2.2.3 or as category 2 corridor spaces according to SOLAS regulation II-2/9.2.2.4 for passenger ships carrying not more than 36 passengers) within the damaged space. No part of a horizontal evacuation route serving undamaged spaces should be immersed.

3 $s_i = 0$ where it is not possible to access a stair leading up to the embarkation deck from an undamaged space as a result of flooding to the “stairway” or “horizontal stairway” on the bulkhead deck.

4 Horizontal escapes situated in way of the damage extent may remain effective, therefore s_i need not be taken as zero. Contributions to the attained index A may still be gained.

Regulation 7-2.5.3.1

1 The purpose of this paragraph is to provide an incentive to ensure that evacuation through a vertical escape will not be obstructed by water from above. The paragraph is intended for smaller emergency escapes, typically hatches, where fitting of a watertight or weathertight means of closure would otherwise exclude them from being considered as flooding points.

2 Since the probabilistic regulations do not require that the watertight bulkheads be carried continuously up to the bulkhead deck, care should be taken to ensure that evacuation from intact spaces through flooded spaces below the bulkhead deck will remain possible, for instance by means of a watertight trunk.

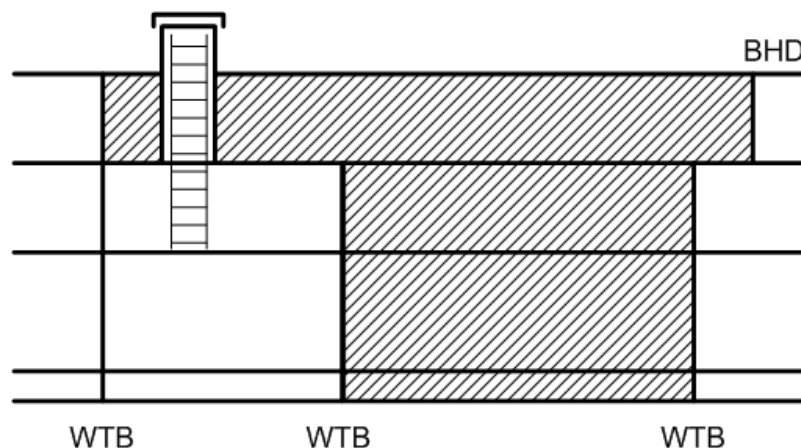

Regulation 7-2.6

The sketches in the figure illustrate the connection between position of watertight decks in the reserve buoyancy area and the use of factor ν for damages below these decks.

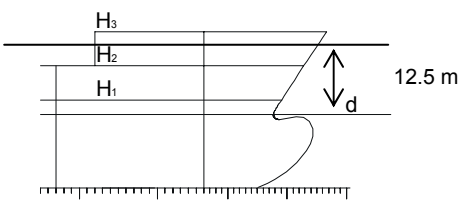
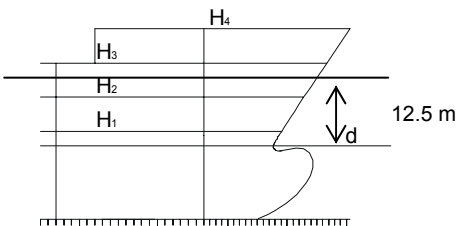
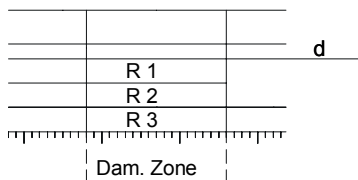
<p style="text-align: center;">Above the waterline</p>   <p style="text-align: center;">Below the waterline</p> 	<p>In this example, there are 3 horizontal subdivisions to be taken into account as the vertical extent of damage.</p> <p>The example shows the maximum possible vertical extent of damage $d + 12.5$ m is positioned between H_2 and H_3. H_1 with factor ν_1, H_2 with factor $\nu_2 > \nu_1$ but $\nu_2 < 1$ and H_3 with factor $\nu_3 = 1$.</p> <p>The factors ν_1 and ν_2 are the same as above. The reserve buoyancy above H_3 should be taken undamaged in all damage cases.</p> <p>The combination of damages into the rooms R1, R2 and R3 positioned below the initial water line should be chosen so that the damage with the lowest s-factor is taken into account. That often results in the definition of alternative damages to be calculated and compared. If the deck taken as lower limit of damage is not watertight, down flooding should be considered.</p>
--	--

Regulation 7-2.6.1

The parameters x_1 and x_2 are the same as parameters x_1 and x_2 used in regulation 7-1.

REGULATION 7-3 – PERMEABILITY

Regulation 7-3.2

1 The following additional cargo permeabilities may be used:

Spaces	Permeability at draught d_s	Permeability at draught d_p	Permeability at draught d_l
Timber cargo in holds	0.35	0.7	0.95
Wood chip cargo	0.6	0.7	0.95

2 Reference is made to MSC/Circ.998 (IACS Unified Interpretation regarding timber deck cargo in the context of damage stability requirements) regarding timber deck cargo.

Regulation 7-3.3

1 Concerning the use of other figures for permeability “if substantiated by calculations”, such permeabilities should reflect the general conditions of the ship throughout its service life rather than specific loading conditions.

2 This paragraph allows for the recalculation of permeabilities. This should only be considered in cases where it is evident that there is a major discrepancy between the values shown in the regulation and the real values. It is not designed for improving the attained value of a deficient ship of regular type by the modification of chosen spaces in the ship that are known to provide significantly onerous results. All proposals should be considered on a case-by-case basis by the Administration and should be justified with adequate calculations and arguments.

REGULATION 8 – SPECIAL REQUIREMENTS CONCERNING PASSENGER SHIP STABILITY

Regulations 8.3.2 to 8.3.5

The number of persons carried, which is specified in these paragraphs, equals the total number of persons the ship is permitted to carry (and not $N = N_1 + 2 N_2$ as defined in regulation 6).

REGULATION 8-1 – SYSTEM CAPABILITIES AFTER A FLOODING CASUALTY ON PASSENGER SHIPS

Regulation 8-1.2

1 In the context of this regulation, “compartment” has the same meaning as defined under regulation 7-1 of these Explanatory Notes (i.e. an onboard space within watertight boundaries).

2 The purpose of the paragraph is to prevent any flooding of limited extent from immobilizing the ship. This principle should be applied regardless of how the flooding might occur. Only flooding below the bulkhead deck need be considered.

REGULATION 9 – DOUBLE BOTTOMS IN PASSENGER SHIPS AND CARGO SHIPS OTHER THAN TANKERS

Regulation 9.1

1 This regulation is intended to minimize the impact of flooding from a minor grounding. Special attention should be paid to the vulnerable area at the turn of the bilge. When justifying a deviation from fitting an inner bottom an assessment of the consequences of allowing a more extensive flooding than reflected in the regulation should be provided.

2 Except as provided in regulations 9.3 and 9.4, parts of the double bottom not extended for the full width of the ship as required by regulation 9.1 should be considered an unusual arrangement for the purpose of this regulation and should be handled in accordance with regulation 9.7.

Regulation 9.2

If an inner bottom is located higher than the partial subdivision draught d_p , this should be considered an unusual arrangement and should be handled in accordance with regulation 9.7.

Regulation 9.6

1 Any part of a passenger ship or a cargo ship where a double bottom is omitted in accordance with regulation 9.1, 9.4 or 9.5 shall be capable of withstanding bottom damages, as specified in regulation 9.8. The intent of this provision is to specify the circumstances under which the Administration should require calculations, which damage extents to assume and what survival criteria to apply when double bottoms are not fitted.

2 The definition of “watertight” in regulation 2.17 implies that the strength of inner bottoms and other boundaries assumed to be watertight should be verified if they are to be considered effective in this context.

Regulation 9.7

The reference to a “plane” in regulation 9.2 does not imply that the surface of the inner bottom may not be stepped in the vertical direction. Minor steps and recesses need not be considered unusual arrangements for the purpose of this paragraph as long as no part of the inner bottom is located below the reference plane. Discontinuities in way of wing tanks are covered by regulation 9.4.

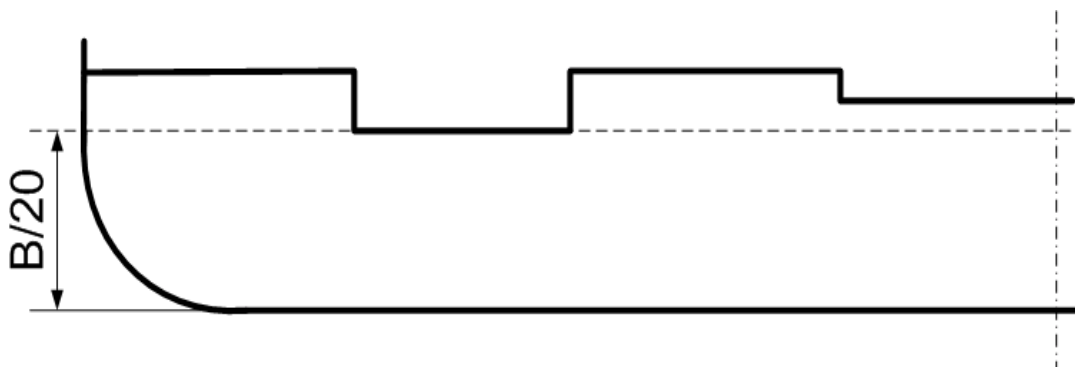

Regulation 9.8

1 The term “all service conditions” used in this paragraph means the three loading conditions used to calculate the attained subdivision index A .

2 The damage extents specified in this paragraph should be applied to all parts of the ship where no double bottom is fitted, as permitted by regulations 9.1, 9.4 or 9.5, and include any adjacent spaces located within the extent of damage. Small wells in accordance with regulation 9.3 do not need to be considered damaged even if within the extent of the damage. Possible positions of the damages are shown in an example below (parts of the ship not fitted with a double bottom are shaded; the damages to be assumed are indicated by boxes).

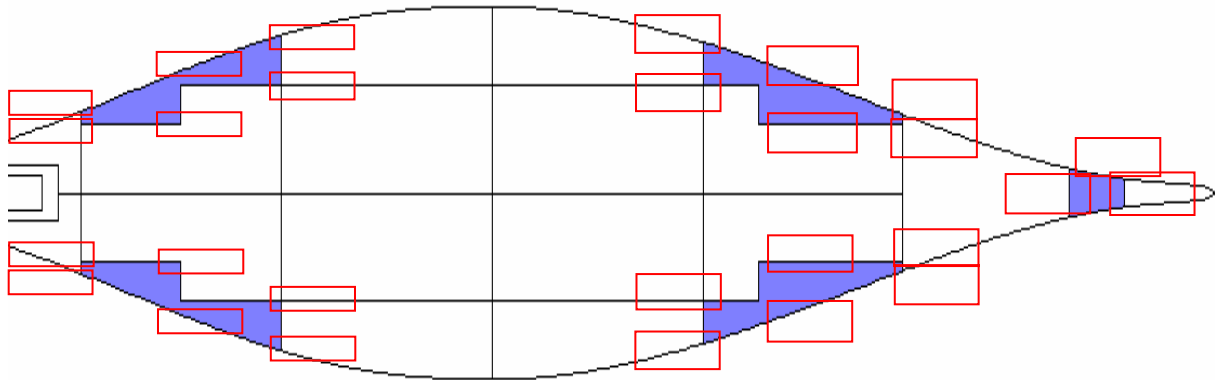

Regulation 9.9

1 For the purpose of identifying “large lower holds”, horizontal surfaces having a continuous deck area greater than approximately 30% in comparison with the waterplane area at subdivision draught should be taken to be located anywhere in the affected area of the ship. For the alternative bottom damage calculation, a vertical extent of $B/10$ or 3 m, whichever is less, should be assumed.

2 The increased minimum double bottom height of not more than $B/10$ or 3 m, whichever is less, for passenger ships with large lower holds, is applicable to holds in direct contact with the double bottom. Typical arrangements of ro-ro passenger ships may include a large lower hold with additional tanks between the double bottom and the lower hold, as shown in the figure below. In such cases, the vertical position of the double bottom required to be $B/10$ or 3 m, whichever is less, should be applied to the lower hold deck, maintaining the required double bottom height of $B/20$ or 2 m, whichever is less (but not less than 760 mm). The figure below shows a typical arrangement of a modern ro-ro passenger ferry.

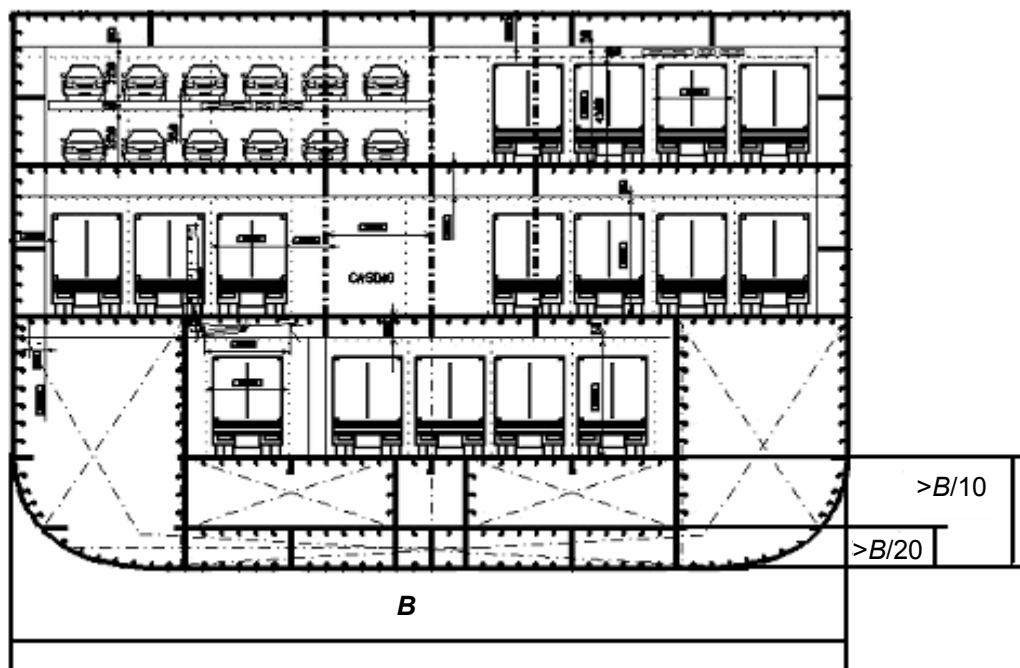

REGULATION 10 – CONSTRUCTION OF WATERTIGHT BULKHEADS

Regulation 10.1

For the treatment of steps in the bulkhead deck of passenger ships see Explanatory Notes for regulation 13. For the treatment of steps in the freeboard deck of cargo ships see Explanatory Notes for regulation 13-1.

REGULATION 12 – PEAK AND MACHINERY SPACE BULKHEADS, SHAFT TUNNELS, ETC.

Reference is made to MSC.1/Circ.1211 (Unified interpretations to SOLAS regulation II-1/10 and regulation 12 of the revised SOLAS chapter II-1 regarding bow doors and the extension of the collision bulkhead) concerning interpretations regarding bow doors and the extension of the collision bulkhead.

REGULATION 13 – OPENINGS IN WATERTIGHT BULKHEADS BELOW THE BULKHEAD DECK IN PASSENGER SHIPS

General – Steps in the bulkhead deck

1 If the transverse watertight bulkheads in a region of the ship are carried to a higher deck which forms a vertical step in the bulkhead deck, openings located in the bulkhead at the step may be considered as being located above the bulkhead deck. Such openings should then comply with regulation 17 and should be taken into account when applying regulation 7-2.

2 All openings in the shell plating below the upper deck throughout that region of the ship should be treated as being below the bulkhead deck and the provisions of regulation 15 should be applied. See figure below.

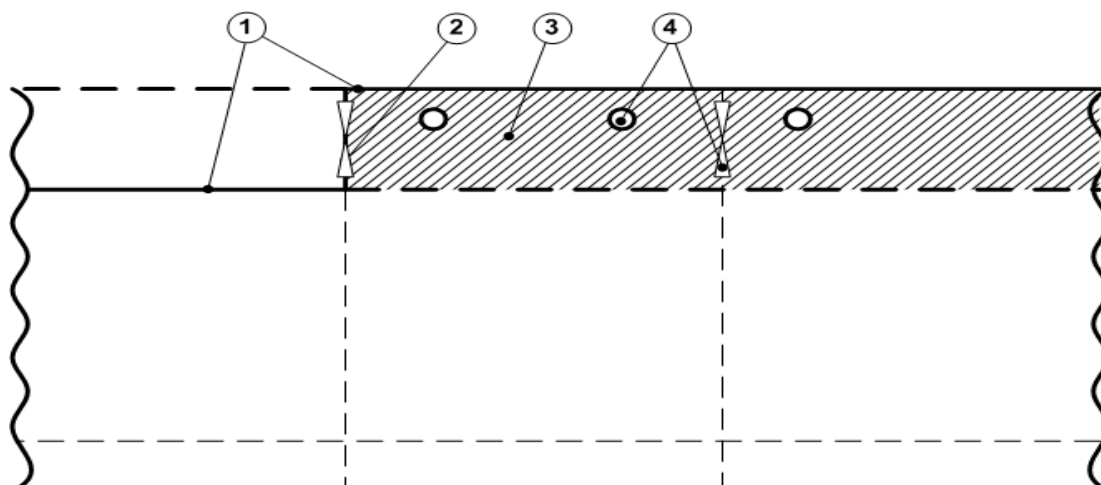

- | | |
|-----------------|---|
| 1 Bulkhead deck | 2 Considered as located above the bulkhead deck |
| 3 Ship's side | 4 Considered as located below the bulkhead deck |

Regulation 13.4

In cases where main and auxiliary propulsion machinery spaces, including boilers serving the needs for propulsion, are divided by watertight longitudinal bulkheads in order to comply with redundancy requirements (e.g., according to regulation 8-1.2), one watertight door in each watertight bulkhead may be permitted, as shown in the figure below.

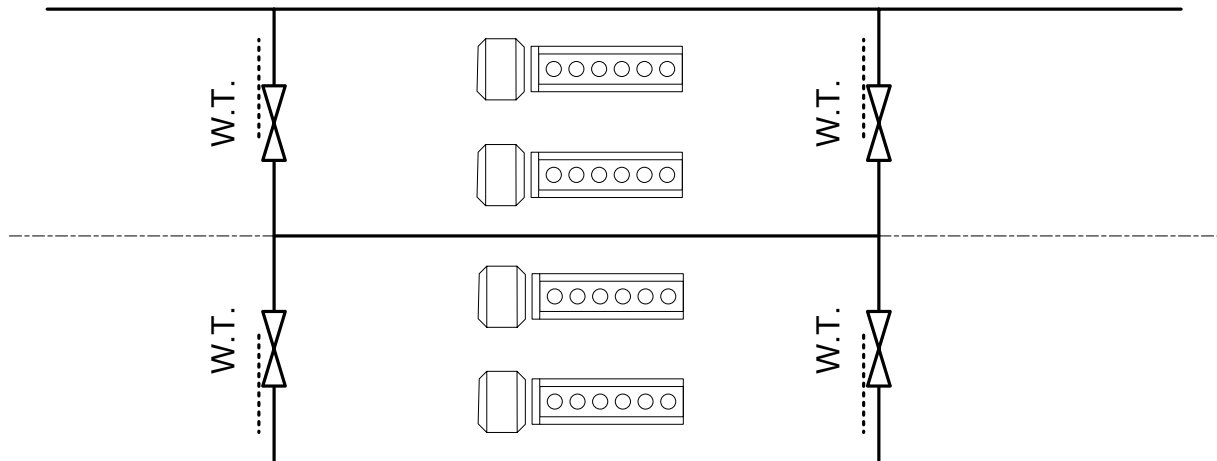

Regulation 13.7.6

The IEC standard referenced in the footnote (IEC publication 529, 1976) has been replaced by the newer standard IEC 60529:2003.

REGULATION 13-1– OPENINGS IN WATERTIGHT BULKHEADS AND INTERNAL DECKS IN CARGO SHIPS

Regulation 13-1.1

1 If the transverse watertight bulkheads in a region of the ship are carried to a higher deck than in the remainder of the ship, openings located in the bulkhead at the step may be considered as being located above the freeboard deck.

2 All openings in the shell plating below the upper deck throughout that region of the ship should be treated as being below the freeboard deck, similar to the bulkhead deck for passenger ships (see relevant figure under regulation 13 above), and the provisions of regulation 15 should be applied.

REGULATION 15 – OPENINGS IN THE SHELL PLATING BELOW THE BULKHEAD DECK OF PASSENGER SHIPS AND THE FREEBOARD DECK OF CARGO SHIPS

General – Steps in the bulkhead deck and freeboard deck

For the treatment of steps in the bulkhead deck of passenger ships see Explanatory Notes for regulation 13. For the treatment of steps in the freeboard deck of cargo ships see Explanatory Notes for regulation 13-1.

REGULATION 15-1– EXTERNAL OPENINGS IN CARGO SHIPS

Regulation 15-1.1

With regard to air-pipe closing devices, they should be considered weathertight closing devices (not watertight). This is consistent with their treatment in regulation 7-2.5.2.1. However, in the context of regulation 15-1, “external openings” are not intended to include air-pipe openings.

REGULATION 16 – CONSTRUCTION AND INITIAL TESTS OF WATERTIGHT DOORS, SIDESCUTTLES, ETC.

Regulation 16.2

1 Watertight doors should be tested by water pressure to a head of water measured from the lower edge of the door opening to the bulkhead deck or the freeboard deck, or to the most unfavourable final or intermediate waterplane during flooding, whichever is greater.

2 Large doors, hatches or ramps on passenger and cargo ships, of a design and size that would make pressure testing impracticable, may be exempted from regulation 16.2, provided it is demonstrated by calculations that the doors, hatches or ramps maintain watertightness at design pressure with a proper margin of resistance. Where such doors utilize gasket seals, a prototype pressure test to confirm that the compression of the gasket material is capable of accommodating any deflection, revealed by the structural analysis, should be carried out. After installation every such door, hatch or ramp should be tested by means of a hose test or equivalent.

Note: See Explanatory Notes for regulation 13 for additional information regarding the treatment of steps in the bulkhead deck of passenger ships. See Explanatory Notes for regulation 13-1 for additional information regarding the treatment of steps in the freeboard deck of cargo ships.

REGULATION 17 – INTERNAL WATERTIGHT INTEGRITY OF PASSENGER SHIPS ABOVE THE BULKHEAD DECK

General – Steps in the bulkhead deck

For the treatment of steps in the bulkhead deck of passenger ships see Explanatory Notes for regulation 13.

Regulation 17.1

Watertight sliding doors with reduced pressure head complying with the requirements of MSC/Circ.541, as may be amended, should be in line with regulation 7-2.5.2.1. These types of tested watertight sliding doors with reduced pressure head could be immersed during intermediate stages of flooding.

Regulation 17.3

These provisions regarding the open end of air pipes should be applied only to damages of longitudinal and transverse extent as defined in regulation 8.3 but limited to the bulkhead deck and involving tanks having their open end terminating within the superstructure.

APPENDIX

GUIDELINES FOR THE PREPARATION OF SUBDIVISION AND DAMAGE STABILITY CALCULATIONS

1 GENERAL

1.1 Purpose of the Guidelines

1.1.1 These Guidelines serve the purpose of simplifying the process of the damage stability analysis, as experience has shown that a systematic and complete presentation of the particulars results in considerable saving of time during the approval process.

1.1.2 A damage stability analysis serves the purpose to provide proof of the damage stability standard required for the respective ship type. At present, two different calculation methods, the deterministic concept and the probabilistic concept are applied.

1.2 Scope of analysis and documentation on board

1.2.1 The scope of subdivision and damage stability analysis is determined by the required damage stability standard and aims at providing the ship's master with clear intact stability requirements. In general, this is achieved by determining *KG*-respective *GM*-limit curves, containing the admissible stability values for the draught range to be covered.

1.2.2 Within the scope of the analysis thus defined, all potential or necessary damage conditions will be determined, taking into account the damage stability criteria, in order to obtain the required damage stability standard. Depending on the type and size of ship, this may involve a considerable amount of analyses.

1.2.3 Referring to SOLAS chapter II-1, regulation 19, the necessity to provide the crew with the relevant information regarding the subdivision of the ship is expressed, therefore plans should be provided and permanently exhibited for the guidance of the officer in charge. These plans should clearly show for each deck and hold the boundaries of the watertight compartments, the openings therein with means of closure and position of any controls thereof, and the arrangements for the correction of any list due to flooding. In addition, Damage Control Booklets containing the aforementioned information should be available.

2 DOCUMENTS FOR SUBMISSION

2.1 Presentation of documents

The documentation should begin with the following details: principal dimensions, ship type, designation of intact conditions, designation of damage conditions and pertinent damaged compartments, *KG*-respective *GM*-limit curve.

2.2 General documents

For the checking of the input data, the following should be submitted:

- .1 main dimensions;
- .2 lines plan, plotted or numerically;

- .3 hydrostatic data and cross curves of stability (including drawing of the buoyant hull);
- .4 definition of sub-compartments with moulded volumes, centres of gravity and permeability;
- .5 layout plan (watertight integrity plan) for the sub-compartments with all internal and external opening points including their connected sub-compartments, and particulars used in measuring the spaces, such as general arrangement plan and tank plan. The subdivision limits, longitudinal, transverse and vertical, should be included;
- .6 light service condition;
- .7 load line draught;
- .8 coordinates of opening points with their level of tightness (e.g., weathertight, unprotected);
- .9 watertight door location with pressure calculation;
- .10 side contour and wind profile;
- .11 cross and down flooding devices and the calculations thereof according to resolution MSC.245(83) with information about diameter, valves, pipe lengths and coordinates of inlet/outlet;
- .12 pipes in damaged area when the destruction of these pipes results in progressive flooding; and
- .13 damage extensions and definition of damage cases.

2.3 Special documents

The following documentation of results should be submitted.

2.3.1 Documentation

2.3.1.1 Initial data:

- .1 subdivision length L_s ;
- .2 initial draughts and the corresponding GM -values;
- .3 required subdivision index R ; and
- .4 attained subdivision index A with a summary table for all contributions for all damaged zones.

2.3.1.2 Results for each damage case which contributes to the index A :

- .1 draught, trim, heel, GM in damaged condition;
- .2 dimension of the damage with probabilistic values p , v and r ;
- .3 righting lever curve (including GZ_{max} and range) with factor of survivability s ;
- .4 critical weathertight and unprotected openings with their angle of immersion; and
- .5 details of sub-compartments with amount of in-flooded water/lost buoyancy with their centres of gravity.

2.3.1.3 In addition to the requirements in paragraph 2.3.1.2, particulars of non-contributing damages ($s_i = 0$ and $p_i > 0.00$) should also be submitted for passenger ships and ro-ro ships fitted with long lower holds including full details of the calculated factors.

2.3.2 Special consideration

For intermediate conditions, as stages before cross-flooding or before progressive flooding, an appropriate scope of the documentation covering the aforementioned items is needed in addition.

ANNEX 23**THEMATIC PRIORITIES FOR INCLUSION IN THE ITCP
COVERING THE 2010-2011 BIENNIUM**

- 1 Fostering the effective implementation of Conventions and other mandatory instruments, with particular emphasis on the SAR and STCW Conventions, and the ISM, IMDG and Casualty Investigation Codes, addressing the special needs of least developed countries (LDCs) and small island developing states (SIDS) and particular maritime needs of Africa.
- 2 Promoting SOLAS chapter XI-2 and the ISPS Code, the continued establishment and strengthening of effective ship and port facility security measures, and enhancing the safety and security of the ship/port interface, in accordance with the relevant IMO standards and recommendations.
- 3 Supporting maritime Administrations to strengthen their human resource capabilities in the discharge of their responsibilities as flag and port States, and promoting the global harmonization and co-ordination of port State control MoUs.
- 4 Supporting maritime Administrations to strengthen their services dedicated to safety of navigation and monitoring of maritime traffic.
- 5 Capacity-building for effective participation in the Voluntary IMO Member State Audit Scheme and effective compliance with the Code for the implementation of mandatory IMO instruments.
- 6 Promoting the acceptance and implementation of IMO instruments with particular emphasis on the 1993 Torremolinos Protocol and the 1995 STCW-F Convention as well as proactive safety measures relating to fishing vessels and their personnel.
- 7 Promoting and enhancing maritime safety aspects relating to non-Convention vessels, including small fishing vessels and domestic passenger ferries.
- 8 Supporting maritime training institutions and fellowship programmes.

ANNEX 24

WORK PROGRAMMES OF THE SUB-COMMITTEES

SUB-COMMITTEE ON BULK LIQUIDS AND GASES (BLG)

		Target completion date/number of sessions needed for completion	Reference
1	Evaluation of safety and pollution hazards of chemicals and preparation of consequential amendments <i>Strategic direction: 7.2 and 1.3</i> <i>High-level action: 7.2.2 and 1.3.3</i> <i>Planned output: 7.2.2.1 and 1.3.3.1</i>	Continuous	BLG 10/19, section 3; BLG 11/16, section 3
2	Casualty analysis (coordinated by FSI) <i>Strategic direction: 12.1</i> <i>High-level action: 12.1.2</i> <i>Planned output: 12.1.2.1 to .2</i>	Continuous	MSC 70/23, paragraphs 9.17 and 20.4; MSC 80/24, paragraph 21.6; BLG 12/17, section 9
3	Consideration of IACS unified interpretations <i>Strategic direction: 1.1</i> <i>High-level action: 1.1.2</i> <i>Planned output: 1.1.2.1</i>	Continuous	MSC 78/26, paragraph 22.12; BLG 12/17, section 10
H.1	Environmental and safety aspects of alternative tanker designs under MARPOL, Annex I, regulation 19 <i>Strategic direction: 7.2</i> <i>High-level action: 7.2.2</i> <i>Planned output: 7.2.2.1</i>		BLG 3/18, paragraph 15.7
.1	assessment of alternative tanker designs, if any (as necessary)	Continuous	BLG 1/20, section 16; BLG 4/18, paragraph 15.3

-
- Notes:**
- 1 “H” means a high priority item and “L” means a low priority item. However, within the high and low priority groups, items have not been listed in any order of priority.
 - 2 Items printed in bold letters have been selected for the provisional agenda for BLG 13.

Sub-Committee on Bulk Liquids and Gases (BLG) (continued)

		Target completion date/number of sessions needed for completion	Reference
H.2	Development of provisions for gas-fuelled ships (in cooperation with FP and DE) <i>Strategic direction:</i> 5.2 <i>High-level action:</i> 5.2.1 <i>Planned output:</i> 5.2.1.1	2009	MSC 78/26, paragraph 24.11; BLG 12/17, section 7
H.3	Development of guidelines and other documents for uniform implementation of the 2004 BWM Convention <i>Strategic direction:</i> 7.1 <i>High-level action:</i> 7.1.2 <i>Planned output:</i> 7.1.2.2 to .5	2010	MEPC 52/24, paragraph 2.21.6; BLG 12/17, section 5
H.4	Application of the requirements for the carriage of bio-fuels and bio-fuel blends <i>Strategic direction:</i> 7.2 <i>High-level action:</i> 7.2.2 <i>Planned output:</i> 7.2.2.1	2009	MEPC 55/23, paragraphs 19.4 and 19.5; BLG 12/17, section 4
H.5	Development of international measures for minimizing the transfer of invasive aquatic species through bio-fouling of ships <i>Strategic direction:</i> 7.1 <i>High-level action:</i> 7.1.1 <i>Planned output:</i> -	2010	MEPC 56/23, paragraph 19.12; BLG 12/17, section 11
H.6	Review of the Recommendation for material safety data sheets for MARPOL Annex I cargoes and marine fuel oils <i>Strategic direction:</i> 5.2 <i>High-level action:</i> 5.2.3 <i>Planned output:</i> 5.2.3.1	2009	BLG 11/16, paragraph 14.14; MSC 83/28, paragraph 25.8; BLG 12/17, section 12

Sub-Committee on Bulk Liquids and Gases (BLG) (continued)

		Target completion date/number of sessions needed for completion	Reference
H.7	Revision of the IGC Code (in cooperation with FP, DE, SLF and STW, as necessary) <i>Strategic direction:</i> 5.2 <i>High-level action:</i> 5.2.1 <i>Planned output:</i> -	2010	MSC 83/28, paragraph 25.7; BLG 12/17, section 13
H.8	Safety requirements for natural gas hydrate pellet carriers <i>Strategic direction:</i> 5.2 <i>High-level action:</i> 5.2.1 <i>Planned output:</i> -	2011	MSC 83/28, paragraph 25.6
H.9	Review of relevant non-mandatory instruments as a consequence of the amended MARPOL Annex VI and the NO_x Technical Code <i>Strategic direction:</i> 7.3 <i>High-level action:</i> 7.3.1 <i>Planned output:</i> 7.3.1.1	2010	BLG 12/17, paragraph 6.88.9
H.10	Amendments to MARPOL Annex I on the use and carriage of heavy grade oil on ships in the Antarctic area <i>Strategic direction:</i> 7.2 <i>High-level action:</i> 7.2.2 <i>Planned output:</i> -	2010	BLG 12/17, paragraph 16.12
H.11	Revision of the Recommendations for entering enclosed spaces aboard ships (co-ordinated by DSC) <i>Strategic direction:</i> 5.2 <i>High-level action:</i> 5.2.3 <i>Planned output:</i> -	2010*	MSC 85/26, paragraph 23.4

* To be included in the provisional agenda for BLG 14.

SUB-COMMITTEE ON DANGEROUS GOODS, SOLID CARGOES AND CONTAINERS (DSC)

		Target completion date/number of sessions needed for completion	Reference
1	Harmonization of the IMDG Code with the UN Recommendations on the Transport of Dangerous Goods <i>Strategic direction: 1.3</i> <i>High-level action: 1.3.5</i> <i>Planned output: 1.3.5.1</i>	Continuous	MSC 63/23, paragraph 10.6
2	Reports on incidents involving dangerous goods or marine pollutants in packaged form on board ships or in port areas <i>Strategic direction: 12.3</i> <i>High-level action: 12.3.1</i> <i>Planned output: -</i>	Continuous	CDG 45/22, section 11 and paragraph 20.2; DSC 13/20, section 6
3	Amendments to the IMSBC Code, including evaluation of properties of solid bulk cargoes <i>Strategic direction: 5.2</i> <i>High-level action: 5.2.3</i> <i>Planned output: -</i>	Continuous	BC 34/17, section 3; DSC 13/20, section 4
4	Casualty analysis (coordinated by FSI) <i>Strategic direction: 12.1</i> <i>High-level action: 12.1.2</i> <i>Planned output: 12.1.2.1 to .2</i>	Continuous	MSC 70/23, paragraphs 9.17 and 20.4; DSC 13/20, section 6
H.1	Amendment (35-10) to the IMDG Code and supplements <i>Strategic direction: 5.2</i> <i>High-level action: 5.2.3</i> <i>Planned output: 5.2.3.1</i>	2009	DSC 3/15, paragraph 12.6; DSC 13/20, section 3
H.2	Amendments to the CSS Code and associated recommendations <i>Strategic direction: 5.2</i> <i>High-level action: 5.2.3</i> <i>Planned output: 5.2.3.1</i>	2009	MSC 78/26, paragraph 24.15.3; DSC 13/20, section 8

Notes: 1 “H” means high priority item and “L” means a low priority item. However, within the high and low priority groups, items have not been listed in any order of priority.
2 Items printed in bold letters have been selected for the provisional agenda for DSC 14.

Sub-Committee on Dangerous Goods, Solid Cargoes and Containers (DSC) (continued)

		Target completion date/number of sessions needed for completion	Reference
H.3	Review of the BLU Code <i>Strategic direction:</i> 5.2 <i>High-level action:</i> 5.2.3 <i>Planned output:</i> -	2009	MSC 79/23, paragraph 20.7; DSC 13/20, section 7
H.4	Review of the Recommendations on the safe use of pesticides in ships <i>Strategic direction:</i> 5.2 <i>High-level action:</i> 5.2.3 <i>Planned output:</i> 5.2.3.2	2009	DSC 10/17, paragraph 4.23; DSC 13/20, section 9
H.5	Guidance on protective clothing <i>Strategic direction:</i> 5.2 <i>High-level action:</i> 5.2.3 <i>Planned output:</i> 5.2.3.2	2009	MSC 81/25, paragraph 23.8; DSC 13/20, section 10
H.6	Revision of the Code of Safe Practice for Ships Carrying Timber Deck Cargoes <i>Strategic direction:</i> 5.2 <i>High-level action:</i> 5.2.3 <i>Planned output:</i> -	2010	MSC 82/24, paragraph 21.11; DSC 13/20, section 11
H.7	Stowage of water-reactive materials (in cooperation with FP, as necessary) <i>Strategic direction:</i> 5.2 <i>High-level action:</i> 5.2.3 <i>Planned output:</i> -	2009	MSC 83/28, paragraph 25.12; DSC 13/20, section 13
H.8	Amendments to the International Convention for Safe Containers, 1972 and associated circulars <i>Strategic direction:</i> 5.2 <i>High-level action:</i> 5.2.3 <i>Planned output:</i> 5.2.3.1	2009	DSC 12/19, section 16; MSC 83/28, paragraph 25.13.1; DSC 13/20, section 14

Sub-Committee on Dangerous Goods, Solid Cargoes and Containers (DSC) (continued)

		Target completion date/number of sessions needed for completion	Reference
H.9	Review of the Guidelines for packing of cargo transport units <i>Strategic direction:</i> 5.2 <i>High-level action:</i> 5.2.3 <i>Planned output:</i> 5.2.3.2	2009	MSC 83/28, paragraph 25.13.2 DSC 13/20, section 15
H.10	Amendments to MARPOL Annex III* <i>Strategic direction:</i> 5.2 <i>High-level action:</i> 5.2.3 <i>Planned output:</i> -	2009	DSC 13/20, section 16
H.11	Revision of the Recommendations for entering enclosed spaces aboard ships (in co-operation with BLG, FP and STW) <i>Strategic direction:</i> 5.2 <i>High-level action:</i> 5.2.3 <i>Planned output:</i> -	2010	DSC 13/20, section 19 MSC 85/26, paragraph 23.7
L.1	Review of documentation requirements for dangerous goods in packaged form <i>Strategic direction:</i> 5.2 <i>High-level action:</i> 5.2.3 <i>Planned output:</i> 5.2.3.1	2009	MSC 84/24, paragraph 22.9
L.2	Consideration for the efficacy of Container Inspection Programme <i>Strategic direction:</i> 5.2 <i>High-level action:</i> 5.2.3 <i>Planned output:</i> 5.2.3.1	2010	MSC 84/24, paragraph 22.10; DSC 13/20, section 16

* Subject to the decision of MEPC 59.

SUB-COMMITTEE ON FIRE PROTECTION (FP)

		Target completion date/number of sessions needed for completion	Reference
1	Analysis of fire casualty records <i>Strategic direction: 12.1</i> <i>High-level action: 12.1.2</i> <i>Planned output: 12.1.2.1 to .2</i>	Continuous	MSC 75/24, paragraph 22.18; FP 52/21, section 15
2	Consideration of IACS unified interpretations <i>Strategic direction: 1.1</i> <i>High-level action: 1.1.2</i> <i>Planned output: 1.1.2.1</i>	Continuous	MSC 78/26, paragraph 22.12; FP 52/21, section 12
H.1	Performance testing and approval standards for fire safety systems <i>Strategic direction: 2</i> <i>High-level action: 2.1.1</i> <i>Planned output: 2.1.1.2</i>	2011	MSC 74/24, paragraph 21.12; FP 52/21, section 3; MSC 85/26, paragraph 23.11
H.2	Comprehensive review on the Fire Test Procedures Code <i>Strategic direction: 2</i> <i>High-level action: 2.1.1</i> <i>Planned output: 2.1.1.1</i>	2009	MSC 80/24, paragraph 21.11; FP 52/21, section 4
H.3	Development of provisions for gas-fuelled ships (coordinated by BLG) <i>Strategic direction: 5.2</i> <i>High-level action: 5.2.1</i> <i>Planned output: 5.2.1.1</i>	2009	MSC 78/26, paragraph 24.19; FP 52/21, section 11
H.4	Measures to prevent fires in engine-rooms and cargo pump-rooms <i>Strategic direction: 2</i> <i>High-level action: 2.1.1</i> <i>Planned output: 2.1.1.2</i>	2009	MSC 79/23, paragraph 20.11; FP 52/21, section 6

-
- Notes:** 1 “H” means a high priority item and “L” means a low priority item. However, within the high and low priority groups, items have not been listed in any order of priority.
2 Items printed in bold letters have been selected for the provisional agenda for FP 53.

Sub-Committee on Fire Protection (FP) (continued)

		Target completion date/number of sessions needed for completion	Reference
H.5	Fire resistance of ventilation ducts <i>Strategic direction:</i> 5.2 <i>High-level action:</i> 5.2.1 <i>Planned output:</i> 5.2.1.1	2009	MSC 81/25, paragraph 23.13; MSC 83/28, paragraph 25.22
H.6	Fixed hydrocarbon gas detection systems on double-hull oil tankers (in cooperation with BLG, as necessary) <i>Strategic direction:</i> 2 <i>High-level action:</i> 2.1.1 <i>Planned output:</i> 2.1.1.1	2010	MSC 82/24, paragraph 21.18; FP 52/21, section 13; MSC 84/24, paragraph 22.16
H.7	Clarification of SOLAS chapter II-2 requirements regarding interrelation between central control station and safety centre <i>Strategic direction:</i> 2 <i>High-level action:</i> 2.1.1 <i>Planned output:</i> 2.1.1.2	2009	MSC 82/24, paragraph 21.20; FP 52/21, section 14
H.8	Harmonization of the requirements for the location of entrances, air inlets and openings in the superstructures of tankers (in cooperation with BLG, as necessary) <i>Strategic direction:</i> 5.2 <i>High-level action:</i> 5.2.1 <i>Planned output:</i> -	2010	MSC 83/28, paragraph 25.24.2; FP 52/21, paragraph 16.1
H.9	Amendments to SOLAS chapter II-2 related to the releasing controls and means of escape for spaces protected by fixed carbon dioxide systems <i>Strategic direction:</i> 5.2 <i>High-level action:</i> 5.2.1 <i>Planned output:</i> -	2010	MSC 83/28, paragraph 25.24.1; FP 52/21, paragraph 16.1

Sub-Committee on Fire Protection (FP) (continued)

		Target completion date/number of sessions needed for completion	Reference
H.10	Guidelines for drainage systems in closed vehicle and ro-ro spaces and special category spaces (in cooperation with SLF) <i>Strategic direction:</i> 5.1 <i>High-level action:</i> 5.1.1 <i>Planned output:</i> 5.1.1.2	2009	MSC 83/28, paragraph 25.20; FP 52/21, paragraph 18.5
H.11	Review of fire protection requirements for on-deck cargo areas (in cooperation with DSC, as necessary) <i>Strategic direction:</i> 5.1 <i>High-level action:</i> 5.1.1 <i>Planned output:</i> -	2011	MSC 83/28, paragraph 25.21; FP 52/21, paragraph 16.1
H.12	Means of escape from machinery spaces <i>Strategic direction:</i> 5.2 <i>High-level action:</i> 5.2.1 <i>Planned output:</i> -	2010	MSC 83/28, paragraph 25.23; FP 52/21, paragraph 16.1
H.13	Measures to prevent explosions on oil and chemical tankers transporting low-flash point cargoes (in cooperation with BLG and DE, as necessary) <i>Strategic direction:</i> 5.2 <i>High-level action:</i> 5.2.3 <i>Planned output:</i> 5.2.3.4	2009	FP 51/19, paragraph 10.8; MSC 83/28, paragraph 9.26; FP 52/21, section 20
H.14	Recommendation on evacuation analysis for new and existing passenger ships <i>Strategic direction:</i> 5.1 <i>High-level action:</i> 5.1.1 <i>Planned output:</i> 5.1.1.1	2010	MSC 73/21, paragraph 4.16; MSC 83/28, paragraph 8.7; FP 52/21, section 19

Sub-Committee on Fire Protection (FP) (continued)

		Target completion date/number of sessions needed for completion	Reference
H.15	Explanatory notes for the application of the safe return to port requirements (in cooperation with DE and SLF, as necessary) <i>Strategic direction:</i> 5.1 <i>High-level action:</i> 5.1.1 <i>Planned output:</i> -	2010	MSC 84/24, paragraph 22.15
H.16	Safety provisions applicable to tenders operating from passenger ships (coordinated by DE) <i>Strategic direction:</i> 5.2 <i>High-level action:</i> 5.2.1 <i>Planned output:</i> -	3 sessions	MSC 84/24, paragraph 22.14
H.17	Fire integrity of bulkheads and decks of ro-ro spaces on passenger and cargo ships <i>Strategic direction:</i> 5 <i>High-level action:</i> 5.2.1 <i>Planned output:</i> -	2 sessions	MSC 85/26, paragraph 23.12
H.18	Requirements for ships carrying hydrogen and compressed natural gas vehicles <i>Strategic direction:</i> 2 <i>High-level action:</i> 2.1.1 <i>Planned output:</i> -	2 sessions	MSC 85/26, paragraph 23.13
H.19	Revision of the Recommendations for entering enclosed spaces aboard ships (co-ordinated by DSC) <i>Strategic direction:</i> 5.2 <i>High-level action:</i> 5.2.3 <i>Planned output:</i> -	2010*	MSC 85/26, paragraph 23.10
L.1	Smoke control and ventilation <i>Strategic direction:</i> 5.2 <i>High-level action:</i> 5.2.1 <i>Planned output:</i> -	2 sessions	FP 39/19, section 9; FP 46/16, section 4

* To be included in the provisional agenda for FP 54.

SUB-COMMITTEE ON FLAG STATE IMPLEMENTATION (FSI)

		Target completion date/number of sessions needed for completion	Reference
1	Mandatory reports under MARPOL <i>Strategic direction:</i> 2 <i>High-level action:</i> 2.1.1 <i>Planned output:</i> 2.1.1.6	Continuous	MSC 70/23, paragraph 20.12.1; MEPC 56/23, paragraph 14.4; FSI 16/18, section 4
2	Casualty statistics and investigations <i>Strategic direction:</i> 1.1/2/4/5.3/12.1/12.3 <i>High-level action:</i> 1.1.2/2.1.1/4.2.1/ 5.3.1/12.1.2/12.3.1 <i>Planned output:</i> 1.1.2.1/2.1.1.1/4.2.1.1/4.2.1.3/5.3.1.5/ 12.1.2.1/12.1.2.2/12.3.1.1	Continuous	MSC 68/23, paragraphs 7.16 to 7.24; FSI 16/18, section 6
3	Harmonization of port State control activities <i>Strategic direction:</i> 1.1/2/4/5.3/12.3 <i>High-level action:</i> 1.1.2/2.1.1/4.2.1/ 5.3.1/12.3.1 <i>Planned output:</i> 1.1.2.1/2.1.1.7/4.2.1.1/4.2.1.3/5.3.1.2/ 5.3.1.3/5.3.1.4/5.3.1.5/12.3.1.2	Continuous	MSC 71/23, paragraph 20.16; MSC 80/24, paragraph 21.16; FSI 16/18, section 7
4	Responsibilities of Governments and measures to encourage flag State compliance <i>Strategic direction:</i> 2/4/5.3 <i>High-level action:</i> 2.1.1/4.2.1/5.3.1 <i>Planned output:</i> 2.1.1.5/4.2.1.2/5.3.1.5	Continuous	MSC 68/23, paragraphs 7.2 to 7.8; FSI 16/18, section 3

-
- Notes:**
- 1 “H” means a high priority item and “L” means a low priority item. However, within the high and low priority groups, items have not been listed in any order of priority.
 - 2 Items printed in bold letters have been selected for the provisional agenda for FSI 17.

Sub-Committee on Flag State Implementation (FSI) (continued)

		Target completion date/number of sessions needed for completion	Reference
5	Comprehensive analysis of difficulties encountered in the implementation of IMO instruments <i>Strategic direction: 2</i> <i>High-level action: 2.1.1</i> <i>Planned output: 2.1.1.5</i>	Continuous	MSC 69/22, paragraph 20.28; FSI 8/19, paragraph 4.3; FSI 16/18, section 10
6	Review of the Survey Guidelines under the HSSC <i>Strategic direction: 5.2</i> <i>High-level action: 5.2.1</i> <i>Planned output: 5.2.1.2</i>	Continuous	MSC 72/23, paragraph 21.27; FSI 16/18, section 11
7	Consideration of IACS unified interpretations <i>Strategic direction: 1.1</i> <i>High-level action: 1.1.2</i> <i>Planned output: 1.1.2.1</i>	Continuous	MSC 78/26, paragraph 22.12; FSI 16/18, section 12
8	Review of the Code for the Implementation of Mandatory IMO Instruments <i>Strategic direction: 2</i> <i>High-level action: 2.2.1</i> <i>Planned output: 2.2.1.2</i>	Continuous	MSC 83/28, paragraph 25.27; FSI 16/18, section 14
H.1	PSC guidelines on seafarers' working hours and PSC guidelines in relation to the Maritime Labour Convention, 2006 <i>Strategic direction: 1.1</i> <i>High-level action: 1.1.2</i> <i>Planned output: 1.1.2.1</i>	2009	MSC 70/23, paragraph 20.12.3; FSI 16/18, section 9
H.2	Development of guidelines on port State control under the 2004 BWM Convention <i>Strategic direction: 2/5.3</i> <i>High-level action: 2.1.1/5.3.1</i> <i>Planned output: 2.1.1.2/5.3.1.2</i>	2010	MEPC 52/24, paragraph 2.21.2; FSI 16/18, section 8

Sub-Committee on Flag State Implementation (FSI) (continued)

		Target completion date/number of sessions needed for completion	Reference
H.3	Port reception facilities-related issues <i>Strategic direction:</i> 7.1 <i>High-level action:</i> 7.1.3 <i>Planned output:</i> 7.1.3.1/7.1.3.2	2010	MEPC 53/24, paragraph 9.7; FSI 16/18, section 5
H.4	Development of a Code for Recognized Organizations <i>Strategic direction:</i> 2 <i>High-level action:</i> 2.1.1 <i>Planned output:</i> 2.1.1.1	2010	MSC 84/24, paragraph 22.27; FSI 16/18, section 15
H.5	Measures to protect the safety of persons rescued at sea <i>Strategic direction:</i> 5.1 <i>High-level action:</i> 5.1.2 <i>Planned output:</i> -	2010	MSC 84/24, section 22; FSI 16/18, section 15
H.6	Code of conduct during demonstrations/campaigns against ships on high seas (coordinated by NAV) <i>Strategic direction:</i> 5.2 <i>High-level action:</i> 5.2.4 <i>Planned output:</i> 5.2.4.2	2009	MSC 82/24, section 22; MSC 85/26, paragraph 23.20

SUB-COMMITTEE ON RADIOCOMMUNICATIONS AND SEARCH AND RESCUE (COMSAR)

		Target completion date/number of sessions needed for completion	Reference
1	Global Maritime Distress and Safety System (GMDSS)		
.1	matters relating to the GMDSS Master Plan <i>Strategic direction: 5.2</i> <i>High-level action: 5.2.5</i> <i>Planned output: 5.2.5.2</i>	Continuous	COMSAR 12/15 paragraphs 3.1 to 3.7 and 3.23 to 3.30
2	Promulgation of maritime safety information (MSI) (in cooperation with ITU, IHO, WMO and IMSO)		
.1	operational and technical coordination provisions of maritime safety information (MSI) services, including review of the related documents <i>Strategic direction: 5.2</i> <i>High-level action: 5.2.5</i> <i>Planned output: 5.2.5.1</i>	Continuous	COMSAR 12/15 paragraphs 3.1 to 3.7 and 3.23 to 3.30
3	ITU World Radiocommunication Conference matters <i>Strategic direction: 1.1</i> <i>High-level action: 1.1.2</i> <i>Planned output: 1.1.2.2</i>	Continuous	COMSAR 12/15, paragraphs 4.11 to 4.19 and 4.28 to 4.35
4	Radiocommunication ITU-R Study Group matters <i>Strategic direction: 1.1</i> <i>High-level action: 1.1.2</i> <i>Planned output: 1.1.2.2</i>	Continuous	COMSAR 12/15 paragraphs 4.1 to 4.10 and 4.22 to 4.27

Notes:

- 1 “H” means a high priority item and “L” means a low priority item. However, within the high and low priority groups, items have not been listed in any order of priority.
- 2 Items printed in bold letters have been selected for the provisional agenda for COMSAR 13.

Sub-Committee on Radiocommunications and Search and Rescue (COMSAR) (continued)

		Target completion date/number of sessions needed for completion	Reference
5	Satellite services (Inmarsat and COSPAS-SARSAT) <i>Strategic direction:</i> 5.2 <i>High-level action:</i> 5.2.5 <i>Planned output:</i> 5.2.5.4	Continuous	COMSAR 12/15, section 5
6	Matters concerning search and rescue, including those related to the 1979 SAR Conference and the implementation of the GMDSS		
.1	harmonization of aeronautical and maritime search and rescue procedures, including SAR training matters <i>Strategic direction:</i> 2 <i>High-level action:</i> 2.3.1 <i>Planned output:</i> 1.3.5.2/ 2.3.1.5	2009	COMSAR 12/15, paragraphs 6.1 to 6.15, 6.65 to 6.75 and 6.91 to 6.92
.2	plan for the provision of maritime SAR services, including procedures for routing distress information in the GMDSS <i>Strategic direction:</i> 2 <i>High-level action:</i> 2.3.1 <i>Planned output:</i> 2.3.1.1/ 2.3.1.2	Continuous	COMSAR 12/15, paragraphs 6.16 to 6.59 and 6.76 to 6.90
.3	revision of the IAMSAR Manual <i>Strategic direction:</i> 1.3 <i>High-level action:</i> 1.3.5 <i>Planned output:</i> 1.3.5.2	Continuous	MSC 71/23, paragraph 20.2; COMSAR 12/15, section 8
7	Casualty analysis (coordinated by FSI) <i>Strategic direction:</i> 12.1 <i>High-level action:</i> 12.1.2 <i>Planned output:</i> 12.1.2.1 to .2	Continuous	MSC 70/23, paragraphs 9.17 and 20.4; MSC 78/26, paragraph 24.8

Sub-Committee on Radiocommunications and Search and Rescue (COMSAR) (continued)

		Target completion date/number of sessions needed for completion	Reference
H.1	Developments in maritime radiocommunication systems and technology <i>Strategic direction:</i> 5.2 <i>High-level action:</i> 5.2.5 <i>Planned output:</i> -	2009	MSC 74/24, paragraph 21.25.1; COMSAR 12/15, section 7
H.2	Development of procedures for updating shipborne navigation and communication equipment (coordinated by NAV) <i>Strategic direction:</i> 5.2 <i>High-level action:</i> 5.2.5 <i>Planned output:</i> -	2010	MSC 83/28, paragraph 25.30
H.3	Measures to protect the safety of persons rescued at sea <i>Strategic direction:</i> 5.1 <i>High-level action:</i> 5.1.2 <i>Planned output:</i> -	2010	MSC 84/24, paragraph 22.36
H.4	Safety provisions applicable to tenders operating from passenger ships (coordinated by DE) <i>Strategic direction:</i> 5.2 <i>High-level action:</i> 5.2.1 <i>Planned output:</i> -	3 sessions	MSC 84/24, paragraph 22.35
H.5	Development of an e-navigation strategy implementation plan (co-ordinated by NAV) <i>Strategic direction:</i> 5.2 <i>High-level action:</i> 5.2.4 <i>Planned output:</i> -	4 sessions	MSC 85/26, paragraph 23.22

SUB-COMMITTEE ON SAFETY OF NAVIGATION (NAV)

		Target completion date/number of sessions needed for completion	Reference
1	Routeing of ships, ship reporting and related matters <i>Strategic direction:</i> 5.2 <i>High-level action:</i> 5.2.4 <i>Planned output:</i> 5.2.4.1	Continuous	MSC 72/23, paragraphs 10.69 to 10.71, 20.41 and 20.42; NAV 54/25, section 3
2	Casualty analysis (coordinated by FSI) <i>Strategic direction:</i> 12.1 <i>High-level action:</i> 12.1.2 <i>Planned output:</i> 12.1.2.1 to .2	Continuous	MSC 70/23, paragraphs 9.17 and 20.4; NAV 54/25, section 20
3	Consideration of IACS unified interpretations <i>Strategic direction:</i> 1.1 <i>High-level action:</i> 1.1.2 <i>Planned output:</i> 1.1.2.1	Continuous	MSC 78/26, paragraph 22.12; NAV 54/25, section 21
H.1	ITU matters <i>Strategic direction:</i> 5.2 <i>High-level action:</i> 5.2.4 <i>Planned output:</i> -	2009	MSC 69/22, paragraphs 5.69 and 5.70; NAV 54/25, section 9
.1	Radiocommunication ITU-R Study Group matters	2009	
H.2	Development of guidelines for IBS, including performance standards for bridge alert management <i>Strategic direction:</i> 5.2 <i>High-level action:</i> 5.2.4 <i>Planned output:</i> 5.2.4.2	2009	MSC 78/26, paragraph 24.30; NAV 54/25, section 4
H.3	Development of an e-navigation strategy implementation plan (in cooperation with COMSAR and STW) <i>Strategic direction:</i> 5.2 <i>High-level action:</i> 5.2.4 <i>Planned output:</i> 5.2.4.4	2012	MSC 81/25, paragraphs 23.34 to 23.37; NAV 54/25, section 13

- Notes:**
- 1 “H” means a high priority item and “L” means a low priority item. However, within the high and low priority groups, items have not been listed in any order of priority.
 - 2 Items printed in bold letters have been selected for the provisional agenda for NAV 55.

Sub-Committee on Safety of Navigation (NAV) (continued)

		Target completion date/number of sessions needed for completion	Reference
H.4	Guidelines on the layout and ergonomic design of safety centres on passenger ships <i>Strategic direction:</i> 5.2 <i>High-level action:</i> 5.2.4 <i>Planned output:</i> 5.2.4.2	2009	MSC 81/25, paragraph 23.42; NAV 54/25, section 16
H.5	Code of conduct during demonstrations/campaigns against ships on high seas (in cooperation with FSI) <i>Strategic direction:</i> 5.2 <i>High-level action:</i> 5.2.4 <i>Planned output:</i> 5.2.4.2	2009	MSC 82/24, paragraph 21.36; NAV 54/25, section 10
H.6	Measures to minimize incorrect data transmissions by AIS equipment (in cooperation with FSI and COMSAR, as necessary) <i>Strategic direction:</i> 5.2 <i>High-level action:</i> 5.2.4 <i>Planned output:</i> 5.2.4.2	2009	MSC 82/24, paragraph 21.38; NAV 54/25, section 11
H.7	Review of vague expressions in SOLAS regulation V/22 <i>Strategic direction:</i> 5.2 <i>High-level action:</i> 5.2.4 <i>Planned output:</i> 5.2.4.2	2009	MSC 82/24, paragraphs 21.39 to 21.40; NAV 54/25, section 17
H.8	Revision of the Guidance on the application of AIS binary messages <i>Strategic direction:</i> 5.2 <i>High-level action:</i> 5.2.4 <i>Planned output:</i> 5.2.4.2	2009	MSC 82/24, paragraph 21.41; NAV 54/25, section 18
H.9	Improved safety of pilot transfer arrangements (in cooperation with DE) <i>Strategic direction:</i> 5.2 <i>High-level action:</i> 5.2.4 <i>Planned output:</i> 5.2.4.2	2009	MSC 82/24, paragraph 21.42; NAV 54/25, section 19

Sub-Committee on Safety of Navigation (NAV) (continued)

		Target completion date/number of sessions needed for completion	Reference
H.10	Amendments to the Performance standards for VDR and S-VDR <i>Strategic direction: 5.2</i> <i>High-level action: 5.2.4</i> <i>Planned output: -</i>	2011	MSC 83/28, paragraph 25.34 MSC 84/24, paragraph 22.43
H.11	Development of procedures for updating shipborne navigation and communication equipment (in cooperation with COMSAR) <i>Strategic direction: 5.2</i> <i>High-level action: 5.2.4</i> <i>Planned output: -</i>	2010	MSC 83/28, paragraph 25.33
H.12	Safety provisions applicable to tenders operating from passenger ships (coordinated by DE) <i>Strategic direction: 5.2</i> <i>High-level action: 5.2.4</i> <i>Planned output: -</i>	3 sessions	MSC 84/24, paragraph 22.40
H.13	Guidelines for consideration of requests for safety zones larger than 500 metres around artificial islands, installations and structures in the EEZ <i>Strategic direction: 5.2</i> <i>High-level action: 5.2.4</i> <i>Planned output: -</i>	2010	MSC 84/24, paragraph 22.41

SUB-COMMITTEE ON SHIP DESIGN AND EQUIPMENT (DE)

		Target completion date/number of sessions needed for completion	Reference
1	Casualty analysis (coordinated by FSI) <i>Strategic direction:</i> 12.1 <i>High-level action:</i> 12.1.2 <i>Planned output:</i> 12.1.2.1 to .2	Continuous	MSC 70/23, paragraphs 9.17 and 20.4; DE 50/27, section 17
2	Consideration of IACS unified interpretations <i>Strategic direction:</i> 1.1 <i>High-level action:</i> 1.1.2 <i>Planned output:</i> 1.1.2.1	Continuous	MSC 78/26, paragraph 22.12; DE 51/28, section 22
H.1	Amendments to resolution A.744(18) <i>Strategic direction:</i> 5.2 <i>High-level action:</i> 5.2.1 <i>Planned output:</i> 5.2.1.1	2009	DE 45/27, paragraphs 7.18 and 7.19; DE 51/28, section 3
H.2	Measures to prevent accidents with lifeboats (in cooperation with FSI, NAV and STW) <i>Strategic direction:</i> 5.1 <i>High-level action:</i> 5.1.2 <i>Planned output:</i> 5.1.2.1	2010	MSC 74/24, paragraph 21.34; DE 51/28, section 8
H.3	Compatibility of life-saving appliances <i>Strategic direction:</i> 5.1 <i>High-level action:</i> 5.1.2 <i>Planned output:</i> 5.1.2.2	2009	DE 47/15, paragraph 5.3; MSC 78/26, paragraph 24.37.1; DE 51/28, section 9
H.4	Development of provisions for gas-fuelled ships (coordinated by BLG) <i>Strategic direction:</i> 5.2 <i>High-level action:</i> 5.2.1 <i>Planned output:</i> 5.2.1.1	2 sessions	MSC 78/26, paragraph 24.39; DE 51/28, section 4

- Notes:**
- 1 “H” means a high priority item and “L” means a low priority item. However, within the high and low priority groups, items have not been listed in any order of priority.
 - 2 Items printed in bold letters have been selected for the provisional agenda for DE 52.

Sub-Committee on Ship Design and Equipment (DE) (continued)

		Target completion date/number of sessions needed for completion	Reference
H.5	Test standards for extended service intervals of inflatable liferafts <i>Strategic direction: 5.1</i> <i>High-level action: 5.1.2</i> <i>Planned output: 5.1.2.3</i>	2009	MSC 78/26, paragraph 24.41; DE 51/28, section 10
H.6	Amendments to the Guidelines for ships operating in Arctic ice-covered waters (in cooperation with SLF, as necessary) <i>Strategic direction: 5.2</i> <i>High-level action: 5.2.1</i> <i>Planned output: 5.2.1.2</i>	2010	MSC 79/23, paragraph 8.25; DE 51/28, section 11
H.7	Revision of the Code on Alarms and Indicators (in cooperation with appropriate sub-committees, as necessary) <i>Strategic direction: 2</i> <i>High-level action: 2.1.1</i> <i>Planned output: 2.1.1.2</i>	2009	MSC 79/23, paragraph 20.28; DE 51/28, section 6
H.8	Amendments to the MODU Code <i>Strategic direction: 2</i> <i>High-level action: 2.1.1</i> <i>Planned output: 2.1.1.2</i>	2009	MSC 79/23, paragraph 22.51; DE 51/28, section 7
H.9	Guidelines for uniform operating limitations of high-speed craft (in cooperation with COMSAR, NAV and SLF) <i>Strategic direction: 5.2</i> <i>High-level action: 5.2.1</i> <i>Planned output: 5.2.1.2</i>	2009	MSC 81/25, paragraph 23.45; DE 51/28, section 13
H.10	Guidelines for maintenance and repair of protective coatings <i>Strategic direction: 2</i> <i>High-level action: 2.1.1</i> <i>Planned output: 2.1.1.2</i>	2009	MSC 81/25, paragraph 23.48.1; DE 51/28, section 14

Sub-Committee on Ship Design and Equipment (DE) (continued)

		Target completion date/number of sessions needed for completion	Reference
H.11	Performance standards for recovery systems <i>Strategic direction:</i> 5.1 <i>High-level action:</i> 5.1.1 <i>Planned output:</i> 5.1.1.1	2010	MSC 81/25, paragraph 23.49.1; DE 51/28, section 16
H.12	Guidance to ensure consistent policy for determining the need for watertight doors to remain open during navigation <i>Strategic direction:</i> 2 <i>High-level action:</i> 2.1.1 <i>Planned output:</i> 2.1.1.2	2009	SLF 49/17, paragraph 3.11; MSC 82/24, paragraph 21.47; DE 51/28, section 26
H.13	Development of a new framework of requirements for life-saving appliances (in cooperation with FP and COMSAR, as necessary) <i>Strategic direction:</i> 5 <i>High-level action:</i> 5.1.2 <i>Planned output:</i> -	2012	MSC 82/24, paragraph 21.49
H.14	Improved safety of pilot transfer arrangements (coordinated by NAV) <i>Strategic direction:</i> 5.2 <i>High-level action:</i> 5.2.4 <i>Planned output:</i> 5.2.4.2	2 sessions	MSC 82/24, paragraph 21.50
H.15	Cargo oil tank coating and corrosion protection <i>Strategic direction:</i> 5.2 <i>High-level action:</i> 5.2.1 <i>Planned output:</i> -	2009	MSC 82/24, paragraphs 21.51 and 23.12; DE 51/28, section 19

Sub-Committee on Ship Design and Equipment (DE) (continued)

		Target completion date/number of sessions needed for completion	Reference
H.16	Development of safety objectives and functional requirements of the Guidelines on alternative design and arrangements for SOLAS chapters II-1 and III <i>Strategic direction: 5.2</i> <i>High-level action: 5.2.1</i> <i>Planned output: -</i>	3 sessions	MSC 82/24, paragraphs 3.92 and 21.52
H.17	Protection against noise on board ships <i>Strategic direction: 5.2</i> <i>High-level action: 5.2.1</i> <i>Planned output: -</i>	2 sessions	MSC 83/28, paragraph 25.41
H.18	Thermal performance of immersion suits <i>Strategic direction: 5.1</i> <i>High-level action: 5.1.2</i> <i>Planned output: -</i>	2 sessions	MSC 84/24, paragraph 22.48
H.19	Amendments to the Revised recommendation on testing of life-saving appliances <i>Strategic direction: 5.1</i> <i>High-level action: 5.1.2</i> <i>Planned output: -</i>	2 sessions	MSC 84/24, paragraph 22.49
H.20	Safety provisions applicable to tenders operating from passenger ships (in cooperation with FP, COMSAR, NAV, SLF and STW) <i>Strategic direction: 5.2</i> <i>High-level action: 5.2.1</i> <i>Planned output: -</i>	3 sessions	MSC 84/24, paragraph 22.50

Sub-Committee on Ship Design and Equipment (DE) (continued)

		Target completion date/number of sessions needed for completion	Reference
H.21	Alternative arrangements for the bottom inspection requirements for passenger ships other than ro-ro passenger ships <i>Strategic direction:</i> 5.2 <i>High-level action:</i> 5.2.1 <i>Planned output:</i> -	1 session	MSC 84/24, paragraph 22.52
H.22	Classification of offshore industry vessels and consideration of the need for a code for offshore construction support vessels <i>Strategic direction:</i> 5.2 <i>High-level action:</i> 5.2.1 <i>Planned output:</i> -	2 sessions	MSC 85/26, paragraph 23.27
H.23	Interpretation on application of SOLAS, MARPOL and Load Line requirements for major conversions of oil tankers <i>Strategic direction:</i> 2 <i>High-level action:</i> 2.1.1 <i>Planned output:</i> 2.1.1.2/2.1.1.4	2 sessions	MSC 85/26, paragraph 23.28
L.1	Revision of resolution A.760(18) <i>Strategic direction:</i> 5.2 <i>High-level action:</i> 5.2.1 <i>Planned output:</i> 5.2.1.2	2010	DE 46/32, paragraph 31.23; DE 51/28, section 12
L.2	Free-fall lifeboats with float-free capabilities <i>Strategic direction:</i> 5.1 <i>High-level action:</i> 5.1.2 <i>Planned output:</i> -	1 session	MSC 76/23, paragraphs 20.41.3 and 20.48; DE 47/25, paragraph 22.6
L.3	Guidelines on equivalent methods to reduce on-board NO _x emissions <i>Strategic direction:</i> 7 <i>High-level action:</i> 7.3.1 <i>Planned output:</i> -	2 sessions	MEPC 41/20, paragraph 8.22.1; BLG 10/19, paragraph 12.3; MEPC 55/23, paragraph 19.9

Sub-Committee on Ship Design and Equipment (DE) (continued)

		Target completion date/number of sessions needed for completion	Reference
L.4	Performance standards for protective coatings <i>Strategic direction:</i> 2 <i>High-level action:</i> 2.1.1 <i>Planned output:</i> 2.1.1.2	2 sessions	MSC 76/23, paragraphs 20.41.2 and 20.48; DE 50/27, section 4
	.1 mandatory application of the Performance standard for protective coatings for void spaces on bulk carriers and oil tankers	2 sessions	
	.2 performance standard for protective coatings for void spaces on all types of ships	2 sessions	

SUB-COMMITTEE ON STABILITY AND LOAD LINES AND ON FISHING VESSELS SAFETY (SLF)

		Target completion date/number of sessions needed for completion	Reference
1	Consideration of IACS unified interpretations <i>Strategic direction: 1.1</i> <i>High-level action: 1.1.2</i> <i>Planned output: 1.1.2.1</i>	Continuous	MSC 78/26, paragraph 22.12; SLF 51/17, section 9
H.1	Safety of small fishing vessels (in cooperation with DE, COMSAR, FP, NAV and STW, as necessary) <i>Strategic direction: 5.2</i> <i>High-level action: 5.2.1</i> <i>Planned output: 5.2.1.2</i>	2010	MSC 79/23, paragraphs 11.15 and 20.32; MSC 83/28, paragraph 25.53; SLF 51/17, section 14
H.2	Development of new generation intact stability criteria <i>Strategic direction: 5.2</i> <i>High-level action: 5.2.1</i> <i>Planned output: -</i>	2010	SLF 51/17, section 14; MSC 85/26, paragraph 12.7
H.3	Development of options to improve effect on ship design and safety of the 1969 TM Convention <i>Strategic direction: 2.1</i> <i>High-level action: 2.1.1</i> <i>Planned output: 2.1.1.2</i>	2011	MSC 81/25, paragraph 23.53; SLF 51/17, section 14; MSC 85/26, paragraphs 23.33 and 23.34
H.4	Time-dependent survivability of passenger ships in damaged condition <i>Strategic direction: 5.1</i> <i>High-level action: 5.1.1</i> <i>Planned output: 5.1.1.1</i>	2011	MSC 81/25, paragraph 23.54; SLF 51/17, section 14

-
- Notes:**
- 1 “H” means a high priority item and “L” means a low priority item. However, within the high and low priority groups, items have not been listed in any order of priority.
 - 2 Items printed in bold letters have been selected for inclusion in the provisional agenda for SLF 52.

Sub-Committee on Stability and Load Lines and on Fishing Vessels Safety (SLF) (continued)

		Target completion date/number of sessions needed for completion	Reference
H.5	Guidance on the impact of open watertight doors on existing and new ship survivability <i>Strategic direction: 2.1</i> <i>High-level action: 2.1.1</i> <i>Planned output: 2.1.1.2</i>	2010	SLF 49/17, section 3; MSC 82/24, paragraph 21.56; SLF 51/17, section 14
H.6	Stability and sea-keeping characteristics of damaged passenger ships in a seaway when returning to port by own power or under tow <i>Strategic direction: 5.1</i> <i>High-level action: 5.1.1</i> <i>Planned output: 5.1.1.1</i>	2011	MSC 82/24, paragraph 21.57; SLF 51/17, section 14
H.7	Guidelines for verification of damage stability requirements for tankers and bulk carriers (in cooperation with DE and STW, as necessary) <i>Strategic direction: 2.1</i> <i>High-level action: 2.1.1</i> <i>Planned output: 2.1.1.2</i>	2010	MSC 83/28, paragraphs 25.50 to 25.52; SLF 51/17, section 14; MSC 85/26, paragraphs 23.36 to 23.40
H.8	Safety provisions applicable to tenders operating from passenger ships (coordinated by DE) <i>Strategic direction: 5.2</i> <i>High-level action: 5.2.1</i> <i>Planned output: -</i>	2012	MSC 84/24, paragraph 22.57; SLF 51/17, section 14
H.9	Damage stability regulations for ro-ro passenger ships <i>Strategic direction: 5.1</i> <i>High-level action: 5.1.1</i> <i>Planned output: -</i>	2011	MSC 84/24, paragraph 22.59; SLF 51/17, section 14

Sub-Committee on Stability and Load Lines and on Fishing Vessels Safety (SLF) (continued)

		Target completion date/number of sessions needed for completion	Reference
H.10	Development of an agreement on the implementation of the 1993 Torremolinos Protocol (in cooperation with appropriate sub-committees, as necessary) <i>Strategic direction:</i> 5.2 <i>High-level action:</i> 5.2.1 <i>Planned output:</i> 5.2.1.4	2011	MSC 84/24, paragraph 22.62; SLF 51/17, section 14
H.11	Revision of SOLAS chapter II-1 subdivision and damage stability regulations <i>Strategic direction:</i> 5.2 <i>High-level action:</i> 5.2.1 <i>Planned output:</i> -	2 sessions	SLF 51/17, section 14; MSC 85/26, paragraph 23.35
H.12	Subdivision standards for cargo ships <i>Strategic direction:</i> 5.2 <i>High-level action:</i> 5.2.1 <i>Planned output:</i> -	2011	MSC 85/26, paragraph 23.32

SUB-COMMITTEE ON STANDARDS OF TRAINING AND WATCHKEEPING (STW)

		Target completion date/number of sessions needed for completion	Reference
1	Validation of model training courses <i>Strategic direction:</i> 5.2 <i>High-level action:</i> 5.2.2 <i>Planned output:</i> -	Continuous	STW 31/17, paragraph 14.4; STW 39/12, section 3
2	Casualty analysis (coordinated by FSI) <i>Strategic direction:</i> 12.1 <i>High-level action:</i> 12.1.2 <i>Planned output:</i> 12.1.2.1 to .2	Continuous	MSC 77/26, paragraphs 18.10 and 23.40.2; STW 39/12, section 10
H.1	Unlawful practices associated with certificates of competency <i>Strategic direction:</i> 5.2 <i>High-level action:</i> 5.2.1 <i>Planned output:</i> -	Continuous	MSC 71/23, paragraph 20.55.2; STW 39/12, section 4
H.2	Measures to enhance maritime security <i>Strategic direction:</i> 6 <i>High-level action:</i> 6.3.2 <i>Planned output:</i> 6.3.2.1	2010	MSC 75/24, paragraphs 22.9 and 22.45; STW 38/17, section 6
H.3	Comprehensive review of the STCW Convention and Code <i>Strategic direction:</i> 5 <i>High-level action:</i> 5.2.2 <i>Planned output:</i> 5.2.2.1	2010	STW 37/18, section 15; MSC 81/25, paragraphs 23.57.2, 23.40.2, 23.62 and 23.63; STW 39/12, section 7; MSC 85/26, paragraph 23.46
.1	chapter I of the STCW Convention and Code		
.2	chapter II of the STCW Convention and Code		
.3	chapter III of the STCW Convention and Code		
.4	chapter IV of the STCW Convention and Code		

-
- Notes:**
- 1 “H” means high priority item and “L” means a low priority item. However, within the high and low priority groups, items have not been listed in any order of priority.
 - 2 Items printed in bold letters have been selected for the provisional agenda for STW 40.

Sub-Committee on Standards of Training and Watchkeeping (STW) (continued)

		Target completion date/number of sessions needed for completion	Reference
.5	chapter V of the STCW Convention and Code		
.6	chapter VI of the STCW Convention and Code		
.7	chapter VII of the STCW Convention and Code		
.8	chapter VIII of the STCW Convention and Code		
H.4	Review of the principles for establishing the safe manning level of ships (in cooperation with NAV) <i>Strategic direction:</i> 5 <i>High-level action:</i> 5.2.2 <i>Planned output:</i> 5.2.2.2	2010	MSC 81/25, paragraphs 23.58 to 23.60; STW 39/12, section 8
H.5	Development of training standards for recovery systems <i>Strategic direction:</i> 5.1 <i>High-level action:</i> 5.1.2 <i>Planned output:</i> -	2 sessions	MSC 81/25, paragraph 23.64
H.6	Training for seafarer safety representatives <i>Strategic direction:</i> 5.2 <i>High-level action:</i> 5.2.2 <i>Planned output:</i> -	2009	MSC 82/24, paragraph 21.23; STW 39/12, section 5
H.7	Safety provisions applicable to tenders operating from passenger ships (coordinated by DE) <i>Strategic direction:</i> 12 <i>High-level action:</i> 12.1.2 <i>Planned output:</i> 12.1.2.1	3 sessions	MSC 84/24, paragraph 22.66
H.8	Mandatory requirements for determining safe manning (in cooperation with NAV, as necessary) <i>Strategic direction:</i> 12 <i>High-level action:</i> 12.1.2 <i>Planned output:</i> -	2010	MSC 84/24, paragraph 22.68

Sub-Committee on Standards of Training and Watchkeeping (STW) (continued)

		Target completion date/number of sessions needed for completion	Reference
H.9	Revision of the Recommendations for entering enclosed spaces aboard ships (coordinated by DSC) <i>Strategic direction:</i> 5.2 <i>High-level action:</i> 5.2.3 <i>Planned output:</i> -	2010*	MSC 85/26, paragraph 23.44
H.10	Development of an e-navigation strategy implementation plan (coordinated by NAV) <i>Strategic direction:</i> 5.2 <i>High-level action:</i> 5.2.4 <i>Planned output:</i> -	4 sessions	MSC 85/26, paragraph 23.45
L.1	Review of the implementation of STCW chapter VII <i>Strategic direction:</i> 5 <i>High-level action:</i> 5.2.2 <i>Planned output:</i> -	2 sessions	MSC 72/23, paragraph 21.56; STW 35/19, section 14
L.2	Clarification of the STCW-F Convention provisions and follow-up action to the associated Conference resolutions <i>Strategic direction:</i> 5 <i>High-level action:</i> 5.2.1 <i>Planned output:</i> -	2 sessions	STW 34/14, paragraph 11.8
L.3	Development of model procedures for executing shipboard emergency measures <i>Strategic direction:</i> 5 <i>High-level action:</i> 5.2.2 <i>Planned output:</i> 5.2.2.2	2 sessions	MSC 84/24, paragraph 22.67

* To be included in the provisional agenda for STW 41.

ANNEX 25**PROVISIONAL AGENDAS FOR THE FORTHCOMING SESSIONS
OF THE SUB-COMMITTEES****SUB-COMMITTEE ON BULK LIQUIDS AND GASES (BLG) – 13TH SESSION ***

- Opening of the session
- 1 Adoption of the agenda
 - 2 Decisions of other IMO bodies
 - 3 Evaluation of safety and pollution hazards of chemicals and preparation of consequential amendments
 - 4 Application of the requirements for the carriage of bio-fuels and bio-fuel blends
 - 5 Development of guidelines and other documents for uniform implementation of the 2004 BWM Convention
 - 6 Development of provisions for gas-fuelled ships
 - 7 Casualty analysis
 - 8 Consideration of IACS unified interpretations
 - 9 Development of international measures for minimizing the transfer of invasive aquatic species through bio-fouling of ships
 - 10 Review of the Recommendation for material safety data sheets for MARPOL Annex I cargoes and marine fuel oils
 - 11 Revision of the IGC Code
 - 12 Safety requirements for natural gas hydrate pellet carriers
 - 13 Review of relevant non-mandatory instruments as a consequence of the amended MARPOL Annex VI and the NO_x Technical Code
 - 14 Amendments to MARPOL Annex I on the use and carriage of heavy grade oil on ships in the Antarctic area
 - 15 Work programme and agenda for BLG 14
 - 16 Election of Chairman and Vice-Chairman for 2010
 - 17 Any other business
 - 18 Report to the Committees

* Agenda item numbers do not necessarily indicate priority.

**SUB-COMMITTEE ON DANGEROUS GOODS, SOLID CARGOES AND CONTAINERS (DSC) –
14TH SESSION***

- Opening of the session
- 1 Adoption of the agenda
 - 2 Decisions of other IMO bodies
 - 3 Amendments to the IMDG Code and supplements, including harmonization of the IMDG Code with the UN Recommendations on the transport of dangerous goods
 - .1 harmonization of the IMDG Code with the UN Recommendations on the transport of dangerous goods
 - .2 amendment (35-10) to the IMDG Code and supplements
 - 4 Amendments to the IMSBC Code, including evaluation of properties of solid bulk cargoes
 - 5 Amendments to the CSS Code and associated recommendations
 - 6 Casualty and incident reports and analysis
 - 7 Review of the BLU Code
 - 8 Review of the Recommendations on the safe use of pesticides in ships
 - 9 Guidance on protective clothing
 - 10 Revision of the Code of Safe Practice for Ships Carrying Timber Deck Cargoes
 - 11 Stowage of water-reactive materials
 - 12 Amendments to the International Convention for Safe Containers, 1972 and associated circulars
 - 13 Review of the Guidelines for packing of cargo transport units
 - 14 Review of documentation requirements for dangerous goods in packaged form
 - 15 Amendments to MARPOL Annex III**
 - 16 Revision of the Recommendations for entering enclosed spaces aboard ships

* Agenda item numbers do not necessarily indicate priority.

** Subject to the decision of MEPC 59.

- 17 Consideration for the efficacy of Container Inspection Programme
- 18 Work programme and agenda for DSC 15
- 19 Election of Chairman and Vice-Chairman for 2010
- 20 Any other business
- 21 Report to the Maritime Safety Committee

SUB-COMMITTEE ON FIRE PROTECTION (FP) – 53RD SESSION *

- Opening of the session
- 1 Adoption of the agenda
 - 2 Decisions of other IMO bodies
 - 3 Performance testing and approval standards for fire safety systems
 - 4 Comprehensive review of the Fire Test Procedures Code
 - 5 Measures to prevent explosions on oil and chemical tankers transporting low-flash point cargoes
 - 6 Fire resistance of ventilation ducts
 - 7 Guidelines for drainage systems in closed vehicle and ro-ro spaces and special category spaces
 - 8 Clarification of SOLAS chapter II-2 requirements regarding interrelation between central control station and safety centre
 - 9 Recommendation on evacuation analysis for new and existing passenger ships
 - 10 Measures to prevent fires in engine-rooms and cargo pump-rooms
 - 11 Development of provisions for gas-fuelled ships
 - 12 Consideration of IACS unified interpretations
 - 13 Fixed hydrocarbon gas detection systems on double-hull oil tankers
 - 14 Harmonization of the requirements for the location of entrances, air inlets and openings in the superstructures of tankers
 - 15 Amendments to SOLAS chapter II-2 related to the releasing controls and means of escape for spaces protected by fixed carbon dioxide systems
 - 16 Means of escape from machinery spaces
 - 17 Review of fire protection requirements for on-deck cargo areas
 - 18 Explanatory notes for the application of the safe return to port requirements
 - 19 Analysis of fire casualty records

* Agenda item numbers do not necessarily indicate priority.

- 20 Work programme and agenda for FP 54
- 21 Election of Chairman and Vice-Chairman for 2010
- 22 Any other business
- 23 Report to the Maritime Safety Committee

SUB-COMMITTEE ON FLAG STATE IMPLEMENTATION (FSI) – 17TH SESSION*

- Opening of the session
- 1 Adoption of the agenda
 - 2 Decisions of other IMO bodies
 - 3 Responsibilities of Governments and measures to encourage flag State compliance
 - 4 Mandatory reports under MARPOL
 - 5 Port reception facilities-related issues
 - 6 Casualty statistics and investigations
 - 7 Harmonization of port State control activities
 - 8 PSC guidelines on seafarers' working hours and PSC guidelines in relation to the Maritime Labour Convention, 2006
 - 9 Development of guidelines on port State control under the 2004 BWM Convention
 - 10 Comprehensive analysis of difficulties encountered in the implementation of IMO instruments
 - 11 Review of the Survey Guidelines under the HSSC
 - 12 Consideration of IACS unified interpretations
 - 13 Review of the Code for the Implementation of Mandatory IMO Instruments
 - 14 Development of a Code for Recognized Organizations
 - 15 Measures to protect the safety of persons rescued at sea
 - 16 Code of conduct during demonstrations/campaigns against ships on the high seas
 - 17 Work programme and agenda for FSI 18
 - 18 Election of Chairman and Vice-Chairman for 2010
 - 19 Any other business
 - 20 Report to the Committees

* Agenda item numbers do not necessarily indicate priority.

**SUB-COMMITTEE ON RADIOCOMMUNICATIONS AND SEARCH AND RESCUE (COMSAR) –
13TH SESSION***

- Opening of the session
- 1 Adoption of the agenda
- 2 Decisions of other IMO bodies
- 3 Global Maritime Distress and Safety System (GMDSS)
 - .1 matters relating to the GMDSS Master Plan
 - .2 operational and technical coordination provisions of maritime safety information (MSI) services, including review of the related documents
- 4 ITU maritime radiocommunication matters
 - .1 Radiocommunication ITU-R Study Group matters
 - .2 ITU World Radiocommunication Conference matters
- 5 Satellite services (Inmarsat and COSPAS-SARSAT)
- 6 Matters concerning search and rescue, including those related to the 1979 SAR Conference and the implementation of the GMDSS
 - .1 harmonization of aeronautical and maritime search and rescue procedures, including SAR training matters
 - .2 plan for the provision of maritime SAR services, including procedures for routing distress information in the GMDSS
- 7 Developments in maritime radiocommunication systems and technology
- 8 Revision of the IAMSAR Manual
- 9 Development of procedures for updating shipborne navigation and communication equipment
- 10 Measures to protect the safety of persons rescued at sea
- 11 Work programme and agenda for COMSAR 14
- 12 Election of Chairman and Vice-Chairman for 2010
- 13 Any other business
- 14 Report to the Maritime Safety Committee

* Agenda item numbers do not necessarily indicate priority.

SUB-COMMITTEE ON SAFETY OF NAVIGATION (NAV) – 55TH SESSION *

- Opening of the session
- 1 Adoption of the agenda
 - 2 Decisions of other IMO bodies
 - 3 Routeing of ships, ship reporting and related matters
 - 4 Development of guidelines for IBS, including performance standards for bridge alert management
 - 5 Guidelines for consideration of requests for safety zones larger than 500 metres around artificial islands, installations and structures in the EEZ
 - 6 Amendments to the Performance standards for VDR and S-VDR
 - 7 Development of procedures for updating shipborne navigation and communication equipment
 - 8 ITU matters, including Radiocommunication ITU-R Study Group matters
 - 9 Code of conduct during demonstrations/campaigns against ships on high seas
 - 10 Measures to minimize incorrect data transmissions by AIS equipment
 - 11 Development of an e-navigation strategy implementation plan
 - 12 Guidelines on the layout and ergonomic design of safety centres on passenger ships
 - 13 Review of vague expressions in SOLAS regulation V/22
 - 14 Revision of the Guidance on the application of AIS binary messages
 - 15 Improved safety of pilot transfer arrangements
 - 16 Casualty analysis
 - 17 Consideration of IACS unified interpretations
 - 18 Work programme and agenda for NAV 56
 - 19 Election of Chairman and Vice-Chairman for 2010
 - 20 Any other business
 - 21 Report to the Maritime Safety Committee

* Agenda item numbers do not necessarily indicate priority.

SUB-COMMITTEE ON SHIP DESIGN AND EQUIPMENT (DE) – 52ND SESSION *

- Opening of the session
- 1 Adoption of the agenda
 - 2 Decisions of other IMO bodies
 - 3 Amendments to resolution A.744(18)
 - 4 Revision of the Code on Alarms and Indicators
 - 5 Amendments to the MODU Code
 - 6 Measures to prevent accidents with lifeboats
 - 7 Compatibility of life-saving appliances
 - 8 Test standards for extended service intervals of inflatable liferafts
 - 9 Amendments to the Guidelines for ships operating in Arctic ice-covered waters
 - 10 Revision of resolution A.760(18)
 - 11 Guidelines for uniform operating limitations of high-speed craft
 - 12 Guidelines for maintenance and repair of protective coatings
 - 13 Performance standards for recovery systems
 - 14 Cargo oil tank coating and corrosion protection
 - 15 Guidance to ensure consistent policy for determining the need for watertight doors to remain open during navigation
 - 16 Development of a new framework of requirements for life-saving appliances
 - 17 Consideration of IACS unified interpretations
 - 18 Work programme and agenda for DE 53
 - 19 Election of Chairman and Vice-Chairman for 2010
 - 20 Any other business
 - 21 Report to the Maritime Safety Committee

* Agenda item numbers do not necessarily indicate priority.

**SUB-COMMITTEE ON STABILITY AND LOAD LINES AND ON FISHING VESSELS SAFETY (SLF) –
52ND SESSION***

- Opening of the session and election of Chairman and Vice-Chairman for 2010
- 1 Adoption of the agenda
 - 2 Decisions of other IMO bodies
 - 3 Development of new generation intact stability criteria
 - 4 Safety of small fishing vessels
 - 5 Development of options to improve effect on ship design and safety of the 1969 TM Convention
 - 6 Time-dependent survivability of passenger ships in damaged condition
 - 7 Guidance on the impact of open watertight doors on existing and new ship survivability
 - 8 Stability and sea-keeping characteristics of damaged passenger ships in a seaway when returning to port by own power or under tow
 - 9 Guidelines for verification of damage stability requirements for tankers and bulk carriers
 - 10 Safety provisions applicable to tenders operating from passenger ships
 - 11 Damage stability regulations for ro-ro passenger ships
 - 12 Development of an agreement on the implementation of the 1993 Torremolinos Protocol
 - 13 Consideration of IACS unified interpretations
 - 14 Subdivision standards for cargo ships
 - 15 Work programme and agenda for SLF 53
 - 16 Election of Chairman and Vice-Chairman for 2011
 - 17 Any other business
 - 18 Report to the Maritime Safety Committee

* Agenda item numbers do not necessarily indicate priority.

SUB-COMMITTEE ON STANDARDS OF TRAINING AND WATCHKEEPING (STW) – 40TH SESSION*

- Opening of the session
- 1 Adoption of the agenda
 - 2 Decisions of other IMO bodies
 - 3 Validation of model training courses
 - 4 Unlawful practices associated with certificates of competency
 - 5 Training for seafarer safety representatives
 - 6 Casualty analysis
 - 7 Comprehensive review of the STCW Convention and Code:
 - .1 chapter I of the STCW Convention and Code
 - .2 chapter II of the STCW Convention and Code
 - .3 chapter III of the STCW Convention and Code
 - .4 chapter IV of the STCW Convention and Code
 - .5 chapter V of the STCW Convention and Code
 - .6 chapter VI of the STCW Convention and Code
 - .7 chapter VII of the STCW Convention and Code
 - .8 chapter VIII of the STCW Convention and Code
 - 8 Review of the principles for establishing the safe manning level of ships
 - 9 Measures to enhance maritime security
 - 10 Mandatory requirements for determining safe manning
 - 11 Work programme and agenda for STW 41
 - 12 Election of Chairman and Vice-Chairman for 2010
 - 13 Any other business
 - 14 Report to the Maritime Safety Committee

* Agenda item numbers do not necessarily indicate priority.

ANNEX 26

STATEMENT BY THE DELEGATION OF HONG KONG, CHINA

Mr. Chairman,

Hong Kong, China deeply regrets that the Master and Chief Officer of the Hong Kong, China-registered vessel **Hebei Spirit** are still prevented from leaving the Republic of Korea nearly a year after the incident. Such a measure is obviously not in line with the IMO/ILO Guidelines on fair treatment of seafarers in the event of a maritime accident.

We understand that the legal proceedings are still going on in the Republic of Korea and respect the Court of the Republic of Korea would in due course hand down its judgment on the part played by the vessel **Hebei Spirit** in this serious pollution accident. However, as ruled by the Court of the First Instance, there is no evidence whatsoever to suggest that the two officers had acted in any way that might be construed as a wilful act that would have caused the accident. The continued detention of the two officers in the Republic of Korea is obviously unjustified and amounts to a blatant disregard of the human rights these two men are entitled to have.

We wish to draw the attention of the Republic of Korea to Article 230(2) of UNCLOS, which states that even if a vessel is ruled partially responsible for the pollution incident due to violation of national laws or applicable international rules or standards, only monetary penalties may be imposed. This delegation therefore urges the Authorities of the Republic of Korea, as a contracting party to UNCLOS, to adhere to the provisions of the Convention in handling the **Hebei Spirit** incident.

Thank you, Mr. Chairman.

ANNEX 27**STATEMENTS BY THE DELEGATION OF TURKEY****OBSERVATIONS OF TURKEY FOR THE FUTURE IMPLEMENTATION AND POSSIBLE
ADAPTATION OF THE LRIT SYSTEM**

As the members of the Group may recall, we informed the Committee last Friday of our national preparations for the timely implementation of the LRIT System. For the sake of brevity, I will not repeat them here but just want to briefly highlight that Turkey's National LRIT Data Centre and Application Service Provider have already been established. Our ASP will also be available to serve as a nodal DC for other interested countries. We are now at the initial testing phase of our national system.

At the Committee meeting, we also expressed our intention to share some of our observations with the *Ad Hoc* Group in light of the outcome of the preparations and initial testing of our national system. These observations are as follows:

Firstly, the polygons suggested for the purpose of long-range identification and tracking of vessels should meet the needs of all coastal states, flag states and maritime administrations. These polygons in reality can only represent the service areas where LRIT system elements are expected to function with a view to serving the needs of different contracting governments and agencies in terms of identifying and tracking maritime traffic.

Secondly, the specific characteristics of different geographical features, including in particular those related to sea areas, as well as available means of communication and other relevant circumstances must be taken into account before and during the full implementation phase. This is particularly important in semi-enclosed and enclosed seas. In fact, the situation of coastal countries with an opening towards a vast ocean and those situated around enclosed/semi-enclosed seas cannot be comparable.

Thirdly, the requirements of a coastal state for the identification and tracking of maritime traffic in the vicinity of its landmass beyond territorial waters should be considered as reasonable and legitimate, particularly if such a country is situated in an enclosed/semi-enclosed sea area.

In this context, the immediate vicinity of a coastal state should be admitted as a security zone where all maritime traffic will have to be monitored exclusively, the near vicinity where coastal states have responsibilities for certain activities such as search and rescue, protection of marine environment, should be seen as a safety zone, the range within which maritime traffic could be followed for customs or similar purposes should be considered as a tracking zone, and finally the maximum limit (up to 1,000 nm) for the recognition of vessels of interest should be regarded as an identification zone. These definitions are illustrative and thus can be adjusted or developed further as appropriate.

Obviously, as stated and agreed in principle at MSC 84 and reiterated subsequently during various WG meetings, LRIT polygons, their limits and any terminology used to define them are without prejudice to any legal and political position of the countries concerned and will not have any bearing on them in accordance with international law. However, using the above-mentioned definitions in lieu of the existing terminology to define LRIT polygons will not

only serve the purpose, but will at the same time prevent any misunderstandings that might emerge as a result of possible overlapping maritime zones.

We believe that these observations could assist the LRIT WG in recommending further adaptations to the MSC for a seamless functioning of the system in line with the practical requirements of the user nations.

Turkey will further follow up this matter at the next session of the Committee and the forthcoming meetings of the *Ad Hoc* WG.

At this stage, we would like to request the LRIT WG and the Committee to note these observations and reflect them into their reports accordingly.

STATEMENT OF TURKEY IN RESPONSE TO THAT OF THE GREEK DELEGATION

Thank you Mr. Chairman,

After the statement of distinguished delegation of Greece, I feel obliged to clarify our views and observations that we shared with the LRIT WG yesterday.

Mr. Chairman,

First of all, I would like to underline that Turkey is fully committed to the timely establishment and the effective implementation of the LRIT system.

With this understanding, our delegation, at this session of the MSC, tried to draw the attention of the membership to potential problems which might arise, as a result of the terminology, being used for the identification of the LRIT polygons.

That is to say, if the geographical information provided by the contracting parties, for technical purposes of the LRIT system is regarded as representing maritime jurisdiction areas, this might lead to problems entailing maritime jurisdiction issues, during the implementation of the LRIT system and would eventually impede its effective functioning.

One way to overcome this potential problem, without necessarily having to amend the SOLAS, could be the adaptation of the LRIT system through the possible use of illustrative definitions, in lieu of the existing terminology to define LRIT polygons.

In good faith and with the spirit of cooperation, we offered this thought as part of our observations that we shared in detail with the LRIT Working Group yesterday.

Unfortunately, the statement of the distinguished representative of Greece, which we cannot agree, fails to capture the very premise of our observations as well as our constructive approach.

At this point in time, we only expect the IMO membership to note these observations so that they can be examined thoroughly and be given due consideration in our future work. As we mentioned yesterday Turkey will further follow up this matter at the next session of the Committee and the forthcoming meetings of the *Ad Hoc* WG.

ANNEX 28**STATEMENT BY THE DELEGATION OF GREECE**

Referring to the observations made by the Turkish delegation on the future implementation and possible adaptation of the LRIT System, the Greek delegation would like to make the following comments.

The Turkish views are not compatible either with the agreed framework of the LRIT System or the applicable rules of international law of the sea. More specifically, the proposed new terminology, namely “security zone”, “safety zone”, “tracking zone” and “identification zone” would appear to disregard the existing jurisdictional framework of the law of the sea and may lead to confusion as to the respective rights of coastal states.

It has to be recalled that, in the Caveat agreed by the Contracting States to be posted on the LRIT Data Distribution Plan (MSC.1/Circ.1256, annex, Appendix, page 11), it is specifically stated that “none of the data or information provided in relation to the geographical areas defined in the LRIT Data Distribution Plan shall prejudice the rights, jurisdiction or obligations of States under international law, in particular relating to, the continental shelf, the legal regimes of the high seas, the exclusive economic zone, the contiguous zone, the territorial seas, internal waters or the straits used for international navigation and archipelagic sea lanes”.

In our view, this covers the concerns of the Turkish delegation.

Furthermore, Greece would like to underline that the LRIT system is not related to the concept of semi-enclosed seas; this concept, which was introduced by Article 122 of the UN Convention on the Law of the Sea, concerns exclusively the issues provided for in Article 123 of the Convention.

In light of the above, we believe that the established terminology to define the LRIT System and polygons is both satisfactory and compatible with the international law of the sea. Thus, there is no added value for further discussion of the aforementioned Turkish views either within the next session of the Committee or the forthcoming meetings of the *Ad Hoc* WG.

We thank the delegations for their attention and we would like these observations to be included in the final report of the Committee.
